

Exact and Intuitive Geometry Explanation: Why Does a Half-angle-rotation in Spin or Quaternion Space Correspond to the Whole-angle-rotation in Normal 3D Space?

Hongbing Zhang

October 2018

Abstract

Why does a half-angle-rotation in quaternion space or 1/2 spin space correspond to a whole-angle-rotation in normal 3D space? The question is equivalent to why a half angle in the representation of SU_2 corresponds to a whole angle in the representation of SO_3 . Usually we use the computation of the abstract mathematics to answer the question. But now I will give an exact and intuitive geometry-explanation on it in this paper.

1. Rotation of a vector or the coordinate-system in a plane

It is very intuitive to represent the rotation of a vector in a plane, the 2-D space. We can chose the complex plane or the real plane. For simplicity, the length of the vector can be take 1 unit. The position-vector rotates around O point.

In a complex plane, the vector can be represented by a complex number C:

$$C = e^{i\alpha} = \cos \alpha + i \sin \alpha$$

Here is the Eulers formula. $i^2 = -1$. (Generally, by Taylor expansion, if $A^2 = -1$, we can get: $e^{A\alpha} = \cos \alpha + A \sin \alpha$.)

And its rotation by an angle θ can be represented by:

$$e^{i\theta}C = e^{i\theta}e^{i\alpha} = e^{i(\alpha+\theta)}.$$

Here, the i is the imaginary unit, its geometric significance is to rotate the vector (in the complex plane) by $\pi/2$ anti-clockwise.

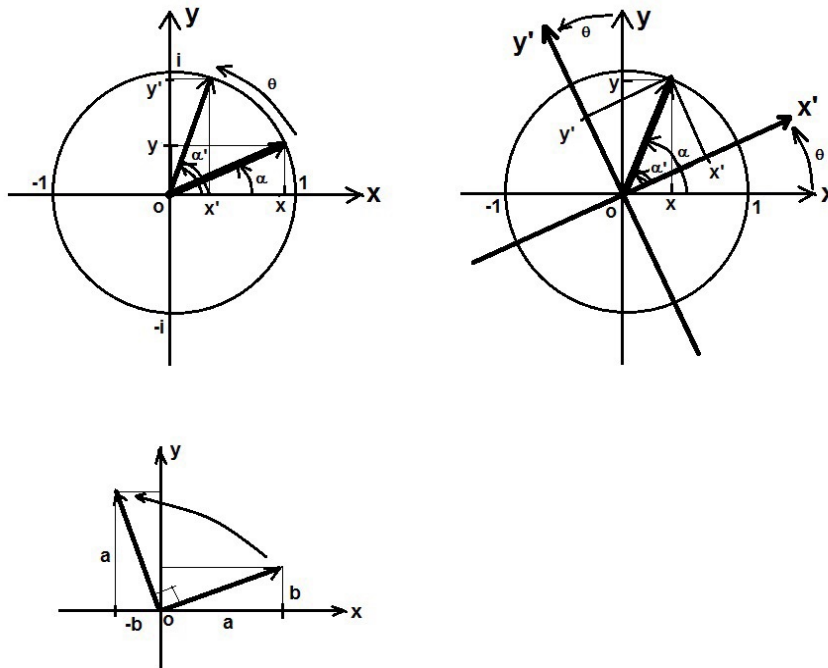

Figure 1

We can also describe these in a real plane. Denote the vector by an ordered pair of real number as:

$$\mathbf{V} = \begin{pmatrix} a \\ b \end{pmatrix}$$

when it rotate by $\pi/2$ anti-clockwise, it changes to the vector:

$$\mathbf{V}' = \begin{pmatrix} -b \\ a \end{pmatrix}$$

So, the rotation can be represented with:

$$\begin{pmatrix} 0 & -1 \\ 1 & 0 \end{pmatrix} \begin{pmatrix} a \\ b \end{pmatrix} = \begin{pmatrix} -b \\ a \end{pmatrix}$$

so,

$$i \sim \begin{pmatrix} 0 & -1 \\ 1 & 0 \end{pmatrix}$$

The representation of the rotation by θ is:

$$e^{i\theta} = \cos \theta + i \sin \theta \sim$$

$$\begin{pmatrix} 1 & 0 \\ 0 & 1 \end{pmatrix} \cos \theta + \begin{pmatrix} 0 & -1 \\ 1 & 0 \end{pmatrix} \sin \theta = \begin{pmatrix} \cos \theta & -\sin \theta \\ \sin \theta & \cos \theta \end{pmatrix}$$

This is the correspondence of U_1 with SO_2 . Notice that the determination of the 2×2 matrix above is one, that is why we say SO_2 , the S means special.

Because of the relativity of motion, a rotation of the coordinate-system by θ angle (with the vector fixed), is equivalent to the rotation of the vector by $-\theta$ (with the coordinate-system fixed). Thus, when coordinate-system rotate by θ , the vector will change as:

$$\begin{pmatrix} \cos(-\theta) & -\sin(-\theta) \\ \sin(-\theta) & \cos(-\theta) \end{pmatrix} \begin{pmatrix} a \\ b \end{pmatrix} = \begin{pmatrix} \cos \theta & \sin \theta \\ -\sin \theta & \cos \theta \end{pmatrix} \begin{pmatrix} a \\ b \end{pmatrix} = \begin{pmatrix} a' \\ b' \end{pmatrix}$$

Notice that the rotation in a plane has only one parameter.

Generally, when we want to rotate a vector to another, we can always put a reference-frame at the right position so that one of its axis covers the target vector. From this view, all points on the unit circle are mapping to all operators of rotations in the plane.

2. How to describe a 3D vector in a 2D plane

A 3D vector has three parameters, $x, y,$ and z in Descartes' coordinate system. But the rotation has two parameters, because rotation must preserve the length of the vector.

$$x'^2 + y'^2 + z'^2 = x^2 + y^2 + z^2 = 1.$$

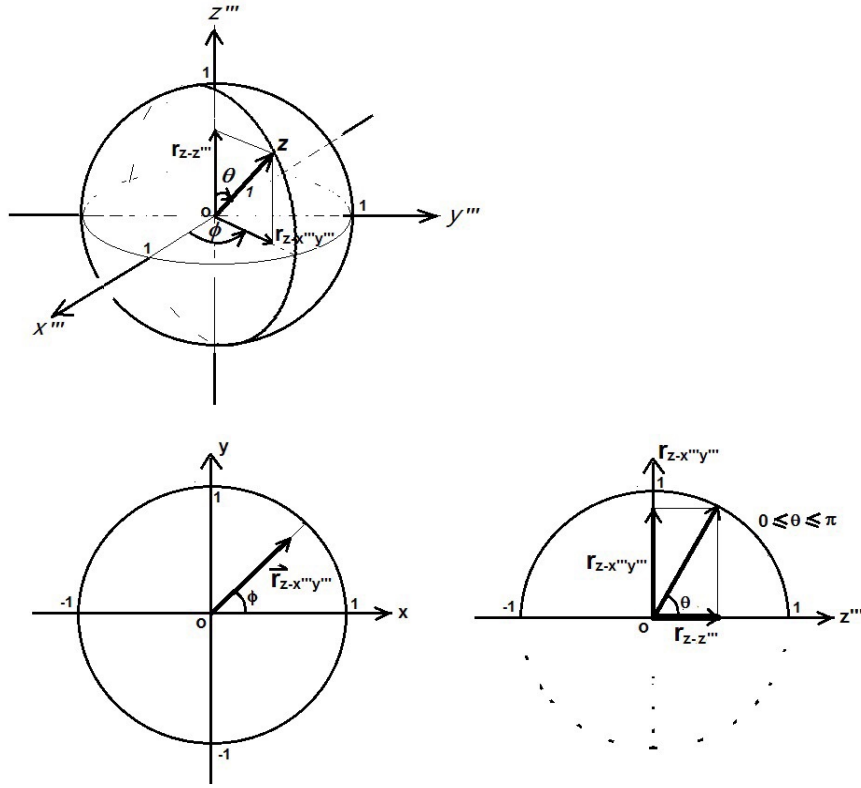

Figure 2

(We rotate the unite length vectors.)

Consider the Z unit axis in the $X'''Y'''Z'''$ reference-frame, its rotation can form a sphere. In $X'''Y'''Z'''$ coordinate-system, a specified and fixed unit axis Z , has two parameters of angle, The azimuth angle ϕ and the polar angle θ , as in Figure 2.

The unite axis Z , can have two projections, one is to the Z''' axis, can be denoted as $r_{z \rightarrow z'''}$, another is to the $X'''Y'''$ plane, denoted as $r_{z \rightarrow x''',y'''}$. They are determined by the polo angle θ ,

$$r_{z \rightarrow z'''} = \cos \theta, \quad r_{z \rightarrow x''',y'''} = \sin \theta$$

Notice: The domain of the θ angle is within π . (We consider the least positive period).

$r_{z \rightarrow x''',y'''}$ is always positive or zero,

$$0 \leq r_{z \rightarrow x''',y'''} \leq 1.$$

but, $r_{z \rightarrow z'''}$ may be positive or negative, or zero.

$$-1 \leq r_{z \rightarrow z'''} \leq +1.$$

Now we give the $r_{z \rightarrow z'''}$ and $r_{z \rightarrow x''''y''''}$ a common phase, make them to become two complex numbers:

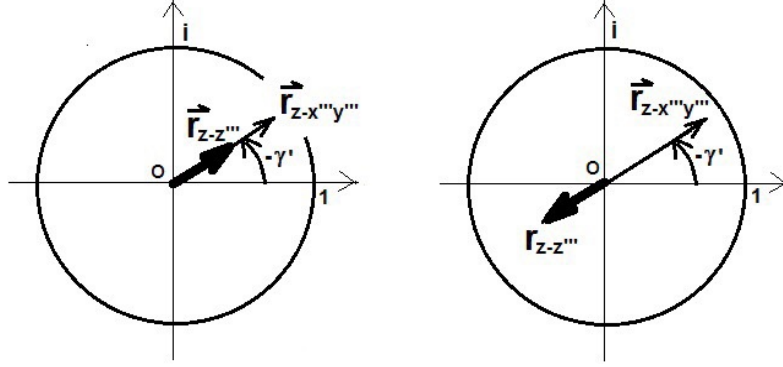

Figure 3

$$r_{z \rightarrow z'''} \rightarrow C'_1 = r_{z \rightarrow z'''} e^{-i\gamma'}, \quad r_{z \rightarrow x''''y''''} \rightarrow C'_2 = r_{z \rightarrow x''''y''''} e^{-i\gamma'}.$$

We denote them as an ordered pair:

$$\begin{pmatrix} C'_1 \\ C'_2 \end{pmatrix} = \begin{pmatrix} r_{z \rightarrow z'''} e^{-i\gamma'} \\ r_{z \rightarrow x''''y''''} e^{-i\gamma'} \end{pmatrix},$$

here

$$\begin{aligned} -1 &\leq r_{z \rightarrow z'''} \leq 1, \\ 0 &\leq r_{z \rightarrow x''''y''''} \leq 1, \\ r_{z \rightarrow z'''}^2 + r_{z \rightarrow x''''y''''}^2 &= 1. \end{aligned}$$

Temporarily, the phase $-\gamma'$ is arbitrary, later we can see its significance.

Now we draw them together in a same one complex plane, by the rule:

When $r_{z \rightarrow z'''} is positive, we draw C'_1 to the same direction with C'_2 , when $r_{z \rightarrow z'''} is negative, we draw C'_1 to the opposite direction with C'_2 .$$

Does it surely mean that the two vectors in the complex plane must always have the same phase angle? No. That's the key problem we will discuss later.

3. Rotation of a 3D Rigid Body

3D vector has three parameters, as x, y and z . Its rotation has at least two parameters, as ϕ and θ . But, the rotation of 3D rigid body has three parameters, because it can have a rotation about the vector Z itself in the reference-frame $X''''Y''''Z''''$. The vector Z can be regarded as one of the axes of another reference-frame XYZ . A 3D reference-frame can be regarded as a 3D rigid body. Now the X and Y axes can also rotate about Z . As in Figure 4.

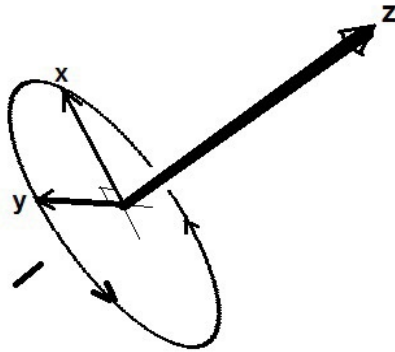

Figure 4

And of course, The XYZ frame can also rotate about the Y axis or X axis. We will consider them successively.

Now we want to rotate the XYZ -frame to the target state: the $X''''Y''''Z''''$ -frame.

Let us suppose that there are two similar books, one is motionless, another one is at an arbitrary angle state and it will rotate to coincide right on the motionless book. Assume X is along the longest edge of the book, Y is along the middle-length-edge, and Z along the shortest edge.

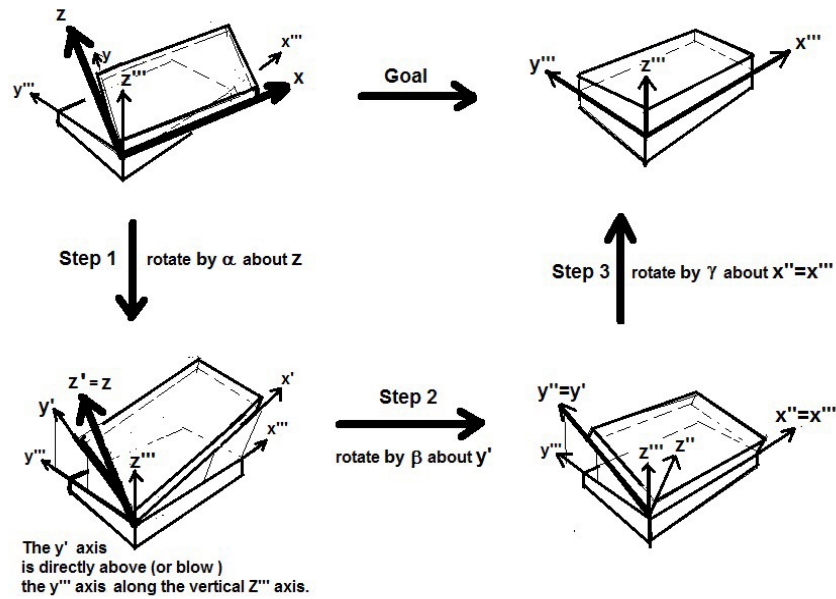

Figure 5

As in Figure 5, we can finish the operation with three steps:

Step 1) rotate by α about Z .

Then the XYZ -system becomes $X'Y'Z'$ -system.

Notice: when the step 1 is finished, the Y' axis will have been exactly and directly above (or right below, or coincidence to) the Y''' axis along the vertical Z axis direction.

Step 2) rotate by β about Y' .

Then the $X'Y'Z'$ -system becomes $X''Y''Z''$ -system.

Notice: when the step 2 is finished, the X'' will have been completely coincide with the X''' .

step 3) rotate by γ angle about X'' axis.

Then the two coordinate-systems will completely coincide. That is the target state. (In the Figure , the γ is negative).

The α , β and γ are called the Eulers angles.

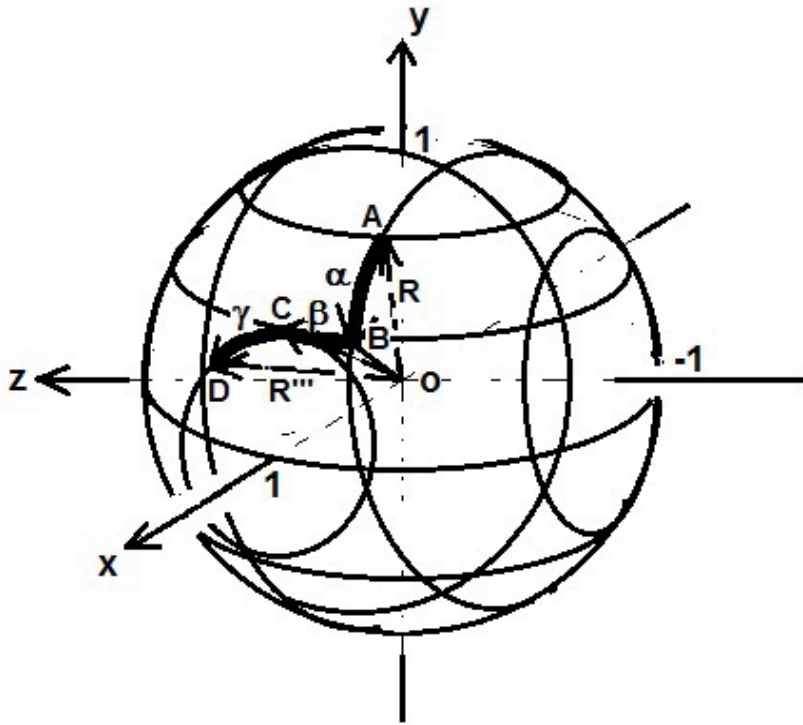

Figure 6

Figure 6 demonstrate the other perspective that the vector rotates but the coordinate-system is fixed. Its equivalent to the view that the vector is motionless but the coordinate-system rotates. We need only to take the opposite directions of the angles.

On the other view, the vector is originally at the A position,

$$V = \begin{pmatrix} x \\ y \\ z \end{pmatrix}$$

Its target is going to the D position. There are also three steps to realize the target. In step 1, it rotates by α about Z axis, then it comes to the B position,

$$V' = \begin{pmatrix} x' \\ y' \\ z' \end{pmatrix}$$

then followed by step 2, the vector rotates by β about Y axis, comes to the C position, then followed by step 3, it rotates by γ about X axis, finally arrives at the D position.

In order to be simple, we can presume that the D position is (although it is not in the Figure):

$$\begin{pmatrix} 0 \\ 1 \\ 0 \end{pmatrix}$$

we can always set the coordinate-system to fit this requirement. Representations of the 3 steps are:

1)

$$R_z V = \begin{pmatrix} \cos \alpha & \sin \alpha & 0 \\ -\sin \alpha & \cos \alpha & 0 \\ 0 & 0 & 1 \end{pmatrix} \begin{pmatrix} x \\ y \\ z \end{pmatrix} = \begin{pmatrix} x' \\ y' \\ z' \end{pmatrix},$$

$$R_y V = \begin{pmatrix} \cos \beta & 0 & -\sin \beta \\ 0 & 1 & 0 \\ \sin \beta & 0 & \cos \beta \end{pmatrix} \begin{pmatrix} x' \\ y' \\ z' \end{pmatrix} = \begin{pmatrix} x'' \\ y'' \\ z'' \end{pmatrix},$$

$$R_x = \begin{pmatrix} 1 & 0 & 0 \\ 0 & \cos \gamma & \sin \gamma \\ 0 & -\sin \gamma & \cos \gamma \end{pmatrix} \begin{pmatrix} x'' \\ y'' \\ z'' \end{pmatrix} = \begin{pmatrix} x''' \\ y''' \\ z''' \end{pmatrix}$$

And we can write simply:

$$\begin{aligned} R_z &= \begin{pmatrix} \cos \alpha & \sin \alpha & 0 \\ -\sin \alpha & \cos \alpha & 0 \\ 0 & 0 & 1 \end{pmatrix} = \begin{pmatrix} 1 & 0 & 0 \\ 0 & 1 & 0 \\ 0 & 0 & 1 \end{pmatrix} \cos \alpha + i \begin{pmatrix} 0 & -i & 0 \\ i & 0 & 0 \\ 0 & 0 & 0 \end{pmatrix} \sin \alpha \\ &= \cos \alpha + i J_z \sin \alpha = e^{i J_z \alpha}, \end{aligned}$$

because the matrix $(i J_z)^2 = -1$.

In the same way, we can get:

$$R_y = e^{i J_y \beta}, \quad R_x = e^{i J_x \gamma}.$$

The R_z , R_y and R_x belong to SO_3 , and the J_z , J_y and J_x are their generators.

4. Describe the Rotations of 3D Rigid Body in a Complex Plane

Now, we consider how to describe the rotations of 3D rigid body in a complex plane. Let us recall how the vector Z in $X'''Y'''Z'''$ was represented in a plane.

We have drawn the two projections of unit Z axis, $r_{z \rightarrow z''}$ and $r_{z \rightarrow x'''y''}$, in a complex plane as the form of an ordered pair:

$$\begin{pmatrix} C'_1 \\ C'_2 \end{pmatrix} = \begin{pmatrix} r_{z \rightarrow z''} e^{-i\gamma} \\ r_{z \rightarrow x'''y''} e^{-i\gamma} \end{pmatrix}$$

When $r_{z \rightarrow z''} \geq 0$, the phase of C'_1 is $-\gamma'$, when $r_{z \rightarrow z''} \leq 0$, the phase of C'_1 is $-\gamma' + \pi$.

Now let us rotate C'_1 (change its phase) to correspond to rotate the XYZ -frame about Z axis in 3D space. As in Figure 7.

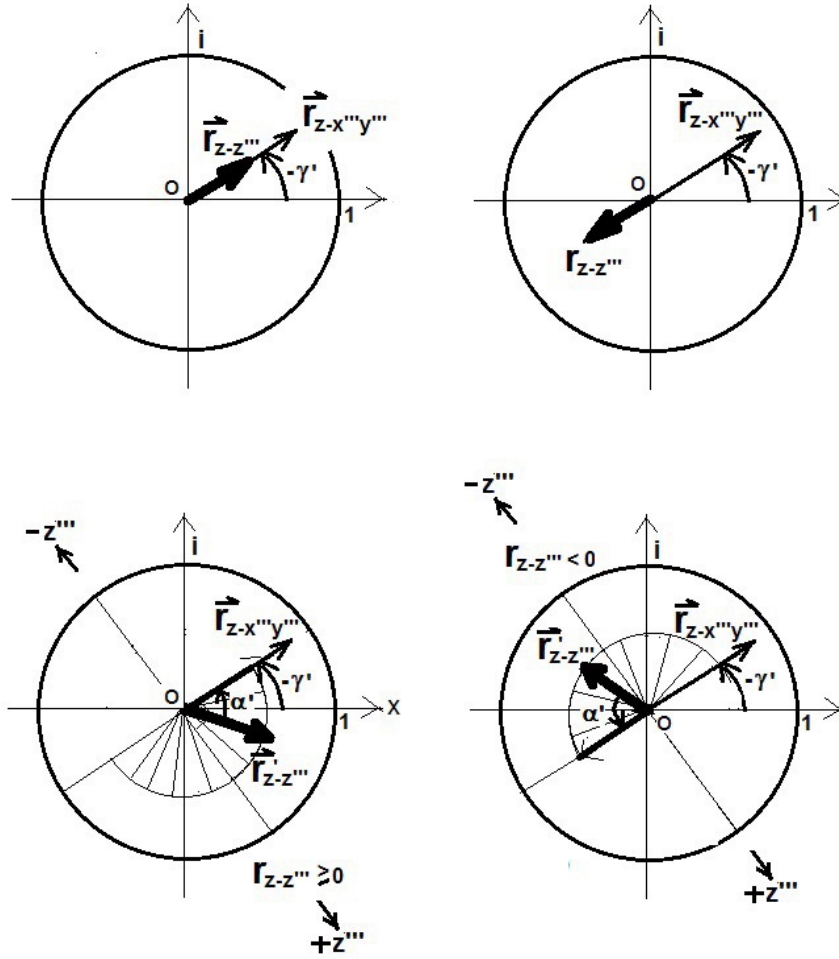

Figure 7

The key problem comes out now. When we rotate XYZ -frame about Z axis in 3D space, that means the Z axis is fixed, so $r_{z \rightarrow z''''}$ is fixed, either positive or negative.

When $r_{z \rightarrow z''''}$ is positive, the domain of the phase-changing of C'_1 is π , not 2π , because another π domain is belongs to negative $r_{z \rightarrow z''''}$. We must distinguish the positive and negative $r_{z \rightarrow z''''}$.

But, the domain of changing-angle of rotation about Z axis in 3D space is 2π . Thus, we must take:

$$\alpha' = \alpha/2,$$

in order to establish the map between the two rotations in different space, one is in a 3D space, another is in a complex plane.

C'_1 can be C_1 at first, when C_1 rotates by $\alpha/2$ phase angle, it will change to C'_1 , and

$$\begin{pmatrix} C'_1 \\ C'_2 \end{pmatrix}$$

corresponds to this state in 3D: Y' axis is exactly directly above or right below Y''' axis, as the result of step 1 in 3D rotation of XYZ -frame.

The representation is:

$$\begin{pmatrix} e^{i\alpha/2} & 0 \\ 0 & 1 \end{pmatrix} \begin{pmatrix} C_1 \\ C_2 \end{pmatrix} = \begin{pmatrix} C'_1 \\ C'_2 \end{pmatrix} = \begin{pmatrix} r_{z \rightarrow z'''} e^{-i\gamma'} \\ r_{z \rightarrow x'''} y''' e^{-i\gamma'} \end{pmatrix}$$

but the determinate of the matrix on the left is not 1, although it belongs to the representations of U_2 , but not belongs to SU_2 . In order to obtain the matrix which belongs to the representations of SU_2 , we can presume there is a C_2 , it will rotate by $-\alpha/2$ to C'_2 .

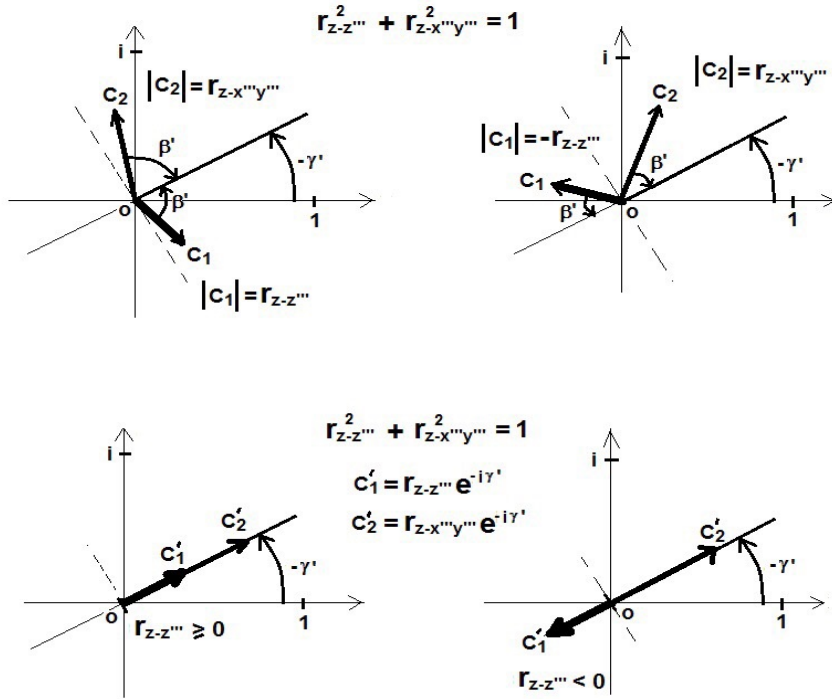

Figure 8

$$\begin{pmatrix} e^{i\alpha/2} & 0 \\ 0 & e^{-i\alpha/2} \end{pmatrix} \begin{pmatrix} C_1 \\ C_2 \end{pmatrix} = \begin{pmatrix} C'_1 \\ C'_2 \end{pmatrix} = \begin{pmatrix} r_{z \rightarrow z'''} e^{-i\gamma'} \\ r_{z \rightarrow x'''} y'''' e^{-i\gamma'} \end{pmatrix}$$

This operation does not have any influence on the judgment of whether $r_{z \rightarrow z'''}$ is positive or negative, because the bisector of the angle between C_1 and C_2 can act the role helping for the judgment.

The phase of the bisector of the angle between C_1 and C_2 (or its perpendicular line, when the $r_{z \rightarrow z'''}$ is negative) is always invariable $-\gamma'$. As Figure 8.

5. Adjust the relative modulus-lengths of the C'_1 and C'_2 to correspond to the 3D rotation about Y'

Then let us go back to see the polar angle θ .

Its role is to assign the relative lengths between $r_{z \rightarrow z'''}$ and $r_{z \rightarrow x'''} y''''$. As in Figure 9.

$$\begin{aligned} (r_{z \rightarrow z'''})^2 + (r_{z \rightarrow x'''} y'''')^2 &= 1, \\ r_{z \rightarrow z'''} &= \cos \theta, \quad r_{z \rightarrow x'''} y'''' = \sin \theta. \\ 0 &\leq \theta \leq \pi. \end{aligned}$$

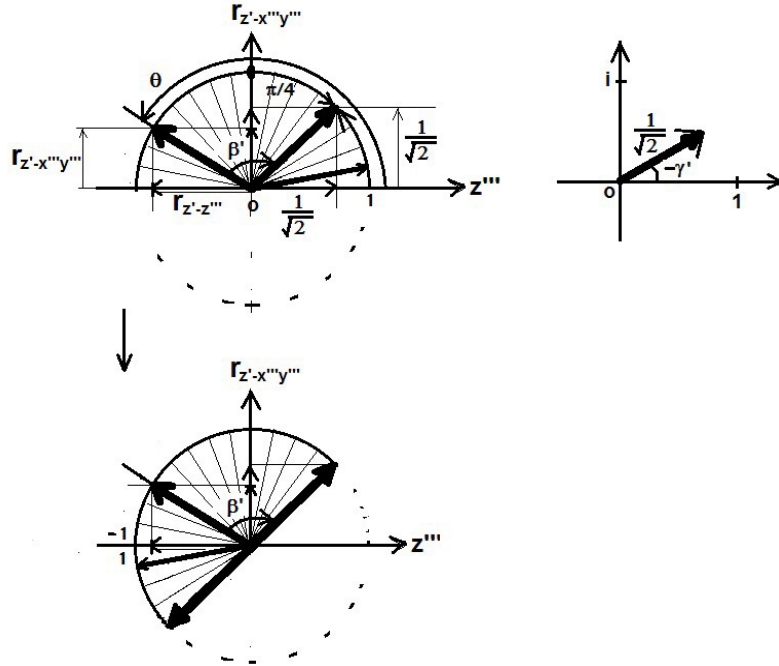

Figure 9

Now we presume that when

$$r_{z \rightarrow z'''} = r_{z \rightarrow x''y'''} = \frac{1}{\sqrt{2}},$$

in other words, their related complex numbers are same completely : $C''_1 = C''_2$, this state in the complex plane, corresponds to the target-state of step 2 of rotation of the 3D rigid body: the X'' axis coincides with the X''' in the 3D space. In the complex plane, here is a corresponding representation to realize this state:

$$\begin{aligned} \begin{pmatrix} \cos \beta' & \sin \beta' \\ -\sin \beta' & \cos \beta' \end{pmatrix} \begin{pmatrix} C''_1 \\ C''_2 \end{pmatrix} &= \begin{pmatrix} \cos \beta' & \sin \beta' \\ -\sin \beta' & \cos \beta' \end{pmatrix} \begin{pmatrix} r_{z \rightarrow z'''} \\ r_{z \rightarrow x''y'''} \end{pmatrix} e^{-i\gamma'} \\ &= \begin{pmatrix} 1/\sqrt{2} \\ 1/\sqrt{2} \end{pmatrix} e^{-i\gamma'} = \begin{pmatrix} C''_1 \\ C''_2 \end{pmatrix} \end{aligned}$$

Notice that the domain of β' is within π , as Figure 9, but the domain of the angle β by which the 3D coordination-system $X'Y'Z'$ rotates about Y' axis is 2π , so we must take:

$$\beta' = \beta/2,$$

in order to establish the corresponding relationship between the two rotations, one is in 3D space, another is in a complex plane.

6. Rotation about X

We have already obtained the two matrices in the complex plane to represent the 3D rotations about Z axis and about Y' successively. They are:

$$\begin{aligned} S_z &= \begin{pmatrix} e^{i\alpha/2} & 0 \\ 0 & e^{-i\alpha/2} \end{pmatrix} \\ S_y &= \begin{pmatrix} \cos \frac{\beta}{2} & \sin \frac{\beta}{2} \\ -\sin \frac{\beta}{2} & \cos \frac{\beta}{2} \end{pmatrix} \end{aligned}$$

Now, we can use the two matrices of rotations to derive the third matrix representing the 3D rotation about X'' axis. The method comes from the Feynmans Lecture on Physics, Book 3:

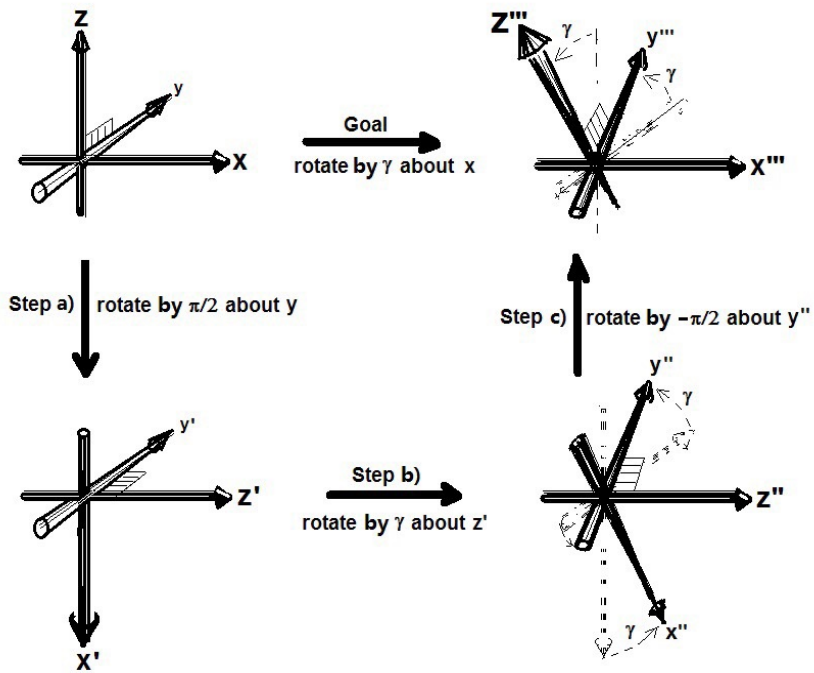

Figure 10

A rotation by γ about the X'' axis, is equivalent to:

- a) a rotation by $+\pi/2$ about Y , followed by
- b) a rotate by γ about Z' , followed by
- c) a rotation by $-\pi/2$ about Y'' .

Figure 10 and Figure 11 relatively demonstrate the subjective and the objective views.

So we have:

$$S_x = \begin{pmatrix} \cos(-\pi/4) & \sin(-\pi/4) \\ -\sin(-\pi/4) & \cos(-\pi/4) \end{pmatrix} \begin{pmatrix} e^{i\gamma} & 0 \\ 0 & e^{-i\gamma} \end{pmatrix} \begin{pmatrix} \cos(\pi/4) & \sin(\pi/4) \\ -\sin(\pi/4) & \cos(\pi/4) \end{pmatrix}$$

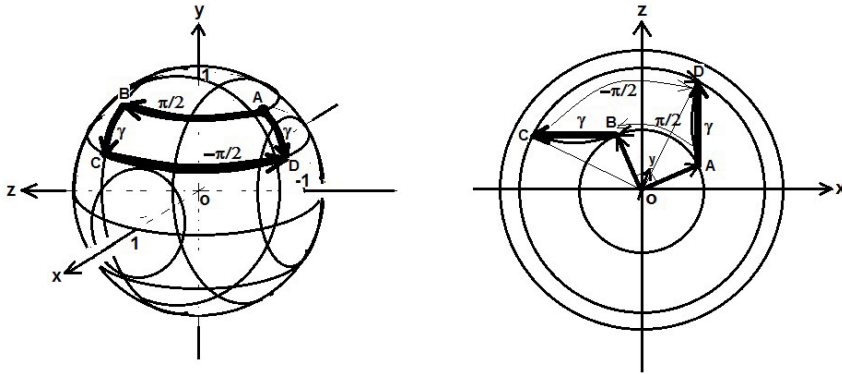

Figure 11

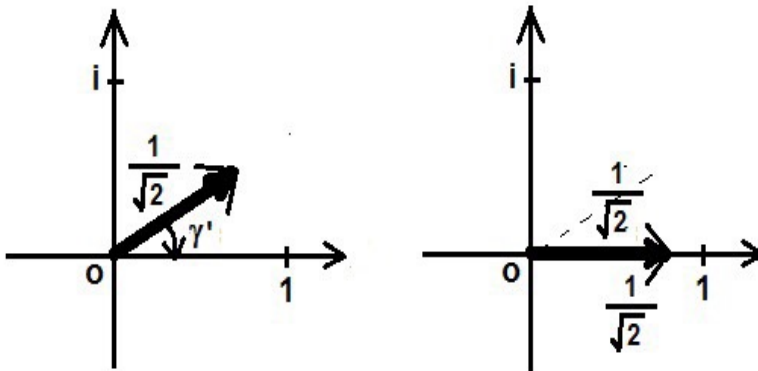

Figure 12

$$= \begin{pmatrix} \cos(\gamma/2) & i \sin(\gamma/2) \\ i \sin(\gamma/2) & \cos(\gamma/2) \end{pmatrix}$$

We have used the Euler's formula:

$$\cos \psi = \frac{e^{i\psi} + e^{-i\psi}}{2},$$

$$\sin \psi = \frac{e^{i\psi} - e^{-i\psi}}{2i}.$$

Notice that the determinate of the S_x is 1.

Let us go back to look at the Figure 12, if we take $\gamma' = \gamma/2$ in it, we get:

$$\begin{aligned} S_x \begin{pmatrix} C''_1 \\ C''_2 \end{pmatrix} &= \begin{pmatrix} \cos(\gamma/2) & i \sin(\gamma/2) \\ i \sin(\gamma/2) & \cos(\gamma/2) \end{pmatrix} \begin{pmatrix} 1/\sqrt{2} \\ 1/\sqrt{2} \end{pmatrix} e^{-i\gamma'} \\ &= \begin{pmatrix} 1/\sqrt{2} \\ 1/\sqrt{2} \end{pmatrix} = \begin{pmatrix} C'''_1 \\ C'''_2 \end{pmatrix} \end{aligned}$$

The result corresponds to the final state of 3D rotation: the two coordinates are coincided (in other words, the 3D rigid body had finished its 3D rotation).

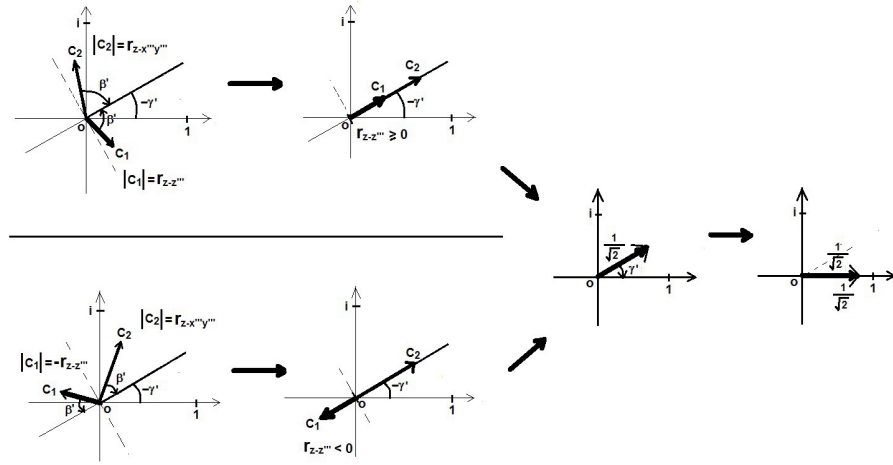

Figure 13

In Figure 13, we review the whole 3 steps in a plane which correspond the 3 steps of rotations in 3D space.

7. Quaternion

In a plane (the 2D space), a rotation of a vector has 1 parameter. In 3D space, a rotation of a vector has at least 2 parameters. But a rotation of a 3D rigid body has 3 parameters.

Go ahead, in 4D space, a rotation of a vector has 3 parameters, it is the same number with the parameter of the rotation of a 3D rigid body. This is the foundation of the correspondence between them.

A 4D vector has 4 real parameters, such as w, x, y and z . The 4D axes W, X, Y and Z are perpendicular each other. A 4D vector has 2 projections onto two planes, forming an ordered pair of vectors in a complex plane. When the 4D vector rotates, its length is invariable, thus the sum of the squares of the two length of the two projections is preserved. Thus it remains 3 parameters for the rotation of 4D vector. As in Figure 14.

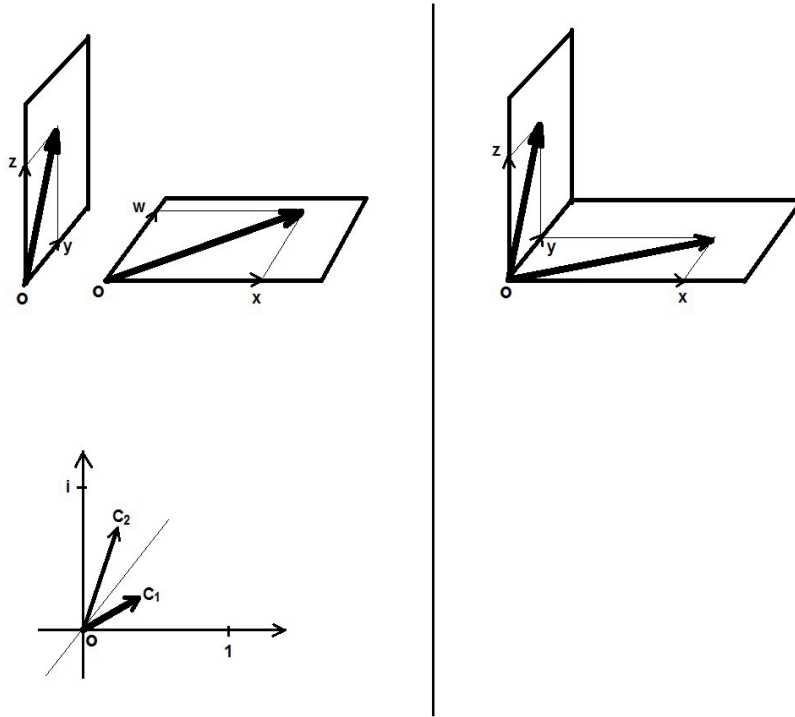

Figure 14

We can draw the two projections in one complex plane, using the ordered pair of complex numbers, to describe the rotation of a vector in 4D space. That is what we have discussed already. The ordered pair of vectors on a complex plane has 3 parameters:

1. the relative angle between the two vectors,
2. the angle which is related with the relative lengths (moduli) of the two vector,
3. the phase angle of the angular bisector of the two vectors, or the phase of the perpendicular line of the angular bisector.

In order to change them to the specified state, corresponding to the result

of the rotation of 3D rigid body, we derived 3 matrices:

$$\begin{aligned} S_z &= \begin{pmatrix} e^{i(\alpha/2)} & 0 \\ 0 & e^{-i(\alpha/2)} \end{pmatrix} = \begin{pmatrix} 1 & 0 \\ 0 & 1 \end{pmatrix} \cos(\alpha/2) + i \begin{pmatrix} 1 & 0 \\ 0 & -1 \end{pmatrix} \sin(\alpha/2) \\ &= \cos(\alpha/2) + i\sigma_z \sin(\alpha/2) = e^{i\sigma_z \alpha/2} \end{aligned}$$

Here the σ_z is one of the Pauli matrices, and $i\sigma_z$ is equivalent to the imaginary unit i of the quaternion. $(i\sigma_z)^2 = -1$.

$$\begin{aligned} S_y &= \begin{pmatrix} \cos(\beta/2) & \sin(\beta/2) \\ -\sin(\beta/2) & \cos(\beta/2) \end{pmatrix} = \begin{pmatrix} 1 & 0 \\ 0 & 1 \end{pmatrix} \cos(\beta/2) + i \begin{pmatrix} 0 & -i \\ i & 0 \end{pmatrix} \sin(\beta/2) \\ &= \cos(\beta/2) + i\sigma_y \sin(\beta/2) = e^{i\sigma_y \beta/2}, \end{aligned}$$

the σ_y is another one of the Pauli matrices, and $i\sigma_y$ is equivalent to the imaginary unit j of the quaternion.

and,

$$\begin{aligned} S_x &= \begin{pmatrix} \cos(\gamma/2) & i \sin(\gamma/2) \\ i \sin(\gamma/2) & \cos(\gamma/2) \end{pmatrix} = \begin{pmatrix} 1 & 0 \\ 0 & 1 \end{pmatrix} \cos(\gamma/2) + i \begin{pmatrix} 0 & 1 \\ 1 & 0 \end{pmatrix} \sin(\gamma/2) \\ &= \cos(\gamma/2) + i\sigma_x \sin(\gamma/2) = e^{i\sigma_x \gamma/2} \end{aligned}$$

the σ_x is also one of the Pauli matrices, and $i\sigma_x$ is equivalent to the imaginary unit k of in the space of the quaternion.

The generators $\sigma_x/2$, $\sigma_y/2$ and $\sigma_z/2$ are half of Pauli matrices, they have the Lie Algebras (or the commutation relations):

$$[\sigma_x/2, \sigma_y/2] = i\sigma_z/2, \quad [\sigma_y/2, \sigma_z/2] = i\sigma_x/2, \quad [\sigma_z/2, \sigma_x/2] = i\sigma_y/2,$$

They obey the same commutation relations of the generators of SO_3 :

$$[J_x, J_y] = iJ_z, \quad [J_y, J_z] = iJ_x, \quad [J_z, J_x] = iJ_y.$$

The intuitive geometry-significance of Pauli matrices and all of the generators, can be viewed in my article *Intuitive Geometric Significance of Pauli Matrices and Others in a Plane*: <http://vixra.org/abs/1710.0198> .

Hongbing Zhang, in Beijing, China.
Email: abada0005@sina.com