

Introduction to Complex Numbers, the History of Complex Numbers and the Complex Field

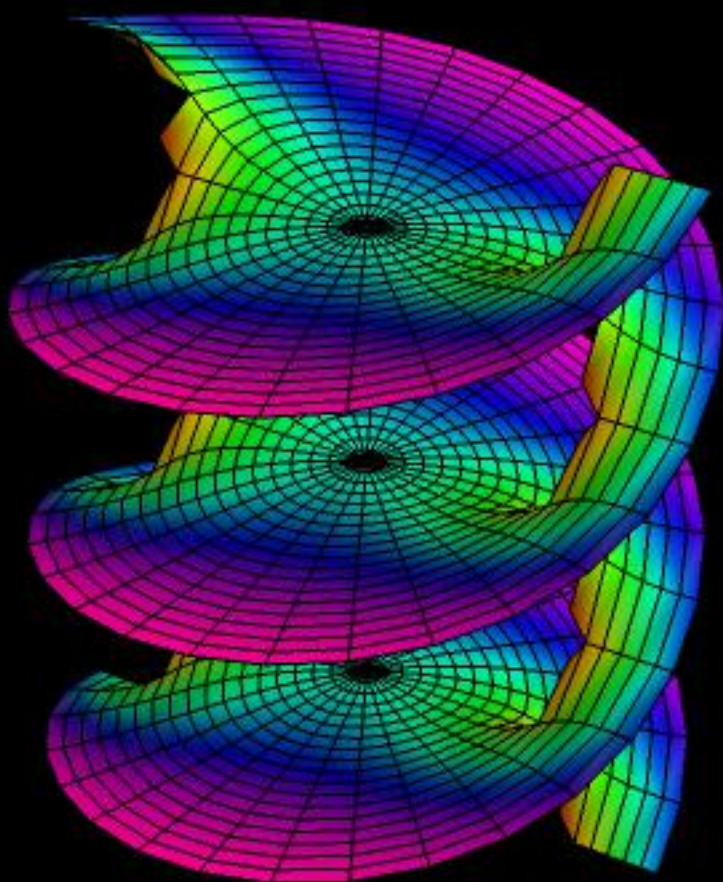

James Bonnar

Introduction to Complex Numbers, the History of Complex Numbers and the Complex Field

James Bonnar

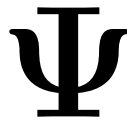

TREASURE TROVE OF MATHEMATICS

September 2022

©2022 by James Bonnar. All rights reserved worldwide under the Berne convention and the World Intellectual Property Organization Copyright treaty.

Fair Use Act Disclaimer: This book is for educational purposes only. Copyright Disclaimer under section 107 of the Copyright Act of 1976, allowance is made for "fair use" for purposes such as criticism, comment, news reporting, teaching, scholarship, education and research.

Limit of Liability/Disclaimer of Warranty: While the publisher and author have used their best efforts in preparing this book, they make no representations or warranties with respect to the accuracy or completeness of the contents of this book and specifically disclaim any implied warranties of merchantability or fitness for a particular purpose. No warranty may be created or extended by sales representatives or written sales materials. The advice and strategies contained herein may not be suitable for your situation. You should consult with a professional where appropriate. Neither the publisher nor author shall be liable for any loss of profit or any other commercial or personal damages, including but not limited to special, incidental, consequential, or other damages.

Imaginary numbers are a fine and wonderful
refuge of the divine spirit almost amphibian
between being and non-being.

Gottfried Wilhelm Leibniz, 1702

Contents

1	Introduction	1
2	Del Ferro, Tartaglia, Cardano & Bombelli	35
3	The Complex Field	53
3.1	The Complex Field	54
3.2	The Complex Plane	57
3.3	Complex Conjugate Numbers	58
3.4	Polar Form of Complex Numbers.	62
3.5	Multiplication and Division in Polar Form. Powers	71
3.6	Roots	73
3.7	Review Examples	80
3.8	Topological Aspects of the Complex Plane	86
3.9	Stereographic Projection; The Point at Infinity	92
3.10	Curves and Regions in the Complex Plane	95
3.11	Exercises	97

Chapter 1

Introduction

In 1450, Johannes Gutenberg finished the invention of the printing press and thereafter books became widely available. This development increased the importance of ideas and information in their own right. The last decades of the fifteenth century marked a period of very intense exploration of many kinds. The academic and intellectual developments that occurred during that time period exemplify the Renaissance era. [advanced calculus](#)

The Renaissance, as it occurred in Europe, was a virtual rebirth of modern society, a resurrection of European thought and culture, after more than one thousand years of oppression imposed during the Medieval period of history. Many artists and intellectuals, in Italy particularly, rediscovered past treasures, and began building upon them. As a result, science and mathematics began to reawaken from the thousand-year sleep as well. [special functions](#)

As the sixteenth century began, Europe felt that it was on the verge of many great things. In the field of mathematics, many new shores began to appear within sight. For example, the solution of quadratic equations had been achieved long before, the quadratic formula having been known since Babylonian times (ca. 1800-1600 BC). But now mathematicians began to seek, and contemplated whether it was even possible to find, a general solution to a cubic equation, in other words, an equation of the form $ax^3 + bx^2 + cx + d = 0$. [the gamma function](#)

2 Chapter 1 Introduction

The quest ultimately led to the recognition of complex numbers, upon which a great deal of modern mathematics, and much of the mathematical theory behind modern science and technology, is ultimately based. Complex analysis ranks amongst the most beautiful, elegant, subtle and powerful of mathematical disciplines. [statistical mechanics](#)

In modern times, we typically simply point out that the quadratic equation $x^2 + 1 = 0$ has no solutions in the field \mathbb{R} of real numbers, because every sum of squares $p^2 + 1$ with $p \in \mathbb{R}$ is positive, and we use that as our call for the existence of complex numbers. But due to the uncomfortable unfamiliarity with such numbers in the sixteenth century, an indirect, but more compulsory path was followed, involving cubics. A new era in mathematics was eventually inaugurated by the final recognition that the inherent incompleteness of \mathbb{R} could be remedied through an extension to the field \mathbb{C} of complex numbers. [abstract algebra](#)

The development of the theory of complex numbers is a striking chapter in the history of mathematics. Complex numbers made their first appearance during the Renaissance, at which time they were often referred to as *impossible quantities*—even negative numbers were yet regarded with some skepticism, a consequence of the then prevalent reliance on classical geometric thinking (which does not admit negative lengths). A precise foundation for the theory of complex numbers would not be laid until the end of the eighteenth century. The quantity $i = \sqrt{-1}$, whose square $i^2 = -1$ is negative, remained suspect and abstruse. [number theory](#)

Two positives make a positive; a negative and a positive make a negative; two negatives make a positive. Why is this? A good common sense explanation is as follows: If one says "do eat", it is encouragement to eat (positive), but if one says "don't eat", the opposite (negative) is being said. Now if one says "don't starve" where "starve"="not eat", one is back to saying "eat". So two negatives make a positive. But the key observation here is that $(++)$ and $(--)$ both give $(+)$. So how can a negative have a square root? [college algebra](#)

One crucial observation is that *positing* the existence of $\sqrt{-1}$ is not equivalent to actually *taking* the square root. It is impossible to actually calculate

the square root of -1 , contrary to what the suggestive symbol $\sqrt{-1}$ might seem to imply. But that does not mean $\sqrt{-1}$ does not exist. Although it is impossible to calculate $\sqrt{-1}$, it nonetheless exists, and we can calculate *with* the quantity. Let's look at some examples of how $\sqrt{-1}$ makes its presence felt: two mathematical, one from physics and one from electronics. [calculus](#)

Example 1.1. The quantity $\ln(1)$ is pure imaginary. A real function with real argument can have a complex result: For the quantity $\ln(1)$ is pure imaginary. But one must be willing to admit complex numbers to *see* this. If $z \in \mathbb{R}$ then it is always the case that

$$(*) \quad e^{\ln(z)} = z \quad \text{and} \quad (**) \quad \ln(e^z) = z.$$

If z is complex, $(*)$ is unremarkable, but $(**)$ merits comment. For suppose we take into consideration Euler's identity $e^{i\pi} + 1 = 0$, or, in other words, $e^{i\pi} = -1$, which is a special case of Euler's formula:

$$e^{ix} = \cos x + i \sin x \quad \forall x \in \mathbb{R}$$

a result that can be easily seen by comparison of the Taylor series expansions of e^x , $\sin x$ and $\cos x$.

In particular, with $x = \pi$, by taking half a turn around the unit circle in \mathbb{C} :

$$e^{i\pi} = \cos \pi + i \sin \pi$$

which gives the identity $e^{i\pi} + 1 = 0$. Now squaring both sides of $e^{i\pi} = -1$ gives $e^{i2\pi} = 1$, and then using $(**)$ might *seem* to imply

$$\ln(e^{2\pi i}) = \ln(1) = \ln(e^0),$$

but that would be wrong, that $2\pi i = 0$.

Over the complex field \mathbb{C} , $1 \not\equiv e^0$, but rather $1 \equiv e^{0+i2\pi n}$. What we actually should write then is not $(e^{i\pi})^2 = 1$, but rather $(e^{i\pi})^{2n} = 1$ which, when we use $(**)$, yields

$$\ln(e^{i2\pi n}) = \ln(1) = i2\pi n \quad n = 0, \pm 1, \pm 2, \dots$$

So, $\ln(1)$ has a zero real part, but in writing $\ln(1) = 0$, we in effect only recognize one of an infinitude of possible purely imaginary values; namely the one with zero imaginary part. In general, $\ln(1)$ is a complex quantity that is legitimately considered pure imaginary, always having zero real part. [trigonometry](#) ■

Example 1.2. Using complex mathematics to perform real mathematics – Cauchy’s residue theorem applied to real integrals. Cauchy’s residue theorem is a powerful tool to evaluate line integrals of analytic functions over closed curves and can often be used to compute real integrals as well. Don’t panic if you don’t understand the material that follows; it is all clearly explained later in the book. This material is simply meant to serve as a preview. [introductory physics](#)

If a complex function is analytic (*syn.* holomorphic) on a region R , it is infinitely differentiable in R . A complex function may fail to be analytic at one or more points through the presence of singularities, or through the presence of branch cuts. A single-valued function that is analytic in all but a discrete subset of its domain, in other words at isolated points, and at those singularities goes to infinity like a polynomial (i.e., these exceptional points are poles), is called a meromorphic function. f has a pole of order n at z_0 if n is the smallest positive integer for which $(z - z_0)^n f(z)$ is analytic at z_0 . [computers on sale](#)

Definition 1.1. A function f has a pole at z_0 if it can be represented by a Laurent series centered about z_0 with only finitely many terms of negative exponent, i.e.,

$$f(z) = \sum_{k=-n}^{\infty} a_k (z - z_0)^k$$

in some neighborhood of z_0 , with $a_{-n} \neq 0$, for $n \in \mathbb{N}$. The number n is called the order of the pole. A simple pole is a pole of order 1.

Definition 1.2. The constant a_{-1} in the Laurent series

$$f(z) = \sum_{k=-\infty}^{\infty} a_k (z - z_0)^k$$

of $f(z)$ about a point z_0 is called the residue of $f(z)$. The residue of a function f at a point z_0 is denoted $\text{Res}(f; z_0)$.

The residues of a function $f(z)$ may be found without explicitly expanding into a Laurent series. If $f(z)$ has a pole of order n at z_0 , then $a_k = 0$ for $k < -n$ and $a_{-n} \neq 0$. [diamond rings](#)

Thus,

$$f(z) = \sum_{k=-n}^{\infty} a_k (z - z_0)^k = \sum_{k=0}^{\infty} a_{k-n} (z - z_0)^{k-n}$$

$$(z - z_0)^n f(z) = \sum_{k=0}^{\infty} a_{k-n} (z - z_0)^k.$$

Differentiating,

$$\begin{aligned} \frac{d}{dz} [(z - z_0)^n f(z)] &= \sum_{k=0}^{\infty} k a_{k-n} (z - z_0)^{k-1} \\ &= \sum_{k=1}^{\infty} k a_{k-n} (z - z_0)^{k-1} \\ &= \sum_{k=0}^{\infty} (k+1) a_{k-n+1} (z - z_0)^k. \end{aligned}$$

$$\begin{aligned} \frac{d^2}{dz^2} [(z - z_0)^n f(z)] &= \sum_{k=0}^{\infty} k(k+1) a_{k-n+1} (z - z_0)^{k-1} \\ &= \sum_{k=1}^{\infty} k(k+1) a_{k-n+1} (z - z_0)^{k-1} \\ &= \sum_{k=0}^{\infty} (k+1)(k+2) a_{k-n+2} (z - z_0)^k. \end{aligned}$$

6 Chapter 1 Introduction

Iterating,

$$\begin{aligned} & \frac{d^{n-1}}{dz^{n-1}} [(z - z_0)^n f(z)] \\ &= \sum_{k=0}^{\infty} (k+1)(k+2) \cdots (k+n-1) a_{k-1} (z - z_0)^k \\ &= (n-1)! a_{-1} \\ &+ \sum_{k=1}^{\infty} (k+1)(k+2) \cdots (k+n-1) a_{k-1} (z - z_0)^k \end{aligned}$$

so we have

$$\begin{aligned} & \lim_{z \rightarrow z_0} \frac{d^{n-1}}{dz^{n-1}} [(z - z_0)^n f(z)] \\ &= \lim_{z \rightarrow z_0} (n-1)! a_{-1} + 0 \\ &= (n-1)! a_{-1} \end{aligned}$$

and the residue is

$$a_{-1} = \frac{1}{(n-1)!} \frac{d^{n-1}}{dz^{n-1}} [(z - z_0)^n f(z)]_{z=z_0}.$$

Proposition 1.1. In the case that $\lim_{z \rightarrow z_0} (z - z_0) f(z)$ exists and has a non-zero value r , the point $z = z_0$ is a pole of order 1 for the function f and

$$\text{Res}(f; z_0) = r,$$

which follows directly from the preceding discussion. [mathematical methods for physicists](#)

For example, we can determine the residue at a simple pole as follows:

$$\begin{aligned} \text{Res}_{z=z_0} \frac{7z+i}{z(z^2+1)} &= \lim_{z \rightarrow i} (z-i) \frac{7z+i}{z(z+i)(z-i)} \\ &= \left[\frac{7z+i}{z(z+i)} \right]_{z=i} = \frac{8i}{-2} = -4i. \end{aligned}$$

Cauchy's residue theorem is stated as follows: Suppose U is a simply connected open subset of the complex plane, and a_1, \dots, a_n are finitely many points of U and also suppose f is a function which is defined and analytic on $U \setminus \{a_1, \dots, a_n\}$, which is to say f is a meromorphic function that is not analytic specifically at the discrete set of points $\{a_1, \dots, a_n\}$. If γ is a rectifiable curve in U which does not meet any of the a_k , and whose start point equals its endpoint, then

$$\oint_{\gamma} f(z) dz = 2\pi i \sum_{k=1}^n I(\gamma, a_k) \operatorname{Res}(f, a_k).$$

Here, $\operatorname{Res}(f, a_k)$ denotes the residue of f at a_k , while $I(\gamma, a_k)$ is the winding number of the curve γ about the point a_k . This winding number is an integer which intuitively measures how many times the curve γ winds around the point a_k ; it is positive if γ moves in a counterclockwise manner around a_k , negative if γ moves around a_k in a clockwise manner, and 0 if γ doesn't move around a_k at all. [group theory](#)

In order to evaluate real integrals, the residue theorem is used in the following manner: the integrand is extended to the complex plane and its residues are computed (which is usually simple), and a part of the real axis is extended to a closed curve by attaching a half-circle in the upper or lower half-plane, forming a semicircle. The integral over this curve can then be computed using the residue theorem. Often, the half-circle part of the integral will tend towards zero as the radius of the half-circle grows, leaving only the real-axis part contributing to the integral, the one we were originally interested in. [linear algebra](#)

There will be a need for bounding the absolute value of complex line integrals. The formula is

$$\left| \int_C f(z) dz \right| \leq ML \quad (\text{ML-inequality})$$

where L is the length of C and M is a constant such that $|f(z)| \leq M$ everywhere on C .

Consider the integral

$$\int_{-\infty}^{\infty} \frac{e^{itx}}{x^2 + 1} dx$$

which arises in probability theory. Its solution is resistant to elementary calculus techniques, but can be evaluated by expressing it as a limit of contour integrals. [tensor theory](#)

Suppose $t > 0$ and define the contour C that goes along the real line from $-R$ to R and then counterclockwise along a semicircle centered at 0 from R to $-R$. Take R to be greater than 1, so that the imaginary unit i is enclosed within the curve. The contour is shown in Figure 1.1. The contour integral is given by

$$\int_C f(z) dz = \int_C \frac{e^{itz}}{z^2 + 1} dz.$$

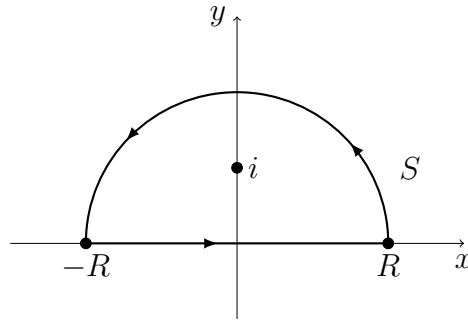

Figure 1.1: Path C of the contour integral.

Since e^{itz} is an entire function (having no singularities at any point in the complex plane), this function has singularities only where the denominator $z^2 + 1$ is zero. Since $z^2 + 1 = (z + i)(z - i)$, that happens only where $z = i$ or $z = -i$. Only one of those points is in the region bounded by the given contour. [complex analysis](#)

Because $f(z)$ is

$$\frac{e^{itz}}{z^2 + 1} = \frac{e^{itz}}{2i} \left(\frac{1}{z - i} - \frac{1}{z + i} \right)$$

the residue of $f(z)$ at $z = i$ is

$$\operatorname{Res}_{z=i} f(z) = \frac{e^{-t}}{2i}.$$

According to the residue theorem, then, we have

$$\int_C f(z) dz = 2\pi i \cdot \operatorname{Res}_{z=i} f(z) = 2\pi i \frac{e^{-t}}{2i} = \pi e^{-t}$$

The contour C may be split into a straight part and a curved arc,

$$\int_{-R}^R f(x) dx + \int_S f(z) dz = \pi e^{-t}$$

and thus

$$\int_{-R}^R f(x) dx = \pi e^{-t} - \int_S f(z) dz.$$

Using some estimations, we have

$$\begin{aligned} \left| \int_S \frac{e^{itz}}{z^2 + 1} dz \right| &\leq \int_S \left| \frac{e^{itz}}{z^2 + 1} \right| |dz| = \int_S \frac{|e^{itz}|}{|z^2 + 1|} |dz| \\ &\leq \int_S \frac{1}{|z^2 + 1|} |dz| \leq \int_S \frac{1}{R^2 - 1} |dz| = \frac{\pi R}{R^2 - 1} \rightarrow 0 \text{ as } R \rightarrow \infty. \end{aligned}$$

Therefore, for $t > 0$, we have

$$\int_{-\infty}^{\infty} \frac{e^{itz}}{z^2 + 1} dz = \pi e^{-t}.$$

If $t < 0$ then a similar argument with an arc C' that winds around $-i$ rather than i shows that

$$\int_{-\infty}^{\infty} \frac{e^{itz}}{z^2 + 1} dz = \pi e^t,$$

so we conclude that

$$\int_{-\infty}^{\infty} \frac{e^{itz}}{z^2 + 1} dz = \pi e^{-|t|}.$$

If $t = 0$ then the integral can be performed using elementary calculus methods and its value is π . [functional analysis](#)

Next we consider real, improper integrals of rational functions $f(x)$ of the type

$$\int_{-\infty}^{\infty} f(x) dx,$$

where it is assumed that the degree of the denominator of $f(x)$ is at least two units higher than the degree of its numerator.

Consider the contour integral corresponding to the above mentioned improper integral of a rational function,

$$\oint_C f(z) dz,$$

around the semicircular path C , similar to that shown in Figure 1.1. Since $f(x)$ is rational, $f(z)$ has finitely many poles in the upper (or lower) half-plane, and if R is sufficiently large, then C encloses all these poles. By the residue theorem we obtain

$$\oint_C f(z) dz = \int_S f(z) dz + \int_{-R}^R f(x) dx = 2\pi i \sum \text{Res } f(z)$$

where the sum consists of all the residues of $f(z)$ at the points in the upper half-plane at which $f(z)$ has a pole. From this we have

$$\int_{-R}^R f(x) dx = 2\pi i \sum \text{Res } f(z) - \int_S f(z) dz.$$

Now if $R \rightarrow \infty$, the value of the integral over the arc S approaches zero. If we set $z = Re^{i\theta}$, then S is represented by $R = \text{constant}$, and as z ranges along S , the variable θ ranges from 0 to π . Since, by assumption, the degree of the denominator of $f(z)$ is at least two units higher than the degree of the numerator, we have that

$$|f(z)| < \frac{k}{|z|^2} \quad (|z| = R > R_0)$$

for sufficiently large constants k and R_0 . So by the ML-inequality,

$$\left| \int_S f(z) dz \right| < \frac{k}{R^2} \pi R = \frac{k\pi}{R} \quad (R > R_0).$$

As $R \rightarrow \infty$, the value of the integral over S approaches zero, and we arrive at

$$\int_{-\infty}^{\infty} f(x) dx = 2\pi i \sum \text{Res } f(z),$$

where we sum over all the residues of $f(z)$ corresponding to the poles of $f(z)$ in the upper half-plane. [vector analysis](#)

As an example, consider the following improper integral of a rational:

$$\int_0^{\infty} \frac{dx}{1+x^4}.$$

The complex function $f(z) = 1/(1+z^4)$ has four simple poles at the points

$$z_1 = e^{\pi i/4}, \quad z_2 = e^{3\pi i/4}, \quad z_3 = e^{-3\pi i/4}, \quad z_4 = e^{-\pi i/4}.$$

The first two of these poles lie in the upper half-plane. Through application of L'Hôpital's rule we find the corresponding residues to be

$$\begin{aligned} \operatorname{Res}_{z=z_1} f(z) &= \left[\frac{z-z_1}{1+z^4} \right]_{z=z_1} = \left[\frac{1}{4z^3} \right]_{z=z_1} \\ &= \frac{1}{4} e^{-3\pi i/4} = -\frac{1}{4} e^{\pi i/4} \end{aligned}$$

$$\begin{aligned} \operatorname{Res}_{z=z_2} f(z) &= \left[\frac{z-z_2}{1+z^4} \right]_{z=z_2} = \left[\frac{1}{4z^3} \right]_{z=z_2} \\ &= \frac{1}{4} e^{-9\pi i/4} = \frac{1}{4} e^{-\pi i/4} \end{aligned}$$

And through the use of the identity

$$\sin z = \frac{1}{2i}(e^{iz} - e^{-iz}),$$

we arrive at

$$\int_{-\infty}^{\infty} \frac{dx}{1+x^4} = \frac{2\pi i}{4}(-e^{\pi i/4} + e^{-\pi i/4}) = \pi \sin \frac{\pi}{4} = \frac{\pi}{\sqrt{2}}.$$

Since $1/(1+x^4)$ is an even function, we finally obtain

$$\int_0^{\infty} \frac{dx}{1+x^4} = \frac{1}{2} \int_{-\infty}^{\infty} \frac{dx}{1+x^4} = \frac{\pi}{2\sqrt{2}}.$$

■

Example 1.3. Quantum mechanical states are represented by vectors in a (possibly infinite-dimensional) complex vector space. Now we digress from pure mathematics to demonstrate the necessity of complex numbers in describing the physical world. Here we consider the Stern-Gerlach experiment—an experiment involving a 2-state system which demonstrates the fact that quantum mechanical states are to be represented by vectors in an abstract complex vector space (note that functions, including wavefunctions, can be thought of as infinite-dimensional vectors in the sense that each abscissa can be thought of as an "axis", while each corresponding ordinate value can be thought of as the value along that axis). We will finish by making an analogy with the polarization of light. [Fourier analysis](#)

Quantum states are always vectors in an abstract vector space (technically, a complex Hilbert space). For quantum wave functions, the Hilbert space usually has not only infinite dimensions, but uncountably infinitely many dimensions. Each wave function corresponds to a quantum state, which can be thought of as a vector in the state space, which is a Hilbert space. However, linear algebra is much simpler for finite-dimensional vector spaces. Therefore it is helpful to look at an example from quantum mechanics where the Hilbert space of wave functions is finite dimensional. In quantum mechanics, every finite-dimensional Hilbert space can be considered a *spin space*. [real analysis](#)

In formulating the Dirac equation for the electron, Paul Dirac combined relativity with the quantum wavefunction. He explained that quantum spin is ultimately a relativistic effect. Phenomenologically speaking, the effects to which the term *spin* refers will be explained below.

As shown in Figure 1.2, in the Stern-Gerlach experiment, first, silver (Ag) atoms are heated in an oven that has a small hole through which some of the silver atoms manage to escape, which are then beamed through a collimator and subsequently subjected to an inhomogeneous magnetic field produced by a pair of magnetic poles, one of which has a very sharp edge. The magnetic field is chosen to be inhomogeneous such that the force on one end of the atomic dipole will be slightly greater than the opposing force on the other end, so that there is a net force which deflects the particle's trajectory. [dynamical systems](#)

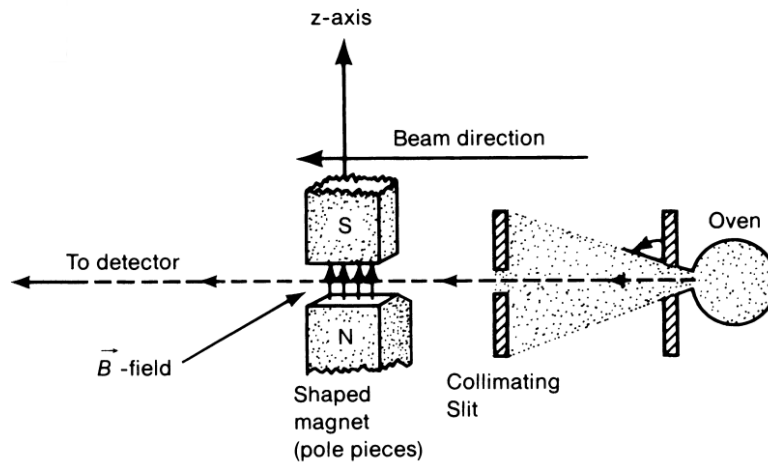

Figure 1.2: The Stern-Gerlach experiment.

The silver atom is made up of a nucleus and 47 electrons, where 46 out of the 47 electrons can be visualized as forming an approximately spherically symmetrical electron cloud with no net angular momentum. Ignoring nuclear spin, the atom as a whole does have an angular momentum, due solely to the intrinsic (not orbital) spin angular momentum possessed by the 47th (5S) electron. The spins of the other 46 electrons cancel as far as atomic angular momentum is concerned due to the Pauli exclusion principle, which states no two electrons in an atom may possess the same quantum states, and Hund's rule, which states that every orbital in a sub-shell is singly occupied with one electron before any one orbital is doubly occupied, and all electrons in singly occupied orbitals have the same spin. The 47 electrons are attracted to the nucleus, which is $\sim 2 \times 10^5$ times heavier than an electron; as a result, the atom nets a magnetic moment equal to the spin magnetic moment of the 47th electron. That is to say, the magnetic moment μ of the atom is proportional to the electron spin S , stated $\mu \propto S$ (the proportionality factor is usually taken to be a negative number). [differential equations](#)

The magnetic moment of a magnet is a vector quantity that determines the force the magnet can exert on moving electric charges and the torque that an external magnetic field would exert upon it. The magnetic mo-

ment has magnitude and direction. The direction of the magnetic moment points from the south to north pole of a magnet, an arbitrary convention. The magnetic field produced by a magnet is proportional to its magnetic moment. To be precise, the term 'magnetic moment' normally refers to a system's magnetic dipole moment, which produces the first term in the multipole expansion of a general magnetic field. The dipole component of an object's magnetic field is symmetric about the direction of its magnetic dipole moment, and decreases as the inverse cube of the distance from the object. [differential geometry](#)

Now, $\boldsymbol{\mu}$ and \mathbf{B} are defined such that the interaction energy of the magnetic moment with the magnetic field is just $-\boldsymbol{\mu} \cdot \mathbf{B}$, so the z -component of the force experienced by our silver atom is given by

$$F_z = \frac{\partial}{\partial z}(\boldsymbol{\mu} \cdot \mathbf{B}) \simeq \mu_z \frac{\partial B_z}{\partial z} \cos \theta,$$

which mathematically states that the pull and push of the magnetic field in the z -direction upon the silver atom is proportional to its magnetic moment, to the ratio of the amount of rotation of the moment with or against the field to movement of the atom in the z -direction, to the degree of alignment, and to the degree of inhomogeneity of the magnetic field. Since the atom is much heavier than an electron, the classical concept of trajectory will suffice in this case (indeterminacy of position is not considered here).

The silver atoms in the oven are randomly oriented; as is each $\boldsymbol{\mu}$. If the electron were a classical spinning object, we would expect all values of μ_z to be realized between $|\mu|$ and $-|\mu|$; in other words, we would expect to detect a continuous bundle of beams as shown in Figure 1.3a. But what we experimentally observe is that the Stern-Gerlach apparatus splits the initial silver beam from the oven into two distinct components as shown in Figure 1.3b – this phenomenon used to be known as "space quantization". Since $\boldsymbol{\mu} \propto \mathbf{S}$, only two possible values of the z -component of \mathbf{S} are observed to be possible, S_z up (spin-up) and S_z down (spin down), labelled S_z+ and S_z- , respectively. Assuming the north pole of the magnet rests upon the table, situated below the south pole, the $\mu_z > 0$ ($S_z < 0$, or spin-down) atom experiences a downward force, while the $\mu_z < 0$ ($S_z > 0$, or spin-up) atom experiences an upward force. The beam splits according to the values of μ_z . The Stern-Gerlach apparatus measures the z -component of $\boldsymbol{\mu}$ and the

z -component of S up to a proportionality factor. The two possible values of S_z are multiples of some fundamental unit of angular momentum, which we get to momentarily. [topology](#)

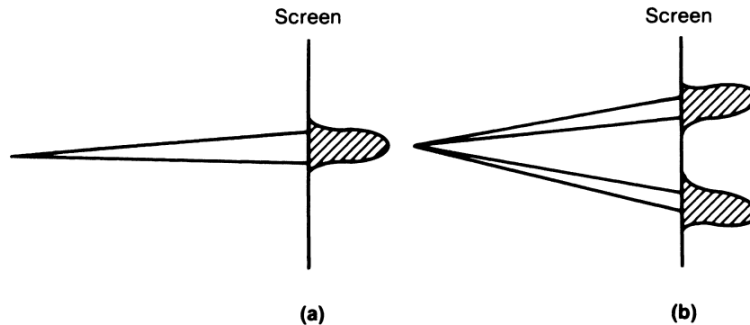

Figure 1.3: Beams from the SG apparatus; (a) is expected from classical physics, while (b) is actually observed.

It turns out that every elementary particle has a specific, immutable value associated with it called the magnetic quantum number s , which we commonly call the spin. The magnetic quantum number can be viewed as a vector component of the total spin angular momentum S . In solving the Schrödinger equation, the total spin angular momentum for a spin-1/2 particle is given by

$$S = \sqrt{\frac{1}{2} \left(\frac{1}{2} + 1 \right)} \hbar = \frac{\sqrt{3}}{2} \hbar$$

The value of the reduced Planck constant \hbar is:

$$\hbar = \frac{h}{2\pi} = 1.0546 \times 10^{-34} \text{ J} \cdot \text{s} = 4.1357 \times 10^{-15} \text{ eV} \cdot \text{s}$$

The Planck constant has dimensions of physical action, which are the same as those of angular momentum (i.e., $L = r \times p = r \times mv$); or in other words, energy multiplied by time, or momentum multiplied by distance. The magnetic quantum number, viewed as a vector component of the total spin angular momentum S along one axis, can only have the values $\pm\hbar/2$. In terms of natural constants, these values for angular momentum are

functions only of the reduced Planck constant, with no dependence on mass or charge.

The necessity of introducing half-integral spin goes back to the results of the Stern-Gerlach experiment. Since the beam split in two (there is no undeflected beam), the ground state therefore could not be integral, because even if the intrinsic angular momentum of the atoms were as small as possible, 1, the beam would be split into three parts, corresponding to atoms with $L_z = -1, 0,$ and $+1$. The conclusion was that silver atoms had net intrinsic angular momentum of $1/2$. [algebraic geometry](#)

In the case of the electron, the two possible values of S_z are multiples of the fundamental unit of angular momentum, namely $S_z = \hbar/2$ and $-\hbar/2$. This quantization of electron spin angular momentum is the first important property deduced from the Stern-Gerlach experiment. The other property we now embark on deducing demonstrates the importance of complex numbers in describing the natural world at a fundamental level.

Consider that, in the Stern-Gerlach apparatus, we could just as well apply an inhomogeneous field in a horizontal direction, say in the x -direction, with the beam proceeding in the y -direction. Then the beam would separate into S_x+ and S_x- components. So now let's consider a sequential Stern-Gerlach experiment, as shown in Figure 1.4, in which the atomic beam passes through two or more Stern-Gerlach apparatuses in sequence. Let a symbol such as $SG\hat{z}$ stand for an apparatus with an inhomogeneous magnetic field in the z -direction, and so on. [graph theory](#)

Sequential SG case 1: We have the atomic beam pass through an $SG\hat{z}$ apparatus, but then block the S_z- component, yet have the S_z+ component beam again pass through another $SG\hat{z}$ apparatus, from which only an S_z+ component emerges. No S_z- component emerges. There is no surprise in this result.

Sequential SG case 2: Have the atomic beam pass through an $SG\hat{z}$ apparatus, and again block the S_z- component, but then pass the S_z+ component beam through an $SG\hat{x}$ apparatus from which an S_x+ component beam and an S_x- component beam emerge. Again no surprise.

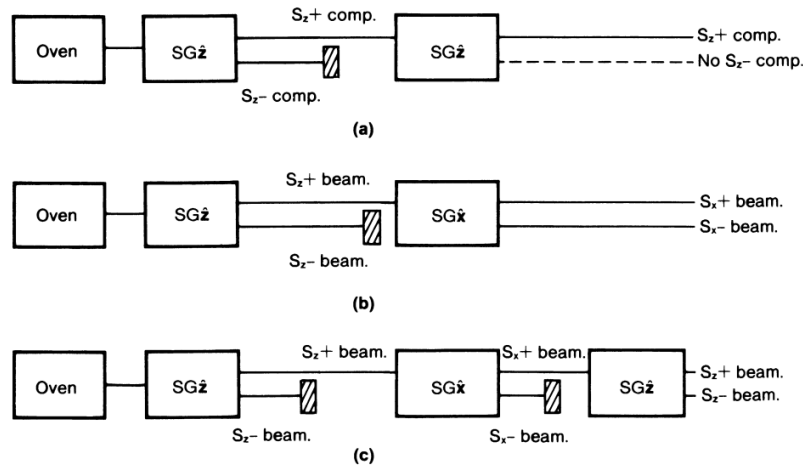

Figure 1.4: Sequential Stern-Gerlach experiments.

Sequential SG case 3: Once again have the atomic beam pass through an $SG\hat{z}$ apparatus, and block the S_z- component, pass the remaining S_z+ beam through an $SG\hat{x}$ apparatus and block the S_x- beam. Now, when the remaining S_x+ beam is passed through an $SG\hat{z}$ apparatus, both an S_z+ beam and an S_z- beam emerge! That result is quite surprising and is the reason complex numbers are necessary to describe nature fundamentally.

Quantum mechanics says one cannot determine both S_z and S_x simultaneously. The selection of the S_x+ beam by the second $SG\hat{x}$ apparatus destroyed any previous information about S_z .

Now by making an analogy with the polarization of light, we shall see clearly that quantum mechanical states are to be represented by vectors in a complex vector space. [partial differential equations](#)

Let's consider a monochromatic light wave propagating in the z -direction. Linearly polarized (plane polarized) light with a polarization vector in the x -direction, call it x -polarized light for short, has an electric field oscillating in the x -direction through spacetime,

$$\mathbf{E} = E_0 \hat{x} \cos(kz - \omega t).$$

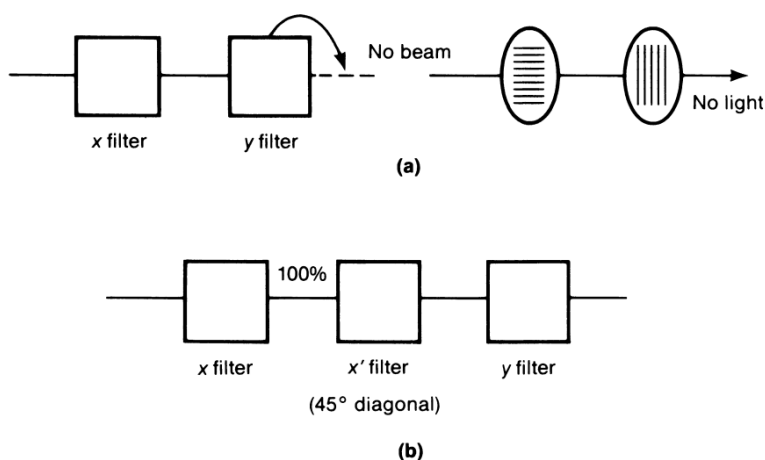

Figure 1.5: Light beams subjected to Polaroid filters.

We may likewise consider *y*-polarized light, also propagating in the *z*-direction,

$$\mathbf{E} = E_0 \hat{\mathbf{y}} \cos(kz - \omega t).$$

Polarized light beams of the above mentioned type are produced by passing unpolarized light through a polaroid filter, as shown in Figure 1.5. A filter that selects only beams in the *x*-direction is called an *x*-filter. An *x*-filter becomes a *y*-filter simply by rotating it 90° about the propagation (*z*) direction. If a light beam is passed through an *x*-filter, then subsequently through a *y*-filter, no light emerges. [classical mechanics](#)

The experimental observation becomes quite fascinating if we insert between the *x*-filter and the *y*-filter yet another polaroid that selects only light that is polarized in the *x'*-direction – making an angle of 45° with the *x*-direction in the *xy* plane, as shown in Figure 1.6. Now a light beam emerges from the *y*-filter despite the fact that after the beam went through the *x*-filter it did not have any polarization component in the *y*-direction. Once the *x'*-filter selects the *x'*-polarized beam, all previous information on light polarization is destroyed. Notice the analogy to the situation we encountered earlier in the sequential SG experiments, if the following

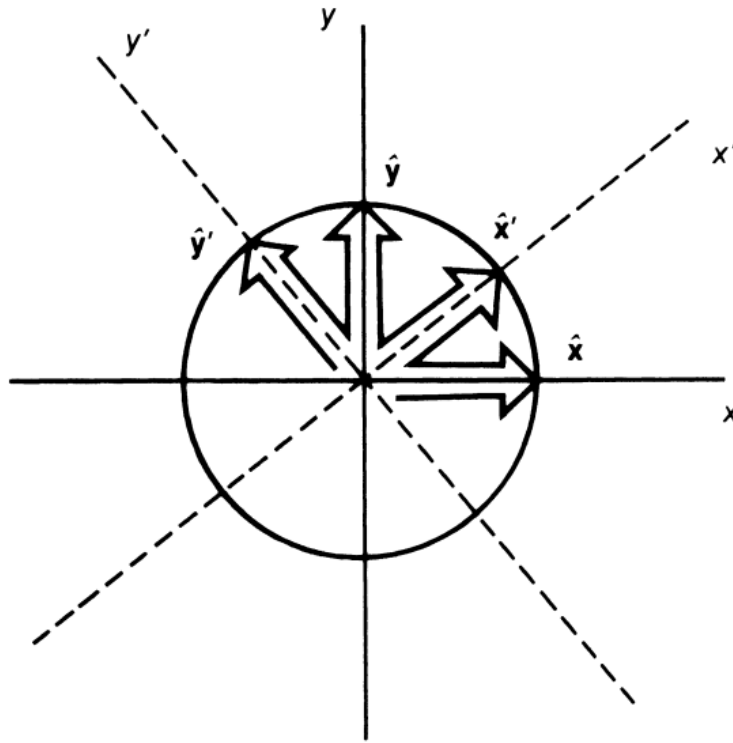

Figure 1.6: Orientations of the x' and y' -axes.

correspondences are made

$$S_z \pm \text{atoms} \leftrightarrow x\text{-, } y\text{-polarized light}$$

$$S_x \pm \text{atoms} \leftrightarrow x'\text{-, } y'\text{-polarized light}$$

where the x' - and y' -axes are at 45° angles with respect to the x - and y -axes.

Now examine how we may mathematically describe the 45° -polarized beams (the x' - and y' -polarized beams) using only classical electrodynamics. Using

Figure 1.6 and the Pythagorean theorem we get

$$\begin{aligned}
 & E_0 \hat{\mathbf{x}}' \cos(kz - \omega t) \\
 &= E_0 \left[\frac{1}{\sqrt{2}} \hat{\mathbf{x}} \cos(kz - \omega t) + \frac{1}{\sqrt{2}} \hat{\mathbf{y}} \cos(kz - \omega t) \right], \\
 & E_0 \hat{\mathbf{y}}' \cos(kz - \omega t) \\
 &= E_0 \left[-\frac{1}{\sqrt{2}} \hat{\mathbf{x}} \cos(kz - \omega t) + \frac{1}{\sqrt{2}} \hat{\mathbf{y}} \cos(kz - \omega t) \right].
 \end{aligned}$$

In the triple-filter arrangement the beam coming out of the first polaroid is an x -polarized beam, which can be regarded as a linear combination of an x' -polarized beam and a y' -polarized beam. The second filter selects the x' -polarized beam, which can in turn be regarded as a linear combination of an x -polarized beam and a y -polarized beam. And finally, the third filter selects the y -polarized component.

The correspondence between the third sequential SG experiment and the triple-filter experiment suggests that we may be able to represent the spin state of a silver atom by a vector in an abstract two-dimensional vector space, not to be confused with the usual two-dimensional (xy) space. Just as $\hat{\mathbf{x}}'$ and $\hat{\mathbf{y}}'$ are the base vectors used to decompose the polarization vectors $\hat{\mathbf{x}}$ and $\hat{\mathbf{y}}$, it is reasonable to represent the S_x+ and S_x- states by vectors, called *kets* in the notation of Dirac. We denote these vectors by $|S_x; +\rangle$ and $|S_x; -\rangle$ respectively. So we are free to conjecture in analogy that

$$\begin{aligned}
 |S_x; +\rangle &= \frac{1}{\sqrt{2}} |S_z; +\rangle + \frac{1}{\sqrt{2}} |S_z; -\rangle \\
 |S_x; -\rangle &= -\frac{1}{\sqrt{2}} |S_z; +\rangle + \frac{1}{\sqrt{2}} |S_z; -\rangle
 \end{aligned}$$

That this is the case is the reason that two components emerge from the third SG \hat{z} apparatus.

But the next question is how to represent the $S_y\pm$ states. By symmetry, an $S_z\pm$ beam going in the x -direction passing through an SG \hat{y} apparatus ought to be similar to the case where an $S_z\pm$ beam goes in the y -direction and passes through an SG \hat{x} apparatus. The kets for $S_y\pm$ should then also be regarded as a linear combination of $|S_z; \pm\rangle$, but from the two equations

above, it appears we have already exhausted the available possibilities in writing $|S_x; \pm\rangle$. How can our desired vector space formalism distinguish $S_y \pm$ from $S_x \pm$ states?

An analogy with circularly polarized light helps here. Circularly polarized light can be obtained from linearly polarized light by passing it through an optical device known as a quarter-wave plate. A right circularly polarized light is a linear combination of an x -polarized light and a y -polarized light, where the oscillation of the electric field for the y -polarized component is 90° out of phase with that of the x -polarized component:

$$\mathbf{E} = E_0 \left[\frac{1}{\sqrt{2}} \hat{\mathbf{x}} \cos(kz - \omega t) + \frac{1}{\sqrt{2}} \hat{\mathbf{y}} \cos(kz - \omega t + \frac{\pi}{2}) \right].$$

When circularly polarized light is passed through an x -filter or a y -filter, either an x -polarized beam or a y -polarized beam is obtained, of equal intensity. But circularly polarized light is completely different from the 45° -linearly polarized (x' - or y' -polarized) light discussed.

Consider Euler's identity $e^{i\pi} = -1$ which implies $i = e^{i\pi/2}$ and thus for circularly polarized light we can write

$$\varepsilon = \left[\frac{1}{\sqrt{2}} \hat{\mathbf{x}} e^{i(kz - \omega t)} + \frac{i}{\sqrt{2}} \hat{\mathbf{y}} e^{i(kz - \omega t)} \right]$$

where $\text{Re}(\varepsilon) = \mathbf{E}/E_0$ and we used $\text{Re}(e^{i\theta}) = \cos \theta$. We make the following analogy with the atomic spin states:

$$S_y \pm \text{ atoms} \leftrightarrow \text{right-, left- circularly polarized light}$$

Applying this analogy if we are allowed to make the coefficients preceding base kets complex, then there is no difficulty in accommodating the $S_y \pm$ atoms in the vector space formalism:

$$|S_y; \pm\rangle = \frac{1}{\sqrt{2}} |S_z; +\rangle \pm \frac{i}{\sqrt{2}} |S_z; -\rangle.$$

Through these analogies, we see that the two-dimensional vector space needed to describe the spin states of silver atoms must be a complex vector space; an arbitrary vector in the vector space used to represent quantum mechanical states is a linear combination of the base vectors $|S_z; \pm\rangle$ with, in general, complex coefficients. [quantum mechanics](#) ■

Example 1.4. Use of $\sqrt{-1}$ in the field of electronics.

Now we consider Rayleigh's puzzle – a problem that concerns the study of alternating current circuits which was resolved in the late nineteenth century with the help of complex exponentials.

Before discussing the puzzle, we briefly survey a few facts about electricity. Two hundred years ago, the common view of electricity was that of a mysterious fluid flowing along a pipe of wire. Oliver Lodge derisively referred to this view as the "drainpipe theory" of electricity. For direct current flowing through purely resistive circuits the drainpipe theory is perhaps enough, but for alternating current is simply does not suffice.

For many types of materials, specifically metals and carbon, the rate at which electrical charge moves through the material (the current) is directly proportional to the applied voltage. This phenomenon is referred to as Ohm's law. Because it applies only to a limited number of materials, Ohm's law is not a law in the same sense that, say, conservation of energy is.

What is charge? Electrical charge is the property of matter that is the basis for electrical effects. Charge is quantized and occurs in multiples of the charge on one electron which is -1.6×10^{-19} coulombs (the charge on a proton is $+1.6 \times 10^{-19}$ coulombs).

Coulomb's electrostatic force law is somewhat analogous to Newton's inverse-square law for gravitational attraction. One simply substitutes q_1 and q_2 for m_1 and m_2 , and uses Coulomb's constant k_e in place of the gravitational constant G . Similar to Newton's law, the force is along the line between the two charges, but although masses are always positive and the gravitational force is always attractive, electrical charges can be either positive or negative such that the electrostatic force can be either attractive ($q_1 q_2 < 0$) or repulsive ($q_1 q_2 > 0$). Electrically neutral macroscopic matter remains full of charge at the microscopic level – equal amounts of positive and negative charge cancel each other's effects. [relativity](#)

Electrical *current* is the movement of charge. A current of one ampere is said to be flowing through a cross-section of a conductor if one coulomb of charge passes through the cross-section per second. The presence of an electric field is what makes a charge move. An applied voltage is what

creates the electric field in a conductor, and the moving charges are the current. If current could be likened to fluid moving through a pipe, then voltage would be analogous to the pressure.

One of the most basic electrical components are resistors, which are commonly small cylinders of carbon with wire terminals at each end. Resistors are defined to be any device that obeys Ohm's law, $V = IR$, where V is the voltage difference across the two terminals, I is the current through the resistor, and R is the resistance of the device to current flow. R is measured in ohms if V and I are measured in volts and amperes, respectively.

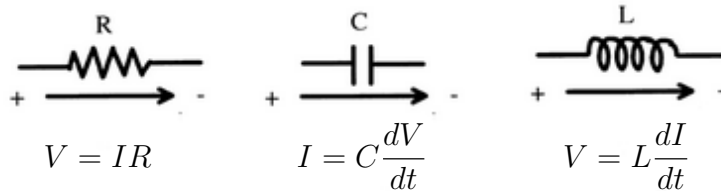

Figure 1.7: Three common components used in electronic circuits: from left to right, the resistor, capacitor and inductor, respectively.

Two other basic components commonly found in electric circuits are the capacitor and the inductor. These electrical components obey the mathematical relationships shown in Figure 1.7, where C and L denote the capacitance and inductance, in farads and henrys, respectively. The figure also depicts the schematic symbols used to denote these electrical components in circuit diagrams. [string theory](#)

The current I in Figure 1.7 flows in the direction of the voltage drop, from the + terminal to the - terminal. The plus/minus symbols do not actually mean plus and minus – the + terminal is simply at a higher voltage than the - terminal is. Both terminals could be positive when compared to ground. For example, consider a +8 volt + terminal and a +2 volt - terminal in which the voltage drop is 6 volts as we move from the + terminal to the - terminal. Electric fields point in the direction of the voltage drop, from the + to the - terminal. However, the actual physical charge carriers,

electrons, with their negative charge will move in the opposite direction, against the electric field, from the $-$ terminal to the $+$ terminal.

There are just two more facts about electricity to learn before we consider Rayleigh's puzzle. Kirchoff's laws are two laws used in circuit analysis that are actually restatements of the conservation laws of energy and charge (neither energy nor charge can be created or destroyed) applied to the special case of electronic circuits.

Voltage law: Around any closed loop, the sum of all the voltage drops across the components is zero.

Current law: The current flux at any given point is zero, or the sum of the currents flowing into a point equal the sum of the currents flowing out of a point.

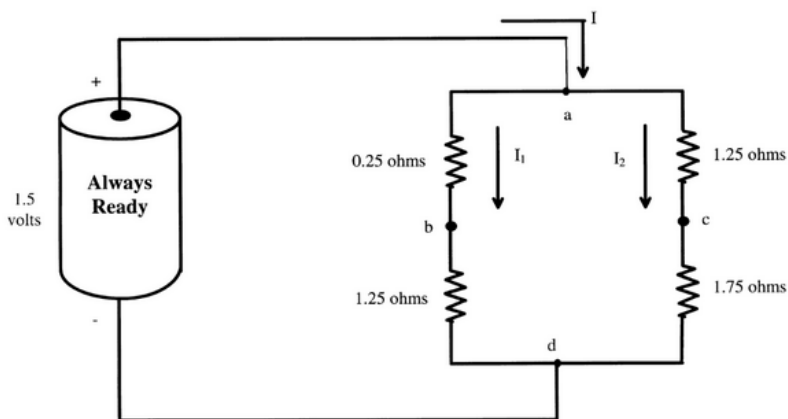

Figure 1.8: A simple resistor circuit.

Now, consider the circuit shown in Figure 1.8. The battery's voltage of 1.5V also occurs across both halves of the right-hand side of the circuit.

Kirchoff's current law demands that $I = I_1 + I_2$. From Ohm's law we have

$$\begin{aligned}V_{ab} &= 0.25I_1, \\V_{bd} &= 1.25I_1, \\V_{ac} &= 1.25I_2, \\V_{cd} &= 1.75I_2.\end{aligned}$$

And from Kirchoff's voltage law, we have

$$\begin{aligned}1.5 &= V_{ab} + V_{bd} = 1.5I_1 \\1.5 &= V_{ac} + V_{cd} = 3I_2\end{aligned}$$

So $I_1 = 1\text{A}$ and $I_2 = 0.5\text{A}$. Take special note of the fact that I_1 and I_2 are both less than $I = 1.5\text{A}$ and would be measured to be so.

Now we are ready to consider Rayleigh's puzzle. We extend the simple circuit of Figure 1.8 to the one shown in Figure 1.9 where all three kinds of electrical components are included and instead of a DC battery we use an AC voltage generator operating at radian frequency ω . This means that if $V(t)$ is a sinusoidal voltage with a maximum amplitude of V_{\max} volts, then $V(t) = V_{\max} \cos(\omega t)$. [scientific computing](#)

The voltage $V(t)$ completes one cycle of oscillation as ωt varies from 0 to 2π . Thus, one cycle of oscillation requires a time of $2\pi/\omega$ seconds. In one second there will be $\omega/2\pi$ cycles, which is the frequency f , so $\omega = 2\pi f$. The unit of frequency is the hertz. One hertz is equivalent to one cycle per second. Since angular frequency ω is the number of radians per unit time, the unit of angular frequency is taken to be the inverse second s^{-1} .

The three circles labelled M , M_1 and M_2 in Figure 1.9 represent current meters with indicator needles that point to current values on a scale.

Current meters such as those used in this example are called *moving coil D'Arsonval meters* – they utilize the magnetic field generated by the current along a wire. Their principle of operation is quite simple. A coil of stiff wire is suspended via low-friction supports in the magnetic field of a magnet. The current to be measured is passed through the coil, and its magnetic field interacts with the magnet's field to produce a net force; this produces

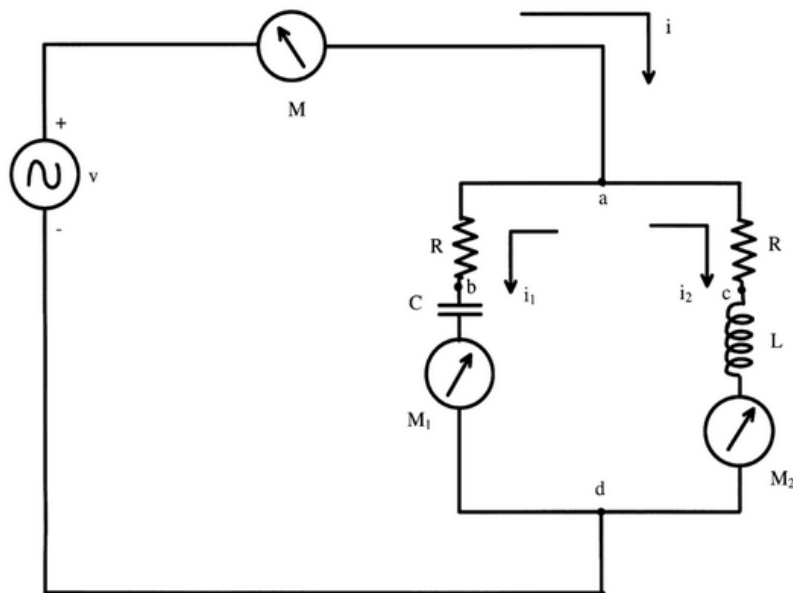

Figure 1.9: Rayleigh's current-splitting puzzle.

a torque that rotates the coil, which moves a needle attached to the coil. The force or torque is proportional to the coil current. If this current varies slowly enough, the coil/needle apparatus can vary along with the current, but if the current varies rapidly the mechanical inertia of the coil/needle apparatus will smooth out the variation such that the meter responds to the average value of the current. [advanced engineering mathematics](#)

Supposing the meter's magnet is a permanent magnet, the torque is proportional to the product of the fields, which is directly proportional to the current in the coil. Such a meter would be useless for measuring AC currents since their average value is zero. But if we replace the permanent magnet with an electromagnet (a second coil wrapped around an iron bar) and run the current through it as well as through the suspended coil, now the two magnetic fields will vary together in response to the AC current. The torque is proportional to the product of the fields just as before, which in this case is directly proportional to the square of the AC current. Therefore, the needle deflection is proportional to the average of the squared current, which is nonzero for AC.

As before, we will now calculate the currents I_1 and I_2 for Figure 1.9. But what we'll find is that while Kirchoff's current law remains satisfied, i.e., $I = I_1 + I_2$, it is possible under certain conditions for I_1 and I_2 to both be measured to be larger than I .

The following mathematical expressions apply to the electronic circuit in Figure 1.9, making use of Kirchoff's laws and the definitions of resistors, capacitors and inductors.

$$\begin{aligned} I &= I_1 + I_2, \\ V &= I_2 R + L \frac{dI_2}{dt}, \\ I_1 &= C \frac{dV_{bd}}{dt}, \\ V &= I_1 R + V_{bd}. \end{aligned}$$

Differentiating the last of these equations gives

$$\frac{dV}{dt} = R \frac{dI_1}{dt} + \frac{1}{C} I_1.$$

This, together with the relation

$$V = I_2 R + L \frac{dI_2}{dt},$$

gives us two differential equations, one for each of the currents I_1 and I_2 . If we assume V is sinusoidal, then the use of complex exponentials makes the solution of these differential equations straightforward, and we will thereby solve Rayleigh's puzzle. [cryptography](#)

We first introduce complex exponentials by writing

$$V(t) = 2V_0 \cos(\omega t) = V_0 e^{i\omega t} + V_0 e^{-i\omega t},$$

where we include a factor of 2 to avoid having to include a factor of 1/2 in all the equations that follow, in other words, we shall halve the results later.

Since $e^{i\theta}$ represents a unit vector in the complex plane making an angle θ with the positive real axis, $e^{i\omega t}$ is a unit vector making an angle ωt that

increases with t . In other words, $e^{i\omega t}$ is a rotating vector that rotates counterclockwise at frequency $\omega/2\pi$ Hz. Similarly, $e^{-i\omega t}$ is a vector rotating clockwise at the same frequency. Counterclockwise rotations are considered positive rotations, whereas clockwise rotations are taken to be negative.

We shall next calculate I_1 and I_2 for just the first term of $V(t)$, i.e., for the $V_0 e^{i\omega t}$ term, and call the results I_1^+ and I_2^+ . Then we repeat the analysis for the second term, i.e., for the $V_0 e^{-i\omega t}$ term, and call the results I_1^- and I_2^- . The solutions for $V(t) = 2V_0 \cos(\omega t)$ will then be

$$\begin{aligned} I_1 &= I_1^+ + I_1^-, \\ I_2 &= I_2^+ + I_2^-. \end{aligned}$$

Since $V^+ = V_0 e^{i\omega t}$ we have $I_1^+ = I_{0,1}^+ e^{i\omega t}$ and $I_2^+ = I_{0,2}^+ e^{i\omega t}$, where $I_{0,1}^+$ and $I_{0,2}^+$ are constants. Substituting V^+ , I_1^+ and I_2^+ into the two differential equations gives

$$\begin{aligned} i\omega V_0 e^{i\omega t} &= i\omega R I_{0,1}^+ e^{i\omega t} + \frac{1}{C} I_{0,1}^+ e^{i\omega t}, \\ V_0 e^{i\omega t} &= R I_{0,2}^+ e^{i\omega t} + i\omega L I_{0,2}^+ e^{i\omega t}, \end{aligned}$$

or, after canceling the common $e^{i\omega t}$ terms,

$$\begin{aligned} i\omega V_0 &= i\omega R I_{0,1}^+ + \frac{1}{C} I_{0,1}^+, \\ V_0 &= R I_{0,2}^+ + i\omega L I_{0,2}^+. \end{aligned}$$

Solving, we find

$$\begin{aligned} I_{0,1}^+ &= \frac{V_0}{R - i\frac{1}{\omega C}}, \\ I_{0,2}^+ &= \frac{V_0}{R + i\omega L}. \end{aligned}$$

If these steps are then repeated for $V^- = V_0 e^{-i\omega t}$ with $I_1^- = I_{0,1}^- e^{-i\omega t}$ and $I_2^- = I_{0,2}^- e^{-i\omega t}$, the results are

$$I_{0,1}^- = \frac{V_0}{R + i\frac{1}{\omega C}},$$

$$I_{0,2}^- = \frac{V_0}{R - i\omega L}.$$

Therefore, the currents I_1 and I_2 are, for $V(t) = 2V_0 \cos(\omega t)$,

$$I_1 = I_{0,1}^+ e^{i\omega t} + I_{0,1}^- e^{-i\omega t} = \frac{V_0}{R - i\frac{1}{\omega C}} e^{i\omega t} + \frac{V_0}{R + i\frac{1}{\omega C}} e^{-i\omega t}$$

and

$$I_2 = I_{0,2}^+ e^{i\omega t} + I_{0,2}^- e^{-i\omega t} = \frac{V_0}{R + i\omega L} e^{i\omega t} + \frac{V_0}{R - i\omega L} e^{-i\omega t}.$$

The expressions for I_1 and I_2 appear complex, but they're actually purely real. This must be so for two reasons, one physical and one mathematical. The physical reason is that if we apply the real voltage $V(t) = 2V_0 \cos(\omega t)$ to a circuit made of physical hardware, then all the voltages and currents (observables) must be real too. Mathematically, we note that both I_1 and I_2 are the sums of two terms which are complex conjugates. Such a sum is equivalent to twice the real part of either term. Now since the above expressions for I_1 and I_2 are the currents for $V(t) = 2V_0 \cos(\omega t)$, the currents for $V(t) = V_0 \cos(\omega t)$ are half as much, so we have

$$I_1 = \text{Re} \left\{ \frac{V_0}{R - i\frac{1}{\omega C}} e^{i\omega t} \right\},$$

$$I_2 = \text{Re} \left\{ \frac{V_0}{R + i\omega L} e^{i\omega t} \right\}.$$

We can find the real part of these expressions through an application of the identity for the inverse of a complex number which is

$$\frac{1}{a + bi} = \frac{1}{a + bi} \cdot \frac{a - bi}{a - bi} = \frac{a}{a^2 + b^2} + \frac{-b}{a^2 + b^2}i.$$

Doing this, we have

$$\begin{aligned} & \operatorname{Re} \left\{ \frac{V_0}{R - i\frac{1}{\omega C}} e^{i\omega t} \right\} \\ &= \operatorname{Re} \left\{ V_0 \left[\frac{R}{R^2 + (1/\omega C)^2} + \frac{1/\omega C}{R^2 + (1/\omega C)^2} i \right] \left[\cos(\omega t) + i \sin(\omega t) \right] \right\} \\ &= \frac{V_0}{R^2 + (1/\omega C)^2} \left[R \cos(\omega t) - \frac{1}{\omega C} \sin(\omega t) \right] \end{aligned}$$

and

$$\begin{aligned} & \operatorname{Re} \left\{ \frac{V_0}{R + i\omega L} e^{i\omega t} \right\} \\ &= \operatorname{Re} \left\{ V_0 \left[\frac{R}{R^2 + (\omega L)^2} - \frac{\omega L}{R^2 + (\omega L)^2} i \right] \left[\cos(\omega t) + i \sin(\omega t) \right] \right\} \\ &= \frac{V_0}{R^2 + (\omega L)^2} [R \cos(\omega t) + \omega L \sin(\omega t)]. \end{aligned}$$

So we have

$$\begin{aligned} I_1 &= \frac{V_0}{R^2 + (1/\omega C)^2} \left[R \cos(\omega t) - \frac{1}{\omega C} \sin(\omega t) \right], \\ I_2 &= \frac{V_0}{R^2 + (\omega L)^2} [R \cos(\omega t) + \omega L \sin(\omega t)]. \end{aligned}$$

In this form, it is not obvious what the maximum value of the currents would be. However, with the help of a trigonometric identity we can get the expressions for the currents into a form in which the maximum values are apparent, that identity being

$$a \cos(x) + b \sin(x) = \sqrt{a^2 + b^2} \cos \left\{ x - \tan^{-1} \left(\frac{b}{a} \right) \right\}.$$

Through an application of this identity, the expressions for the currents become

$$\begin{aligned} I_1 &= \frac{V_0}{\sqrt{R^2 + \left(\frac{1}{\omega C}\right)^2}} \cos(\omega t + \tan^{-1}(1/\omega RC)), \\ I_2 &= \frac{V_0}{\sqrt{R^2 + (\omega L)^2}} \cos(\omega t - \tan^{-1}(\omega L/R)), \end{aligned}$$

where the relation $\tan^{-1}(-x) = -\tan^{-1}(x)$ is used. It follows that I_1 and I_2 are sinusoidal currents with squared maximum values $I_{0,1}^2$ and $I_{0,2}^2$ given by

$$I_{0,1}^2 = \frac{V_0^2}{R^2 + \left(\frac{1}{\omega C}\right)^2},$$

$$I_{0,2}^2 = \frac{V_0^2}{R^2 + (\omega L)^2}.$$

The reason for squaring the magnitudes of the currents is that that corresponds to the quantities that the D'Arsonval current meter responds, the needle deflection being proportional to the average of the squared current.

Now we consider the special frequency $\omega = 1/\sqrt{LC}$ at which $I_{0,1}^2$ and $I_{0,2}^2$ become equal, i.e.,

$$I_{0,1}^2 = I_{0,2}^2 = \frac{V_0^2}{R^2 + \frac{L}{C}}.$$

At that frequency we also have

$$I = I_1 + I_2 = \frac{V_0}{\sqrt{R^2 + \frac{L}{C}}} \cos \left\{ \omega t + \tan^{-1} \left(\frac{1}{R} \sqrt{\frac{L}{C}} \right) \right\}$$

$$+ \frac{V_0}{\sqrt{R^2 + \frac{L}{C}}} \cos \left\{ \omega t - \tan^{-1} \left(\frac{1}{R} \sqrt{\frac{L}{C}} \right) \right\}$$

An application of the trigonometric identities

$$\cos(a) \cos(b) = \frac{1}{2} (\cos(a+b) + \cos(a-b))$$

and

$$\cos(\tan^{-1}(x)) = \frac{1}{\sqrt{1+x^2}}$$

yields

$$I = \frac{2V_0}{\sqrt{R^2 + \frac{L}{C}}} \cos(\omega t) \cos \left\{ \tan^{-1} \left(\frac{1}{R} \sqrt{\frac{L}{C}} \right) \right\}$$

$$= \frac{2V_0}{\sqrt{R^2 + \frac{L}{C}}} \cdot \frac{1}{\sqrt{1 + \frac{L}{R^2 C}}} \cos(\omega t).$$

Therefore the squared maximum value of the current I , denoted I_0^2 , is

$$I_0^2 = \frac{4V_0^2}{\left(R^2 + \frac{L}{C}\right) \left(1 + \frac{L}{R^2C}\right)}.$$

Comparing that with the expressions

$$I_{0,1}^2 = I_{0,2}^2 = \frac{V_0^2}{R^2 + \frac{L}{C}}$$

we see that $I_0^2 < I_{0,1}^2 = I_{0,2}^2$ when $L/(R^2C) > 3$ and $\omega = 1/\sqrt{LC}$. Under such conditions meter M will measure a smaller current than either of the meters M_1 or M_2 , even though the splitting of the current I forms currents I_1 and I_2 . [probability theory](#) ■

It took many years for the engineering community to feel comfortable with counterintuitive results such as this, which explains why AC circuits were long thought to be somehow different from DC circuits. All circuits obey the same physical laws, however, and an important milestone in understanding the role of complex quantities was passed in 1893, when Charles Steinmetz presented a paper at the International Electrical Congress in Chicago titled "Complex Quantities and Their Use in Electrical Engineering." His paper was introduced to the audience with the following words:

We are coming more and more to use these complex quantities instead of using sines and cosines, and we find great advantage in their use for calculating all problems of alternating currents, and throughout the whole range of physics. Anything that is done in this line is of great advantage to science.

To the extent that numbers exist, $\sqrt{-1}$ exists, though it does not represent a calculable quantity. Of the other common types of numbers, say, out of the set $\{\mathbb{Z}, \mathbb{Q}, \mathbb{R}, \mathbb{C}\}$ of familiar number systems, that have representations suggestive of calculation are the rationals, \mathbb{Q} ; numbers such as $2/3$. But they, in contrast, can be calculated, due to our acceptance of the real number system, \mathbb{R} . Just as with the symbol "7", the only valid question is how do we calculate *with* the symbol $\sqrt{-1}$, rather than how we calculate the symbol itself, as we could with a rational.

The symbol i is *not* "the number we would get if it were possible to take the square root of -1 ", because that *is* impossible, yet we *have* the number. Rather, by definition, $i \equiv \sqrt{-1}$, and it behaves so. [game theory](#)

To avoid confusion, it should be mentioned that -1 actually has two square roots, namely $\pm i$, and that it *is* possible to calculate the square root of a complex number, just not the square root of -1 . In particular, through an application of Euler's formula, it is easily shown that i itself does have a square root, in fact two square roots, namely, either of the two complex numbers

$$\pm\sqrt{i} = \pm e^{i\pi/4} = \pm \left(\cos \frac{\pi}{4} + i \sin \frac{\pi}{4} \right) = \pm \left(\frac{\sqrt{2}}{2} + \frac{\sqrt{2}}{2}i \right)$$

Mathematicians tend to think of a complex number $a + bi$, where a and b are real numbers and $i = \sqrt{-1}$, as a point in the *complex plane*, a plane in which the value of a corresponds to placement of the point along the horizontal x -axis and the value of b corresponds to placement of the point along the vertical y -axis. The x -axis is known as the real axis, while the y -axis is known as the imaginary axis, and are usually labelled Re and Im respectively. Unlike the real numbers, complex numbers do not have a natural ordering, so there is no complex-valued analog of real inequalities. This property is no longer confusing when they are viewed as being elements in the complex plane, since points in any plane lack a natural ordering. The term *natural ordering* refers to ordering along a line. Most points within any plane are not mutually collinear.

Complex numbers possess many properties the reals do not possess, properties such as *phase*. If we were to draw a vector from the origin to the complex number's point in \mathbb{C} , then what angle would the vector make with the positive x -axis? Now if we were to trace out a circle with that same vector, then all the complex numbers residing on it would have the same distance from the origin, known as the complex number's *absolute value* or *modulus*. So there are an infinite number of complex values having the same "magnitude" in a sense, but each has a different phase. One must be careful with the concept of magnitude in \mathbb{C} ; magnitude does not correspond to order within \mathbb{C} as it does within the real number system \mathbb{R} . There is more to complex numbers than just raw magnitude. It can

be helpful to realize that a complex number's phase also carries its own "magnitude". Complex numbers can be considered to be ordered in two ways – concentrically and rotationally, so they are described as having no *natural order*, in other words, like that of the natural numbers. To be precise, it would be incorrect to say that the complex numbers "have no order", for that would imply they are distributed randomly in common mathematical parlance, which is nonsense.

Despite the initial awkwardness, the successes achieved through the use of complex numbers have exceeded all expectations. The successes helped gain their full recognition, with no small thanks due to the representation of complex numbers as points on a plane, which enabled mathematicians to visualize them in a natural way. [desktop computers](#)

Chapter 2

Del Ferro, Tartaglia, Cardano & Bombelli

We begin with the work of a character named Scipione del Ferro (1465-1526) who taught at the University of Bologna. Del Ferro is most famous for discovering a formula for solving a *depressed cubic* – a third-degree equation that lacks a quadratic term, in other words, one of the form $ax^3 + cx + d = 0$. For presentation, we usually divide through the entire equation by a and move the constant term to the right-hand side, to get the form

$$x^3 + mx = n.$$

At the time, del Ferro's discovery of how to solve a depressed cubic for x was quite significant, and by today's customs, we might expect him to have shouted his findings off the rooftops. But he kept the solution secret. Why? The political climate of Renaissance universities was perilous. Academics often had to patronize the politically powerful – da Vinci's experience being a very famous example. But there is more. The concept of tenure hadn't even been thought of yet, nor did society have safety nets in those days. On top of this, mathematicians had to be ready for "public challenges", which were basically intellectual duels. Participation in challenges were strongly encouraged by the university community, and these often became wild events even attracting the attention of large gambling rings. A loss often marked the end of one's career. So, quite understandably, del Ferro felt that he was in possession of a secret weapon, and he treated his discovery so. Even if del Ferro could not solve his challenger's problems, he was highly confident that his cubics would not be solved by his adversary.

On his deathbed, del Ferro passed his discovery along to his student Antonio Fior. A brash and arrogant young lad, Fior decided to go on an intellectual spree with the new weapon, and eventually by 1535 became testy with one of the greatest minds in Europe, the famous scholar Niccolo Fontana (1499-1557), whom Fior mistakenly presumed to be a pretender to the throne.

During the French attack on Fontana's hometown of Brescia in 1512, a soldier slashed Fontana's face with a sword, disfiguring him and making it impossible for him to speak normally. He became known by a nickname, Tartaglia, which means stammerer, and by this name is he best known even today. [laptop computers](#)

Tartaglia was a profoundly-gifted mathematician. He had been advertising the fact that he could solve cubic equations missing only their linear terms, which was what attracted the attention and the doubts of Fior. Fior sent him a challenge consisting of thirty depressed cubics, to which Tartaglia wisely responded, by sending Fior a list of thirty problems covering various difficult mathematical topics. Tartaglia was either going to earn a perfect performance or completely fail, depending on whether or not he found the secret of solving cubics.

Tartaglia went on a research binge. And with the deadline approaching, on February 13, 1535, he discovered the depressed cubic's solution. He then quickly solved all of Fior's problems, whereas Fior suffered a miserable performance. It was a great triumph for Tartaglia. Although the agreed-upon stake was to provide thirty banquets for the victor, Tartaglia decided to relieve Fior of the burden, who then faded out of the picture.

One of the most eccentric mathematicians in history enters the story at this point, Gerolamo Cardano (1501-1576), of Milan. Cardano had heard of the challenge and desired to learn Tartaglia's method for solving the cubic. He simply asked Tartaglia to divulge the secret, and from there the story takes a few twists. [cell phones on sale](#)

There is just "that something" about the intriguing lives of eccentric geniuses that cannot be ignored, so we pause and examine some of Cardano's



Figure 2.1: Portraits of the great mathematicians (from left to right) Niccolo Fontana Tartaglia, Gerolamo Cardano and Rafael Bombelli.

curious life first. Lucky for us, Cardano wrote an autobiography *The Book of My Life* in 1575, the year before he died. The book recounts many of Cardano's superstitions, peevs and personal anecdotes. Though some of the material is regarded with a degree of skepticism, the book nonetheless conveys Cardano's frame of mind and turbulent life.

Cardano's family tree is as eventful as his own life, and may have included Pope Celestino IV. In the chapter titled "My Nativity", Cardano wrote "although various abortive medicines – as [he] heard – were tried in vain," he survived to be "literally torn from [his] mother's womb." The young Cardano was then bathed in warm wine in an effort to bring him to life. Cardano perceived his birth as unwelcome, and may have been illegitimate. The resulting stigma he felt played a powerful role in his life.

Cardano was plagued with chronic mental conditions his entire life, yet his intellect was supreme, as is evident in his works. He had an intense fear of heights, and of places where rabid dogs had been seen. He endured years of impotence, which, as fate would have it, lasted until just before he was married. Cardano also suffered from bouts of insomnia, often staying awake for more than a week at a time. [diamond jewelry](#)

If Cardano found himself on occasion to not be suffering, then he would inflict suffering upon himself. Cardano equated pleasure with the relief of pain. He felt that self-inflicted pain was a very desirable thing, because it felt good when the pain stopped.

Cardano studied at the University of Padua to become a physician, but was refused permission to practice medicine in his home of Milan. This refusal was probably due to his bizarre personality, but whatever the justification was, this event marked one of the lowest points of his life.

Cardano then moved to the rural town of Sacco, where he practiced medicine. One night, he dreamt of a beautiful woman and, being one who put a great deal of stock in dreams, after having met a woman named Lucia Bandarini who resembled the woman in his dream, he married her in 1531.

Dreams and omens guided Cardano throughout his life. He was an astrologer, wore amulets and claimed to predict the future from thunderstorms. He also felt the presence of a guardian angel, and would participate in detailed conversations and at times even argue with the divine attendant, out loud in front of his colleagues. That being the case, it is no wonder why many of his contemporaries felt that Cardano was not in his right mind. [watches](#)

Cardano was a prolific gambler, he had a weakness for it, gambling nearly every day. His work *Book on Games of Chance*, published posthumously in 1663, was the first serious treatise on probability.

From 1526 to 1532, Cardano spent busy years in Sacco, practicing medicine and raising his children, but eventually moved with his wife and kids back to Milan for reasons related to his ego, yet ironically, was still forbidden to practice medicine there, which left them poor. But Cardano began giving popular science lectures that were well received by the educated. He began writing on many topics and in particular, in 1536 wrote a scathing work attacking the practices of Italian physicians. Though the medical community detested this work, the public embraced it, and Cardano could not safely be prevented from practicing medicine any longer. He went to the top of his profession, even treating the Pope on occasion.

But then a series of tragedies befell Cardano. In 1546, his wife died at age 31, leaving Cardano with two sons and one daughter. Yet much to Cardano's delight, his eldest son, Giambattista, seemed bright and destined to follow in his father's footsteps into a brilliant medical career. But Giambattista married an unfaithful woman who boasted about the town that none of her three children were his. In retaliation, Giambattista presented her with a cake laced with arsenic. Apparently, he was a good baker – Giambattista was arrested for murder, he confessed and was convicted, then beheaded by the Roman Empire during April 1560.

Cardano became despondent, and lost his interest in life, followed by his friends and career. He then moved to the University of Bologna to teach medicine. In 1570, he got himself arrested and imprisoned on charges of heresy, for antics such as publishing his results of casting the horoscope of Christ and writing a book titled *In Praise of Nero*, the Roman Emperor that offered Christians to the Colosseum animals as food, sentencing them *ad bestias*, "to the beasts" – the beasts in question included dogs, bears, boars and lions. However, on the part of friend's testimony and some leniency granted by the Church, Cardano was released from prison, went to Rome, and eventually was given a pension from Pope Gregory XIII (after first having been rejected by Pope Pius V). [thermodynamics](#)

Cardano died in Rome on September 20, 1576, the day he had (supposedly) astrologically predicted earlier; but some suspect that he may have committed suicide so that his own "prophesied" date of death would manifest true.

Now let's return to the story of the cubic equation. Cardano was interested in the techniques Tartaglia used to defeat Fior. Cardano had written to Tartaglia many times, pleading with him for the solution. Eventually, Cardano brought Tartaglia to Milan as a guest. On March 25, 1539, Tartaglia revealed the secret of the depressed cubic – written in cipher – to Cardano, who took an oath of secrecy based upon his Christian faith which, if violated, would essentially result in eternal damnation to the flames of Hell, according to the beliefs of those times.

Another character then appears in this epic. Ludovico Ferrari (1522-1565),

approached Cardano looking for work. Cardano had that day imagined that the squawking of a magpie was a good omen and thus hired the young man as an assistant. But, as fate would have it, Ferrari amazingly turned out to be at least as profoundly gifted as Tartaglia, and even before Ferrari was 20 years old, Cardano considered him a colleague. Cardano eventually shared Tartaglia's secret with his protégé, and they made great strides together.

For example, Cardano discovered how to solve the general cubic equation

$$x^3 + bx^2 + cx + d = 0$$

where the coefficients b , c and d may or may not be zero. But Cardano's work depended upon reducing the general cubic to a depressed form, thus publication would violate his pledge of secrecy to Tartaglia. Ferrari had meanwhile succeeded in solving the quartic (fourth degree) polynomial. Ferrari's technique depended upon reducing the quartic to a related cubic, and again Cardano's pledge forbade its publication. [bioinformatics](#)

But in 1543, Cardano and Ferrari traveled to Bologna where they inspected the papers of del Ferro. There, in del Ferro's own handwriting, was the technique for solving the depressed cubic. The fact that Tartaglia's and del Ferro's solutions were identical did not bother Cardano, del Ferro's work having preceeded Tartaglia's work. So in the year 1545, Cardano published *Ars Magna*, a title which reflects Cardano's belief that algebra was "the great art". *Ars Magna* began with some introductory material, including standard solutions to linear and quadratic equations. But then it jumped into uncharted territory and laid out for the first time a complete procedure for solving cubic and biquadratic (third- and fourth-degree) algebraic equations. It was not until the arrival of mathematicians at the level of François Viète (1540-1603) and René Descartes (1596-1650) that the book's contributions were superseded.

In Chapter XI, titles "On the Cube and First Power Equal to the Number," the preface reads:

Scipio Ferro of Bologna well-nigh thirty years ago discovered this rule and handed it on to Antonio Maria Fior of Venice, whose contest with Niccolo Tartaglia of Brescia gave Niccolo occasion to discover it. He gave it to me in response to my entreaties, though withholding the demonstration. Armed with this assistance, I sought out its demonstration in many forms. This was very difficult.

Cardano had merely given credit where credit was due, which appeased everyone except Tartaglia. He considered Cardano's act treachery. In Tartaglia's eyes, Cardano violated an oath pledged on his Christian faith, and was, therefore, a heathen. Cardano refused to respond to Tartaglia's vitriolic letters, but Ferrari gave in to his legendary hot temper, and lashed back with demeaning threats, such as "If it were up to me to reward you, . . . , I would load you up so much with roots and radishes, that you would never eat anything else in your life", all pun intended. Eventually, a challenge was exchanged between Tartaglia and Ferrari, in Milan in August of 1548. Ferrari won the battle and Tartaglia withdrew to return home, probably lucky to leave with his life. [nuclear physics](#)

Such were the absurd set of events surrounding the solution of the cubic. Now we consider the great theorem at the heart of all this drama.

In Chapter XI of *Ars Magna*, Cardano did not give a general proof, but rather a specific example of a depressed cubic, namely

$$x^3 + 6x = 20.$$

But in our discussion, we shall paraphrase his work and treat the more general depressed cubic

$$x^3 + mx = n.$$

Before getting into the specifics of Cardano's technique, a few points are worth mentioning. The material on cubic equations first appears in Chapter XI of the *Ars Magna*, which, as we stated previously, is titled "On the Cube and First Power Equal to the Number." From the perspective inherited from medieval mathematicians, there were considered to be 3 different depressed cubics and 13 different general cubics, rather than just one of each. This is because they only considered positive real numbers; they did

not admit complex numbers, nor did they consider nonpositive coefficients. The rule Tartaglia gave Cardano covered the three basic forms of the depressed cubic. In modern form, these would be: $x^3 + bx = c$, $x^3 = bx + c$ and $x^3 + c = bx$. Since mathematicians at the time did not use negative coefficients, a single, general form $x^3 + bx + c = 0$ was precluded.

In addition, our modern algebraic notation still lay in the future, and most of the mathematical statements were verbal. Cardano could capture generality in the rules for solving the pseudo-general cubic equations. In each chapter, then, Cardano first gives a geometrical demonstration of a specific numerical cubic equation, then a verbal rule for solving that general type of equation, then one or more sample problems and solutions using the rule. Because the use of zero and negative coefficients still lay in the future, Cardano is forced into spelling out 13 different cubic equations, all with positive coefficients, each with a separate chapter.

Now, we can write a general cubic equation

$$py^3 + qy^2 + ry + s = 0$$

(in which $p \neq 0$, or the equation is not a cubic) in the form

$$y^3 + by^2 + cy + d = 0$$

after dividing by the constant p . The case where $d = 0$ is trivial and not considered a true cubic.

So, initially we get different cases as

$$b \begin{matrix} > \\ < \end{matrix} 0, \quad c \begin{matrix} > \\ < \end{matrix} 0, \quad d \begin{matrix} > \\ < \end{matrix} 0$$

leading to $3 \cdot 3 \cdot 2 = 18$ cases initially. Note that here we should interpret $>$ and $<$ in medieval terms, that is, indicators that the coefficient occurs on the left or right side of the equation, respectively.

However, the cases

$$\begin{aligned} b = c = 0, & \quad d > 0 \\ b = c = 0, & \quad d < 0 \end{aligned}$$

were not taken seriously as cubic equations (the first has no positive real solution and the second is trivial), while the cases

$$\begin{aligned} b > 0, \quad c > 0, \quad d > 0 \\ b = 0, \quad c > 0, \quad d > 0 \\ b > 0, \quad c = 0, \quad d > 0 \end{aligned}$$

also have no real positive solutions. This leaves $18 - 5 = 13$ cases to be considered.

The key result of Chapter XI of *Ars Magna* is stated here in Cardano's own manner, and his extremely clever partitioning of the cube is presented. The rule for solving cubics, as presented, is wordy and confusing, but the reader will come to a better understanding when it is recast in more familiar algebraic terms.

As William Dunham puts it in his fascinating book *Journey Through Genius*, "His argument was purely geometrical, involving literal cubes and their volumes. Actually, the surprise here is minimized when we recall the primitive state of algebraic symbolism and exalted position of Greek geometry among Renaissance mathematicians."

Theorem 2.1. Rule to solve $x^3 + mx = n$.

Cube one-third the coefficient of x ; add to it the square of one-half the constant of the equation; and take the square root of the whole. You will duplicate this, and to one of the two you add one-half the number you have already squared and from the other you subtract one-half the same. Then, subtracting the cube root of the first from the cube root of the second, the remainder which is left is x .

Proof. Cardano pictured a large cube, of side AC, whose length we denote by t , as shown in Figure 2.2. Side AC is divided at B into segment BC of length u and segment AB of length $t - u$. The large cube can be mentally subdivided into six pieces (use Figure 2.2 as a guide), and each piece is identified and assigned a volume as indicated:

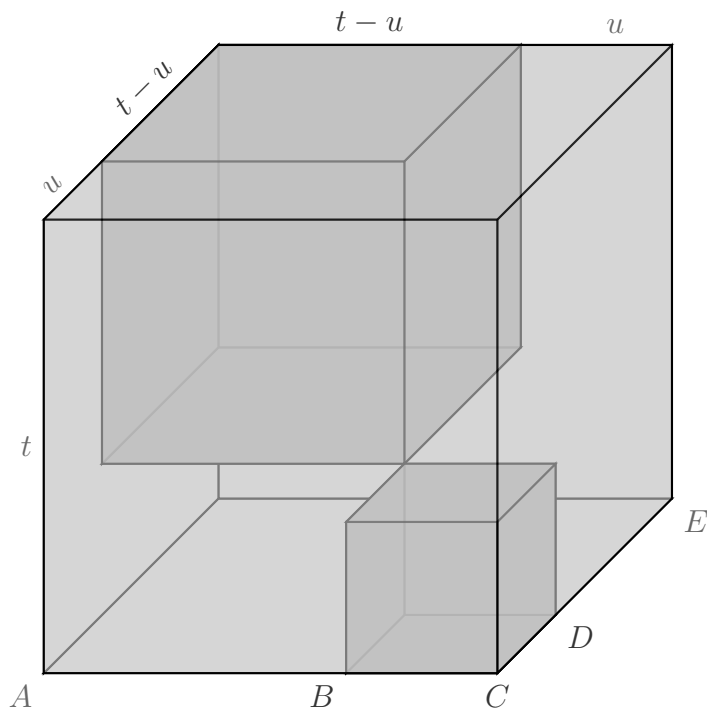

Figure 2.2: Cardano's partitioned cube.

- A small cube in the lower front corner of volume u^3 .
- A larger cube in the upper back corner of volume $(t - u)^3$.
- Two upright slabs, one facing front along AB and the other facing right along DE, each of volume $tu(t - u)$.
- A tall block in the upper front corner, standing upon the small cube, of volume $u^2(t - u)$.
- A flat block in the lower back corner, beneath the larger cube, of volume $u(t - u)^2$.

Certainly the large cube's volume, t^3 , equals the sum of these six component volumes. That is,

$$t^3 = u^3 + (t - u)^3 + 2tu(t - u) + u^2(t - u) + u(t - u)^2.$$

A slight rearrangement of terms gives

$$(t - u)^3 + [2tu(t - u) + u^2(t - u) + u(t - u)^2] = t^3 - u^3$$

and factoring the common $(t - u)$ term from the bracketed expression yields

$$(t - u)^3 + (t - u)[2tu + u^2 + u(t - u)] = t^3 - u^3.$$

Or simply,

$$(t - u)^3 + 3tu(t - u) = t^3 - u^3. \quad (2.1)$$

Now, Equation 2.1 resembles the cubic $x^3 + mx = n$. If we let $t - u = x$, then it becomes $x^3 + 3tux = t^3 - u^3$, and this immediately suggests that we set

$$3tu = m \quad \text{and} \quad t^3 - u^3 = n.$$

If we can determine the values of t and u in terms of m and n from the original cubic, then $x = t - u$ will yield the solution. To start, consider the two previous equations involving t and u , namely

$$3tu = m \quad \text{and} \quad t^3 - u^3 = n.$$

From the first equation, we see that $u = m/3t$, and substituting this into the second equation gives

$$t^3 - \frac{m^3}{27t^3} = n.$$

And now the *key step* – multiply both sides by t^3 and rearrange to get

$$t^6 - nt^3 - \frac{m^3}{27} = 0.$$

At first glance, this might seem to be a step backwards, trading the third-degree equation in x for a sixth-degree equation in t . But the later can be regarded as a quadratic equation in t^3 ,

$$(t^3)^2 - n(t^3) - \frac{m^3}{27} = 0.$$

An application of the quadratic formula, which had been in use since Babylonian times, then yielded

$$\begin{aligned}
 t^3 &= \frac{n \pm \sqrt{n^2 + \frac{4m^3}{27}}}{2} \\
 &= \frac{n}{2} \pm \frac{1}{2} \sqrt{n^2 + \frac{4m^3}{27}} = \frac{n}{2} \pm \sqrt{\frac{n^2}{4} + \frac{m^3}{27}}.
 \end{aligned}$$

Then, retaining only the positive square root, we arrive at

$$t = \sqrt[3]{\frac{n}{2} + \sqrt{\frac{n^2}{4} + \frac{m^3}{27}}}.$$

And since $u^3 = t^3 - n$, we naturally conclude that

$$\begin{aligned}
 u^3 &= \frac{n}{2} + \sqrt{\frac{n^2}{4} + \frac{m^3}{27}} - n \quad \text{or} \\
 u &= \sqrt[3]{-\frac{n}{2} + \sqrt{\frac{n^2}{4} + \frac{m^3}{27}}}.
 \end{aligned}$$

So the algebraic statement of Cardano's rule for solving the depressed cubic $x^3 + mx = n$ is

$$\begin{aligned}
 x &= t - u \\
 &= \sqrt[3]{\frac{n}{2} + \sqrt{\frac{n^2}{4} + \frac{m^3}{27}}} - \sqrt[3]{-\frac{n}{2} + \sqrt{\frac{n^2}{4} + \frac{m^3}{27}}}.
 \end{aligned}$$

□

This formula is called an "algebraic solution" or a "solution by radicals" for the depressed cubic. Solutions of this type involve only the original coefficients of the depressed cubic – m and n – and algebraic operations, used only a finite number of times. It gives exactly the same result as Cardano's verbally-stated rule.

Cardano's approach in the proof of the previous theorem may leave one feeling bewildered. Though his generation was far more practiced at geometrical thinking than ours, how and why would he even imagine to relate

the initial 6-partitioning of a literal cube to this particular algebraic problem? A statement made by the famous Polish-American mathematician Mark Kac (1914-1984) relates to this question – his famous distinction between the ordinary genius and the magician genius: "An ordinary genius is a fellow that you and I would be just as good as, if we were only many times better. There is no mystery as to how his mind works. Once we understand what he has done, we feel certain that we, too, could have done it. It is different with the magicians . . . the working of their minds is for all intents and purposes incomprehensible. Even after we understand what they have done, the process by which they have done it is completely dark." Cardano's proof is magical. Taking much for granted, his proof reads straightforward, but the initial idea, the partitioning of a literal cube, is not at all obviously related to the objective.

But, from a modern perspective, the key insight in his derivation was to transform the cubic problem into a quadratic problem. This simple, yet brilliant step is suggestive of a method for solving equations of even higher degrees. However, note that in algebra, the Abel-Ruffini theorem (also known as Abel's impossibility theorem) states that there is no general algebraic solution – that is, solution in radicals – to polynomial equations of degree five or higher.

The content of the Abel-Ruffini theorem is frequently misunderstood. The theorem only concerns the form that such a solution must take. It does not assert that higher-degree polynomial equations are unsolvable. In fact, the opposite is true: every non-constant polynomial equation in one unknown, with real or complex coefficients, has at least one complex number as solution; this is the fundamental theorem of algebra, which can also be stated equivalently as: every non-zero single-variable polynomial with complex coefficients has exactly as many complex roots as its degree, if each root is counted up to its multiplicity. The reader should note that in these definitions, the complex numbers \mathbb{C} are considered to include the real numbers \mathbb{R} as a subset, so by the phrase "complex number" we do not necessarily mean "purely imaginary number", which is a complex number with real part precisely equal to zero, nor do we necessarily exclude the pure reals.

Although the solutions cannot always be expressed exactly with radicals, they can be computed to any desired degree of accuracy using numerical methods such as the Newton-Raphson method or Laguerre method, and in this way they are no different from solutions to second, third or fourth degree polynomials.

Simply plugging appropriate values into the algebraic equation allows us to easily find a solution for Cardano's example $x^3 + 6x = 20$,

$$x = \sqrt[3]{10 + \sqrt{108}} - \sqrt[3]{-10 + \sqrt{108}}$$

which is obviously a "solution by radicals" as the saying goes.

Surprisingly, this complicated expression is equivalent to the number 2, as one may check through calculation. Also, as the reader may easily check, $x = 2$ is indeed a solution of $x^3 + 6x = 20$.

Now, having found one solution to the cubic, we are actually in a position to find any others. Since $x = 2$ solves the above equation, we know that $x - 2$ is a factor of $x^3 + 6x - 20$. Long division will generate the other. In this case, we have $x^3 + 6x - 20 = (x - 2)(x^2 + 2x + 10)$. The solutions to the original cubic can be obtained by solving

$$x - 2 = 0 \quad \text{and} \quad x^2 + 2x + 10 = 0.$$

The quadratic equation above has no real solutions, so the cubic has $x = 2$ as its only real solution.

What about the general cubic of the form $ax^3 + bx^2 + cx + d = 0$? Cardano could solve the depressed cubic, but ultimately, despite Cardano's brilliant restatement of the method, it was del Ferro's discovery how to do so. Cardano himself made the great discovery that, by means of an appropriate substitution, the general equation could be replaced by a related depressed cubic that was susceptible to solution. Overall, the process looks like this:

1. Depress the cubic: Achieved by substituting into the original cubic an appropriate substitution formula in a new variable, say y . (Cardano)
2. Solve the depressed cubic: Find y in terms of the depressed cubic's variables, say m and n . (del Ferro)

3. Recover the value of the original general cubic's variable, say x , in terms of y , using the substitution formula. (Cardano)

Before we demonstrate the depressing process for the cubic, it is instructive to see the effect of applying it to quadratic equations. Suppose we have a general second-degree equation

$$ax^2 + bx + c = 0 \quad \text{where } a \neq 0.$$

To depress the quadratic – that is, to eliminate its first-power term – we substitute $x = y - b/2a$, which leads to

$$\begin{aligned} a \left(y - \frac{b}{2a} \right)^2 + b \left(y - \frac{b}{2a} \right) + c &= 0, \\ a \left(y^2 - \frac{b}{a}y + \frac{b^2}{4a^2} \right) + by - \frac{b^2}{2a} + c &= 0, \\ ay^2 - by + \frac{b^2}{4a} + by - \frac{b^2}{2a} + c &= 0. \end{aligned}$$

After cancellation, then by rearranging, we arrive at the depressed quadratic

$$ay^2 = \frac{b^2}{2a} - \frac{b^2}{4a} - c = \frac{b^2 - 4ac}{4a}.$$

We have

$$y^2 = \frac{b^2 - 4ac}{4a^2} \quad \text{and} \quad y = \frac{\pm\sqrt{b^2 - 4ac}}{2a}.$$

And as a final step we calculate,

$$x = y - \frac{b}{2a} = \frac{\pm\sqrt{b^2 - 4ac}}{2a} - \frac{b}{2a} = \frac{-b \pm \sqrt{b^2 - 4ac}}{2a}$$

which is the familiar quadratic formula.

So, we see that depressing polynomials can be rather useful. Now let's attack the general cubic. In this case, the appropriate substitution turns out to be $x = y - b/3a$, giving us

$$a \left(y - \frac{b}{3a} \right)^3 + b \left(y - \frac{b}{3a} \right)^2 + c \left(y - \frac{b}{3a} \right) + d = 0.$$

Simply expand this to get

$$\begin{aligned} \left(ay^3 - by^2 + \frac{b^2}{3a}y - \frac{b^3}{27a^2} \right) + \left(by^2 - \frac{2b^2}{3a}y + \frac{b^3}{9a^2} \right) \\ + \left(cy - \frac{cb}{3a} \right) + d = 0. \end{aligned}$$

All we have to do here is make a single key observation: the y^2 terms will cancel out. The new depressed cubic will lack a second-degree term as desired. Now, if we divide through by a , the resulting equation will of course take the form $y^3 + py = q$. We solve this as before, and from there easily determine $x = y - b/3a$.

As an example, consider the cubic

$$2x^3 - 30x^2 + 162x - 350 = 0.$$

Using the substitution $x = y - b/3a = y - (-30/6) = y + 5$, we have

$$2(y + 5)^3 - 30(y + 5)^2 + 162(y + 5) - 350 = 0,$$

which when simplified becomes

$$2y^3 + 12y - 40 = 0 \quad \text{or simply} \quad y^3 + 6y = 20.$$

But this is the depressed cubic solved earlier, so we know $y = 2$. So we find $x = y + 5 = 7$, and this checks in the original cubic equation.

This seems to have brought matters to a conclusion. The cubic had been solved. But wait! Cardano's formula introduced something mysterious.

Consider the depressed cubic $x^3 - 15x = 4$, for example. Inserting the values $m = -15$ and $n = 4$ into Cardano's formula, we get

$$x = \sqrt[3]{2 + \sqrt{-121}} - \sqrt[3]{-2 + \sqrt{-121}}.$$

Mathematicians were hardly comfortable with negative numbers in the sixteenth century. This had much to do with the strong emphasis on geometric thinking – there is no such thing as a negative amount of distance

in classical geometry. So the square roots of negative numbers seemed absolutely preposterous to them. Thus, it was natural for them to dismiss an example such as this as an "unsolvable cubic". However, the cubic above has three different and purely real solutions: $x = 4$ and $x = -2 \pm \sqrt{3}$.

What were mathematicians to make of these cases? Though he did spend some time on the subject, Cardano ultimately dismissed the business of complex numbers as being "as subtle as it is useless."

It would be many years before Rafael Bombelli (1526-1573), in his 1572 treatise *Algebra*, asserted the necessity of complex numbers as a vehicle to transport the mathematician from the real cubic to its real solutions. In certain cases, though we begin and end in the familiar terrain of real numbers, complex numbers are absolutely necessary to complete the journey.

Let's examine briefly Bombelli's work. We cube the complex number $2 + \sqrt{-1}$ to get

$$\begin{aligned}(2 + \sqrt{-1})^3 &= 8 + 12\sqrt{-1} - 6 - \sqrt{-1} \\ &= 2 + 11\sqrt{-1} = 2 + \sqrt{-121}.\end{aligned}$$

But if $(2 + \sqrt{-1})^3 = 2 + \sqrt{-121}$, then it certainly follows that

$$\sqrt[3]{2 + \sqrt{-121}} = 2 + \sqrt{-1}. \quad (2.2)$$

In a similar way, we can also see that

$$\sqrt[3]{-2 + \sqrt{-121}} = -2 + \sqrt{-1}.$$

Concerning the cubic $x^3 - 15x = 4$, Bombelli arrived at

$$\begin{aligned}x &= \sqrt[3]{2 + \sqrt{-121}} - \sqrt[3]{-2 + \sqrt{-121}} \\ &= (2 + \sqrt{-1}) - (-2 + \sqrt{-1}) = 4\end{aligned}$$

which is one of the correct answers.

Bombelli's observation raises more questions than it answers. How does one know the truth of Equation 2.2 beforehand? Bombelli was essentially

walking "backwards" into the problem. The world would have to wait until the middle of the eighteenth century for Leonhard Euler to discover a sure-fire technique for finding roots of complex numbers (in a "forward" direction). And what exactly are these complex numbers, and how were they different than real numbers? The full scope of the importance of complex numbers was not realized until the work of Euler, Gauss and Cauchy, over two centuries after Bombelli's work.

The work of del Ferro and Cardano created a need for the recognition of complex numbers, whereas Bombelli was the first to actually give that recognition. Bombelli was the first to teach the art of correct formal computation with complex numbers.

Now, a few things need explicit mentioning here. Contrary to popular belief, or what may seem to be implied in some textbooks, complex numbers did **not** enter the realm of mathematics out of a need to solve quadratics. Complex numbers entered as a tool for solving cubics. Mathematicians could more easily dismiss $\sqrt{-121}$ when it appeared as a solution to $x^2 + 121 = 0$, which has no real solutions. But they could not so easily dismiss $\sqrt{-121}$ when it played such a key role in arriving at the solution $x = 4$ for the previous cubic. It was the relation of complex numbers to cubics, not quadratics, that made complex numbers interesting, which eventually led to their legitimization.

Nevertheless, the fact that $\sqrt{-1}$ is a solution to $x^2 + 1 = 0$ does give a perfectly valid illustration of the utility of complex numbers, and the mythology concerning the role of the quadratics might be preferable in some situations, in terms of expedience. In the rest of this work, we usually adhere to this mythology, for that very reason.

Also note the following nuance in nomenclature. Cardano's name is usually spelled Cardan in the English language. We shall forgive the minor alteration and use the name Cardan in the rest of this book, for no other reason but consistency with the greater part of the mathematical literature.

Chapter 3

The Complex Field

In the 16th century, Cardan reluctantly worked with complex numbers in solving quadratic and cubic equations. Later in the 18th century, functions involving $\sqrt{-1}$ were found by Euler that were solutions to differential equations. In a letter dated October 18, 1740 to John Bernoulli, Euler wrote that the solution to the differential equation

$$\frac{d^2y}{dx^2} + y = 0, \quad y(0) = 2, \quad y'(0) = 0$$

can be written in two ways:

$$y(x) = 2 \cos x$$
$$y(x) = e^{x\sqrt{-1}} + e^{-x\sqrt{-1}}.$$

It became more and more apparent over time, as manipulations involving complex numbers became more common, that many problems in real mathematics could be more easily solved using complex mathematics. Complex numbers gained wider acceptance after Gauss developed the geometric representation of complex numbers, presented in April of 1831 in a memoir to the Royal Society of Göttingen. Gauss realized that capturing the intuitive meaning of complex numbers was sufficient to admit the numbers into the practice of mathematics. But the first formal definition was given by William Hamilton in a paper presented in June of 1835 to the Irish Academy titled "Theory of Conjugate Functions or Algebraic Couples: with a Preliminary Essay on Algebra as a Science of Pure Time." The paper was partly metaphysical, which we skip over, but with the mathematics contained therein we begin and consider the field of complex numbers.

3.1 The Complex Field

A group is an algebraic structure consisting of a set together with an operation that combines any two of its elements to form a third element. To qualify as a group, the set and the operation must satisfy a few conditions called group axioms, namely closure, associativity, identity and invertibility. An abelian group, also called a commutative group, is a group in which the result of applying the group operation to two group elements does not depend on their order.

A ring is an algebraic structure consisting of a set together with two binary operations usually called addition and multiplication, where the set is an abelian group under addition. A commutative ring is a ring in which the multiplication operation is commutative.

A field is a commutative ring whose nonzero elements form a group under multiplication. The complex numbers form a field, the complex field, which is denoted by the symbol \mathbb{C} .

As we shall soon see, complex numbers can be written in the form $a + bi$, where $a, b \in \mathbb{R}$ and $i = \sqrt{-1}$. But such a statement is not a formal definition, for it assumes that $\sqrt{-1}$ makes sense in any system. The existence of a system in which a quantity such as $\sqrt{-1}$ does make sense is what needs to be established. Furthermore, the operations of "addition" and "multiplication" that appear in the expression $a + bi$ have not been defined in terms of such a system. Hamilton's formal definition that follows defines these operations in terms of ordered pairs.

The complex field \mathbb{C} is the set of ordered pairs or real numbers (a, b) with addition and multiplication defined by

$$\begin{aligned}(a, b) + (c, d) &= (a + c, b + d) \\ (a, b)(c, d) &= (ac - bd, ad + bc).\end{aligned}\tag{3.1}$$

The associative and commutative laws for addition and multiplication as well as the distributive law are a direct consequence of the very same

properties for the real numbers. The additive identity, what we shall call "zero", is $(0, 0)$ and the additive inverse of (a, b) is $(-a, -b)$. The multiplicative identity is $(1, 0)$.

Now to find the multiplicative inverse of any nonzero (a, b) :

Set

$$(a, b)(x, y) = (1, 0),$$

Then

$$\begin{aligned} ax - by &= 1 \\ bx + ay &= 0. \end{aligned}$$

As the reader can easily verify, the system of equations has solutions

$$x = \frac{a}{a^2 + b^2}, \quad y = \frac{-b}{a^2 + b^2}.$$

The complex numbers thus form a field.

The subset of \mathbb{C} having the form $(a, 0)$ is isomorphic to \mathbb{R} , meaning all operations are preserved. $(0, 1)$ is $\sqrt{-1}$ since

$$(0, 1)(0, 1) = (-1, 0) = -1 \text{ and we denote } i = (0, 1) = \sqrt{-1}.$$

Hamilton's formality is important for understanding why complex numbers are written the way they are; they are written in the form $a + bi$ because any complex number (a, b) can be written as

$$(a, b) = (a, 0) + (0, b) = (a, 0) + (b, 0)(0, 1) = a + bi.$$

Consider a complex number $z = (x, y)$. x is called the real part and y the imaginary part of z , written

$$x = \operatorname{Re} z, \quad y = \operatorname{Im} z.$$

By definition, two complex numbers are equal if and only if their real parts are equal and their imaginary parts are equal. $i = (0, 1)$ is called the imaginary unit. If $x = 0$, then $z = iy$ and is called pure imaginary.

The notation $z = x + iy$ for complex numbers is exclusively used in practice. For addition it gives

$$(x_1 + iy_1) + (x_2 + iy_2) = (x_1 + x_2) + i(y_1 + y_2).$$

For multiplication it gives the following very simple recipe. Multiply each term by each term and use $i^2 = -1$ when it occurs:

$$\begin{aligned}(x_1 + iy_1)(x_2 + iy_2) &= x_1x_2 + ix_1y_2 + iy_1x_2 + i^2y_1y_2 \\ &= (x_1x_2 - y_1y_2) + i(x_1y_2 + x_2y_1).\end{aligned}$$

Example 3.1. Let $z_1 = 8 + 3i$ and $z_2 = 9 - 2i$. Then $\operatorname{Re} z_1 = 8$, $\operatorname{Im} z_1 = 3$, $\operatorname{Re} z_2 = 9$, $\operatorname{Im} z_2 = -2$ and

$$\begin{aligned}z_1 + z_2 &= (8 + 3i) + (9 - 2i) = 17 + i \\ z_1z_2 &= (8 + 3i)(9 - 2i) = (72 + 6) + i(-16 + 27) = 78 + 11i\end{aligned}$$

■

Subtraction and division are defined as the inverse operations of addition and multiplication, respectively. Thus the difference $z = z_1 - z_2$ is the complex number z for which $z_1 = z + z_2$. Hence,

$$z_1 - z_2 = (x_1 - x_2) + i(y_1 - y_2). \quad (3.2)$$

The quotient $z = z_1/z_2$ ($z_2 \neq 0$) is the complex number z for which $z_1 = zz_2$. The practical way to get the rule is by multiplying numerator and denominator of z_1/z_2 by $x_2 - iy_2$ and simplifying:

$$z = \frac{x_1 + iy_1}{x_2 + iy_2} = \frac{(x_1 + iy_1)(x_2 - iy_2)}{(x_2 + iy_2)(x_2 - iy_2)} = \frac{x_1x_2 + y_1y_2}{x_2^2 + y_2^2} + i\frac{x_2y_1 - x_1y_2}{x_2^2 + y_2^2}. \quad (3.3)$$

Example 3.2. For $z_1 = 8 + 3i$ and $z_2 = 9 - 2i$ we get

$$\begin{aligned}z_1 - z_2 &= (8 + 3i) - (9 - 2i) = -1 + 5i \\ \frac{z_1}{z_2} &= \frac{8 + 3i}{9 - 2i} = \frac{(8 + 3i)(9 + 2i)}{(9 - 2i)(9 + 2i)} = \frac{66 + 43i}{81 + 4} = \frac{66}{85} + i\frac{43}{85}\end{aligned}$$

■

Properties of addition and multiplication are the same as for real numbers, from which they follow (here, $-z = -x - iy$):

Commutative laws:

$$\begin{aligned}z_1 + z_2 &= z_2 + z_1 \\z_1 z_2 &= z_2 z_1\end{aligned}$$

Associative laws:

$$\begin{aligned}(z_1 + z_2) + z_3 &= z_1 + (z_2 + z_3) \\(z_1 z_2) z_3 &= z_1 (z_2 z_3)\end{aligned}$$

Distributive law:

$$z_1(z_2 + z_3) = z_1 z_2 + z_1 z_3$$

We also have:

$$\begin{aligned}0 + z &= z + 0 = z \\z + (-z) &= (-z) + z = 0 \\z \cdot 1 &= z\end{aligned}$$

3.2 The Complex Plane

This was algebra. Now comes geometry: the geometrical representation of complex numbers as points in the plane. This is of great practical importance. The idea is quite simple and natural. We choose two perpendicular coordinate axes, the horizontal x -axis, called the real axis, and the vertical y -axis, called the imaginary axis. On both axes we choose the same unit of length.

This is called a Cartesian coordinate system. We now plot a given complex number $z = (x, y) = x + iy$ as the point P with coordinates x, y . The xy -plane in which the complex numbers are represented in this way is called the complex plane. The complex plane is sometimes called the Argand diagram, after the French mathematician Jean Robert Argand (1768-1822), born in Geneva and later librarian in Paris. His paper on the complex plane appeared in 1806, nine years after a similar memoir by the Norwegian mathematician Casper Wessel (1745-1818), a surveyor of the Danish Academy of Science.

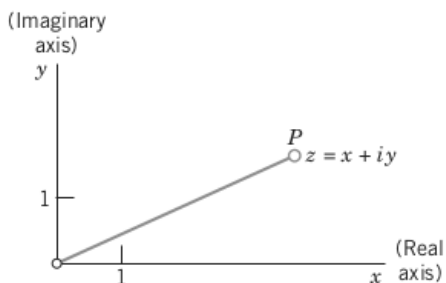

Figure 3.1: The complex plane

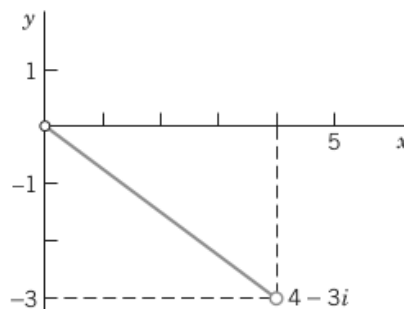

Figure 3.2: The number $4 - 3i$ in the complex plane

Instead of saying "the point represented by z in the complex plane" we say briefly and simply "the point z in the complex plane." This will cause no misunderstandings. Addition and subtraction can now be visualized as illustrated in the following figures.

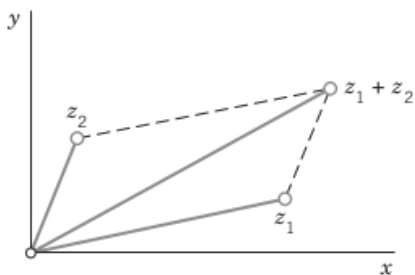

Figure 3.3: Addition of complex numbers

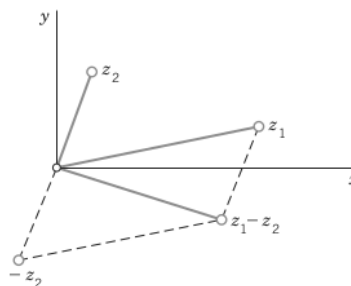

Figure 3.4: Subtraction of complex numbers

3.3 Complex Conjugate Numbers

The complex conjugate \bar{z} of a complex number

$$z = x + iy \text{ is defined by } \bar{z} = x - iy$$

and is obtained geometrically by reflecting the point z across the real axis, as shown in the next figure.

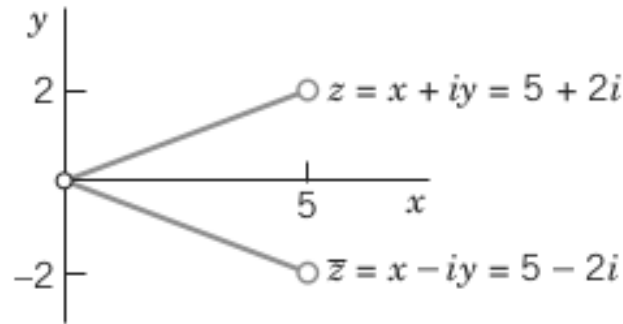

Figure 3.5: Complex conjugate numbers

Conjugates are useful since $z\bar{z} = x^2 + y^2$ is real. Moreover, addition and subtraction yield $z + \bar{z} = 2x$ and $z - \bar{z} = 2iy$, so that we can express the real part and the imaginary part of z by the important formulas

$$\operatorname{Re} z = x = \frac{1}{2}(z + \bar{z}), \quad \operatorname{Im} z = y = \frac{1}{2i}(z - \bar{z}). \quad (3.4)$$

If z is real, $z = x$ and $z = \bar{z}$ and conversely.

Working with conjugates is easy, since we have

$$\begin{aligned} \overline{(z_1 + z_2)} &= \bar{z}_1 + \bar{z}_2, & \overline{(z_1 - z_2)} &= \bar{z}_1 - \bar{z}_2 \\ \overline{(z_1 z_2)} &= \bar{z}_1 \bar{z}_2, & \overline{\left(\frac{z_1}{z_2}\right)} &= \frac{\bar{z}_1}{\bar{z}_2}. \end{aligned}$$

Example 3.3. Let $z_1 = 4 + 3i$ and $z_2 = 2 + 5i$. Then

$$\begin{aligned} \operatorname{Im} z_1 &= \frac{1}{2i}[(4 + 3i) - (4 - 3i)] = \frac{3i + 3i}{2i} = 3 \\ \overline{(z_1 z_2)} &= \overline{(4 + 3i)(2 + 5i)} = \overline{-7 + 26i} = -7 - 26i \\ \bar{z}_1 \bar{z}_2 &= (4 - 3i)(2 - 5i) = -7 - 26i \end{aligned}$$

■

Example 3.4. (Powers of the imaginary unit)

$i^2 = -1$ since $i^2 = (0, 1)(0, 1) = (-1, 0) = -1$ by the definition of complex multiplication. Therefore,

$$i^3 = -i, i^4 = 1, i^5 = i, \dots$$

From these it follows that

$$\frac{1}{i} = -i, \frac{1}{i^2} = -1, \frac{1}{i^3} = i, \dots$$

Example 3.5. Let $z_1 = 4 - 5i$ and $z_2 = 2 + 3i$. Find in the form $x + iy$:

a) $(z_1 + z_2)^2 = (6 - 2i)^2 = 32 - 24i$

b) $\frac{z_2}{z_1} = \frac{(2 + 3i)}{(4 - 5i)} \cdot \frac{(4 + 5i)}{(4 + 5i)} = -\frac{7}{41} + \frac{22}{41}i$

Example 3.6. Find

a) $\operatorname{Re} \frac{1}{1+i} = \operatorname{Re} \left[\frac{1}{1+i} \cdot \frac{1-i}{1-i} \right] = \operatorname{Re} \frac{1-i}{1+1} = \operatorname{Re} \left(\frac{1}{2} - \frac{1}{2}i \right) = \frac{1}{2}$

b) $\operatorname{Im} \frac{3+4i}{7-i} = \operatorname{Im} \left[\frac{3+4i}{7-i} \cdot \frac{7+i}{7+i} \right] = \operatorname{Im} \left(\frac{17}{50} + \frac{31}{50}i \right) = \frac{31}{50}$

c) $\operatorname{Im} \frac{z}{\bar{z}} = \operatorname{Im} \frac{x+iy}{x-iy} \cdot \frac{x+iy}{x+iy} = \operatorname{Im} \frac{x^2 - y^2 + 2xyi}{x^2 + y^2} = \frac{2xy}{x^2 + y^2}$

d) $(1+i)^8 = (1+i)^{2 \cdot 4} = (2i)^4 = 16$

Example 3.7. If the product of two complex numbers is zero, show that at least one factor must be zero.

Proof. From the definition of complex multiplication we have,

$$x_1x_2 - y_1y_2 = 0$$

$$x_1y_2 + x_2y_1 = 0$$

Assume $(x_2, y_2) \neq 0$. Then $(x_1, y_1) = (0, 0)$ because:

Solving for x_1 ,

$$x_1 = \frac{y_1y_2}{x_2}, \quad x_1 = \frac{-x_2y_1}{y_2}.$$

Substituting the first in the second equation,

$$\frac{y_1y_2}{x_2}y_2 = -x_2y_1$$

$$y_1y_2^2 = -y_1x_2^2$$

Now if $y_1 \neq 0$ then $-x_2^2 = y_2^2$ which is impossible.

$$\therefore y_1 = 0.$$

Since $y_1 = 0$,

$$x_1x_2 - y_1y_2 = 0 \implies x_1x_2 = 0$$

and

$$x_1y_2 + x_2y_1 = 0 \implies x_1y_2 = 0$$

But we assumed $(x_2, y_2) \neq 0$,

$$\therefore x_1 = 0.$$

□

3.4 Polar Form of Complex Numbers.

We can substantially increase the usefulness of the complex plane and gain further insight into the nature of complex numbers if in addition to the xy -coordinates we also employ the usual polar coordinates r, θ defined by

$$x = r \cos \theta, \quad y = r \sin \theta.$$

Then $z = x + iy$ takes the so-called polar form

$$z = r(\cos \theta + i \sin \theta) = re^{i\theta}.$$

r is called the absolute value or modulus of z and is denoted by $|z|$. Hence

$$|z| = r = \sqrt{x^2 + y^2} = \sqrt{z\bar{z}}.$$

Geometrically, $|z|$ is the distance of the point z from the origin. Similarly, $|z_1 - z_2|$ is the distance between z_1 and z_2 .

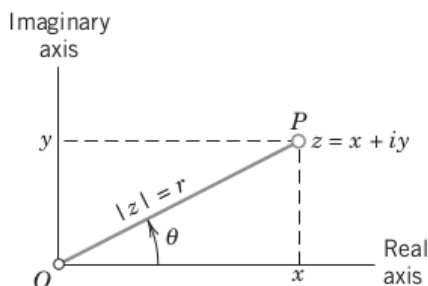

Figure 3.6: Complex plane, polar form of a complex number

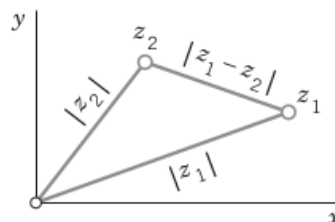

Figure 3.7: Distance between two points in the complex plane

θ is called the argument of z and is denoted $\arg z$. Thus,

$$\theta = \arg z = \arctan \frac{y}{x} \quad (z \neq 0).$$

Geometrically, θ is the directed angle from the positive x -axis to OP . Here, as in calculus, all angles are measured in radians and positive in the counterclockwise sense.

For $z = 0$ this angle θ is undefined. For given $z \neq 0$ it is determined only up to integer multiples of 2π . The value of θ that lies in the interval $-\pi < \theta \leq \pi$ is called the principal value of the argument of z ($\neq 0$) and is denoted $\text{Arg } z$. Thus $\theta = \text{Arg } z$ satisfies by definition

$$-\pi < \text{Arg } z \leq \pi.$$

Yet in many instances, it is proper to define a multivalued argument function,

$$\arg z \equiv \text{Arg } z + 2\pi n = \theta + 2\pi n, \quad n = 0, \pm 1, \pm 2, \dots$$

The multivalued argument function will become especially useful when we study the properties of the complex logarithm and complex power functions.

It is useful to have a straightforward, explicit formula for $\text{Arg } z$ in terms of $\arg z$; this is not simply a matter of subtracting $2\pi n$ from each side however, for that would make $\text{Arg } z$ multivalued. First we introduce some notation: $[x]$ designates the greatest integer function applied to x ; it means the largest integer less than or equal to the real number x . That is to say, $[x]$ is the unique integer that satisfies the inequality

$$x - 1 < [x] \leq x \text{ for real } x \text{ and integer } [x].$$

For example, $[1.7] = 1$ and $[-0.4] = -1$. With this notation, one can write $\text{Arg } z$ in terms of $\arg z$ as

$$\text{Arg } z = \arg z + 2\pi \left[\frac{1}{2} - \frac{\arg z}{2\pi} \right].$$

It is straightforward to check that $\text{Arg } z$ does indeed fall within the principal interval $-\pi < \theta \leq \pi$.

One should not plainly identify $\text{Arg } z$ with $\arctan(y/x)$. The real function $\arctan x$ is multivalued for real values of x . It is conventional to introduce a single-valued real arctangent function, called the principal value of the arctangent, which is denoted by $\text{Arctan } x$ and satisfies $-\frac{\pi}{2} \leq \text{Arctan } x \leq \frac{\pi}{2}$. Since $-\pi < \text{Arg } z \leq \pi$ it follows that $\text{Arg } z$ cannot be identified with $\text{Arctan}(y/x)$ in all regions of the complex plane. The correct relation between

these quantities is ascertained by considering the four quadrants of the complex plane. The quadrants of the complex plane are called regions I (upper right), II (upper left), III (lower left), and IV (lower right).

Table 3.1: Formulae for the argument of a complex number $z = x + iy$.

Quadrant	Sign of x and y	Arg z
I	$x > 0, y > 0$	$\text{Arctan}(y/x)$
II	$x < 0, y > 0$	$\pi + \text{Arctan}(y/x)$
III	$x < 0, y < 0$	$-\pi + \text{Arctan}(y/x)$
IV	$x > 0, y < 0$	$\text{Arctan}(y/x)$

The principal value of the argument of $z = x + iy$ in terms of its real part x and imaginary part y is given in the above table, assuming z lies within one of the four quadrants of the complex plane. Note that $\text{Arg } z = \text{Arctan}(y/x)$ is valid only in quadrants I and IV. If z lies within quadrants II or III, one must add or subtract π to ensure that $\frac{\pi}{2} < \text{Arg } z < \pi$ or $-\pi < \text{Arg } z < -\frac{\pi}{2}$ respectively.

Table 3.2: Formulae for the argument of $z = x + iy$ when z is real or pure imaginary.

Quadrant Border	type of z	x and y conditions	Arg z
IV/I	positive real	$x > 0, y = 0$	0
I/II	pure imaginary, $\text{Im } z > 0$	$x = 0, y > 0$	$\frac{\pi}{2}$
II/III	negative real	$x < 0, y = 0$	π
III/IV	pure imaginary, $\text{Im } z < 0$	$x = 0, y < 0$	$-\frac{\pi}{2}$
origin	zero	$x = y = 0$	undefined

For finite nonzero values of y/x , the principal values of the arctangent function lie inside the interval $0 < \text{Arctan}(y/x) < \pi/2$ if $y/x > 0$ and inside the interval $-\pi/2 < \text{Arctan}(y/x) < 0$ if $y/x < 0$.

Note that

$$\operatorname{Arctan}(y/x) = \begin{cases} 0, & \text{if } y = 0 \text{ and } x \neq 0, \\ \frac{\pi}{2}, & \text{if } x = 0 \text{ and } y > 0, \\ -\frac{\pi}{2}, & \text{if } x = 0 \text{ and } y < 0, \\ \text{undefined}, & \text{if } x = y = 0. \end{cases}$$

We can view a multivalued function $f(z)$ evaluated at z as a set of values, each element of the set corresponding to a different choice of some integer n . For example, given the multivalued function $\arg z$ whose principal value is $\theta = \operatorname{Arg} z$, then $\arg z$ consists of the set of values:

$$\arg z = \{\theta, \theta + 2\pi, \theta - 2\pi, \theta + 4\pi, \theta - 4\pi, \dots\}.$$

Given two multivalued functions, for example $f(z; \theta + 2\pi n)$ and $g(z; \theta + 2\pi n)$, where $f(z; \theta)$ and $g(z; \theta)$ are the principal values of $f(z)$ and $g(z)$ respectively, then $f(z) = g(z)$ if and only if for each point z , the corresponding set of values of $f(z)$ and $g(z)$ precisely coincide:

$$\begin{aligned} & \{f(z), f(z; 2\pi), f(z; -2\pi), \dots\} \\ & = \{g(z), g(z; 2\pi), g(z; -2\pi), \dots\} \end{aligned} \tag{3.5}$$

One may refer to the equation $f(z) = g(z)$ as a set equality since all the elements of the two sets in eqn. 3.5 must coincide (here the ordering of the terms is not important and only distinct, rather than duplicate elements matter, which may be deleted).

To understand how the set equality of two multivalued functions works, consider the multivalued function $\arg z$. It is provable that

$$\arg(z_1 z_2) = \arg z_1 + \arg z_2 \tag{3.6}$$

$$\arg\left(\frac{z_1}{z_2}\right) = \arg z_1 - \arg z_2 \tag{3.7}$$

$$\arg\left(\frac{1}{z}\right) = \arg \bar{z} = -\arg z \tag{3.8}$$

To prove eqn. 3.6, consider $z_1 = |z_1|e^{i\arg z_1}$ and $z_2 = |z_2|e^{i\arg z_2}$. The arguments of these two complex numbers are: $\arg z_1 = \operatorname{Arg} z_1 + 2\pi n_1$ and $\arg z_2 =$

$\text{Arg } z_2 + 2\pi n_2$, where n_1 and n_2 are arbitrary integers. One can also write $z_1 = |z_1|e^{i \text{Arg } z_1}$ and $z_2 = |z_2|e^{i \text{Arg } z_2}$ since $e^{2\pi i n} = 1$ for any integer n . It then follows that

$$z_1 z_2 = |z_1 z_2| e^{i(\text{Arg } z_1 + \text{Arg } z_2)}$$

where we used $|z_1||z_2| = |z_1 z_2|$. So we have established that

$$\begin{aligned} \arg z_1 + \arg z_2 &= \text{Arg } z_1 + \text{Arg } z_2 + 2\pi(n_1 + n_2) \\ \arg(z_1 z_2) &= \text{Arg } z_1 + \text{Arg } z_2 + 2\pi n_{12} \end{aligned}$$

where n_1 , n_2 and n_{12} are arbitrary integers. Thus, $\arg z_1 + \arg z_2$ and $\arg(z_1 z_2)$ coincide as sets, and so eqn. 3.6 is confirmed. One can prove eqns. 3.7 and 3.8 similarly. In particular, if one writes $z = |z|e^{i \arg z}$ and employs the definition of the complex conjugate (which yields $|\bar{z}| = |z|$ and $\bar{z} = |z|e^{-i \arg z}$), then it follows that $\arg\left(\frac{1}{z}\right) = \arg \bar{z} = -\arg z$. As an example, consider the last relation in the case of $z = -1$. It then follows that

$$\arg(-1) = -\arg(-1)$$

as a set equality. This is not paradoxical since the sets

$$\arg(-1) = \{\pm\pi, \pm 3\pi, \dots\} \text{ and } -\arg(-1) = \{\mp\pi, \mp 3\pi, \dots\}$$

coincide, as they possess the same list elements.

For clarity, consider the surprising fact

$$\arg z^2 \neq 2 \arg z.$$

To see why this inequality is surprising, consider the following false proof. Use eqn. 3.6 with $z_1 = z_2 = z$ to derive:

$$\arg z^2 = \arg z + \arg z \stackrel{?}{=} 2 \arg z \quad (\text{false})$$

The false step is the one indicated by the symbol $\stackrel{?}{=}$ above. Given $z = |z|e^{i \arg z}$, one finds that $z^2 = |z|^2 e^{i(2 \text{Arg } z + 2\pi n)} = |z|^2 e^{2i \text{Arg } z}$, and so the possible values of $\arg(z^2)$ are:

$$\arg(z^2) = \{2 \text{Arg } z, 2 \text{Arg } z \pm 2\pi, 2 \text{Arg } z \pm 4\pi, \dots\},$$

whereas the possible values of $2 \arg z$ are:

$$\begin{aligned} 2 \arg z &= \{2 \operatorname{Arg} z, 2(\operatorname{Arg} z \pm 2\pi), 2(\operatorname{Arg} z \pm 4\pi), \dots\} \\ &= \{2 \operatorname{Arg} z, 2 \operatorname{Arg} z \pm 4\pi, 2 \operatorname{Arg} z \pm 8\pi, \dots\} \end{aligned}$$

Therefore, $2 \arg z$ is a subset of $\arg(z^2)$, and half the elements of $\arg(z^2)$ are missing from $2 \arg z$. These are therefore unequal sets.

Here is one more example of an incorrect proof. Consider eqn. 3.7 with $z_1 = z_2 = z$. Then one may be tempted to write:

$$\arg\left(\frac{z}{z}\right) = \arg(1) = \arg z - \arg z \stackrel{?}{=} 0.$$

This is clearly wrong since $\arg(1) = 2\pi n$, where n is the set of integers. The fallacy of the questionable statement is the same as above. When you subtract $\arg z$ as a set from itself, the element chosen from the first set need not be the same as the element chosen from the second set.

The properties of the principal value $\operatorname{Arg} z$ are not as simple as those given in eqns. 3.6-3.8, since the range of $\operatorname{Arg} z$ is restricted to lie within the principal range $-\pi < \operatorname{Arg} z \leq \pi$. Instead, the following relations are satisfied:

$$\operatorname{Arg}(z_1 z_2) = \operatorname{Arg} z_1 + \operatorname{Arg} z_2 + 2\pi N_+ \quad (3.9)$$

$$\operatorname{Arg}(z_1/z_2) = \operatorname{Arg} z_1 - \operatorname{Arg} z_2 + 2\pi N_- \quad (3.10)$$

where the integers N_{\pm} are determined as follows:

$$N_{\pm} = \begin{cases} -1, & \text{if } \operatorname{Arg} z_1 \pm \operatorname{Arg} z_2 > \pi, \\ 0, & \text{if } -\pi < \operatorname{Arg} z_1 \pm \operatorname{Arg} z_2 \leq \pi, \\ 1, & \text{if } \operatorname{Arg} z_1 \pm \operatorname{Arg} z_2 \leq -\pi. \end{cases}$$

If we set $z_1 = 1$ in eqn. 3.10, we find that

$$\operatorname{Arg}\left(\frac{1}{z}\right) = \operatorname{Arg} \bar{z} = \begin{cases} \operatorname{Arg} z, & \text{if } \operatorname{Im} z = 0 \text{ and } z \neq 0, \\ -\operatorname{Arg} z, & \text{if } \operatorname{Im} z \neq 0. \end{cases}$$

Note that for z real, both $1/z$ and \bar{z} are also real so that in this case $z = \bar{z}$ and $\operatorname{Arg}(1/z) = \operatorname{Arg} \bar{z} = \operatorname{Arg} z$.

If n is an integer, then

$$\arg z^n = \arg z + \arg z + \cdots + \arg z \neq n \arg z,$$

where the final inequality was noted in the case of $n = 2$ earlier. But the corresponding property of $\text{Arg } z$ is much simpler:

$$\text{Arg}(z^n) = n \text{Arg } z + 2\pi N_n,$$

where the integer N_n is given by

$$N_n = \left\lfloor \frac{1}{2} - \frac{n}{2\pi} \text{Arg } z \right\rfloor$$

where $\lfloor \cdot \rfloor$ is the greatest integer function introduced earlier.

Example 3.8. Polar form of complex numbers. Principal value.

Let $z = 1 + i$.

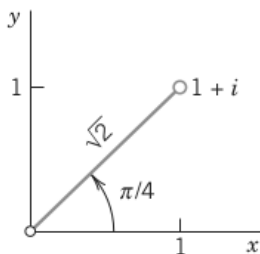

Then

$$z = \sqrt{2} \left(\cos \frac{\pi}{4} + i \sin \frac{\pi}{4} \right), \quad |z| = \sqrt{2},$$

$$\arg z = \frac{\pi}{4} \pm 2n\pi, \quad n = 0, 1, \dots$$

$$\text{Arg } z = \frac{\pi}{4}$$

■

Example 3.9. Polar form of complex numbers. Principal value.

Let $z = 3 + 3\sqrt{3}i$.

$$\theta = \text{Arctan} \left(\frac{3\sqrt{3}}{3} \right) = \text{Arctan}(\sqrt{3}) = \text{Arctan} \left(\frac{\sqrt{3}/2}{1/2} \right) = \frac{\pi}{3}$$

$$r = \sqrt{3^2 + (3\sqrt{3})^2} = \sqrt{9 + 27} = \sqrt{36} = 6$$

$$z = 6e^{i\frac{\pi}{3}}$$

$$\text{Arg } z = \frac{\pi}{3}$$

■

Example 3.10. Polar form of complex numbers. Principal value.

Let $z = -3 + 3\sqrt{3}i$.

$$\theta = \text{Arctan} \left(\frac{3\sqrt{3}}{-3} \right) + \pi = -\frac{\pi}{3} + \pi = \frac{2\pi}{3}$$

$$z = 6e^{i\frac{2\pi}{3}}$$

$$\text{Arg } z = \frac{2\pi}{3}$$

■

Triangle inequality. For any complex numbers we have the important triangle inequality

$$|z_1 + z_2| \leq |z_1| + |z_2| \tag{3.11}$$

which we will use quite frequently. This inequality follows by noting that the three points 0 , z_1 , and $z_1 + z_2$ are the vertices of a triangle with sides $|z_1|$, $|z_2|$ and $|z_1 + z_2|$, and one side cannot exceed the sum of the other two sides.

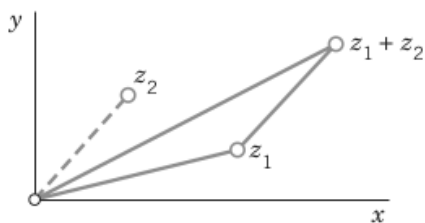

Figure 3.8: Triangle inequality

Proof. Eqn. 3.11 holds when $z_1 + z_2 = 0$. Let $z_1 + z_2 \neq 0$ and $c = a + ib = z_1/(z_1 + z_2)$.

Note that $|\operatorname{Re} z| \leq |z|$ and $|\operatorname{Im} z| \leq |z|$ so we have

$$|a| \leq |c|, \quad |a - 1| \leq |c - 1|.$$

Thus $|a| + |a - 1| \leq |c| + |c - 1|$.

Clearly $|a| + |a - 1| \geq 1$.

Taken together we have the inequality

$$1 \leq |c| + |c - 1| = \left| \frac{z_1}{z_1 + z_2} \right| + \left| \frac{z_2}{z_1 + z_2} \right|.$$

Multiply by $|z_1 + z_2|$ to get

$$|z_1 + z_2| \leq |z_1| + |z_2|.$$

□

Example 3.11. If $z_1 = 1 + i$ and $z_2 = -2 + 3i$, then

$$|z_1 + z_2| = |-1 + 4i| = \sqrt{17} = 4.123 < \sqrt{2} + \sqrt{13} = 5.020.$$

■

Generalized triangle inequality. By induction we obtain from eqn. 3.11 for any sum

$$|z_1 + z_2 + \cdots + z_n| \leq |z_1| + |z_2| + \cdots + |z_n|;$$

that is, the absolute value of a sum cannot exceed the sum of the absolute values of the terms.

3.5 Multiplication and Division in Polar Form. Powers

This will give us a better understanding of multiplication and division. Let

$$z_1 = r_1(\cos \theta_1 + i \sin \theta_1) \quad \text{and} \quad z_2 = r_2(\cos \theta_2 + i \sin \theta_2).$$

By the definition of complex multiplication, the product is at first

$$z_1 z_2 = r_1 r_2 [(\cos \theta_1 \cos \theta_2 - \sin \theta_1 \sin \theta_2) + i(\sin \theta_1 \cos \theta_2 + \cos \theta_1 \sin \theta_2)].$$

Application of trigonometric identities yields

$$z_1 z_2 = r_1 r_2 [\cos(\theta_1 + \theta_2) + i \sin(\theta_1 + \theta_2)] = r_1 r_2 e^{i(\theta_1 + \theta_2)}. \quad (3.12)$$

Taking absolute values and arguments on both sides, we thus obtain the important rules

$$|z_1 z_2| = |z_1| |z_2|$$

and

$$\arg(z_1 z_2) = \arg z_1 + \arg z_2 \quad (\text{up to multiples of } 2\pi)$$

The quotient $z = z_1/z_2$ is the number z satisfying $z z_2 = z_1$. Hence $|z z_2| = |z| |z_2| = |z_1|$ and $\arg(z z_2) = \arg z + \arg z_2 = \arg z_1$. This yields

$$\left| \frac{z_1}{z_2} \right| = \frac{|z_1|}{|z_2|} \quad (z_2 \neq 0)$$

and

$$\arg \frac{z_1}{z_2} = \arg z_1 - \arg z_2 \quad (\text{up to multiples of } 2\pi).$$

By combining these formulas we have

$$\frac{z_1}{z_2} = \frac{r_1}{r_2} [\cos(\theta_1 - \theta_2) + i \sin(\theta_1 - \theta_2)] = \frac{r_1}{r_2} e^{i(\theta_1 - \theta_2)}. \quad (3.13)$$

Example 3.12. Let $z_1 = -2 + 2i$ and $z_2 = 3i$. Then

$$\begin{aligned} z_1 z_2 &= -6 - 6i \\ \frac{z_1}{z_2} &= \frac{2}{3} + \frac{2}{3}i. \end{aligned}$$

Hence

$$\begin{aligned} |z_1 z_2| &= 6\sqrt{2} = |z_1| |z_2| = 3\sqrt{8}, \\ \left| \frac{z_1}{z_2} \right| &= \frac{2\sqrt{2}}{3} = \frac{|z_1|}{|z_2|}, \end{aligned}$$

and for the arguments we obtain $\text{Arg } z_1 = 3\pi/4$, $\text{Arg } z_2 = \pi/2$,

$$\begin{aligned} \text{Arg } z_1 z_2 &= -\frac{3\pi}{4} = \text{Arg } z_1 + \text{Arg } z_2 - 2\pi, \\ \text{Arg } \frac{z_1}{z_2} &= \frac{\pi}{4} = \text{Arg } z_1 - \text{Arg } z_2. \end{aligned}$$

■

Integer powers of z . From the formula for polar multiplication we have

$$z^2 = r^2(\cos 2\theta + i \sin 2\theta) = r^2 e^{i2\theta}.$$

Inverting this, we have

$$z^{-2} = r^{-2}[\cos(-2\theta) + i \sin(-2\theta)] = r^{-2} e^{-i2\theta},$$

and more generally, for any integer n ,

$$z^n = r^n(\cos n\theta + i \sin n\theta) = r^n e^{in\theta}. \quad (3.14)$$

Example 3.13. *Formula of De Moivre.* For $|z| = r = 1$, eqn. 3.14 yields the so-called formula of De Moivre

$$(\cos \theta + i \sin \theta)^n = \cos n\theta + i \sin n\theta.$$

This formula is useful for expressing $\cos n\theta$ and $\sin n\theta$ in terms of $\cos \theta$ and $\sin \theta$. For instance, if $n = 2$,

$$\begin{aligned} (\cos \theta + i \sin \theta)^2 &= \cos^2 \theta - \sin^2 \theta + 2 \cos \theta \sin \theta i \\ &= \cos 2\theta + i \sin 2\theta \end{aligned}$$

We get the familiar formulas by equating the real and imaginary parts of both sides:

$$\begin{aligned} \cos 2\theta &= \cos^2 \theta - \sin^2 \theta = 2 \cos^2 \theta - 1, \\ \sin 2\theta &= 2 \cos \theta \sin \theta. \end{aligned}$$

This shows that complex methods often simplify the derivation of real formulas. ■

3.6 Roots

If $z = \omega^n$ ($n = 1, 2, \dots$), then to each value of ω there corresponds one value of z . Conversely, to a given $z \neq 0$ there correspond precisely n distinct values of ω . Each of these values is called an n th root of z , and we write

$$\omega = \sqrt[n]{z}.$$

Hence this symbol is multivalued, namely, n -valued, in contrast to the usual conventions made in real calculus. The n values of $\sqrt[n]{z}$ can easily be obtained as follows. In terms of polar forms for z and

$$\omega = R(\cos \phi + i \sin \phi),$$

the equation $\omega^n = z$ becomes

$$\omega^n = R^n(\cos n\phi + i \sin n\phi) = z = r(\cos \theta + i \sin \theta).$$

By equating the absolute values on both sides we have

$$R^n = r, \quad \text{thus} \quad R = \sqrt[n]{r}$$

where the root is real positive and thus uniquely determined. By equating the arguments we obtain

$$n\phi = \theta + 2k\pi, \quad \text{thus} \quad \phi = \frac{\theta}{n} + \frac{2k\pi}{n}$$

where k is an integer.

For $k = 0, 1, \dots, n-1$ we get n distinct values of ω . Further integers of k would give values already obtained. For instance, $k = n$ gives $2k\pi/n = 2\pi$, hence the ω corresponding to $k = 0$, etc. Consequently, $\sqrt[n]{z}$, for $z \neq 0$, has the n distinct values

$$\sqrt[n]{z} = \sqrt[n]{r} \left(\cos \frac{\theta + 2k\pi}{n} + i \sin \frac{\theta + 2k\pi}{n} \right) \quad (3.15)$$

where $k = 0, 1, \dots, n-1$. These n values lie on a circle of radius $\sqrt[n]{r}$ with center at the origin and constitute the vertices of a regular polygon of n sides. The value of $\sqrt[n]{z}$ obtained by taking $\theta = \text{Arg } z$ and $k = 0$ in eqn. 3.15 is called the principal value of $\omega = \sqrt[n]{z}$.

Example 3.14. Square root.

From eqn. 3.15 it follows that $\omega = \sqrt{z}$ has the two values

$$\omega_1 = \sqrt{r} \left(\cos \frac{\theta}{2} + i \sin \frac{\theta}{2} \right) \quad (3.16)$$

and

$$\omega_2 = \sqrt{r} \left[\cos \left(\frac{\theta}{2} + \pi \right) + i \sin \left(\frac{\theta}{2} + \pi \right) \right] = -\omega_1$$

which lie symmetric with respect to the origin. For instance, the square root of $4i$ has the values

$$\sqrt{4i} = \pm 2 \left(\cos \frac{\pi}{4} + i \sin \frac{\pi}{4} \right) = \pm(\sqrt{2} + i\sqrt{2}).$$

It follows from eqn. 3.16 that if we use the trigonometric identities

$$\cos \frac{\theta}{2} = \sqrt{\frac{1}{2}(1 + \cos \theta)}, \quad \sin \frac{\theta}{2} = \sqrt{\frac{1}{2}(1 - \cos \theta)},$$

multiply them by \sqrt{r} ,

$$\sqrt{r} \cos \frac{\theta}{2} = \sqrt{\frac{1}{2}(r + r \cos \theta)}, \quad \sqrt{r} \sin \frac{\theta}{2} = \sqrt{\frac{1}{2}(r - r \cos \theta)},$$

use $r \cos \theta = x$, and finally choose the sign of $\operatorname{Im} \sqrt{z}$ so that

$$\operatorname{sign}[(\operatorname{Re} \sqrt{z})(\operatorname{Im} \sqrt{z})] = \operatorname{sign} y$$

such that $\omega_2 = -\omega_1$, we obtain the much more practical formula

$$\sqrt{z} = \pm \left[\sqrt{\frac{1}{2}(|z| + x)} + (\operatorname{sign} y)i\sqrt{\frac{1}{2}(|z| - x)} \right]$$

where $\operatorname{sign} y = 1$ if $y \geq 0$, $\operatorname{sign} y = -1$ if $y < 0$, and all square roots of positive numbers are taken with the positive sign. ■

Example 3.15. Complex quadratic equation.

Solve $z^2 - (5 + i)z + 8 + i = 0$.

Utilizing the quadratic formula and our equation from above, we have

$$\begin{aligned} z &= \frac{1}{2}(5 + i) \pm \sqrt{\frac{1}{4}(5 + i)^2 - 8 - i} = \frac{1}{2}(5 + i) \pm \sqrt{\frac{1}{4}(24 + 10i) - 8 - i} \\ &= \frac{1}{2}(5 + i) \pm \sqrt{6 + \frac{5}{2}i - 8 - i} = \frac{1}{2}(5 + i) \pm \sqrt{-2 + \frac{3}{2}i} \\ &= \frac{1}{2}(5 + i) \pm \left[\sqrt{\frac{1}{2} \left(\frac{5}{2} + (-2) \right)} + i\sqrt{\frac{1}{2} \left(\frac{5}{2} - (-2) \right)} \right] \\ &= \frac{1}{2}(5 + i) \pm \left[\frac{1}{2} + \frac{3}{2}i \right] = \begin{cases} 3 + 2i \\ 2 - i. \end{cases} \end{aligned}$$

■

Example 3.16. n th root of unity. Unit circle.

Solve the equation $z^n = 1$.

From the equation for the n th root of a complex number we obtain

$$\sqrt[n]{1} = \cos \frac{2k\pi}{n} + i \sin \frac{2k\pi}{n}, \quad k = 0, 1, \dots, n-1.$$

If ω denotes the value corresponding to $k = 1$, then the n values of $\sqrt[n]{1}$ can be written as $1, \omega, \omega^2, \dots, \omega^{n-1}$. These values are the vertices of a regular polygon of n sides inscribed in the unit circle (the circle of radius 1 with center 0), with one vertex at the point 1. Each of these n values is called an n th root of unity. For instance, $\sqrt[3]{1} = 1, -\frac{1}{2} \pm \frac{\sqrt{3}}{2}i$ and $\sqrt[4]{1} = 1, i, -1, -i$.

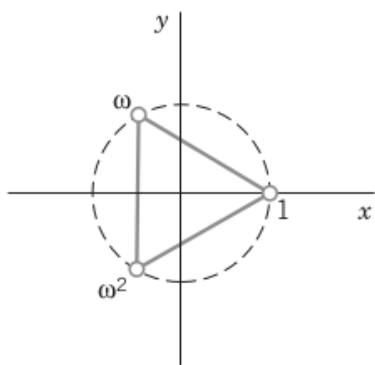

Figure 3.9: $\sqrt[3]{1}$

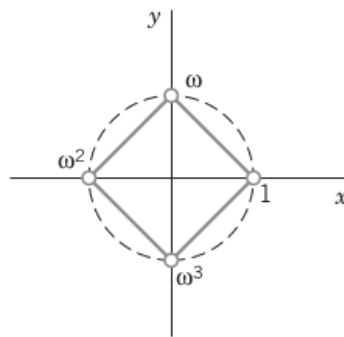

Figure 3.10: $\sqrt[4]{1}$

If w_1 is any n th root of an arbitrary complex number z , then the n values of $\sqrt[n]{z}$ are

$$w_1, w_1\omega, w_1\omega^2, \dots, w_1\omega^{n-1}$$

since multiplying w_1 by ω^k corresponds to increasing the argument of w_1 by $2k\pi/n$. ■

Example 3.17. Find the five exact algebraic expressions for the 5th roots of unity $\sqrt[5]{1}$.

solution:

First off we know $\omega^0 = 1$.

Next, we know $\omega^1 = \cos \frac{2\pi}{5} + i \sin \frac{2\pi}{5}$, but this is not an algebraic expression.

Exact values of $\cos \frac{2\pi}{5}$ and $\sin \frac{2\pi}{5}$ are not commonly known, so we must find them.

We'll start by making the observation

$$\cos \left(\frac{4\pi}{5} \right) = \cos \left(\frac{6\pi}{5} \right).$$

So if $\theta = \frac{2\pi}{5}$ we have $\cos 2\theta = \cos 3\theta$. Next derive identities for $\cos 2\theta$ and $\cos 3\theta$ in terms of $\cos \theta$. Use De Moivre's formula and the fact $\sin^2 \theta + \cos^2 \theta = 1$.

$$\begin{aligned} (\cos \theta + i \sin \theta)^2 &= \cos^2 \theta - \sin^2 \theta + (2 \cos \theta \sin \theta)i \\ &= \cos 2\theta + i \sin 2\theta \\ \cos 2\theta &= \cos^2 \theta - \sin^2 \theta = 2 \cos^2 \theta - 1 \\ \sin 2\theta &= 2 \cos \theta \sin \theta \end{aligned}$$

$$\begin{aligned} (\cos \theta + i \sin \theta)^3 &= (\cos^2 \theta - \sin^2 \theta + (2 \cos \theta \sin \theta)i)(\cos \theta + i \sin \theta) \\ &= \cos^3 \theta - \sin^2 \theta \cos \theta - 2 \cos \theta \sin^2 \theta \\ &\quad + (\cos^2 \theta \sin \theta - \sin^3 \theta + 2 \cos^2 \theta \sin \theta)i \\ &= \cos 3\theta + i \sin 3\theta \end{aligned}$$

$$\begin{aligned} \cos 3\theta &= \cos^3 \theta - (1 - \cos^2 \theta) \cos \theta - 2 \cos \theta (1 - \cos^2 \theta) \\ &= \cos^3 \theta + \cos^3 \theta - \cos \theta - 2 \cos \theta + 2 \cos^3 \theta \\ &= 4 \cos^3 \theta - 3 \cos \theta \end{aligned}$$

$$\begin{aligned} \sin 3\theta &= 3 \cos^2 \theta \sin \theta - \sin^3 \theta \\ &= 3(1 - \sin^2 \theta) \sin \theta - \sin^3 \theta \\ &= 3 \sin \theta - 4 \sin^3 \theta \end{aligned}$$

78 Chapter 3 The Complex Field

So we have $\cos 2\theta = 2\cos^2\theta - 1$ and $\cos 3\theta = 4\cos^3\theta - 3\cos\theta$ and the condition $\cos 2\theta = \cos 3\theta$.

Replacing $\cos\theta$ by x :

$$\begin{aligned}4x^3 - 2x^2 - 3x + 1 &= 0 \\(x - 1)(4x^2 + 2x - 1) &= 0\end{aligned}$$

We know that $x \neq 1$, so we are left to solve the quadratic part:

$$\begin{aligned}x &= \frac{-2 \pm \sqrt{2^2 - 4 \cdot 4 \cdot (-1)}}{2 \cdot 4} \\x &= \frac{-2 \pm \sqrt{20}}{8}\end{aligned}$$

Since $x > 0$,

$$x = \cos\left(\frac{2\pi}{5}\right) = \frac{-1 + \sqrt{5}}{4}.$$

Now to solve for $\sin\left(\frac{2\pi}{5}\right)$.

We already know

$$\sin 2\theta = 2\sin\theta\cos\theta = 2\sin\theta\left(\frac{-1 + \sqrt{5}}{4}\right)$$

and

$$\sin 3\theta = 3\sin\theta - 4\sin^3\theta.$$

Note that

$$\sin\left(\frac{4\pi}{5}\right) = -\sin\left(\frac{6\pi}{5}\right),$$

so $\sin 2\theta = -\sin 3\theta$ if $\theta = \frac{2\pi}{5}$.

So we have

$$2\left(\frac{-1 + \sqrt{5}}{4}\right)\sin\theta = -3\sin\theta + 4\sin^3\theta$$

Replacing $\sin \theta$ by y :

$$4y^3 - 3y - 2 \left(\frac{-1 + \sqrt{5}}{4} \right) y = 0$$

$$4y^3 - \frac{5 + \sqrt{5}}{2} y = 0$$

$$4y^2 - \frac{5 + \sqrt{5}}{2} = 0$$

$$y = \sqrt{\frac{5 + \sqrt{5}}{8}}$$

So we have

$$\omega^1 = \frac{1}{4}(-1 + \sqrt{5}) + i\sqrt{\frac{5 + \sqrt{5}}{8}}$$

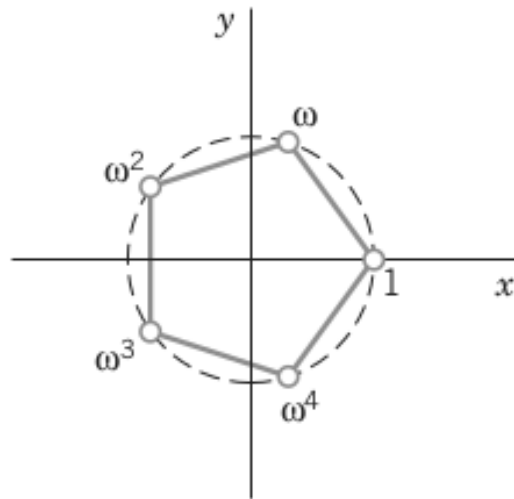

Figure 3.11: $\sqrt[5]{1}$

Next we calculate $\omega^2 = \omega^1\omega^1$, $\omega^3 = \omega^2\omega^1$, and $\omega^4 = \omega^3\omega^1$. The results are:

$$\begin{aligned}\omega^0 &= 1 \\ \omega^1 &= \frac{1}{4}(-1 + \sqrt{5}) + i\sqrt{\frac{5 + \sqrt{5}}{8}} \\ \omega^2 &= -\frac{1}{4}(1 + \sqrt{5}) + i\sqrt{\frac{5 - \sqrt{5}}{8}} \\ \omega^3 &= -\frac{1}{4}(1 + \sqrt{5}) - i\sqrt{\frac{5 - \sqrt{5}}{8}} \\ \omega^4 &= \frac{1}{4}(-1 + \sqrt{5}) - i\sqrt{\frac{5 + \sqrt{5}}{8}}\end{aligned}$$

■

3.7 Review Examples

Example 3.18. (Multiplication by i) Show that multiplication of a complex number by i corresponds to a counterclockwise rotation of the corresponding vector through the angle $\pi/2$.

$$\begin{aligned}\arg(z_1 z_2) &= \arg z_1 + \arg z_2 \\ \arg(z_1 i) &= \arg z_1 + \arg i = \arg z_1 + \frac{\pi}{2}\end{aligned}$$

■

Example 3.19. Find

a) $|1.5 + 2i| = \sqrt{1.5^2 + 2^2} = \sqrt{6.25} = 2.5$

b) $|\cos \theta + i \sin \theta| = \sqrt{\cos^2 \theta + \sin^2 \theta} = \sqrt{1} = 1$

c) $\left| \frac{5 + 7i}{7 - 5i} \right| = \left| \frac{5 + 7i}{7 - 5i} \cdot \frac{7 + 5i}{7 + 5i} \right| = \left| \frac{74i}{74} \right| = |i| = \sqrt{0^2 + 1^2} = 1$

$$\mathbf{d)} \left| \frac{(1+i)^6}{i^3(1+4i)^2} \right|$$

$$(1+i)^2 = 2i$$

$$(1+i)^6 = (2i)^3 = -8i$$

$$(1+4i)^2 = -15 + 8i$$

$$i^3 = -i$$

$$\begin{aligned} \left| \frac{(1+i)^6}{i^3(1+4i)^2} \right| &= \left| \frac{-8i}{8+15i} \right| = \left| \frac{-8i}{8+15i} \cdot \frac{8-15i}{8-15i} \right| \\ &= \left| \frac{120-64i}{64+225} \right| = \left| \frac{120-64i}{289} \right| \\ &= \sqrt{\left(\frac{120}{289}\right)^2 + \left(\frac{64}{289}\right)^2} = \sqrt{\frac{14400}{289^2} + \frac{4096}{289^2}} \\ &= \sqrt{\frac{18496}{289^2}} = \frac{136}{289} \cdot \frac{1/17}{1/17} = \frac{8}{17} \end{aligned}$$

■

Example 3.20. Represent in polar form:

$$\mathbf{a)} 1+i = \sqrt{2}\left(\cos \frac{\pi}{4} + i \sin \frac{\pi}{4}\right)$$

$$\mathbf{b)} 6+8i$$

$$r = \sqrt{36+64} = \sqrt{100} = 10$$

$$\theta = \text{Arg } z = \text{Arctan} \frac{8}{6} = 0.927$$

$$6+8i = 10(\cos 0.927 + i \sin 0.927)$$

$$\mathbf{c)} \frac{i\sqrt{2}}{4+4i}$$

$$\begin{aligned} \frac{i\sqrt{2}}{4+4i} \cdot \frac{4-4i}{4-4i} &= \frac{4\sqrt{2} + i4\sqrt{2}}{16+16} = \frac{4+4i}{32/\sqrt{2}} \\ &= \frac{4+4i}{16\sqrt{2}} = \frac{1+i}{4\sqrt{2}} \end{aligned}$$

$$r = \sqrt{\frac{1}{32} + \frac{1}{32}} = \sqrt{1/16} = 1/4$$

$$\theta = \pi/4$$

$$\frac{i\sqrt{2}}{4 + 4i} = \frac{1}{4} \left(\cos \frac{\pi}{4} + i \sin \frac{\pi}{4} \right)$$

d) $\frac{2 + 3i}{5 + 4i}$

$$\frac{2 + 3i}{5 + 4i} = \frac{2 + 3i}{5 + 4i} \cdot \frac{5 - 4i}{5 - 4i} = \frac{22 + 7i}{41}$$

$$r = \sqrt{\left(\frac{22}{41}\right)^2 + \left(\frac{7}{41}\right)^2} = 0.563$$

$$\theta = \text{Arctan} \left(\frac{7}{22} \right) = 0.308$$

$$\frac{2 + 3i}{5 + 4i} = 0.563(\cos 0.308 + i \sin 0.308)$$

■

Example 3.21. Determine the principal value of the arguments of

a) $-10 - i$

$$\theta = \text{Arctan} \frac{-1}{-10} - \pi = \text{Arctan} \frac{1}{10} - \pi = -3.042$$

b) $2 + 2i$

$$\theta = \text{Arctan} 1 = \frac{\pi}{4}$$

■

Example 3.22. Represent in the form $x + iy$:

a) $2\sqrt{2} \left(\cos \frac{3\pi}{4} + i \sin \frac{3\pi}{4} \right)$

$$2\sqrt{2} = \sqrt{8} = \sqrt{4+4} = \sqrt{2^2 + 2^2}$$

$$|x| = |y| = 2$$

$$\theta = \frac{3\pi}{4}$$

$$x + iy = -2 + 2i$$

b) $\cos(-1.8) + i \sin(-1.8) = -0.227 - 0.974i$ numerically. ■

Example 3.23. Find all values of the following roots.

a) $\sqrt{-8i}$

$$\sqrt[n]{z} = \sqrt[n]{r} \left(\cos \frac{\theta + 2k\pi}{n} + i \sin \frac{\theta + 2k\pi}{n} \right)$$

$$\omega = \sqrt{z} \text{ has two values } k = 0, 1.$$

$$\omega_1 = \sqrt{r} \left(\cos \frac{\theta}{2} + i \sin \frac{\theta}{2} \right)$$

$$\omega_2 = \sqrt{r} \left[\cos \left(\frac{\theta}{2} + \pi \right) + i \sin \left(\frac{\theta}{2} + \pi \right) \right] = -\omega_1$$

$$-8i = 8 \exp \left(-i \frac{\pi}{2} \right)$$

$$\omega_1 = 2\sqrt{2} \left[\cos \left(-\frac{\pi}{4} \right) + i \sin \left(-\frac{\pi}{4} \right) \right]$$

$$= 2\sqrt{2} \left[\frac{\sqrt{2}}{2} + i \left(\frac{-\sqrt{2}}{2} \right) \right] = 2 - 2i$$

$$\omega_2 = -\omega_1 = -2 + 2i$$

$$\sqrt{-8i} = \pm(2 - 2i)$$

b) $\sqrt[8]{1}$

$$\omega^0 = 1$$

$$\omega^1 = \cos \frac{2\pi}{8} + i \sin \frac{2\pi}{8} = \cos \frac{\pi}{4} + i \sin \frac{\pi}{4} = \frac{1}{\sqrt{2}} + \frac{1}{\sqrt{2}}i$$

$$\omega^2 = \omega^1 \omega^1 = \left(\frac{1}{\sqrt{2}} + \frac{1}{\sqrt{2}}i \right) \left(\frac{1}{\sqrt{2}} + \frac{1}{\sqrt{2}}i \right) = i$$

$$\omega^3 = \omega^2 \omega^1 = i \left(\frac{1}{\sqrt{2}} + \frac{1}{\sqrt{2}}i \right) = -\frac{1}{\sqrt{2}} + \frac{1}{\sqrt{2}}i$$

$$\omega^4 = \omega^3 \omega^1 = \left(-\frac{1}{\sqrt{2}} + \frac{1}{\sqrt{2}}i \right) \left(\frac{1}{\sqrt{2}} + \frac{1}{\sqrt{2}}i \right) = -1$$

$$\omega^5 = \omega^4 \omega^1 = -1 \left(\frac{1}{\sqrt{2}} + \frac{1}{\sqrt{2}}i \right) = -\frac{1}{\sqrt{2}} - \frac{1}{\sqrt{2}}i$$

$$\omega^6 = \omega^5 \omega^1 = \left(-\frac{1}{\sqrt{2}} - \frac{1}{\sqrt{2}}i \right) \left(\frac{1}{\sqrt{2}} + \frac{1}{\sqrt{2}}i \right) = -i$$

$$\omega^7 = \omega^6 \omega^1 = -i \left(\frac{1}{\sqrt{2}} + \frac{1}{\sqrt{2}}i \right) = \frac{1}{\sqrt{2}} - \frac{1}{\sqrt{2}}i$$

In summary, $\sqrt[8]{1} = \pm 1, \pm i, \pm(1 \pm i)/\sqrt{2}$.

c) $\sqrt[4]{-1}$

$(1+i)^2 = 2i \implies (1+i)^4 = -4$ so a fourth root of -1 is $\frac{1+i}{\sqrt{2}}$.

$$w_1 = \frac{1+i}{\sqrt{2}}$$

The fourth roots of unity are $1, \omega = i, \omega^2 = -1, \omega^3 = -i$.

$$w_2 = w_1 \omega = \frac{1+i}{\sqrt{2}}i = -\frac{1}{\sqrt{2}} + \frac{1}{\sqrt{2}}i$$

$$w_3 = w_1 \omega^2 = \frac{1+i}{\sqrt{2}}(-1) = -\frac{1}{\sqrt{2}} - \frac{1}{\sqrt{2}}i$$

$$w_4 = w_1 \omega^3 = \frac{1+i}{\sqrt{2}}(-i) = \frac{1}{\sqrt{2}} - \frac{1}{\sqrt{2}}i$$

In summary, $\sqrt[4]{-1} = \pm(1 \pm i)/\sqrt{2}$.

d) $\sqrt[3]{1+i}$

$$1+i: r = \sqrt{2}, \theta = \pi/4$$

$$\sqrt[3]{1+i} = \sqrt[3]{r} \left(\cos \frac{\pi/4 + 2k\pi}{3} + i \sin \frac{\pi/4 + 2k\pi}{3} \right), \quad k = 0, 1, 2$$

$$\sqrt[3]{1+i} = \sqrt[6]{2} \left(\cos \frac{k\pi}{12} + i \sin \frac{k\pi}{12} \right), \quad k = 1, 9, 17$$

■

Example 3.24. Solve the equation $z^2 - (5+i)z + 8+i = 0$.

Utilizing the quadratic formula and

$$\sqrt{z} = \pm \left[\sqrt{\frac{1}{2}(|z| + x)} + (\text{sign } y)i\sqrt{\frac{1}{2}(|z| - x)} \right] \quad \text{we have}$$

$$\begin{aligned} z &= \frac{1}{2}(5+i) \pm \sqrt{\frac{1}{4}(5+i)^2 - 8-i} = \frac{1}{2}(5+i) \pm \sqrt{-2 + \frac{3}{2}i} \\ &= \frac{1}{2}(5+i) \pm \left[\sqrt{\frac{1}{2} \left(\frac{5}{2} + (-2) \right)} + i\sqrt{\frac{1}{2} \left(\frac{5}{2} - (-2) \right)} \right] \\ &= \frac{1}{2}(5+i) \pm \left[\frac{1}{2} + \frac{3}{2}i \right] = \begin{cases} 3 + 2i \\ 2 - i \end{cases} \end{aligned}$$

■

Example 3.25. (Parallelogram equality)

Show that $|z_1 + z_2|^2 + |z_1 - z_2|^2 = 2(|z_1|^2 + |z_2|^2)$.

Proof.

$$\begin{aligned} |z_1|^2 &= x_1^2 + y_1^2 \\ |z_2|^2 &= x_2^2 + y_2^2 \\ |z_1 + z_2|^2 &= (x_1 + x_2)^2 + (y_1 + y_2)^2 = x_1^2 + x_2^2 + 2x_1x_2 + y_1^2 + y_2^2 + 2y_1y_2 \\ |z_1 - z_2|^2 &= (x_1 - x_2)^2 + (y_1 - y_2)^2 = x_1^2 + x_2^2 - 2x_1x_2 + y_1^2 + y_2^2 - 2y_1y_2 \\ |z_1 + z_2|^2 + |z_1 - z_2|^2 &= 2x_1^2 + 2x_2^2 + 2y_1^2 + 2y_2^2 \\ &= 2(|z_1|^2 + |z_2|^2) \end{aligned}$$

□

3.8 Topological Aspects of the Complex Plane

Sequences and Series. The concept of absolute value can be used to define the notion of a limit of a sequence of complex numbers.

Definition 3.1. The sequence z_1, z_2, z_3, \dots converges to z if the sequence of real numbers $|z_n - z|$ converges to 0. That is, $z_n \rightarrow z$ if $|z_n - z| \rightarrow 0$.

Geometrically, $z_n \rightarrow z$ if each disc about z contains all but finitely many of the members of the sequence $\{z_n\}$.

Since

$$|\operatorname{Re} z|, |\operatorname{Im} z| \leq |z| \leq |\operatorname{Re} z| + |\operatorname{Im} z|$$

$z_n \rightarrow z$ if and only if $\operatorname{Re} z_n \rightarrow \operatorname{Re} z$ and $\operatorname{Im} z_n \rightarrow \operatorname{Im} z$.

Example 3.26. Limits of sequences.

a) $z^n \rightarrow 0$ if $|z| < 1$ since $|z^n - 0| = |z^n| \rightarrow 0$.

b) $\frac{n}{n+i} \rightarrow 1$ since

$$\begin{aligned} \left| \frac{n}{n+i} - 1 \right| &= \left| \frac{-i}{n+i} \right| = \left| \frac{-i}{n+i} \cdot \frac{n-i}{n-i} \right| = \left| \frac{-1-in}{n^2+1} \right| \\ &= \sqrt{\left(\frac{-1}{n^2+1} \right)^2 + \left(\frac{-n}{n^2+1} \right)^2} = \sqrt{\frac{n^2+1}{(n^2+1)^2}} = \frac{1}{\sqrt{n^2+1}} \rightarrow 0. \end{aligned}$$

■

Definition 3.2. $\{z_n\}$ is called a Cauchy sequence if for each $\epsilon > 0$ there exists an integer N such that $n, m > N$ implies $|z_n - z_m| < \epsilon$.

Proposition 3.1. $\{z_n\}$ converges if and only if $\{z_n\}$ is a Cauchy sequence.

Proof. If $z_n \rightarrow z$, then $\operatorname{Re} z_n \rightarrow \operatorname{Re} z$, $\operatorname{Im} z_n \rightarrow \operatorname{Im} z$ and hence $\{\operatorname{Re} z_n\}$ and $\{\operatorname{Im} z_n\}$ are Cauchy sequences. But since

$$\begin{aligned} |z_n - z_m| &\leq |\operatorname{Re}(z_n - z_m)| + |\operatorname{Im}(z_n - z_m)| \\ &= |\operatorname{Re} z_n - \operatorname{Re} z_m| + |\operatorname{Im} z_n - \operatorname{Im} z_m|, \end{aligned}$$

$\{z_n\}$ is also a Cauchy sequence.

Conversely, if $\{z_n\}$ is a Cauchy sequence so are the real sequences $\{\operatorname{Re} z_n\}$ and $\{\operatorname{Im} z_n\}$. Hence both $\{\operatorname{Re} z_n\}$ and $\{\operatorname{Im} z_n\}$ converge, and thus $\{z_n\}$ converges. □

An infinite series $\sum_{k=1}^{\infty} z_k$ is said to converge if the sequence $\{s_n\}$ of partial sums, defined by $s_n = z_1 + z_2 + \cdots + z_n$, converges. If so, the limit of the sequence is called the sum of the series. The basic properties of infinite series listed below will be familiar from the theory of real series.

i. The sum and the difference of two convergent series are convergent.

ii. A necessary condition for $\sum_{k=1}^{\infty} z_k$ to converge is that $z_n \rightarrow 0$ as $n \rightarrow \infty$.

iii. A sufficient condition for $\sum_{k=1}^{\infty} z_k$ to converge is that $\sum_{k=1}^{\infty} |z_k|$ converges.

When $\sum_{k=1}^{\infty} |z_k|$ converges, we will say $\sum_{k=1}^{\infty} z_k$ is absolutely convergent.

Property (iii), which will be important in later chapters, follows from Proposition 3.1. For if $\sum_{k=1}^{\infty} |z_k|$ converges and $t_n = |z_1| + |z_2| + \cdots + |z_n|$ then $\{t_n\}$ is a Cauchy sequence. But then so is the sequence $\{s_n\}$ given by $s_n = z_1 + z_2 + \cdots + z_n$, since

$$\begin{aligned} |s_m - s_n| &= |z_{n+1} + z_{n+2} + \cdots + z_m| \\ &\leq |z_{n+1}| + |z_{n+2}| + \cdots + |z_m| = |t_m - t_n| \end{aligned}$$

by the triangle inequality. Hence $\sum_{k=1}^{\infty} z_k$ converges.

Example 3.27. Convergence and divergence.

a) $\sum_{k=1}^{\infty} \frac{i^k}{k^2 + i}$ converges since

$$\begin{aligned} \left| \frac{i^k}{k^2 + i} \right| &= \left| \frac{i^k}{k^2 + i} \cdot \frac{k^2 - i}{k^2 - i} \right| = \left| \frac{k^2 i^k - i^{k+1}}{k^4 + 1} \right| \\ &= \sqrt{\left(\frac{k^2}{k^4 + 1} \right)^2 + \left(\frac{1}{k^4 + 1} \right)^2} = \frac{1}{\sqrt{k^4 + 1}} \end{aligned}$$

and since $\sum_{k=1}^{\infty} \frac{1}{\sqrt{k^4 + 1}}$ converges.

b) $\sum_{k=1}^{\infty} \frac{1}{k + i}$ diverges, since

$$\frac{1}{k + i} = \frac{k - i}{k^2 + 1}, \text{ which implies that } \sum_{k=1}^{\infty} \operatorname{Re} \left(\frac{1}{k + i} \right) \text{ diverges.} \quad \blacksquare$$

Classification of Sets in the Complex Plane. We give some definitions relating to planar sets. $D(z_0; r)$ denotes the open disc of radius $r > 0$ centered at z_0 ; i.e., $D(z_0; r) = \{z : |z - z_0| < r\}$.

$D(z_0; r)$ is also called a neighborhood (or r -neighborhood) of z_0 .

$C(z_0; r)$ is the circle of radius $r > 0$ centered at z_0 .

A set S is said to be open if for any $z \in S$, there exists $\delta > 0$ such that $D(z; \delta) \subset S$.

$\tilde{S} = \mathbb{C} \setminus S$ denotes the complement of the set S ; i.e., $\tilde{S} = \{z \in \mathbb{C} : z \notin S\}$.

A set is a closed set if its complement is open. Equivalently, S is closed if $\{z_n\} \subset S$ and $z_n \rightarrow z$ imply $z \in S$.

∂S , the boundary of S , is defined as the set of points whose δ -neighborhoods have a nonempty intersection with both S and \tilde{S} , for every $\delta > 0$.

\bar{S} , the closure of S , is given by $\bar{S} = S \cup \partial S$.

S is bounded if it is contained in $D(0; M)$ for some $M > 0$.

Sets that are closed and bounded are called compact.

S is said to be disconnected if there exist two disjoint open sets A and B whose union contains S while neither A nor B alone contains S . If S is not disconnected, it is called connected.

$[z_1, z_2]$ denotes the line segment with endpoints z_1 and z_2 .

A polygonal line is a finite union of line segments of the form

$$[z_0, z_1] \cup [z_1, z_2] \cup \cdots \cup [z_{n-1}, z_n].$$

If any two points of S can be connected by a polygonal line contained in S , S is said to be polygonally connected.

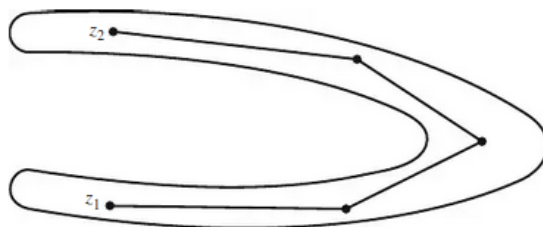

Figure 3.12: A polygonally connected set.

It can be shown that a polygonally connected set is connected. The converse, however, is false. For example, the set of points $z = x + iy$ with $y = x^2$ is clearly connected but is not polygonally connected since the set contains no straight line segments. In fact there are even connected sets whose points cannot be connected to one another by any curve in the set. On the other hand, for open sets, connectedness and polygonal connectedness are equivalent.

Definition 3.3. An open connected set will be called a region.

Proposition 3.2. A region S is polygonally connected.

Proof. Suppose S is an open connected set and $z_0 \in S$. Let A be an open subset of points of S which can be polygonally connected to z_0 in S . Since A is open any point z_0 in A can be polygonally connected to any other point in $D(z_0; \delta_0)$ for some $\delta_0 > 0$. Now consider another point $z_1 \in S$ such that $D(z_0; \delta_0) \cap D(z_1; \delta_1)$ is nonempty for some $\delta_0, \delta_1 > 0$. Clearly z_1 can be polygonally connected to z_0 and, in fact, any point in $D(z_1; \delta_1)$ can be polygonally connected to any point in $D(z_0; \delta_0)$. Continuing this chain of intersections to include all points of S , we conclude $A = S$ and S is polygonally connected. Since every point in S can be polygonally connected to an arbitrary z_0 , every pair of points can be polygonally connected to each other in S . \square

Continuous Functions.

Definition 3.4. A complex valued function $f(z)$ defined in a neighborhood of z_0 is continuous at z_0 if $z_n \rightarrow z_0$ implies that $f(z_n) \rightarrow f(z_0)$. Alternatively, f is continuous at z_0 if for each $\epsilon > 0$ there is some $\delta > 0$ such that $|z - z_0| < \delta$ implies that $|f(z) - f(z_0)| < \epsilon$. f is continuous in a domain D if for each sequence $\{z_n\} \subset D$ and $z \in D$ such that $z_n \rightarrow z$, we have $f(z_n) \rightarrow f(z)$.

If we split f into its real and imaginary parts

$$f(z) = f(x, y) = u(x, y) + iv(x, y),$$

where u and v are real-valued, it is clear that f is continuous if and only if u and v are continuous functions of (x, y) . Thus, for example, any polynomial

$$P(x, y) = \sum_{j=1}^n \sum_{k=1}^n a_{jk} x^k y^j$$

is continuous in the whole plane. Similarly

$$\frac{1}{z} = \frac{x}{x^2 + y^2} - i \frac{y}{x^2 + y^2}$$

is continuous in the "punctured plane" $\{z : z \neq 0\}$. It follows also that the sum, product and quotient (with nonzero denominator) of continuous functions are continuous.

We say $f \in C^n$ if the real and imaginary parts of f both have continuous partial derivatives of the n -th order.

A sequence of functions $\{f_n\}$ converges to f uniformly in D if for each $\epsilon > 0$, there is an $N > 0$ such that $n > N$ implies $|f_n(z) - f(z)| < \epsilon$ for all $z \in D$. Again, by referring to the real and imaginary parts of $\{f_n\}$, it is clear that the uniform limit of continuous functions is continuous.

Theorem 3.1. M-Test

Suppose f_k is continuous in D , $k = 1, 2, \dots$. If $|f_k(z)| \leq M_k$ throughout D and if $\sum_{k=1}^{\infty} M_k$ converges, then $\sum_{k=1}^{\infty} f_k(z)$ converges to a function f which is continuous in D .

Proof. The convergence of $\sum_{k=1}^{\infty} f_k(z)$ is immediate. Moreover, for each $\epsilon > 0$, we can choose N so that

$$\left| f(z) - \sum_{k=1}^n f_k(z) \right| = \left| \sum_{k=n+1}^{\infty} f_k(z) \right| \leq M_{n+1} + M_{n+2} + \dots < \epsilon$$

for $n \geq N$. Hence the convergence is uniform and f is continuous. \square

Example 3.28. $f(z) = \sum_{k=1}^{\infty} kz^k$ is continuous in $D : |z| \leq \frac{1}{2}$ since

$$|kz^k| \leq \frac{k}{2^k} \text{ in } D \text{ and } \sum_{k=1}^{\infty} \frac{k}{2^k} \text{ converges.} \quad \blacksquare$$

A continuous function maps compact/connected sets into compact/connected sets. None of the other properties listed above, though, are preserved under continuous mappings. For example, $f(z) = \operatorname{Re} z$ maps the open set \mathbb{C} into the real line which is not open. The function $g(z) = 1/z$ maps the bounded set: $0 < |z| < 1$ onto the unbounded set: $|z| > 1$.

Most of the key results in subsequent chapters will concern properties of a certain class of functions defined on a region. We note that we could

show that any two points in a region can be connected by a polygonal line containing only horizontal and vertical line segments. For future reference we will introduce the term "polygonal path" to denote such a polygonal line.

Theorem 3.2. Suppose $u(x, y)$ has partial derivatives u_x and u_y that vanish at every point of a region D . Then u is constant in D .

Proof. Let (x_1, y_1) and (x_2, y_2) be two points of D . Then they can be connected by a polygonal path that is contained in D . Any two successive vertices of the path represent the end-points of a horizontal or vertical segment. Hence, by the Mean-Value Theorem, the change in u between these vertices is given by the value of a partial derivative of u somewhere between the end-points times the difference in the non-identical coordinates of the end-points. Since, however, u_x and u_y both vanish in D , the change in u is 0 between each pair of successive vertices; hence $u(x_1, y_1) = u(x_2, y_2)$. \square

3.9 Stereographic Projection; The Point at Infinity

The complex numbers can also be represented by the points on the surface of a punctured sphere. Let

$$\Sigma = \left\{ (\xi, \eta, \zeta) : \xi^2 + \eta^2 + \left(\zeta - \frac{1}{2}\right)^2 = \frac{1}{4} \right\}; \quad (3.17)$$

that is, let Σ be the sphere in Euclidean (ξ, η, ζ) space with distance $\frac{1}{2}$ from $(0, 0, \frac{1}{2})$. Suppose, moreover, that the plane $\zeta = 0$ coincides with the complex plane \mathbb{C} , and that the ξ and η axes are the x and y axes, respectively. To each $(\xi, \eta, \zeta) \in \Sigma$ we associate the complex number z where the ray from $(0, 0, 1)$ through (ξ, η, ζ) intersects \mathbb{C} . This establishes a 1-1 correspondence, known as a stereographic projection, between \mathbb{C} and the points of Σ other than $(0, 0, 1)$.

Formulas governing this correspondence can be derived as follows. Since $(0, 0, 1)$, (ξ, η, ζ) and $(x, y, 0)$ are collinear,

$$\frac{x}{\xi} = \frac{y}{\eta} = \frac{1}{1 - \zeta}$$

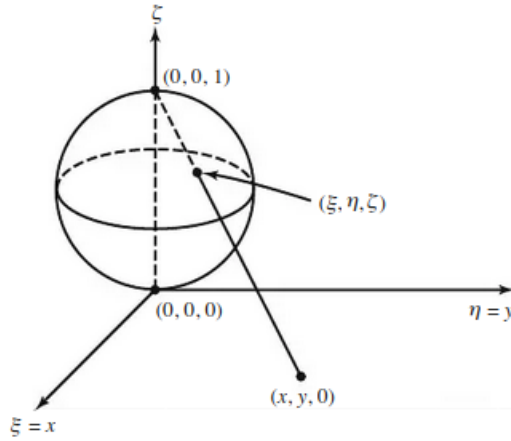

Figure 3.13: The Riemann sphere and stereographic projection.

so that

$$x = \frac{\xi}{1 - \zeta}; \quad y = \frac{\eta}{1 - \zeta} \quad (3.18)$$

The equations 3.17 and 3.18 can be solved for ξ, η, ζ in terms of x, y as follows. By substitution we solve for ζ ,

$$\begin{aligned} x^2(1 - \zeta)^2 + y^2(1 - \zeta)^2 + \left(\zeta - \frac{1}{2}\right)^2 &= \frac{1}{4} \\ x^2(1 - \zeta)^2 + y^2(1 - \zeta)^2 + \left(\zeta^2 - \zeta + \frac{1}{4}\right) &= \frac{1}{4} \\ x^2 + y^2 + \frac{\zeta(\zeta - 1)}{(1 - \zeta)^2} &= 0 \\ \frac{\zeta(\zeta - 1)}{(1 - \zeta)^2} &= -x^2 - y^2 \\ \frac{\zeta(1 - \zeta)}{(1 - \zeta)^2} &= x^2 + y^2 \\ \frac{\zeta}{1 - \zeta} &= x^2 + y^2 \end{aligned} \quad (3.19)$$

Now it is a fact that

$$\frac{\frac{x^2+y^2}{x^2+y^2+1}}{1 - \frac{x^2+y^2}{x^2+y^2+1}} = x^2 + y^2$$

So therefore,

$$\begin{aligned}\zeta &= \frac{x^2 + y^2}{x^2 + y^2 + 1} \\ \xi &= x(1 - \zeta) = \frac{x}{x^2 + y^2 + 1} \\ \eta &= y(1 - \zeta) = \frac{y}{x^2 + y^2 + 1}.\end{aligned}\tag{3.20}$$

Now suppose that $\{\sigma_k\} = \{(\xi_k, \eta_k, \zeta_k)\}$ is a sequence of points of Σ which converges to $(0, 0, 1)$ and let $\{z_k\}$ be the corresponding sequence in \mathbb{C} . By 3.18 and 3.19,

$$x^2 + y^2 = \frac{\xi^2 + \eta^2}{(1 - \zeta)^2} = \frac{\zeta}{1 - \zeta},$$

so that as $\sigma_k \rightarrow (0, 0, 1)$, $|z_k| \rightarrow \infty$. Conversely, it follows from 3.20 that if $|z_k| \rightarrow \infty$, $\sigma_k \rightarrow (0, 0, 1)$.

Loosely speaking, this suggests that the point $(0, 0, 1)$ on Σ corresponds to ∞ in the complex plane. We can make this more precise by formally adjoining to \mathbb{C} a "point at infinity" and defining its neighborhoods as the sets in \mathbb{C} corresponding to the spherical neighborhoods of $(0, 0, 1)$. While we will not examine the resulting "extended plane" in greater detail, we will adopt the following convention.

Definition 3.5. We say $\{z_k\} \rightarrow \infty$ if $|z_k| \rightarrow \infty$, i.e., $|z_k| \rightarrow \infty$ if for any $M > 0$, there exists an integer N such that $k > N$ implies $|z_k| > M$. Similarly, we say $f(z) \rightarrow \infty$ if $|f(z)| \rightarrow \infty$.

For future reference, we note the connection between circles on Σ and circles in \mathbb{C} . By a circle on Σ , we mean the intersection of Σ with a plane of the form $A\xi + B\eta + C\zeta = D$. According to 3.20, if S is such a circle and T is the corresponding set in \mathbb{C} ,

$$Ax + By + C(x^2 + y^2) = D(x^2 + y^2 + 1)$$

or

$$(C - D)(x^2 + y^2) + Ax + By = D \quad (3.21)$$

for $(x, y) \in T$. Note that if $C \neq D$, 3.21 is the equation of a circle. If $C = D$, 3.21 represents a line. Since $C = D$ if and only if S intersects $(0, 0, 1)$, we have the following proposition.

Proposition 3.3. Let S be a circle on Σ and let T be its projection on \mathbb{C} . Then

- If S contains $(0, 0, 1)$, T is a line;
- If S does not contain $(0, 0, 1)$, T is a circle.

Proof. Plugging $(0, 0, 1)$ into $A\xi + B\eta + C\zeta = D$ yields $C = D$ so eqn. 3.21 becomes the equation of a line which is equivalent to a circle of infinite radius. If S does not contain $(0, 0, 1)$, $C \neq D$ and eqn. 3.21 becomes the equation of a circle. \square

3.10 Curves and Regions in the Complex Plane

Circles and disks. The distance between two points z and a is $|z - a|$. Hence a circle C of radius ρ and center at a can be given by

$$|z - a| = \rho \quad (3.22)$$

In particular, the unit circle, that is, the circle of radius 1 and center at the origin $a = 0$, is

$$|z| = 1.$$

Furthermore, the inequality

$$|z - a| < \rho \quad (3.23)$$

holds for every point z inside C ; that is 3.23 represents the interior of C . Such a region is called a circular disk, or, more precisely, an open circular disk, in contrast to the closed circular disk

$$|z - a| \leq \rho,$$

which consists of the interior of C and C itself. The open circular disk 3.23 is also called a neighborhood of the point a .

Obviously, a has infinitely many such neighborhoods, each corresponding to a certain value of $\rho > 0$, and a is a point of each such neighborhood.

Similarly, the inequality

$$|z - a| > \rho$$

represents the exterior of the circle C . Furthermore, the region between two concentric circles of radii ρ_1 and $\rho_2 (> \rho_1)$ can be given by

$$\rho_1 < |z - a| < \rho_2,$$

where a is the center of the circles. Such a region is called an open circular ring or open annulus.

Example 3.29. $|z - 3 + i| \leq 4$ is valid for all z whose distance from $a = 3 - i$ does not exceed 4. Hence this is a closed circular disk of radius 4 with center at $3 - i$. ■

Half planes. By the (open) upper half-plane we mean the set of all points $z = x + iy$ such that $y > 0$. Similarly, the condition $y < 0$ defines the lower half-plane, $x > 0$ the right half-plane, and $x < 0$ the left half-plane.

Example 3.30. Determine the sets represented.

a) $|z - 4i| = 4$

Circle, radius 4, center $4i$.

b) $\frac{1}{3} < |z - a| < 6$

Annulus with center a .

c) $0 < \operatorname{Re} z < \pi/2$

Vertical infinite strip.

d) $|z - 1| \leq |z + 1|$

Right half-plane.

■

3.11 Exercises

1. Express in the form $a + bi$.
 - a. $\frac{1}{6 + 2i}$
 - b. $\frac{(2 + i)(3 + 2i)}{1 - i}$
 - c. $\left(-\frac{1}{2} + i\frac{\sqrt{3}}{2}\right)^4$
 - d. i^2, i^3, i^4, i^5

2. Find (in rectangular form) the two values of $\sqrt{-8 + 6i}$.

3. Solve the equation $z^2 + \sqrt{32}iz - 6i = 0$.

4. Prove the following identities:
 - a. $\overline{z_1 + z_2} = \overline{z_1} + \overline{z_2}$.
 - b. $\overline{z_1 z_2} = \overline{z_1} \cdot \overline{z_2}$.
 - c. $\overline{P(z)} = P(\overline{z})$, for any polynomial P with real coefficients.
 - d. $\overline{\overline{z}} = z$.

5. Suppose P is a polynomial with real coefficients. Show that $P(z) = 0$ if and only if $P(\overline{z}) = 0$ (i.e., zeros of real polynomials come in conjugate pairs).

6. Verify that $|z^2| = |z|^2$ using rectangular coordinates and then using polar coordinates.

7. Show
 - a. $|z^n| = |z|^n$.
 - b. $|z|^2 = z\overline{z}$.
 - c. $|\operatorname{Re} z|, |\operatorname{Im} z| \leq |z| \leq |\operatorname{Re} z| + |\operatorname{Im} z|$
(when is equality possible?)

8. a. Fill in the details of the following proof of the triangle inequality:

$$\begin{aligned}
 |z_1 + z_2|^2 &= (z_1 + z_2)(\overline{z_1} + \overline{z_2}) \\
 &= |z_1|^2 + |z_2|^2 + z_1\overline{z_2} + \overline{z_1}z_2 \\
 &= |z_1|^2 + |z_2|^2 + 2\operatorname{Re}(z_1\overline{z_2}) \\
 &\leq |z_1|^2 + |z_2|^2 + 2|z_1||z_2| \\
 &= (|z_1| + |z_2|)^2.
 \end{aligned}$$

- b. When can equality occur?
 c. Show: $|z_1 - z_2| \geq |z_1| - |z_2|$.
9. It is an interesting fact that a product of two sums of squares is itself a sum of squares. For example,

$$(1^2 + 2^2)(3^2 + 4^2) = 125 = 5^2 + 10^2 = 2^2 + 11^2.$$

- a. Prove the result using complex algebra. That is, show that for any two pairs of integers, $\{a, b\}$ and $\{c, d\}$, we can find integers u, v with

$$(a^2 + b^2)(c^2 + d^2) = u^2 + v^2$$

- b. Show that, if a, b, c, d are all nonzero and at least one of the sets $\{a^2, b^2\}$ and $\{c^2, d^2\}$ consist of distinct positive integers, then we can find u^2, v^2 as above with u^2 and v^2 both positive.
 c. Show that, if a, b, c, d are all nonzero and both of the sets $\{a^2, b^2\}$ and $\{c^2, d^2\}$ consist of distinct positive integers, then there are two different sets $\{u^2, v^2\}$ and $\{s^2, t^2\}$ with

$$(a^2 + b^2)(c^2 + d^2) = u^2 + v^2 = s^2 + t^2.$$

- d. Give a geometric interpretation and proof of the results in b) and c) above.
10. Prove: $|z_1 + z_2|^2 + |z_1 - z_2|^2 = 2(|z_1|^2 + |z_2|^2)$ and interpret the result geometrically.
11. Let $z = x + iy$. Explain the connection between $\operatorname{Arg} z$ and $\tan^{-1}(y/x)$. (Warning: they are not identical.)

12. Solve the following equations in polar form and locate the roots in the complex plane:

a. $z^6 = 1$.

b. $z^4 = -1$.

c. $z^4 = -1 + \sqrt{3}i$.

13. Show that the n -th roots of 1 (aside from 1) satisfy the "cyclotomic" equation $z^{n-1} + z^{n-2} + \cdots + z + 1 = 0$. [Hint: Use the identity $z^n - 1 = (z - 1)(z^{n-1} + z^{n-2} + \cdots + 1)$.]

14. Suppose we consider the $n - 1$ diagonals of a regular n -gon inscribed in a unit circle obtained by connecting one vertex with all the others. Show that the product of their lengths is n . [Hint: Let the vertices all be connected to 1 and apply the previous exercise.]

15. Describe the sets whose points satisfy the following relations. Which of the sets are regions?

a. $|z - i| \leq 1$.

b. $\left| \frac{z - 1}{z + 1} \right| = 1$.

c. $|z - 2| > |z - 3|$.

d. $|z| < 1$ and $\text{Im } z > 0$.

e. $\frac{1}{z} = \bar{z}$.

f. $|z|^2 = \text{Im } z$.

g. $|z^2 - 1| < 1$. [Hint: Use polar coordinates.]

16. Identify the set of points which satisfy

a. $|z| = \text{Re } z + 1$.

b. $|z - 1| + |z + 1| = 4$.

c. $z^{n-1} = \bar{z}$.

17. Let $\text{Arg } w$ denote that value of the argument between $-\pi$ and π (inclusive). Show that

$$\text{Arg} \left(\frac{z-1}{z+1} \right) = \begin{cases} \pi/2 & \text{if } \text{Im } z > 0 \\ -\pi/2 & \text{if } \text{Im } z < 0 \end{cases}$$

where z is a point on the unit circle $|z| = 1$.

18. Find the three roots of $x^3 - 6x = 4$ by finding the three real-valued possibilities for $\sqrt[3]{2+2i} + \sqrt[3]{2-2i}$. (Note: You can find the three cube roots of $2+2i$, or you can simplify the problem by first applying the identity: $a+b = (a^3+b^3)/(a^2-ab+b^2)$).
19. Prove that $x^3 + px = q$ has three real roots if and only if $4p^3 < -27q^2$. (Hint: Find the local minimum and local maximum values of $x^3 + px - q$.)
20. a. Let $P(z) = 1 + 2z + 3z^2 + \cdots + nz^{n-1}$. By considering $(1-z)P(z)$, show that all the zeros of $P(z)$ are inside the unit disc.
- b. Show that the same conclusion applies to any polynomial of the form: $a_0 + a_1z + a_2z^2 + \cdots + a_nz^n$, with all a_i real and $0 \leq a_0 \leq a_1 \leq \cdots \leq a_n$.
21. Show that
- a. $f(z) = \sum_{k=0}^{\infty} kz^k$ is continuous in $|z| < 1$.
- b. $g(z) = \sum_{k=1}^{\infty} 1/(k^2 + z)$ is continuous in the right half-plane $\text{Re } z > 0$.
22. Prove that a polygonally connected set is connected.

23. Let

$$S = \left\{ x + iy : x = 0 \text{ or } x > 0, y = \sin \frac{1}{x} \right\}.$$

Show that S is connected, even though there are points in S that cannot be connected by any curve in S .

24. Let $S = \{(\xi, \eta, \zeta) \in \Sigma : \zeta \geq \zeta_0\}$ where $0 < \zeta_0 < 1$ and let T be the corresponding set in \mathbb{C} . Show that T is the exterior of a circle centered at 0.

25. Suppose $T \subset \mathbb{C}$. Show that the corresponding set $S \subset \Sigma$ is
- a circle if T is a circle.
 - a circle minus $(0, 0, 1)$ if T is a line.
26. Let P be a nonconstant polynomial in z . Show that $P(z) \rightarrow \infty$ as $z \rightarrow \infty$.
27. Suppose that z is the stereographic projection of (ξ, η, ζ) and $1/z$ is the projection of (ξ', η', ζ') .
- Show that $(\xi', \eta', \zeta') = (\xi, -\eta, 1 - \zeta)$.
 - Show that the function $1/z$, $z \in \mathbb{C}$, is represented on Σ by a 180° rotation about the diameter with endpoints $(-\frac{1}{2}, 0, \frac{1}{2})$ and $(\frac{1}{2}, 0, \frac{1}{2})$.
28. Use exercise (27) to show that $f(z) = 1/z$ maps circles and lines in \mathbb{C} onto other circles and lines.

