

# ON CONSTANCY OF LIGHT VELOCITY IN ALL SUBSTANCES

José J. Astorkia

## ABSTRACT

Review of Foucault experiment of 1850 shows that it not probes value of velocity of light in water. Review of experimental facts until now does plausible that velocity of light transmisión were the same in all material media, same like in vacuum. This supposition is in better agreement with current matter standard model.

## INTRODUCTION

Later than the atom model of Rutherford we know that all the substances are mostly empty space and that the matter, the atoms, occupies a very small part of the space. And the logical deduction would have to be that any ray of light that crosses it has moved in the vacuum between atoms. Therefore the light must move in any substance at the same speed that in the vacuum.

On the other hand the standard model says that the light velocity in the matter is smaller than its velocity in the vacuum. These velocities are related to the refractive index of these substances. Model affirms that this is based on experimental evidences and point to the experiment of Foucault in 1850 comparing the speed of the light travelling in the air and in the water.

In this paper we examine this issue. In first section we compare the differences in the standard models about the matter in XIX century and XXI century, and the predictions on the consequent behavior of the light in those models. In the second section we review the experiment of Foucault (1850) habitually mentioned as evidence of lights speed in water, and the validity of declared conclusions. In a third section we look for other experiments that can serve as evidences about this issue. In the last section we present the conclusions that we can deduce about all it.

## LIGHT VELOCITY IN MATTER

Towards 1850 it was considered that the matter had porous character, with great hollows between its smallest particles, with one distinction according to model of light used, there was ether filling pores according to the undulatory model but they were empty space according to the model of light like particles.

The model of the light with particles denominated then theory of emission is described in Opticks by Isaac Newton. It considers that in any substance there is much more empty space that space occupied by particles of that substance. Which allows that the smallest particles that form the ray of light can move from the source to the eye crossing idle space in vacuum or transparent matter. And it proposes that the refraction of the light between two different substances is caused by changes in velocity of light due not identified interaction at distance that gives additional impulse to light particles and it supposes is approximately proportional to the density of the matter, reason why it considers that the light moves faster when substance

is more dense, and that light velocity is faster moving in any substance than crossing the vacuum.

The undulatory model of the light described in Treatise of light by Christian Huygens and at that time it was better accepted by the majority after its defense, and attacks to model of emission, by Thomas Young in the early century by lectures in the Royal Society of London. In this case it is not contemplated to the material displacement from light source to eye but the transport of energy by a wave. Since it were known that the waves are not transmitted without an substance that it support wave by the proven example of the sound, that is not transmitted in the vacuum, was necessary to postulate that the vacuum was full of a strange matter that interact strong with the light waves but interact much lesser with the common matter, to which was denominated ether. In this case it is considered that in all substances the light moves more slowly than through ether because the particles of the matter impede by some indetermine process the movement ability of ether particles that would slow down the displacement speed of the light waves. In fact it is the difference of speed of transmission of the light in two different matters the cause of refraction, changing direction of the ray of light when pass from a substance to another. It supposes that refraction index depends of the ratio of different velocities of the light in an matter and in the other.

In century XXI the model for the matter is already similar to noted above but with more extreme ratio between empty space and space occupied by matter particles. But it has changed in many senses in the characteristics of the light. The character of the light is considered dual, as much wave as particle. The movement of the light across empty space is accepted denying the necessity of ether. Specially it is considered that the speed of the light is constant without influence of the character or frequency of light, of the character or conditions of movement or not of the emitter or the receiver, or gravitational or expansive conditions of the space that crosses, existing an only exception. By some mechanism unknown that I can not to find candidates postulated in literature, the existence of matter in the proximities of the trajectory of the light beam causes that it changes its speed of propagation drastically in dependence with type and amount of matter present. This affirmation of the standard model is due to the experimental evidence and recalls as initial evidence to the experiment of 1850 of Foucault of measurement of the speed of the light in the air and the water.

It seems important to determine what can cause that effect. It cannot be direct interaction between photons and atoms, in which case happens the capture of the photon and its energy or its dispersion in other direction. Since a light beam is a great set of independent photon that they have in common his successive or synchronized step over small area of the space with the same direction, these photons that react cannot be in the salient beam. The light ray that leaves a section of certain transparent matter is the portion of the photons of the incoming light ray that have crossed this matter continuously by vacuum and which we can suppose successive or simultaneous due all they travel with the same speed, that is to say, the speed of the light in the vacuum, whatever be that matter. And an indirect and common interaction of atoms of the matter with all photons so that they move synchronous with some different speed is hard to imagine. It is easier to imagine refraction of the light caused by the shape of the space in a certain place and independent of the speed of photons.

The greater change of the model of the universe with the mentioned above is the character of space, that instead of being exclusively three-dimensional now is considered with four dimensions. This fourth dimension is deformed by influence of the present matter and, as well, this shape changes the direction of matter motion initially straight, being that we call gravity. In the matter in motion that can be scattered we must include photons, specially when are crossing from space containing an material to space containing other substance, from space of shape caused by determined conditions of matter present to space shaped by others conditions, amount and type of matter. This space is continuous and it must change from a shape to other in a very short length in the space of three dimensions, which predicts in the fourth dimension a step or deformation with few height but, able to deflect the photons that cross it. It will suffered more or less scattering depending deformation slope, that must depends of present matter density and/or another feature. Scattering that will be greater whichever greater is the angle of the trajectory with respect to the normal to the surface between both matter.

But although it is possible to search for modern explanations, does not have sense to try it if the evidences already prove the mechanisms today proposed, even tough so paradoxical than they can be. For that reason we must first to compile and to review those evidences

#### **FOUCAULT'S EXPERIMENT OF 1850**

The evidence that is first mentioned on this question is the experiment of Foucault of 1850 comparing the velocity of the light through air, on the one hand, and with part of its trajectory across the water, by another one. This experiment is detailed in doctoral thesis that Foucault presented in 1853, see for to know aim, performance and results.

That paper shows that experiment aim is to determine which is the return images more deviated from both, for wich it does not need to measure the absolute deviation of each one of them with respect to the theoretical value for light across vacuum. I believe that we would have to affirm that is totally motiveless the affirmation "the deviations are sensibly proportional to the refractive index" due by Foucault in this paper when it is clear that it has not measured the absolute value of those deviations, by design and performance of experiment.

Figure 1 shows with black lines the assembly of cited experiment with the same denomination for all its parts. Thus we can see that the author has neglected an important difference between both path for the light that he considers. The lens  $L'$  is only in the path to  $M'$  mirror that has part of the way through water, and is not in the way to  $M$  mirror. We know that a lens changes the size of the image, and even can change its position in the visor, then we cannot to compare two images that are not similar. This puts in doubt all the conclusions that Foucault had expose in cited paper.

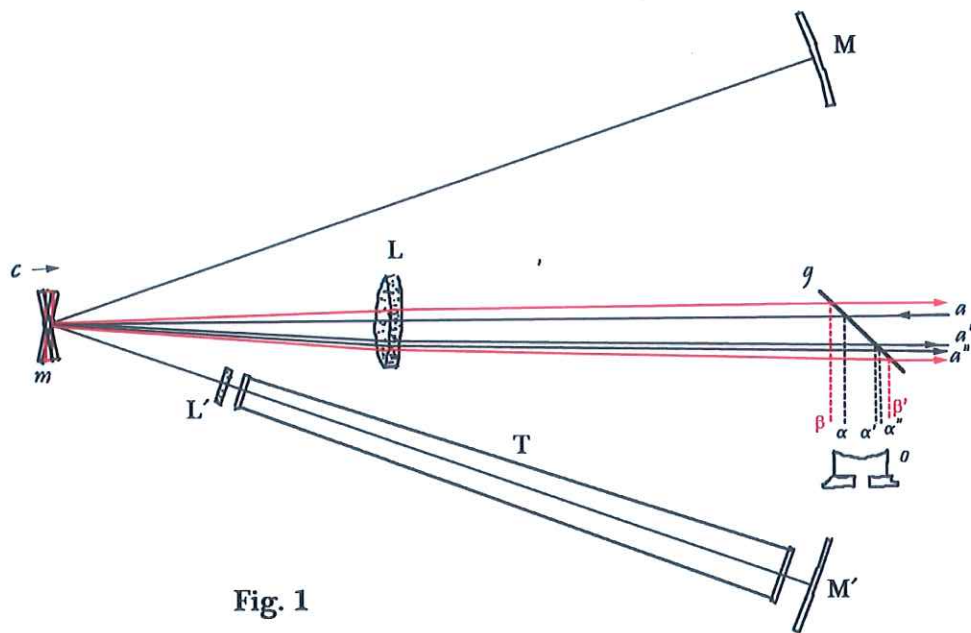

Fig. 1

We must add that he neglected a route in which the light is reflected direct from rotatory mirror to visor, to objective. That position is showed in figure 1 in red, and is near around the perpendicular to the ray of incident light. This reflection is not a fixed image like when a fixed mirror is add in the route. The image is a continuous slide in full wide of the objective. And it allows us to understand the function of the lenses L and L', selected probably empirically and without clear understanding of its influence. Lens L with the indicated focal length concentrates all the reflection of total weight of rotatory mirror in one thin trace at center of objective, is the narrow shining strip that Foucault describes in his paper, that will occupy all wide of the visor and in which we cannot see the shade marking center of light emitter due image is not fixed and move this shade across full visor for each mirror turn. This added to image size change that causes L' lense, allows to see the fixed image that return from M' up and down from centered narrow shining strip. But the light that arrives from fixed mirror M at the rotatory mirror, very debilitated by the great masked surface and without L' lens effect is concentrated in centered shining strip by lens L, and it cannot be distinguished of "the direct" reflection "contamination", which prevents any comparison between images and disqualifies all Foucault's conclusions.

It seems evident that Foucault did not get to see where was the problem because a simple solution is evident with a small modification of the assembly. It is to maintain objective L, for reduce the area "contaminated" in the objective by the direct reflection, including also a lens like L' and in same position in way from M, for recovery symmetry that allows the comparison of the images of both "fixed" trajectories, and same time modifies the size of the image that comes from M and it extends it outside "the contaminated" area. We can then mask different zones in the mirrors M and M', superior half in one and inferior half in another and then we

can see two “gray images” in the objective (following Foucault’s description in cited paper) that we can compare, one over the shining strip and another one below it.

But actual experiment performance imply that exposed conclusions are not, nor they can be, proven and they are simple speculation.

### **SEARCHING FOR ANOTHERS EXPERIMENTS**

We try search for other experiments that can be evidence on this question. In Literature we find many measurements of the speed of the light but all they have in common that they have been made in routes of the light across air or across vacuum. Their results are very near in both cases and in any case the difference between values in both media is quantified. They do not probe nothing on this question.

Have been two information of measurement of the absolute value of the speed of the light in the water or another means different from the air, aside from the experiment of Foucault analyzed in the previous paragraph. First it is the experiment of Fizeau to compare the speed of the light in the air and the water that it has in common with previous the year of accomplishment (1850) and the method with use of the rotating mirror. There is another later one but in that same century of Gutton in order to measure the speed of the light in a refringente liquid. In both cases the information is little and the detailed results of the experiment do not occur. Between the references of paper of Gutton two information are mentioned more, “Michelson, Sur la vitesse de propagation de la lumière blanche et colorée dans l’air, l’eau et le sulfure de carbone (Astron. Papers for de use of the Amer. Ephemeris, p.235; 1885)” and Gouy, Sur la vitesse de la lumière dans le sulfure de carbone (C. R., t. CIII, p.244: 1886)”, that I have not been able to recovery, not being able to find either no information or additional citation in spite of the evident notoriety of the authors.

Analyzing the little information available in both cases in which one has been we see that the experiment of Fizeau is similar to the one of Foucault and shares its problems agravated by its design whereas the experiment of Gutton is based on obsolete presumptions and the interpretation that does its results unacceptable today.

Fizeau does not inform into to have considered the direct reflection of the rotatory mirror in its perpendicular position to the light source, a little later in its experiment. Although it On guard has a lens similar to lens L of Foucault it does not inform into selection of its focal length, nor reports luminous strip horizontal in the viewfinder, nor speech of inclinations calibrated of the different mirrors to vertically separate that image of the static reflections. Also it shares the problem of the differences between the routes by different arms that are three in this case and difficult therefore the necessary calibration. Although in its report it indicates that the arms are different in length from a calculated form does not mention more difference. And if the figure of the assembly of this experiment that shows Lequeux in its biography of Fizeau is trustworthy it includes a lens in the arm of longer route by the absent air in other routes. Since we have said before we must wait for differences of size in the reflected images if it crosses a lens in a case and not in another one. In addition the design to this experiment presents/displays its own problems in the reading and interpretation of the results. It describes the reading of its results of the observation of three vertical strips. One first dark

strip to be in the shade of the prism in the assembly. A shining central strip where the three reflected images of the three different routes are superposed. And to the other side it locates without giving to dimensions another less shining strip there where to the images of the longest route by the air and the one of the arm are superposed that happens through water, but not the one of the short route by the air that turns aside less. We do not have the lengths to make an estimation but we can suppose that this strip has a wide one of 1 to 2 mm in spite of the greater speed of turn of the mirror in this experiment. To visualize a narrow strip enough brilliant differentiating it from another more shining strip with clearness turns out tremendously demanding with the calibrations to align the images reflected from the three different routes. Calibrations that have not been described.

Also a report would be desirable of how the result has been verified made public of so categorical form. Information that it does not give in that report. Because if we suppose that the result corresponds with the one of the emission theory the visible result is very similar. The strips lateral dark and central very shining continue being equal. And the narrow strip continues having same wide but now it only receives the light of the image of the arm of longer route through air. The criterion to discriminate the result seems to be to consider at first if the narrow strip has a luminosity of less than half or more than half of the shining reference that it has beside. My conclusion is that the results reported in this report are not of sufficient confidence like being able to consider them conclusive.

In the report of the experiment of Gutton it is described how the speed of the light is "measured" by means of light pulses that obtain polarizing the light that crosses a tube of a meter of length that contains a refringente liquid in an extreme and the other. For the calculation of the time it considers that the signal takes a time in arriving from the source until the extreme of the tube and designs a form to vary the length of the route to one of the extremes for adjustment. Nevertheless it considers that there is no time interval between the arrival of the electrical signal and the totally effective polarization of the light. It indicates that the concept of the experiment is basically incorrect due to the poor initial knowledge of very novel phenomena at that time, as also they indicate details because it specifies like sufficient for a sensible result a length of the tube of only a meter, or that it considers the speed of displacement of the electrical signal by the equal wire at the speed of the light in the vacuum, without having in consideration as is the material and very far from the later measured experimental values, more of a order of magnitude smaller. Given the poor information we cannot explain that it can be measuring in this experiment, but we can affirm categorically that it is not measuring the speed of the light.

## **CONCLUSIONS**

Briefly the conclusions that we can extract are the following ones.

The performance of Foucault of 1850 experiment can not measure the velocity of light across water. It is not either able to discriminate if this velocity is equal or different of the light velocity in the air.

We did not find report of other experiments that to be applicable on this question.



We do not know the speed the light in the matter experimentally. The values that the standard model gives are estimated from the not proved supposition that are relation between the light velocity in two different media and the refractive index.

That supposed relation does not have any mechanism of performance if we consider the description of the matter that makes the actual standard model now. And the deductible possibility of deformations of the space point to more logical mechanism for refraction fact.

Therefore is necessary a crucial experiment that measures the speed of the light in the water (or another appropriate substance) due there is not it today. And we will have to consider its results for following research.

## REFERENCES

Gutton C. Expériences sur la vitesse de la lumière dans les milieux réfringents. J. Phys. Theor. Appl., 1912, 2 (1), pp.196-203. .

<https://hal.archives-ouvertes.fr/jpa-00241741/document>

Fizeau, H & Breguet, L. Sur l'expérience relative à la vitesse comparative de la lumière dans l'air et dans l'eau (1850) CRAS 30, p. 771-774

<http://visualiseur.bnf.fr/CadresFenetre?O=NUMM-2987&M=pagination>

Fizeau, H. Sur les hypothèses relatives à l'éther lumineux, et sur une expérience qui paraît démontrer que le mouvement des corps change la vitesse avec laquelle la lumière se propage dans leur intérieur in Annales de chimie et de physique (1859), 3 , LVII

<https://gallica.bnf.fr/ark:/12148/bpt6k347981/f381.item>

Foucault, L. Sur les vitesses relatives de la lumière dans l'air et dans l'eau in Annales de chimie et de physique , 3 , XLI

<http://visualiseur.bnf.fr/ark:/12148/bpt6k34782n/f128>

Huygens, C. Treatise on Light The Project Gutenberg eBook #14725

Newton, I. Opticks ISBN:9786050407372

Rutherford, E. The Structure of the Atom Phil. Mag. 27, 488

Rutherford, E.(1911) 'LXXIX. The scattering of  $\alpha$  and  $\beta$  particles by matter and the structure of the atom', Philosophical Magazine Series 6, 21: 125, 669 — 688

Samueli, J-J Foucault and Measuring the Speed of Light in Water and in Air (2009)

<http://www.bibnum.education.fr/sites/default/files/37-foucault-analysis.pdf>

Young, T. I. The Bakerian Lecture. Experiments and calculations relative to physical optics. Phil. Trans. R. Soc. Lond. 1804 94, 1-16

<http://rstl.royalsocietypublishing.org/content/94/1.1>

Young, T. II. The Bakerian Lecture. On the Theory of Light and Colours

Phil. Trans. R. Soc. Lond. 1802 92, 12-48

<http://rstl.royalsocietypublishing.org/content/92/12>