

REPORT OF THE 14 MAY 2014 ACCIDENT AT THE KUDANKULAM NUCLEAR POWER PLANT

VT Padmanabhan,* R. Ramesh, V Pugazhendi,
Raminder Kaur, Joseph Makolil

Author affiliations

1. VT Padmanabhan,
Society of Science, Environment and Ethics, (So-SEE),
Karippat, Western Baazar, Aranattukara, Thrissur, Kerala, India -680616
- 2,3. Ramesh Radhakrishnan and V Pugazhendi,
Doctors for Safe Environment (DOSE), 78-3 Vinayagar Koil Street,
Kanuvai, Coimbatore, 641108, Tamil Nadu, India;
4. Raminder Kaur,
School of Global Studies, University of Sussex, Brighton BN1 9SJ, UK;
5. Joseph Makkolil,
Inter University Centre for Nanomaterials and Devices (IUCND),
Cochin University of Science and Technology, Kochi- 682022

Summary

An accident in which six workers received burn injuries, three of them severely, occurred on 14 May 2014 at the Kudankulam Nuclear Power Plant (KKNPP) which is under the last phase of commissioning in Tirunelveli district of Tamil Nadu, South India. The Press Information Bureau of the Government of India states that the reactor was on a maintenance shut down and that the workers were repairing a valve at the time of the accident at 12.10 on 14 May, 2014. According to the Southern Regional Load Distribution Centre (SRLDC), the reactor was on a forced shut down since 14.36 on 12 May due to tripping of the main feed-water pump. At the time of the accident, the reactor was critical, and hence no maintenance activity is possible. The incident on 14 May was in fact an accident in the feed-water pipeline. It is an irony of history that this accident began on 9 May 2014, a day after the Supreme Court of India “dismissed the petition to stall the commissioning of the plant, expressing satisfaction at the government’s steps towards safety measures.”¹

* Corresponding author: vtpadman@gmail.com

The Official Version of the Event

Six workers were injured at 12.10 on 14 May 2014 in an accident in the turbine building of KKNPP-1 reactor which is under C-3 commissioning phase. After giving first aid at the site, the survivors were rushed to the hospital in the township, 12 km away from the nuclear plant. From there they were shifted to an orthopedic hospital 4.5 km north-west of Nagercoil town and 42 km away from the Kudankulam Nuclear Power Plant (KKNPP). This hospital specializes in fractures and injuries and does not have a dedicated burns ward. Later on, based on the recommendation of medical experts from Madurai, two severely injured workers were shifted to a super-specialty hospital at Chennai, 825 km to the north. KKNPP Chief Medical Officer said they had suffered 20-70 per cent burns.

On 15 May, quoting anonymous sources inside the KKNPP, *The Hindu* reported that “operations in the first unit had been stopped for mandatory tests before increasing the generation to 1,000 MW(e), the maximum capacity, after the reactor reached 900 MW(e) a few days ago”.² In another report in the same newspaper, “when the routine maintenance work was going on, a valve in the turbine building was checked by three contract workers in the presence of KKNPP employees. As hot water stagnating in the valve chamber, whose temperature would range from 65 to 70 degrees Celsius, spilled suddenly from the valve as it was opened, all the six sustained small burns and were given first-aid.” It continued, “The sources denied rumors that there was an explosion in pipes carrying steam, and in the valve connected to these pipes.” “This is an ‘expected and listed event’ to caution the workers usually participating in the maintenance work of this nature”.³

According to the findings of the Atomic Energy Regulatory Board's (AERB) accident investigation dated 20 May 2014, the “incident of the hot water spillage leading to the hot water burn injuries to 6 workers was during maintenance of a 3-way hot water inlet valve to a heater loop in the turbine building of KKNPP-1 (which was under shutdown during the maintenance period) due to trapped hot water release. Water spilled over the persons during dismantling of the valve of 50 cm size. This was due to inadequate draining of the hot water before taking up the routine maintenance work on the valve. It is also concluded that there was no design deficiency with respect to the construction of the said valve.”⁴ Indeed the word ‘maintenance’ appears three times in the 181 worded AERB accident analysis report

Here we attempt to find out the facts behind the 14 May incident, using the data on power production and outages of KKNPP published by the Southern Regional Load Dispatch Centre

(SRLDC), Bangaluru.

The Health of the Reactor: Before and After the Event

We have accessed the SRLDC's daily reports of power supply position and generation outage. The former provides data for peak generation, time of peak generation, generation at 19.30 hrs and 0300 hrs, average generation for the day and units of electricity delivered (in million units) for all generating stations connected to the southern grid. The report on generation outage provides data on date and time of outage, cause of outage, expected date of revival and time and date of actual revival. The cause of outage and the expected date of revival are provided by the generating stations, while all other data are machine-generated.

Table 1 has data on day's peak generation and million units delivered during the period 08 May to 02 June 2014. Chart-1 is based on data of average MW(e) per day for the period 01 May to 26 May. Column 4 in table 1 shows the time of outage (left aligned) and time of revival (right aligned). The reactor was on a forced shut down since 14.36 on 12 May 14 due to the problems in the main feed-water pump.⁵

Generation and Outage 08 May to 31 May 2014

Date	Day peak MW(e)	Million Units	Time of outage/ Revival*
May 8, 14	860	18.9	
May 9, 14	864	15.6	
May 10, 14	550	11.63	
May 11, 14	568	11.63	
May 12, 14	562	6.5	14:36:
'May 13 & 14, 14	OUTAGE – 2 DAYS		
May 15, 14	349	0.66	16.23
May 16, 14	486	8.69	
May 17, 14	736	15.71	
May 18, 14	775	17.26	
May 19, 14	769		15.54
'May 20 to 26, 14	OUTAGE – 7 DAYS		
May 27, 14	316	0.57	17.38
May 28, 14	532	12.11	
May 29, 14	739	15.33	
May 30, 14	900	16.57	
'MAY 31 To Jun 2	OUTAGE 3 DAYS		21.11

Source : SRLDC daily reports

* Time of outage = left aligned
Time of revival = right aligned

KKNPP One - Generation before and after the Accident on 14 May 2014

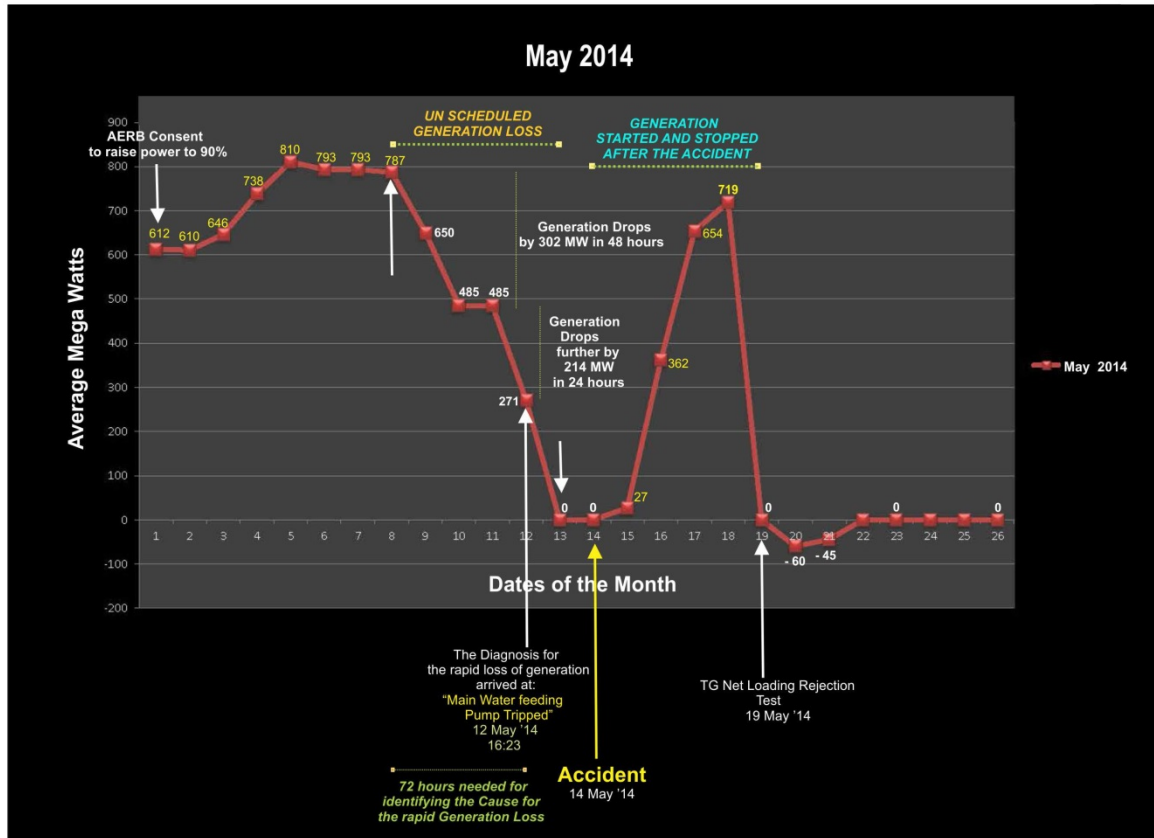

Data Source: www.srldc.org

Graph- 1: Daily data on average generation (MWe) and important events at KKNPP- 01 to 26 May 14.

The reactor remained off-grid till 16.23 on 15 May. A Press Trust of India (PTI) dispatch, filed at 14.55 on 14 May quotes the Station Director saying that the “Reactor No.1 attained criticality again today morning and continued to operate at low reactor power level. Steam supply to turbine and subsequent synchronization to the grid was planned for tomorrow”⁶. So at the time of the accident, the operators were trying to raise the power level and run the turbine. The reactor was *not under maintenance shutdown* and the workers were *not repairing* any valve.

COMMISSIONING OF A COMMERCIAL REACTOR

KKNPP-1 is the first Pressurized Water Reactor (PWR) of 1000 MW(e)(e) being built and commissioned in India. This is a split-contract in which the Russian agency, Atomsroyexport, supplied equipment and drawings and the Nuclear Power Corporation of India Limited (NPCIL) is

responsible for civil construction and commissioning. This is the first PWR being commissioned in India involving Indian scientists and engineers. This reactor is almost twice as large as Tarapur-3 designed, built and commissioned by Indians. For them, the commissioning of KKNPP is a First-Of-A-Kind (FOAK) event. Commissioning a big commercial reactor is almost like a planned military operation. Different systems and sub-systems within the reactor complex will have its own commissioning team and leaders. The commissioning crew consisting of scientists, engineers and technicians numbering around 500 personnel, is assembled well in advance of the actual work. Their first task is to prepare a plan in which each move will be described in detail in a language understood by all team members. The script will also include the time of start and the duration of tests, stoppages and hold points. All instructions given and actions taken would be recorded in writing and on film. During the commissioning, workers lower in the hierarchy are not authorised to perform any act on the system, without the explicit instructions by the leadership of the commissioning group.

The 14 May accident took place in the very sub-system that tripped on 12 May. As the reactor attained criticality in the morning, the entire commissioning team and the cameras would have been focusing on the pump that tripped and other vulnerable points within the feed-water subsystem.

Observations

1. Repairs and maintenance during criticality

Before taking the reactor to criticality, all the necessary repairs/maintenance should have been completed. After attaining criticality, coolant temperature rises slowly and it takes a minimum of 13 hours to generate enough steam to run the generator. (The Station Director said that generation will start the next day - that is, at least 10 hours later.) Until then, the low-pressure, low-temperature steam would travel through the bypass valve, avoiding the turbine, to the condenser and from there back to the steam generator. The six workers could not have been tinkering with a valve when the reactor was critical and gearing up towards power generation.

2. First degree burns treated in super-specialty hospitals

According to AERB's investigation, the workers received first degree burns that affect the epidermis, the outer layer of the skin. First degree burn victims are normally given first aid and sent home for rest. In this case, on the contrary, after receiving first aid, they were instead rushed to the KKNPP hospital. From there they were sent to another hospital 42 km away, at about 4.5 km from Nagercoil town, which specializes on fractures and injuries. Two injured persons were later shifted to a super-specialty hospital in Chennai. In all probability, they would have received third degree

burns along with other external and internal grievous injuries, that would have warranted their shifting, firstly, to an orthopedic hospital and, later, to the super-specialty hospital at Chennai. Hence, the version of events that state that the affected workers had received only first degree burns does not seem to be credible.

3. 70% burns from a spill from a 50 cm valve

According to the KKNPP's medical officer, the affected workers had received 20%-70% burns. That means, a few of them had their entire front (50.5%) or the back of their body (49.5%) burned along with almost half of the remaining side, which indicates that both the front and back portions of their bodies were in contact with the heat source. It is hard to believe that the spilling of stagnant water, 70 degree Celsius from a 50 cm valve could have caused this extent of injury to so many workers instantly. As the reactor has been critical for more than six hours before the accident, the temperature of water flowing into the high-pressure heater would be around 160 degree Celsius

4. Media blackout on the condition of the victims

The accident received wide media coverage in both the audio-visual and print media. However, apart from their names and ages, no details of the victims (Do were made available. In other lesser disasters, the coverage normally includes imagery of the victims and their grieving relatives including interviews with them along with other hospital staff. In this case, even the name of the Chennai super-specialty hospital where two seriously injured workers were treated is also unknown. The Nagercoil based orthopedic hospital has strong business ties with KKNPP as it received Rs 1.9 millions out of Rs 43 million medical bills paid by KKNPP during the past year. (Extracted from the weekly reports on work payments given at the website of NPCIL. A sample report can be seen here - http://www.npcil.nic.in/main/payments_pdf/KKNPP_2014_13_W_A.pdf)

To sum up, firstly, the official accident investigation team's observation that the unit was closed down for maintenance is not true. Secondly, the team's observation that the injured workers were doing maintenance work is also impossible, as the reactor was critical for more than six hours. Thirdly, the total skin surface area involved and the severity of injuries indicate that the causes of injuries could not have been '65-70 degree Celsius stagnant water spilling out from a valve'. Fourthly, the commissioning crew at KKNPP, which includes the best scientists and engineers with experience in the start-up operations of several other reactors like TAPS- 3&4 is highly unlikely to have relaxed the start-up protocol and left the critical reactor components with safety implications for a free ride by inexperienced and untrained workers.

What really could have happened?

In view of the inconsistencies in the story put out by AERB and NPCIL, could the news flashed by the television channels immediately after the accident that “there was an explosion in pipes carrying steam, and in the valve connected to these pipes” be true? As the workers were taken to an orthopedic hospital, 42 km away from KKNPP, and two of them shifted to a Chennai based super specialty hospital later, a pipe burst could have indeed happened at a spot between the deareator (an apparatus that removes trapped gases from the feed-water) and the high-pressure heater. Feed-water flowing at this point of the pipe is around 160 degree Celsius and of high-pressure. The hot water jet and missiles of metallic pipe pieces could have hit the workers, inflicting the workers who were in the line of sight with serious injuries and those others who were out of sight with minor burns. The accident could have forced another shut down of the reactor and delayed the electricity generation till 16.23 hrs next day.

Responding to the statement that the accident is an “expected and listed event to caution the workers usually participating in the maintenance work of this nature”, Dr Anisur Rahman, formerly with Atomic Energy Research Establishment (AERE); Bangladesh asks: “ Where are the Operating Procedures for the workers to operate in a safe environment and thereby avoid such incidences or accidents? Does the station work under any ‘Operating Procedures and Safety Rules’?”⁷ Fission technology has been with us for seven decades and there are the experiences of more than 12,000 reactor years. Today, there is no need to include practical sessions such as those cited on the 14 May accident in the curriculum for safe work in nuclear plants.

CONCLUSION

Before the 14 May accident, there were two events (on 29 Oct 2013⁸ and 12 May 2014⁹) related to feed-water system, leading to the shutdown of the reactor for 9 days. Another event on 30 May due to problems in the deareator, located on the feed-water system just before the spot of 14 May accident, took the reactor off line for 4 days. (See figure-1) Again, four days after this accident, there was another outage, lasting for 8 days.¹⁰ The cause of this outage, according to SRLDC was net load rejection test. Load rejection test can only be conducted when the generator is grid connected and this test is completed in a few hours. So the actual cause of this outage remains unknown. Most probably the machine might have tripped while they were undertaking this test. On 7th June, the reactor achieved its much-awaited milestone of 1000 MW(e)(e) and stayed stable around this mark for three days. Again at 18.27 hrs on 10 June, the reactor tripped due to control system, heralding the fifth interruption of the C-3 commissioning tests. Part-2 of this study based on an analysis of SRLDC's generation and outage data since the generator's grid connection reveals

long duration outages lasting for 85 days, most of them due to the malfunctioning of the turbine-generator and the feed-water system. Are these long duration outages normal and expected during the commissioning? China's Hongyanhe-1 reactor (1061 MW(e) PWR) started commercial generation 108 days after the grid connection.¹¹

We had earlier reported that the main equipment like reactor pressure vessel, polar crane etc of KKNPP are obsolete and counterfeit. There were other fatal mistakes like breaking open the containment wall for incorporating the cables which were missed earlier¹² On the quality of equipment installed in KKNPP reactors Buddhi Kota Subbarao wrote: “Men may lie, machines do not. The substandard components allegedly supplied by a Russian Company for the Koodankulam Nuclear Power Plant in Southern India caused the Nuclear Plant to become a Speaking Tree. What it speaks now contains salient lessons for India and Russia for the good of people of both the countries”.¹³

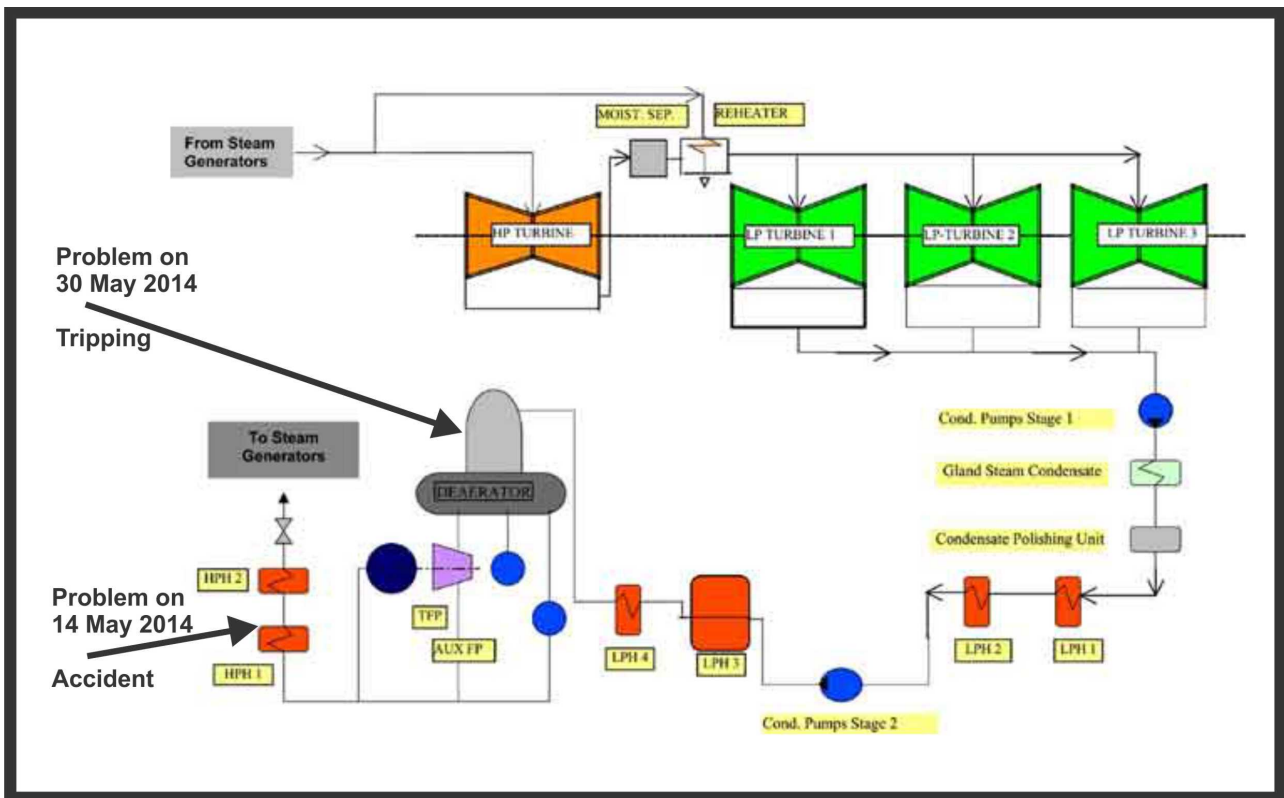

Figure-1 : Flow chart Feed-water system of KKNPP

AERB's accident analysis released by the PIB of the Government of India is not convincing as it does not tally with the available evidence. Incidentally, the 14 May accident was a culmination of the events that began on 9th May 2014, a day after the Supreme Court of India refused to order an independent investigation of the affair-la-KKNPP, on the strength of the assurances given by the AERB. The 14 May incidents, and events before and after this date, are all preserved for posterity in

the documentation – text, audio and video – as part of the initial start-up exercise. We cannot stress the seriousness of situation in KKNPP that warrants an independent inquiry by experts with no vested interests in, or connections to the authorities cited above.

Acknowledgement:

We gratefully acknowledge the advisory support from Dr Buddhi Kota Subbarao, Dr MV Ramana, Dr Anisur Rahman, and AP Suresan. We fondly remember the support and encouragements from colleagues- Leslie Augustine, K Satish, KEK Sateesh and K Sahadevan.

The research for this paper was done at the Society of Science, Environment and Ethics (So-SEE).

Conflict of interests: None declared

- 1 <http://indianexpress.com/article/india/india-others/supreme-court-dismisses-plea-to-stall-commissioning-of-kudankulam-nuclear-plant/> (Accessed on 6 June 2014)
- 2 <http://www.thehindu.com/news/national/tamil-nadu/six-employees-injured-at-kudankulam-nuclear-plant/article6008550.ece>
(Accessed on 6 June 2014)
- 3 <http://www.thehindu.com/todays-paper/tp-national/six-suffer-serious-burns-in-kudankulam-plant-mishap/article6010515.ece?css=print> (Accessed on 6 June 2014)
- 4 <http://pib.nic.in/newsite/erelease.aspx?relid=105109> (Accessed on 6 June 2014)
- 5 <http://www.srldc.org/var/ftp/reports/unit/2014/May14/12-05-2014-unit.pdf>
- 6 <http://www.outlookindia.com/news/article/NPCIL-Dismissses-Reports-of-Blast-at-Kudankulam-Plant/840756> (Accessed on 6 June 2014)
- 7 Anisur Rahman, on E-mail dated 09 June 2014
- 8 <http://www.srldc.org/var/ftp/reports/unit/2013/Oct13/29-10-2013-unit.pdf>
- 9 <http://www.srldc.org/var/ftp/reports/unit/2014/May14/12-05-2014-unit.pdf>
- 10 <http://www.srldc.org/var/ftp/reports/unit/2014/May14/19-05-2014-unit.pdf>
- 11 <http://www.iaea.org/PRIS/CountryStatistics/ReactorDetails.aspx?current=904>
- 12 VT Padmanabhan, R Ramesh, V Pugazhendi, K Sahadevan, Raminder Kaur, Christopher Busby, M Sabir and Joseph Makkolil Counterfeit/obsolete Equipment and Nuclear Safety issues of VVER-1000 Reactors at Kudankulam, India .
<https://independent.academia.edu/PadmanabhanVt/Papers> (Accessed on 6 June 2014)
- 13 Buddhi Kota Subbarao.Ph.D. 4 March, 2013· Koodankulam Nuclear Plant Has Salient Lessons For India And Russia
<http://www.countercurrents.org/subbarao240413.htm> (Accessed on 6 June 2014)