

New Insight of Single Photon and Electron Interference

Masahito Morimoto^{1,*}

¹*Fitel Photonics Laboratory of Furukawa Electric Co.,
Ltd., 6, Yawata-Kaigandori, Ichihara, Chiba Japan*

Here we analyze the single photon and electron interference experiments. According to Maxwell equations, the interferences using a Mach-Zehnder or 2-slit Interferometers can be described by a localized optical or electron wave in one path and non-observable vector and scalar potentials in the other path. We show we can calculate the single photon and electron interferences without quantum-superposition states assuming that the states are expressed as the localized optical or electron beam and the non-observable potentials. From the analysis results, the non-observable potentials can be identified as an indefinite metric vector with zero probability amplitude. The results insist there is no concept of quantum-superposition states, which leads to an improved understanding of the uncertainty principle and resolution of paradox of reduction of the wave packet, elimination of zero-point energy on average and derivation of spontaneous symmetry breaking without complexity. The results insist Quantum theory is a kind of statistical physics.

I. INTRODUCTION

Basic concept of the quantum theory is the quantum-superposition states. Arbitrary states of a system can be described by pure states which are superposition of eigenstates of the system. Calculation results by the concept agree well with experiment. Without the concept, single photon or electron interference could not be explained. In addition to the interference, entangle states also could not be explained.

However the concept leads to the paradox of the reduction of the wave packet typified by "Schrödinger's cat" and "Einstein, Podolsky and Rosen (EPR)". [1, 2]

Although there were a lot of arguments about the paradoxes, recent paper related to the quantum interferences convince us of the validity of the concept. For example, quantum mechanical superpositions by some experiments have been reviewed. [3] The atom interference by using Bose-Einstein condensates (BECs) has been reported experimentally and theoretically. [4, 5] The coherence length of an electron or electron-electron interference by using the Aharonov-Bohm oscillations in an electronic MZI has been discussed theoretically. [6, 7] A plasmonic modulator utilizing an interference of coherent electron waves through the Aharonov-Bohm effect has been studied by the author. [8] The entangle states have been widely discussed experimentally and theoretically. [9–14] The photon interference by using nested MZIs and vibrate mirrors has been measured and analyzed. [15, 16] The double-slit electron diffraction has been experimentally demonstrated. [17] According to our analysis, BECs corresponds to mixed states with coherence rather than pure states. The paper related to the entangle state, interferences by nested MZIs and Aharonov-Bohm effect [6–8, 13–16] can not solve the paradoxes. However, BECs, condensate and bosonization systems correspond to mixed states with or without coherence

rather than pure states, and no paper can solve the paradoxes.

In this paper, we offer a new insight of the single photon and electron interference that can solve the paradoxes. According to the new insight, there is no concept of quantum-superposition and pure states whose probabilities are fundamental sense in nature. Only the concept of mixed states whose probabilities are statistical sense is valid in nature. The new insight gives us novel and important results, i.e., improved understanding of the uncertainty principle non-related to measurements, elimination of zero-point energy on average without artificial subtraction, derivation of spontaneous symmetry breaking without complexity and knowledge that Quantum theory is a kind of statistical physics.

In addition, new insight can conclude that the concept of entangle state is also not valid in nature though there have been reported the validity of the concept of entangle states. [9–14] We will discuss the entangle state by using the new insight in other letter. [18]

In section II, we show easy example of Gaussian photon beam to explain that single photon can be described by substantial (localized) photon and non-observable potentials. In addition, more general description by using gauge invariance is offered. In section IV, we also show easy explanation that we should recognize the existence of the potentials in two-slit electron interference experiment. In section III and V, we show the calculation of the interferences by using states represent the substantial photon or electron and the non-observable potentials, which does not require quantum-superposition states. In section VI, we discuss the paradoxes related to quantum-superposition states, zero-point energy, spontaneous symmetry breaking and general treatment of single particle interferences. In section VII, we summarize the findings of this work.

Aharonov and Bohm had pointed out the non-observable potentials can effect the electron wave interferences and the effect had been experimentally identified by Tonomura et. al. [19–21]

The findings has pointed out the non-observable po-

* morimoto@ch.furukawa.co.jp

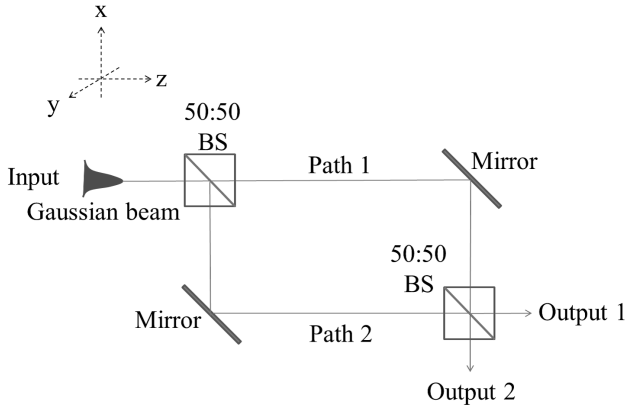

FIG. 1. Schematic view of MZI. BS:Beam Splitter.

tentials, which can be identified as gauge fields, generate not only Aharonov-Bohm effect but also single photon, electron or an arbitrary particle field interferences and fluctuation of the universe as will be described later in this paper.

The discussions in this paper are very simple to the same level as an introductory of quantum theory, because the quantum theory has a misunderstanding in such a fundamental concept and nature of nature will be simple.

II. CLASSICAL ELECTROMAGNETIC FIELD OF MZI - POTENTIALS AND PHOTON

Figure 1 shows schematic view of the Mach-Zehnder Interferometer (MZI) and coordinate system.

First we examine the input beam. Assume that an x-polarized optical beam propagates in z-direction with angular frequency ω and propagation constant β , the electric field \mathbf{E} of the optical beam is well localized in the free space, e.g., the cross section profile of the electric field is expressed as Gaussian distribution.

Then, the electric field of the optical beam in the input can be expressed as follows.

$$\mathbf{E} = \mathbf{e}_x \cdot C_E \cdot \exp\left(-\frac{x^2 + y^2}{w_0^2}\right) \cdot \cos(\omega t - \beta z) \quad (1)$$

Where, \mathbf{e}_x is unit vector parallel to the x-axis. C_E is an arbitrary constant of which squared is proportional to the field intensity. w_0 is the radius of the optical beam. \mathbf{E} and \mathbf{B} are expressed by vector and scalar potentials as follows.

$$\begin{aligned} \mathbf{E} &= -\frac{\partial}{\partial t} \mathbf{A} - \nabla \phi \\ \mathbf{B} &= \nabla \times \mathbf{A} \end{aligned} \quad (2)$$

From (1) and (2), \mathbf{A} is expressed by introducing a vector

function \mathbf{C} as follows.

$$\begin{aligned} \mathbf{A} &= -\frac{1}{\omega} \mathbf{e}_x \cdot C_E \cdot \exp\left(-\frac{x^2 + y^2}{w_0^2}\right) \cdot \sin(\omega t - \beta z) + \mathbf{C} \\ \frac{\partial}{\partial t} \mathbf{C} &= -\nabla \phi \end{aligned} \quad (3)$$

By taking \mathbf{C} as an irrotational vector function $\nabla \times \mathbf{C} = 0$ in order for \mathbf{B} to localize in the space, for example, \mathbf{C} and ϕ can be expressed by introducing an arbitrary scalar function λ as $\mathbf{C} = \nabla \lambda$ and $\nabla \left(\frac{\partial}{\partial t} \lambda + \phi\right) = 0$ respectively.

Then \mathbf{B} is expressed as follows

$$\begin{aligned} \mathbf{B} &= \nabla \times \mathbf{A} \\ &= \frac{\beta}{\omega} \mathbf{e}_y \cdot C_E \cdot \exp\left(-\frac{x^2 + y^2}{w_0^2}\right) \cdot \cos(\omega t - \beta z) \\ &\quad - \frac{2y}{\omega \cdot w_0^2} \mathbf{e}_z \cdot C_E \cdot \exp\left(-\frac{x^2 + y^2}{w_0^2}\right) \cdot \sin(\omega t - \beta z) \end{aligned} \quad (4)$$

Therefore, \mathbf{E} and \mathbf{B} are localized in the free space in the input. In contrast, the vector and scalar potentials, which can not be observed alone, are not necessarily localized.

Note that, the Gaussian beam radius will be spatially expanded due to the free space propagation. However, the radius of the propagated beam $w(z)$ will be approximately 10.5mm when the beam with the initial radius $w_0 = 10\text{mm}$ propagates $z = 100\text{m}$ in free space.

This value can be calculated by $w(z) = w_0 \sqrt{1 + \left(\frac{\lambda z}{\pi w_0^2}\right)^2}$ when the wavelength $\lambda = 1\mu\text{m}$ is applied. Then the spatial expansion of the beam will be negligible small when the paths of the MZI are less than several tens meters.

The above localized form (1) is one example, other forms can be expressed as follows.

Let examine the following Maxwell equations.

$$\begin{aligned} \left(\Delta - \frac{1}{c^2} \frac{\partial^2}{\partial t^2}\right) \mathbf{A} - \nabla \left(\nabla \cdot \mathbf{A} + \frac{1}{c^2} \frac{\partial \phi}{\partial t}\right) &= -\mu_0 \mathbf{i} \\ \left(\Delta - \frac{1}{c^2} \frac{\partial^2}{\partial t^2}\right) \phi + \frac{\partial}{\partial t} \left(\nabla \cdot \mathbf{A} + \frac{1}{c^2} \frac{\partial \phi}{\partial t}\right) &= -\frac{\rho}{\varepsilon_0} \end{aligned} \quad (5)$$

where μ_0 is the permeability and ρ is the electric charge density.

Here, we divide the potentials \mathbf{A} , ϕ into localized \mathbf{A}_1 , ϕ_1 and non-observable \mathbf{A}_{no} , ϕ_{no} . Then the equations (5) can be divided into following equations

$$\begin{aligned} \left(\Delta - \frac{1}{c^2} \frac{\partial^2}{\partial t^2}\right) \mathbf{A}_1 - \nabla \left(\nabla \cdot \mathbf{A}_1 + \frac{1}{c^2} \frac{\partial \phi_1}{\partial t}\right) &= -\mu_0 \mathbf{i} \\ \left(\Delta - \frac{1}{c^2} \frac{\partial^2}{\partial t^2}\right) \phi_1 + \frac{\partial}{\partial t} \left(\nabla \cdot \mathbf{A}_1 + \frac{1}{c^2} \frac{\partial \phi_1}{\partial t}\right) &= -\frac{\rho}{\varepsilon_0} \end{aligned} \quad (6)$$

and

$$\begin{aligned} \left(\Delta - \frac{1}{c^2} \frac{\partial^2}{\partial t^2}\right) \mathbf{A}_{\text{no}} - \nabla \left(\nabla \cdot \mathbf{A}_{\text{no}} + \frac{1}{c^2} \frac{\partial \phi_{\text{no}}}{\partial t}\right) &= 0 \\ \left(\Delta - \frac{1}{c^2} \frac{\partial^2}{\partial t^2}\right) \phi_{\text{no}} + \frac{\partial}{\partial t} \left(\nabla \cdot \mathbf{A}_{\text{no}} + \frac{1}{c^2} \frac{\partial \phi_{\text{no}}}{\partial t}\right) &= 0 \end{aligned} \quad (7)$$

When $\mathbf{i} = 0$ and $\rho = 0$, the equations (6) can express the localized electromagnetic fields in free space as described in the above.

In contrast, the equations (7) are independent of (6). Note that even if we study a wave packet like optical beam instead of continuous one in z-axis as (1), non-observable potentials (7) are independent of the beam configuration. In addition, even if there are no optical beam, the non-observable potentials (7) exist. Therefore the non-observable potentials can eternally populate the whole of space as waves defined by Maxwell equations, which propagate at the speed of light. If the Lorentz condition is applied to (7), the non-observable potentials can exist in whole space as harmonic oscillators.

(7) expresses the gauge invariance of the localized electro magnetic field or electron flows and the non-observable potentials are well-known gauge field introduced by gauge transformation of the second kind.

III. INTERFERENCE OF SINGLE PHOTON

If Maxwell equations are deemed to be classical wave equations whose electro-magnetic fields obey the superposition principle, then we can express the electric field of the interference by the superposition fields (superposition of divided fields of the input) $\mathbf{E}_{\text{out}} = \frac{1}{2}\mathbf{E}_1 + \frac{1}{2}\mathbf{E}_2$.

However, we can express the electric field of the interference without superposition by using the non-observable potentials as follows.

$$\begin{aligned}\mathbf{E}_{\text{out}} &= -\frac{\partial}{\partial t}\mathbf{A}_1 - \nabla\phi_1 - \frac{\partial}{\partial t}\mathbf{A}_{\text{nl}} - \nabla\phi_{\text{nl}} \\ &= \mathbf{E}_1 - \frac{\partial}{\partial t}\mathbf{A}_{\text{nl}} - \nabla\phi_{\text{nl}}\end{aligned}\quad (8)$$

If the non-observable potentials configure the following electric field, the interference by one side MZI path can be produced in cooperation with a photon field passes through path 1.

$$-\frac{\partial}{\partial t}\mathbf{A}_{\text{nl}} - \nabla\phi_{\text{nl}} = \frac{1}{2}\mathbf{E}_2 - \frac{1}{2}\mathbf{E}_1\quad (9)$$

where subscripts 1 and 2 stand for the MZI path 1 and 2 respectively.

The above discussion is based on classical description. However, applying the superposition principle to particle image, e.g., inseparable single photon, leads to quantum paradoxes. Then we translate the above classical description using the non-observable potentials to quantum description without paradoxes.

In a quantum mechanical description, the photon interference is calculated by introducing the electric field operator $\hat{E} = \frac{1}{\sqrt{2}}\hat{a}_1 \exp(i\theta) + \frac{1}{\sqrt{2}}\hat{a}_2$ and the number state $|n\rangle$ as follows. [22] Where $\hat{a}_{1\text{or}2}$ is the electric field operator in path 1 or 2 respectively, θ is the phase difference.

$$\langle \hat{I} \rangle \propto \frac{1}{2}\langle n|\hat{a}_1^\dagger\hat{a}_1|n\rangle + \frac{1}{2}\langle n|\hat{a}_2^\dagger\hat{a}_2|n\rangle + \cos\theta\langle n|\hat{a}_1^\dagger\hat{a}_2|n\rangle\quad (10)$$

Where $\langle \hat{I} \rangle$ is expectation value of the field intensity which is proportional to photon number. $\hat{a}_{1\text{or}2}$ and $\hat{a}_{1\text{or}2}^\dagger$ are defined as $\hat{a} = \frac{\hat{a}_1 + \hat{a}_2}{\sqrt{2}}$ and $\hat{a}^\dagger = \frac{\hat{a}_1^\dagger + \hat{a}_2^\dagger}{\sqrt{2}}$ by using the electric field operators \hat{a} and \hat{a}^\dagger at the input with $\langle n|\hat{a}_1^\dagger\hat{a}_1|n\rangle = \langle n|\hat{a}_2^\dagger\hat{a}_2|n\rangle = \langle n|\hat{a}_1^\dagger\hat{a}_2|n\rangle = \frac{1}{2}n$. When photon number is one ($n = 1$), i.e., single photon, the above expectation value is calculated to be $\langle \hat{I} \rangle \propto \frac{1}{4} + \frac{1}{4} + \frac{1}{2}\cos\theta = \frac{1}{2} + \frac{1}{2}\cos\theta$. In this traditional treatment, the electric field operators are obtained from quantization of (5) by using Coulomb gauge under assumption of $\mathbf{i} = 0$ and $\rho = 0$.

However we can make a different description by using the concept of the above non-observable potentials as follows.

Photon number will be proportional to C_E squared in equation (3). In contrast, the non-observable potentials \mathbf{C} and ϕ or (7) are not necessarily proportional to photon number. When there are a large number of photons, it is reasonable to suppose that half of photons pass through path 1 and the rest pass through path 2 by law of large numbers because the probability of "which path does each photon select" should be $\frac{1}{2}$. This concept corresponds to mixed state instead of quantum-superposition state whose probabilities are statistical and fundamental sense respectively.

However when there are only a few photons, which correspond to the localized vector potential expressed as first term of equation (3) is comparable with the non-observable potentials expressed as the rest terms or (7), we should consider greater probability that only the localized vector potential which represent a photon selects and passes through path 1 and the non-observable potentials pass through path 2. This description can also be applied to (6) and (7).

According to this description, the operator $\hat{E} = \hat{a}_1 \exp(i\theta) + \hat{a}_2$ with $\langle 1|\hat{a}_1^\dagger\hat{a}_1|1\rangle = 1$ and $\langle 1|\hat{a}_2^\dagger\hat{a}_2|1\rangle \neq 1$ instead of $\hat{E} = \frac{1}{\sqrt{2}}\hat{a}_1 \exp(i\theta) + \frac{1}{\sqrt{2}}\hat{a}_2$ should be introduced because the photon passes through only path 1. Note that \hat{a}_1 is the electric field operator in path 1 obtained from the traditional quantization as mentioned above using (6) instead of (5). In contrast, \hat{a}_2 is a purely-formal operator in path 2 obtained from the traditional quantization using (7) instead of (5), which is not the electric field operator but provides some quantity related to the non-observable potentials in path 2.

Therefore the expectation value of output 1 ($\frac{\pi}{2}$ phase difference will correspond to output 2) can be expressed as follows.

$$\begin{aligned}\langle \hat{I} \rangle &\propto \langle 1|\hat{a}_1^\dagger\hat{a}_1|1\rangle + \langle 1|\hat{a}_2^\dagger\hat{a}_2|1\rangle \\ &\quad + e^{i\theta}\langle 1|\hat{a}_1^\dagger\hat{a}_2|1\rangle + e^{-i\theta}\langle 1|\hat{a}_2^\dagger\hat{a}_1|1\rangle \\ &= 1 + \langle 1|\hat{a}_2^\dagger\hat{a}_2|1\rangle \\ &\quad + e^{i\theta}\langle 1|\hat{a}_1^\dagger\hat{a}_2|1\rangle + e^{-i\theta}\langle 1|\hat{a}_2^\dagger\hat{a}_1|1\rangle\end{aligned}\quad (11)$$

If $\langle 1|\hat{a}_2^\dagger\hat{a}_2|1\rangle = -\frac{1}{2}$ and $\langle 1|\hat{a}_1^\dagger\hat{a}_2|1\rangle = \langle 1|\hat{a}_2^\dagger\hat{a}_1|1\rangle^* = \pm\frac{1}{4}e^{i\phi}$, the same interference $\langle \hat{I} \rangle \propto \frac{1}{2} \pm \frac{1}{2}\cos(\theta + \phi)$ can be observed. Where * means complex conjugate.

The above calculation is based on Heisenberg picture. We can calculate the same interference based on Schrödinger picture. In Schrödinger picture, the interference can be calculated by using the output 1 (or 2: $\frac{\pi}{2}$ phase difference) state $|1\rangle + |\zeta\rangle$ and the electric field operator $\hat{E} = \hat{a}$ at the output 1 (or 2). Because the operator is fixed in Schrödinger picture, the operator is obtained from the traditional quantization using (5). Where $|1\rangle$ and $|\zeta\rangle$ represent the states of a photon passes through path 1 and non-observable potentials passes through path 2 respectively. Because nothing is observed in path 2, we should recognize $\langle\zeta|\zeta\rangle = 0$.

In this picture, the expectation value can be expressed as follows.

$$\begin{aligned} \langle\hat{I}\rangle &\propto (e^{i\theta}\langle 1| + \langle\zeta|) \hat{a}^\dagger \hat{a} (e^{-i\theta}|1\rangle + |\zeta\rangle) \\ &= 1 + \langle\zeta|\hat{a}^\dagger \hat{a}|\zeta\rangle + e^{i\theta}\langle 1|\zeta\rangle + e^{-i\theta}\langle\zeta|1\rangle \end{aligned} \quad (12)$$

Where $\hat{a}^\dagger \hat{a}|1\rangle = |1\rangle$ and $\langle 1|\hat{a}^\dagger \hat{a} = \langle 1|$ are used.

If $\langle\zeta|\hat{a}^\dagger \hat{a}|\zeta\rangle = -\frac{1}{2}$ and $\langle 1|\zeta\rangle = \langle\zeta|1\rangle^* = \pm\frac{1}{4}e^{i\phi}$, the same interference $\langle\hat{I}\rangle \propto \frac{1}{2} \pm \frac{1}{2} \cos(\theta + \phi)$ can be observed. From this expression, we can recognize that $|\zeta\rangle$ has the phase difference for the interference without substantial photons.

Note that ϕ is determined by the phase difference of the MZI paths. When there is no phase difference between the MZI paths, ϕ is determined from the normalization of probability, i.e., $(\langle 1| + \langle\zeta|)(|1\rangle + |\zeta\rangle) = \langle 1|1\rangle + \langle 1|\zeta\rangle + \langle\zeta|1\rangle + \langle\zeta|\zeta\rangle = 1 + \langle 1|\zeta\rangle + \langle\zeta|1\rangle + \langle\zeta|\zeta\rangle = 1$, and $\langle\zeta|\zeta\rangle = 0$ then $\langle 1|\zeta\rangle = -\langle\zeta|1\rangle$. Therefore $\phi = \frac{\pi}{2} + N\pi$. Where N is integer.

In the above mathematical formula for the interference by Schrödinger picture, there is no mathematical solution in usual Hilbert space. Therefore the non-observable potentials, which can not be observed alone, must be regarded as a vector in indefinite metric Hilbert space. The same kind of unobservable vector has been introduced as "ghost" in quantum field theory. [23–26] We also call $|\zeta\rangle$ "ghost" in this report though this "ghost" has a different definition. The traditional "ghost" was introduced mathematically as an auxiliary field for consistent with relativistic covariance of the theory and had no effect on physical phenomena. However, the above "ghost" is a physical field which causes the interferences or is essential for the interferences instead of the mathematical auxiliary field.

From the equation (11) and (12), the non-observable potentials pass through path 2 produce the single photon interference as if the photon passes through the both paths in cooperation with a photon field passes through path 1.

The photon number should be proportional to C_E squared as can be seen in equation (3). However non-observable potentials \mathbf{C} and ϕ or (7), which express "ghost", are not proportional to it as mentioned above. Therefore, the interference effect will be drop off when there are a large number of photons. This will be the reason why quantum effects are hardly observed in macroscopic scale.

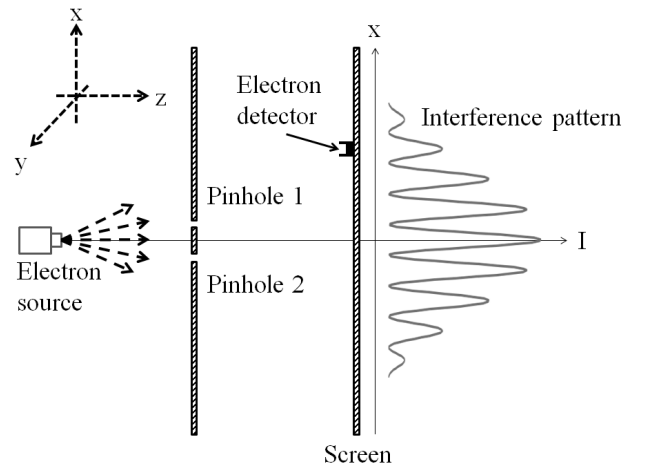

FIG. 2. Schematic view of a typical setup for the 2-slits (2-pinholes) single electron interference experiment.

Note that the superposition principle may be used as a nice mathematical tool to simplify analyses in mixed states. However when we use the superposition principle in single photon case and fail to understand the mechanism of the single photon interference as described above, we may plunge into deniable engineering applications based on reduction of wave packet.

IV. POTENTIALS AND ELECTRON

In this section, we first consider two pinholes electron wave interference in classical manner. Figure 2 shows schematic view of a typical setup for the 2-slits (2-pinholes) single electron interference experiment. [17, 27]

The propagating electron can be identified as an electron beam whose space current density is $j = Nqv$, where N is the number of electron per unit volume, q is the electron charge and v is the electron velocity. When the radius of the electron beam is w_0 , the current I can be expressed as $I = \pi w_0^2 j$. According to Biot-Savart Law, the propagation generates magnetic fields and potentials around the propagation path.

Assume that the electron propagates parallel to z-axis at a constant velocity. Then, the vector potentials around the propagation path are expressed as [27, 28]

$$\begin{aligned} A_x &= A_y = 0 \\ A_z &= \frac{I}{2\pi\epsilon_0 c^2} \ln \frac{1}{r} \end{aligned} \quad (13)$$

where $r = \sqrt{x^2 + y^2}$, ϵ_0 is the permittivity and c is the speed of light.

Therefore the vector potential clearly passes through not only the pinhole the electron passes through but also the opposite pinhole.

Even if we apart from this easy consideration, the electron motion definitely generates potentials. Therefore,

when we consider the electron motion, we must take the potentials.

In next section, we consider the two pinholes interference in quantum mechanical manner with consideration for the potentials.

V. INTERFERENCE OF SINGLE ELECTRON

In a quantum mechanical description, the 2-slits (pinholes) single electron interference is typically explained by the probability (density) of finding the electron on the screen. [27]

$$P_{12} = |\phi_1 + \phi_2|^2 \quad (14)$$

Where $\phi_1 = \langle x|1\rangle\langle 1|s\rangle$ and $\phi_2 = \langle x|2\rangle\langle 2|s\rangle$, which are composed of probability amplitudes

$\langle 1_{\text{or}}2|s\rangle$: "electron arrives at pinhole 1 or 2|electron leaves s (electron source)" and

$\langle x|1_{\text{or}}2\rangle$: "electron arrives at screen x |electron leaves pinhole 1 or 2".

When either pinhole 1 or 2 is closed, the each and total probabilities are calculated to be $P_1 = |\phi_1|^2$, $P_2 = |\phi_2|^2$ and $P = P_1 + P_2 \neq P_{12}$. Therefore we must admit the electron passes through both pinholes at the same time despite an electron can not be split off, which forces us to introduce a concept of quantum-superposition states

However we can examine the states of the localized electron propagation and non-observable potentials instead of the quantum-superposition state as mentioned above.

In such a case, the electron wave functions should be expressed as follows.

$$\begin{aligned} \psi'_1 &= \psi_1 \cdot \exp \left[i \frac{q}{\hbar} \int_{s \rightarrow \text{Pinhole1}}^{\text{screen}} (\phi_{\text{nl}} dt - \mathbf{A}_{\text{nl}} \cdot d\mathbf{x}) \right] \\ \psi'_2 &= \psi_2 \cdot \exp \left[i \frac{q}{\hbar} \int_{s \rightarrow \text{Pinhole2}}^{\text{screen}} (\phi_{\text{nl}} dt - \mathbf{A}_{\text{nl}} \cdot d\mathbf{x}) \right] \end{aligned} \quad (15)$$

where, ψ'_1 and ψ'_2 are the electron wave functions on the screen passing through pinhole 1 and 2 with the non-observable potentials respectively. ψ_1 and ψ_2 are the electron wave functions heading to pinhole 1 and 2 at the electron source without the effects of the non-observable potentials. ϕ_{no} and \mathbf{A}_{no} include not only the non-observable potentials expressed as (7) but also the non-observable part of the potentials generated by localized potentials such as (3) and (13).

Then the probability of finding the electron on the screen by using these wave functions can be described as follows,

$$\begin{aligned} P_{12} &\propto |\psi'|^2 = |\psi'_1 + \psi'_2|^2 \\ &= |\psi_1|^2 + |\psi_2|^2 \\ &\quad - 2\text{Re} \left(\exp \left[i \frac{q}{\hbar} \oint_{s \rightarrow 1 \rightarrow \text{screen} \rightarrow 2 \rightarrow s} (\phi_{\text{nl}} dt - \mathbf{A}_{\text{nl}} \cdot d\mathbf{x}) \right] \psi_1^* \psi_2 \right) \end{aligned} \quad (16)$$

where 1 and 2 of the integration path denote pinhole 1 and 2 respectively. This description is identical to Aharonov-Bohm effect. [19]

In case of single electron interference, we can find the electron at pinhole 1 without fail but not at pinhole 2, i.e., $|\psi_1|^2 = 1$ and $|\psi_2|^2 = 0$. Although the exact expression should be $\int |\psi_{1\text{or}2}|^2 d\mathbf{V} = 1$ or 0 instead of the probability densities, we continue analysis with $|\psi_1|^2 = 1$ and $|\psi_2|^2 = 0$ for simplification.

When we introduce a phase difference θ between ψ_1 and ψ_2 , P_{12} expresses the interference as follows,

$$P_{12} \propto 1 - 2\text{Re}(\exp i[\gamma + \theta] \psi_1^* \psi_2) \quad (17)$$

where $\gamma = \frac{q}{\hbar} \oint_{s \rightarrow 1 \rightarrow \text{screen} \rightarrow 2 \rightarrow s} (\phi_{\text{nl}} dt - \mathbf{A}_{\text{nl}} \cdot d\mathbf{x})$.

Note that when θ is fixed, the interference can be observed on the screen as a function of γ , i.e., position on the screen. When γ is fixed, the interference can be observed on a fixed position of the screen as a function of θ .

However, the wave function ψ_2 as a probability density must satisfy incoherent expressions, i.e., $\psi_1^* \psi_2 \neq 0$ and $|\psi_2|^2 = 0$.

Then, here we introduce the following states in order to clarify the exact probability representation.

"an electron passes through pinhole 1 with the non-observable potentials" as $e^{i\gamma_1} |\psi_1\rangle$ with $P_1 = \langle \psi_1 | \psi_1 \rangle = \int |\psi_1|^2 d\mathbf{V} = 1$

and

"no electron passes through pinhole 2 with the non-observable potentials" as $e^{i\gamma_2} |\psi_2\rangle$ with $P_2 = \langle \psi_2 | \psi_2 \rangle = \int |\psi_2|^2 d\mathbf{V} = 0$.

In these states, γ_1 , γ_2 and $\gamma = \gamma_1 - \gamma_2$ correspond to the phase terms of (15) and (16).

After the example of single photon interference as described above, [22] we introduce the charge operator $\mathbf{Q} \equiv \int d^3x j_0(x)$ defined by a conserved current $j_\mu = (q, \mathbf{i})$, i.e., $\partial^\mu j_\mu = \frac{\partial q}{\partial t} + \nabla \cdot \mathbf{i} = 0$. The charge operator satisfies $\mathbf{Q} |\psi_1\rangle = q |\psi_1\rangle$, which means the electron state incoming from pinhole 1 is the eigenstate of \mathbf{Q} . [29, 30]

The interference can be calculated using the charge operator as follows.

$$\begin{aligned} \langle I \rangle &= \\ & \left(e^{i(\theta-\gamma_1)} \langle \psi_1 | + e^{-i\gamma_2} \langle \psi_2 | \right) \mathbf{Q} \left(e^{-i(\theta-\gamma_1)} |\psi_1\rangle + e^{i\gamma_2} |\psi_2\rangle \right) \\ &= q + \langle \psi_2 | \mathbf{Q} | \psi_2 \rangle \\ & \quad + q e^{i(\theta-\gamma)} \langle \psi_1 | \psi_2 \rangle + q e^{-i(\theta-\gamma)} \langle \psi_2 | \psi_1 \rangle \end{aligned} \quad (18)$$

where $\langle I \rangle$ is the expectation value of charge intensity. If $\langle \psi_2 | \mathbf{Q} | \psi_2 \rangle = -\frac{1}{2}q$ and $\langle \psi_1 | \psi_2 \rangle = \langle \psi_2 | \psi_1 \rangle^* = \pm \frac{1}{4} e^{i\delta}$, then the single electron interference $\langle I \rangle = q \left\{ \frac{1}{2} + \frac{1}{2} \cos(\theta - \gamma + \delta) \right\}$ can be obtained.

The above discussion suggests that the non-observable potentials produce phase shift of the electron wave functions or electron states and will correspond to gauge fields introduced by gauge transformation of the second kind

as can be seen from (15). Hence, we can recognize the state "no electron passes through pinhole 2 with the non-observable potentials" has the phase difference for the interference without electron charges.

In the above expression for $|\psi_2\rangle$, there is no mathematical solution in usual Hilbert space. Therefore the state of "no electron passes through pinhole 2 with the non-observable potentials" must also be regarded as a vector with zero probability amplitude in indefinite metric Hilbert space and we can express the quantum state of the interference without quantum-superposition state.

Note that the calculation using the superposition state of (16) is valid in case of mixed state whose probability is statistical sense. The superposition states are convenient for application to interference phenomena, however the states do not reflect the right mechanism of nature, which means there are great possibility the quantum application using wave packet reduction of single photon and electron interference will be unavailable.

VI. DISCUSSION

A. uncertainty principle and the reduction of the wave packet

By the existence of the non-observable potentials, Heisenberg's uncertainty principle can be explained independently of measurements. In addition, the paradox of the reduction of the wave packet typified by "Schrödinger's cat" and "Einstein, Podolsky and Rosen (EPR)" [1, 2] can be solved, because the origins of both are quantum-superposition state.

Former results insist the states of path 1 and 2 or pinhole 1 and 2 by Schrödinger picture are defined when the system is prepared expressed as a substantial single photon or electron and the non-observable potentials respectively and each state does not split off such as quantum-superposition state, which means there is no reduction of the wave packet.

"When the system is prepared" corresponds to immediately after the branching point of the optical MZI or the pinholes. Which path or pinhole does the photon or electron select is unpredictable but after the selection, the state is fixed instead of quantum-superposition state. The concept of these states is identical with mixed states rather than pure states formed by quantum-superposition, which suggests there is no concept of quantum-superposition state.

As for Heisenberg's uncertainty principle, we can clearly recognize it as trade-offs derived from Fourier transform non-related to measurement, which correspond to the canonical commutation relation.

B. zero-point energy

If we calculate the equation (12) under vacuum instead of single photon, $\langle\zeta|\hat{a}^\dagger\hat{a}|\zeta\rangle = -\frac{1}{2}$ can eliminate zero-point energy on average as follows.

$$\begin{aligned} & (\langle 0| + \langle \zeta|) \left(\hat{a}^\dagger \hat{a} + \frac{1}{2} \right) (|0\rangle + |\zeta\rangle) \\ &= \frac{1}{2} + \frac{1}{2} (\langle 0|\zeta\rangle + \langle \zeta|0\rangle + \langle \zeta|\zeta\rangle) \\ &+ \langle 0|\hat{a}^\dagger\hat{a}|\zeta\rangle + \langle \zeta|\hat{a}^\dagger\hat{a}|0\rangle + \langle \zeta|\hat{a}^\dagger\hat{a}|\zeta\rangle \\ &= \frac{1}{2} + \langle \zeta|\hat{a}^\dagger\hat{a}|\zeta\rangle + \frac{1}{2} (\langle 0|\zeta\rangle + \langle \zeta|0\rangle) \\ &= \frac{1}{2} - \frac{1}{2} + \frac{1}{2} (\langle 0|\zeta\rangle + \langle \zeta|0\rangle) \\ &= \frac{1}{2} (\langle 0|\zeta\rangle + \langle \zeta|0\rangle) \propto \cos \theta \end{aligned} \quad (19)$$

where $\hat{a}|0\rangle = (\langle 0|\hat{a}^\dagger)^\dagger = 0$, $\langle 0|\zeta\rangle = \langle \zeta|0\rangle^*$ and $\langle \zeta|\zeta\rangle = 0$ are used.

Then averaged energy of all phases θ , which is the phase difference between $|0\rangle$ and $|\zeta\rangle$, becomes 0, i.e., $\overline{\cos \theta} = 0$, where the over-bar means average.

Although the above calculation can eliminate zero-point energy on average, the energy has been measured through Casimir effect. [31–35] The above new insight explains there are no energy on average in vacuum. There is only fluctuation around 0 energy due to the phase difference, The attractive force from this kind of fluctuation is identical with the basic concept of Van der Waals force which will be the origin of Casimir effect. [36]

Therefore the above calculation will not be inconsistent with Casimir effect.

C. spontaneous symmetry breaking

Traditional treatment of the spontaneous symmetry breaking, which explores the possibility of $\mathbf{Q}|0\rangle \neq 0$ or generally " $|0\rangle$ is not an eigenstate of \mathbf{Q} ", needs an intricate discussion using Goldstone boson or Higgs boson. [30, 37] Where $|0\rangle$ is vacuum state.

However, the non-observable potentials eternally populate the whole of space as mentioned above and there are no electron at pinhole 2. Therefore the state of pinhole 2, $e^{i\gamma_2}|\psi_2\rangle$, can be identified as vacuum instead of $|0\rangle$. From the relation $\langle\psi_2|\psi_2\rangle = 0$ as described above, if $e^{i\gamma_2}|\psi_2\rangle$ is an eigenstate of \mathbf{Q} , i.e., $\mathbf{Q}e^{i\gamma_2}|\psi_2\rangle = \alpha e^{i\gamma_2}|\psi_2\rangle$, then $\langle\psi_2|e^{-i\gamma_2}\mathbf{Q}e^{i\gamma_2}|\psi_2\rangle = \alpha\langle\psi_2|\psi_2\rangle = 0 \neq -\frac{1}{2}q$, where α is an eigenvalue. Hence the vacuum $e^{i\gamma_2}|\psi_2\rangle$ is not an eigenstate of \mathbf{Q} , which expresses the spontaneous symmetry breaking.

The above discussion that the new vacuum is filled with potentials (gauge fields) whose state exists under original ground state is identical with the spontaneous symmetry breaking using the analogy of superconductivity when we replace \mathbf{Q} with energy level reported by Y.

Nambu and G. Jona-Lasinio. [38, 39] In addition, the spontaneous symmetry breaking by gauge fields leads to mass acquire of gauge fields (Higgs mechanism). [40]

Therefore the above discussion will not be inconsistent with traditional treatment of spontaneous symmetry breaking and the mass acquire mechanism.

D. general treatment of single particle interferences

From (12) and (18), the single particle interferences can be expressed as following manner.

$$\begin{aligned} \langle I \rangle &= (\langle \phi | + \langle \zeta |) \mathbf{F} (|\phi\rangle + |\zeta\rangle) \\ &= f + \langle \zeta | \mathbf{F} | \zeta \rangle + f \langle \phi | \zeta \rangle + f \langle \zeta | \phi \rangle \end{aligned} \quad (20)$$

Then $\langle \zeta | \mathbf{F} | \zeta \rangle = -\frac{1}{2}f$ and $\langle \phi | \zeta \rangle = \langle \zeta | \phi \rangle^* = \pm \frac{1}{4}e^{i\theta}$ can generate single particle interferences of \mathbf{F} , i.e., $\langle I \rangle = f \left\{ \frac{1}{2} + \frac{1}{2} \cos \theta \right\}$. Where \mathbf{F} is an arbitrary observable operator, $|\phi\rangle$ is a state expressing single particle field, f is the expectation value of \mathbf{F} under state $|\phi\rangle$ and $|\zeta\rangle$ is an indefinite metric vector expressing non-observable potentials. In case of Maxwell equations as described in this paper, $|\zeta\rangle$ is identified as commutative gauge fields (Abelian gauge fields). When we study multicomponent state $|\phi\rangle$, $|\zeta\rangle$ will be identified as non-commutative gauge fields (non-Abelian gauge fields). [41–43] However the above general treatment can be applied in both cases.

When \mathbf{F} is not introduced in (20), the existence probability of the single particle, i.e.,

$$\begin{aligned} (\langle \phi | + \langle \zeta |) (|\phi\rangle + |\zeta\rangle) &= 1 + \langle \phi | \zeta \rangle + \langle \zeta | \phi \rangle \\ &= 1 + \frac{1}{2} \cos \theta \end{aligned} \quad (21)$$

is fluctuated though the average is 1. These kinds of self fluctuation of a particle will be consistent with neutrino oscillation. [44, 45]

VII. SUMMARY

There are some unresolved paradoxes in quantum theory.

If we take advantage of the indefinite metric vectors as described in this report, the paradoxes can be removed. In addition, it can explain the uncertainty principle independently of measurements, eliminate zero-point energy

on average and cause spontaneous symmetry breaking without complexity.

We should consistently introduce indefinite metric vectors because Maxwell equations are wave equations in Minkowski space. When we introduce state vectors in Minkowski space, indefinite metric vectors are absolutely required. The required vector should be recognized not only as an auxiliary field but also as a real physical field which is the root cause of single photon and electron interferences.

The results insist the vacuum space is filled with the non-observable potentials which can eternally exist as waves and correspond to gauge fields introduced by gauge transformation of the second kind.

This idea provides exactly the same calculation and experimental results by using quantum-superposition state because the phase difference between the photon or electron and the non-observable potentials provide the interferences as if the quantum-superposition state exists. In addition, the concept is based on an analogy from the expression of substantial localize electromagnetic fields or an electron and the non-observable potentials instead of curious quantum-superposition state that forces us to imagine a photon or an electron passes through the both paths or pinholes despite a photon or an electron can not be split off.

Furthermore, this idea will not be inconsistent with traditional treatment of Casimir effect, spontaneous symmetry breaking, the mass acquire mechanism and can be applied to non-Abelian gauge fields.

The superposition states are valid in case of mixed states whose probabilities are statistical sense. However, quantum-superposition state is not valid in case of pure state whose probability is fundamental sense, though the superposition principle may be used as a nice mathematical tool to simplify analyses. Therefore, there is no concept of quantum-superposition state in nature, which insists fulfillment of engineering applications based on reduction of wave packet is pessimistic conclusion and Quantum theory is a kind of statistical physics.

M. Arndt and K. Hornberger have reviewed some testing of quantum mechanical superpositions, [3] we hope the results will be tested by those technologies.

ACKNOWLEDGMENT

The author would like to thank K. Sato, Dr. S. Takasaka and Dr. S. Matsushita for their helpful discussions.

-
- [1] J. D. Trimmer, Proceedings of the American Philosophical Society **124**, 323 (1980).
 [2] A. Einstein, B. Podolsky, and N. Rosen, Phys. Rev **47**, 777 (1935).

- [3] M. Arndt and K. Hornberger, Nature Physics. **10**, 271 (2014).
 [4] J. Grond, U. Hohenester, J. Schmiedmayer, and A. Smerzi, Phys. Rev. A **84**, 023619 (2011).

- [5] G. D. McDonald, H. Keal, P. A. Altin, J. E. Debs, S. Bennettts, C. C. N. Kuhn, K. S. Hardman, M. T. Johnsson, J. D. Close, and N. P. Robins, *Phys. Rev. A* **87**, 013632 (2013).
- [6] G. Haack, M. Moskalets, J. Splettstoesser, and M. Büttiker, *Phys. Rev. B* **84**, 081303 (2011).
- [7] S. Ngo Dinh, D. A. Bagrets, and A. D. Mirlin, *Phys. Rev. B* **87**, 195433 (2013).
- [8] M. Morimoto, Selected Topics in Quantum Electronics, *IEEE Journal of* **19**, 14 (2013).
- [9] A. Aspect, P. Grangier, and G. Roger, *Physical review letters* **47**, 460 (1981).
- [10] A. Aspect, P. Grangier, G. Roger, *et al.*, *Physical review letters* **49**, 91 (1982).
- [11] A. Aspect, J. Dalibard, and G. Roger, *Physical review letters* **49**, 1804 (1982).
- [12] S. P. Walborn, M. O. Terra Cunha, S. Pádua, and C. H. Monken, *Phys. Rev. A* **65**, 033818 (2002).
- [13] V. Jacques, E. Wu, F. Grosshans, F. m. c. Treussart, P. Grangier, A. Aspect, and J.-F. m. c. Roch, *Phys. Rev. Lett.* **100**, 220402 (2008).
- [14] S. Longhi, *Phys. Rev. B* **79**, 245108 (2009).
- [15] A. Danan, D. Farfurnik, S. Bar-Ad, and L. Vaidman, *Phys. Rev. Lett.* **111**, 240402 (2013).
- [16] P. L. Saldanha, *Phys. Rev. A* **89**, 033825 (2014).
- [17] R. Bach, D. Pope, S.-H. Liou, and H. Batelaan, *New Journal of Physics* **15**, 033018 (2013).
- [18] M. Morimoto, <http://vixra.org/abs/1405.0006> (2014).
- [19] Y. Aharonov and D. Bohm, *Phys. Rev.* **115**, 485 (1959).
- [20] A. Tonomura, T. Matsuda, J. Endo, T. Arii, and K. Mi-hama, *Phys. Rev. Lett.* **44**, 1430 (1980).
- [21] A. Tonomura, H. Umezaki, T. Matsuda, N. Osakabe, J. Endo, and Y. Sugita, *Phys. Rev. Lett.* **51**, 331 (1983).
- [22] R. Loudon, *The quantum theory of light*, 2nd ed. (Oxford University Press, 1983).
- [23] P. A. M. Dirac, *Proc. Roy. Soc. London A* **180**, 1 (1942).
- [24] W. Pauli and F. Villars, *Rev. Mod. Phys* **21**, 434 (1949).
- [25] S. N. Gupta, *Proc. Phys. Soc. A* **66**, 129 (1953).
- [26] T. D. Lee and G. C. Wick, *Phys. Rev. D* **2**, 1033 (1970).
- [27] R. P. Feynman, R. B. Leighton, and M. L. Sands, *The Feynman Lectures on Physics Vol.II, III* (Addison-Wesley, 1965).
- [28] J. A. Stratton, *Electromagnetic Theory* (McGraw-Hill, 1941).
- [29] E. Karlson, Proceedings of the Royal Society of London. Series A, Mathematical and Physical Sciences **230**, 382 (1955).
- [30] C. Itzykson and J. B. Zuber, *Quantum Field Theory* (McGraw-Hill, 1985).
- [31] R. L. Jaffe, *Phys. Rev. D* **72**, 021301 (2005).
- [32] E. Myers, *Phys. Rev. Lett.* **59**, 165 (1987).
- [33] S. K. Lamoreaux, *Phys. Rev. Lett.* **78**, 5 (1997).
- [34] U. Mohideen and A. Roy, *Phys. Rev. Lett.* **81**, 4549 (1998).
- [35] I. Brevik, V. N. Marachevsky, and K. A. Milton, *Phys. Rev. Lett.* **82**, 3948 (1999).
- [36] W. Arnold, S. Hunklinger, and K. Dransfeld, *Phys. Rev. B* **19**, 6049 (1979).
- [37] J. Goldstone, A. Salam, and S. Weinberg, *Phys. Rev.* **127**, 965 (1962).
- [38] Y. Nambu and G. Jona-Lasinio, *Phys. Rev.* **122**, 345 (1961).
- [39] Y. Nambu and G. Jona-Lasinio, *Phys. Rev.* **124**, 246 (1961).
- [40] P. W. Higgs, *Phys. Rev. Lett.* **13**, 508 (1964).
- [41] C. N. Yang and R. L. Mills, *Phys. Rev.* **96**, 191 (1954).
- [42] T. T. Wu and C. N. Yang, *Phys. Rev. D* **12**, 3845 (1975).
- [43] S. Weinberg, *Phys. Rev. Lett.* **19**, 1264 (1967).
- [44] A. K. Mann and H. Primakoff, *Phys. Rev. D* **15**, 655 (1977).
- [45] G. Feldman, J. Hartnell, and T. Kobayashi, *Adv.High Energy Phys.* **2013**, 475749 (2013), arXiv:1210.1778 [hep-ex].