

Mathematical Proof of Four-Color Theorem

By Liu Ran

1. Introduce

How many different colors are sufficient to color the countries on a map in such a way that no two adjacent countries have the same color? After examining a wide variety of different planar graphs, one discovers the apparent fact that every graph, regardless of size or complexity, can be colored with just four distinct colors.

The famous four color theorem, sometimes known as the four-color map theorem or Guthrie's problem. In mathematical history, there had been numerous attempts to prove the supposition, but these so-called proofs turned out to be flawed. There had been accepted proofs that a map could be colored in using more colors than four, such as six or five, but proving that only four colors were required was not done successfully until 1976 by mathematicians Appel and Haken, although some mathematicians do not accept it since parts of the proof consisted of an analysis of discrete cases by a computer. But, at the present time, the proof remains viable. It is possible that an even simpler, more elegant, proof will someday be discovered, but many mathematicians think that a shorter, more elegant and simple proof is impossible.

2. Four color theorem

(2.1) For any subdivision of the spherical surface into non-overlapping regions, it is always possible to mark each of the regions with one of the numbers 0, 1, 2, 3 in such a way that no two adjacent regions receive the same number.

In fact, if the four-color theorem is true on spherical surface, it is also true on plane surface. Because the map is originally spherical, and plane surface is part of spherical surface.

3. Strategy

4-4 adjacent countries are the biggest adjacent relationship, four-color theorem is true because more than 5 countries, there must be a no adjacent country existing. No adjacent countries can be color by the same one color.

To prove 4-4 adjacent countries are the biggest adjacent relationship, I have used an axiom and a complex proof. It's better to find a simpler proof. Now, my method is to transform a map to a circle map to prove it.

4. Basic axiom

(4.1) Coloring the countries on a map has nothing to do with the country shape.

This is the only one axiom in proof. It's obviously true.

Theorem (4.2)

All color solutions for boundary adjacent countries can apply to point adjacent countries or no adjacent countries.

We define adjacent regions as those that share a common boundary of non-zero length. Regions, which meet at a single point or limited points, are not considered to be "adjacent".

Because point adjacent countries are not considered to be "adjacent", any color solution can apply to point adjacent countries, include the color solution of boundary adjacent countries. The free degree of no adjacent countries is limitless. So any color solution of boundary adjacent countries can apply to point adjacent countries and no adjacent countries.

For example:

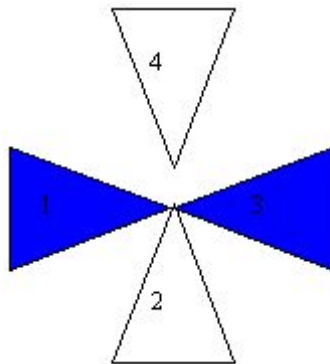

Scenario a: no adjacent and point adjacent

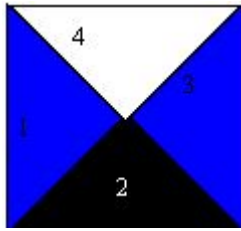

Scenario b: boundary adjacent

All color solutions for Scenario b can apply to Scenario a.

Theorem (4.3)

Any irregular countries map can transform into a circle countries map.

The color solution for circle countries map can also apply to the irregular countries map

Because basic axiom (4.1) \Rightarrow any irregular countries map can transform into circle-shaped, ring-shaped or fan-shaped.

If circle-shaped, ring-shaped or fan-shaped are point adjacent or no adjacent, transform into boundary adjacent, finally, to transform into a circle map, ring-shaped and fan-shaped surround circle. Because of Theorem (4.2), the color solution for map transformed can apply to the color solution for map transform ago.

For example:

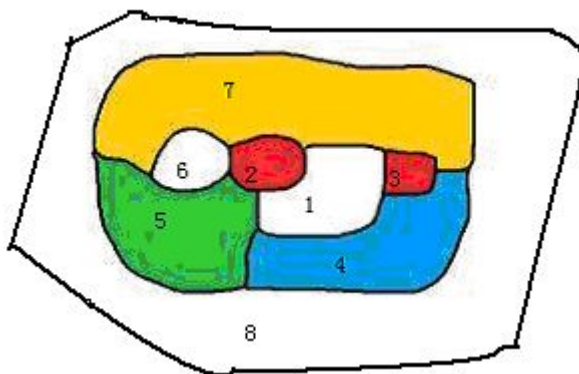

This an irregular map.

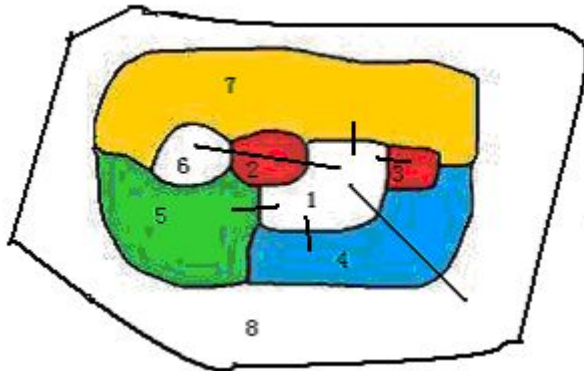

To ensure arbitrary map can be transform into circle map, first select a circle center, second draw a line from center to country, the least country number crossed over is the layer number of ring. From 1 to 6, the least country number is 2, from 1 to 8, the least country number is 2, and so both 6 and 8 are in layer 2 in circle map. Other countries are in layer 1.

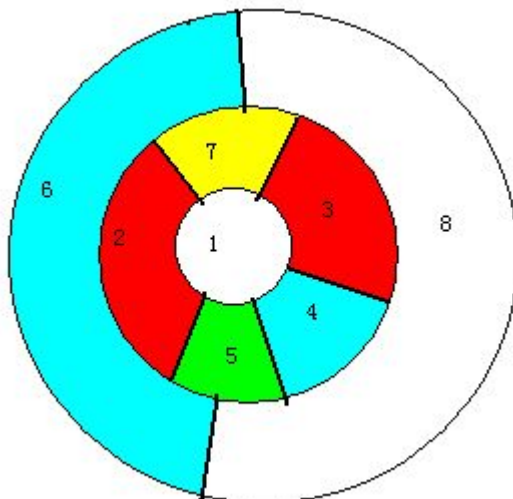

Transform irregular map to circle map, 1 is circle center, 6 and 8 are in layer 2. Other countries are in layer 1. The boundary adjacent relation is never changed, but some point adjacent or no adjacent relations are

changed to boundary adjacent relation to match the circle map transforming.

Country 6 is not adjacent with country 8, but to transform into circle map, country 6 become boundary adjacent with country 8 to match the circle map transforming.

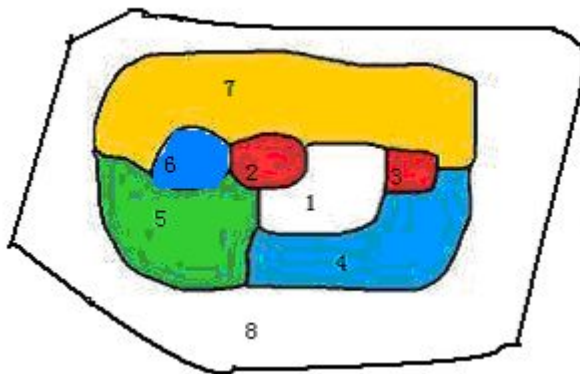

The color solution for circle map transformed can apply to irregular map also. Country 6 has changed color, but there is no same color between boundary adjacent countries. It is a color solution qualified.

5. Terminology

To describe conveniently, I have defined some terms in circle map.

No adjacent regions as those no point met.

For example: 1 is no adjacent with 2 in below circle map.

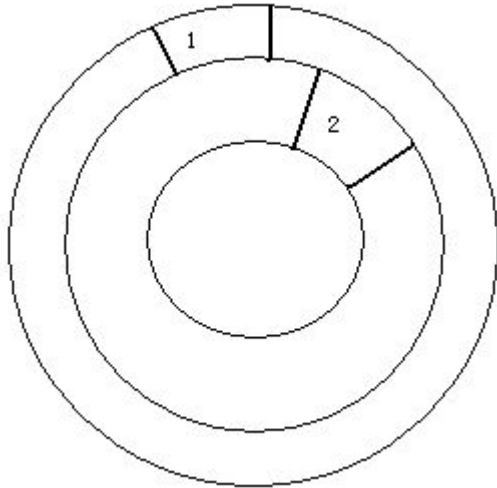

Point adjacent regions as those that meet at a single point or limited points

For example: 1 is point adjacent with 2 in below circle map.

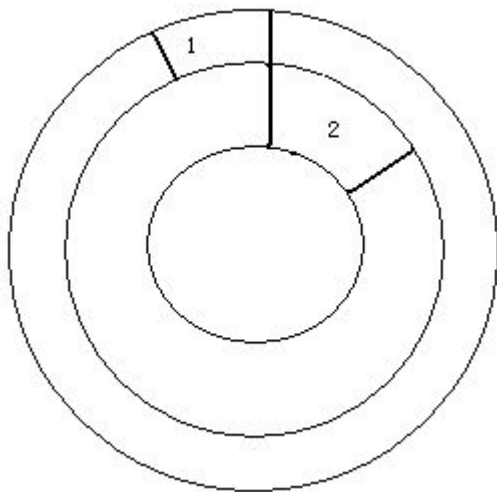

Boundary adjacent regions as those that share a common boundary of non-zero length.

For example: 1, 2, 3 are all boundary adjacent with other 2 countries in below circle map.

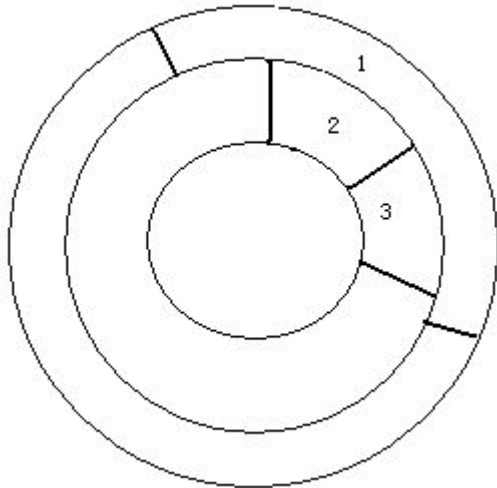

Covered is that the least countries in upper ring have covered one nation in lower ring. Especially, the least N countries in upper ring covering 1 nation in lower ring calls N *Covered*, all the countries in upper ring covering 1 nation in lower ring calls *full Covered*.

For example: 1, 2, 3, 4, 5, 6 are covering 7 in below circle map, that is 6 covering.

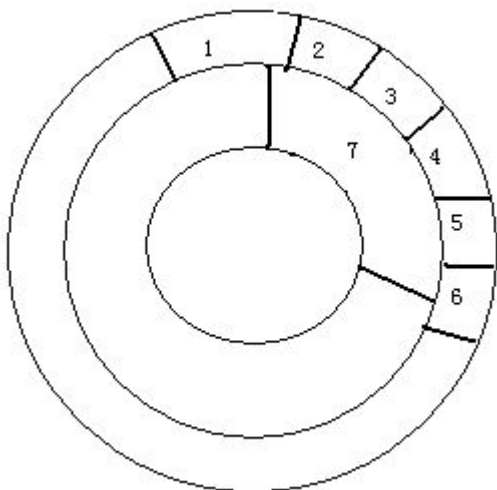

Supported is that the least countries in lower ring have covered one nation in upper ring. Especially, the least N countries in lower ring covering 1 nation in upper ring calls N *Supported*, all the countries in lower ring

covering 1 nation in upper ring calls *full Supported*.

For example: 1, 2, 3, 4, 5, 6 are supporting 7 in below circle map, that is 6 supporting.

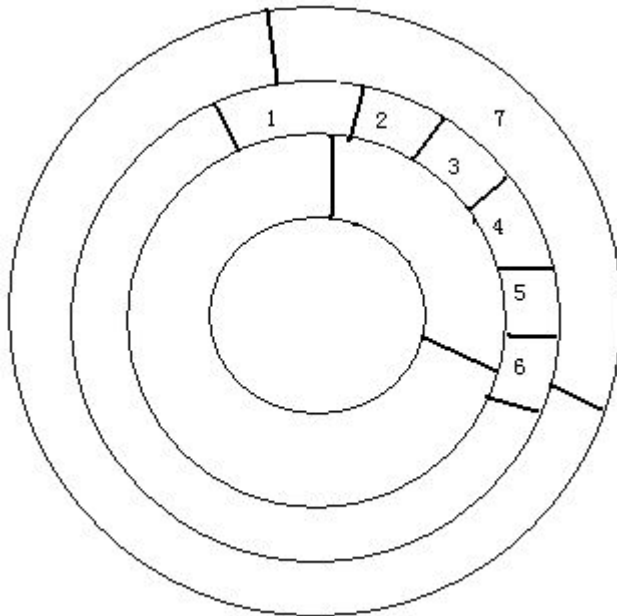

Major color is to color countries in a ring with 2 alternate colors. But if there is odd number of countries in a ring, the head and tail are the same color.

Isolating color is to isolate the same major color with 1 another color in a ring, which is of odd number of countries.

For example: We can see the example in below circle map.

Major color of ring 1 is white color and no isolate color, record as

$Major(1) = \{white\}, Isolating(1) = \{\}$;

Major color of ring 2 is red and blue color and no isolate color, record as

$Major(1) = \{read, blue\}, Isolating(1) = \{\}$;

Major color of ring 3 is black and white color and isolate color is yellow

color, record as $Major(3) = \{white, black\}$, $Isolating(3) = \{yellow\}$.

If a country can be colored by more than 1 color, it can be recode as $\{color1/color2.../colork\}$. Such as $Isolating(3) = \{yellow/green/gray\}$

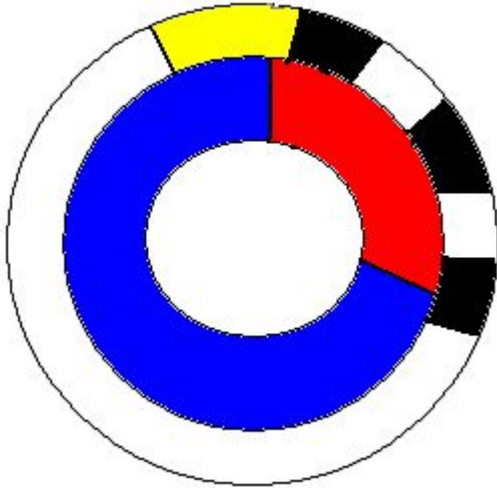

Country number is the total country number of a ring.

For example: country number of ring 3 is 7 in below circle map. Record as $Country(3) = 7$.

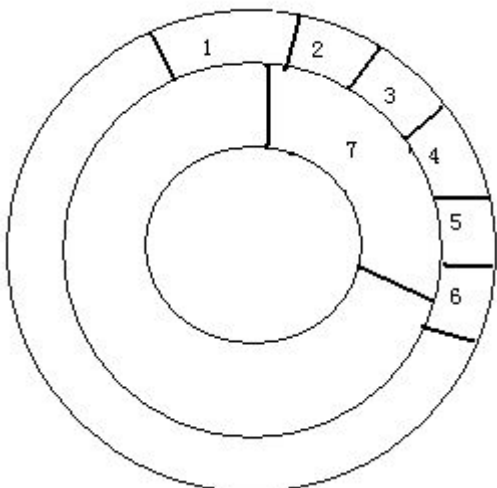

k-k adjacent countries are k countries are all adjacent. Anyone of k

country is adjacent with other $k-1$ countries.

For example: $2-2$ adjacent countries are in below circle map.

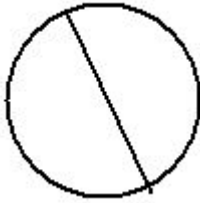

$3-3$ adjacent countries are in below circle map. Anyone country is adjacent with other two countries.

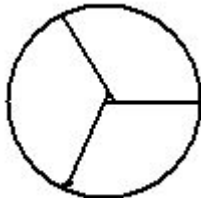

$4-4$ adjacent countries are in below circle map. Anyone country is adjacent with other three countries.

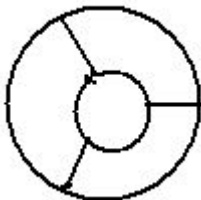

We will prove $4-4$ adjacent countries are the biggest adjacent relationship in circle map.

6. Preliminary theorem

(6.1) $4-4$ adjacent countries are the biggest adjacent relationship in circle map.

(6.1.1) Suppose $5-5$ adjacent countries are the biggest adjacent

relationship in circle map.

Base on the *4-4 adjacent countries*, let me add a new country in circle map, which is *5-5 adjacent countries*.

(6.1.1.1) The new country is in ring 1, like below circle map.

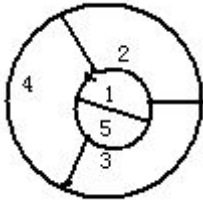

Because they are *5-5 adjacent countries*, country 1 is full covered by country 2,3,4 and country 5 is also full covered by country 2,3,4. 3 countries cover both country 1 and 5. And countries 2,3,4 are in a ring, so the overlap countries are at most 2 countries. Then the total countries in ring 2, denoted as $Country(2) \geq 3+3-2 = 4 > 3$. It's contradictory.

(6.1.1.2) The new country is in ring 2, like below circle map.

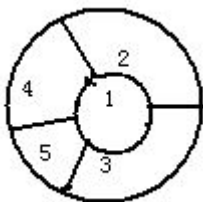

Because countries 2,3,4,5 are in the same ring 2, country 5 can be only *Boundary adjacent* with 2 countries in the same ring. But there are 3 other counties in the ring 2, so one country must be *No adjacent* with country 5.

(6.1.1.3) The new country is in a new ring 3, like below circle map.

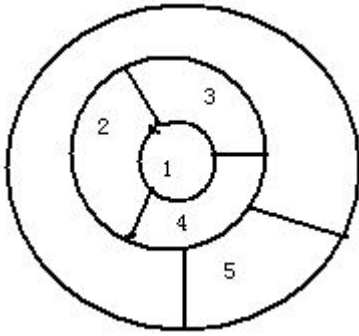

Country 5 is a new country in new ring. Obviously, country 5 is always *No adjacent* with country 1, because they are in ring 1 and ring 3 and ring 2 has insulated them.

(6.1.1.4) The new country is in a new ring k , ($k > 3$), like below circle map.

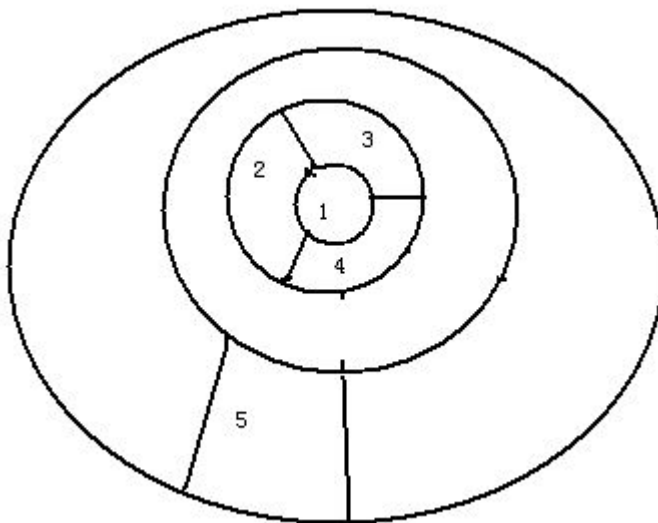

Country 5 is a new country in new ring. Obviously, country 5 is always *No adjacent* with country 1, because they are in ring 1 and ring k and ring 2 has insulated them.

All scenarios are contradictory, so supposition (6.1.1) is false and 4-4 *adjacent countries* are the biggest adjacent relationship in circle map.

7. Four color theorem

Because *4-4 adjacent countries* are the biggest adjacent relationship in circle map, and any spherical surface map can transform to circle map, then *4-4 adjacent countries* are the biggest adjacent relationship on spherical surface map and plane surface map.

(7.1) 4 color theorem

If *4-4 adjacent countries* are the biggest adjacent relationship in a map (every country is adjacent with other 3 countries), 4 colors are sufficient to color the countries.

Color strategy is that we try to use the minimum color value to color map.

The first country is colored by {1}.

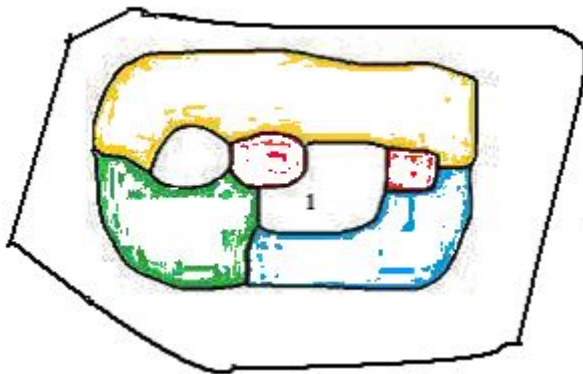

Next, we can select an adjacent country colored by {2}. If we can't find any adjacent country with country colored, new country is colored by {1}.

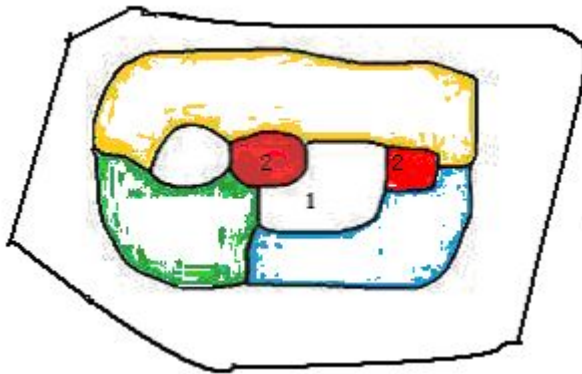
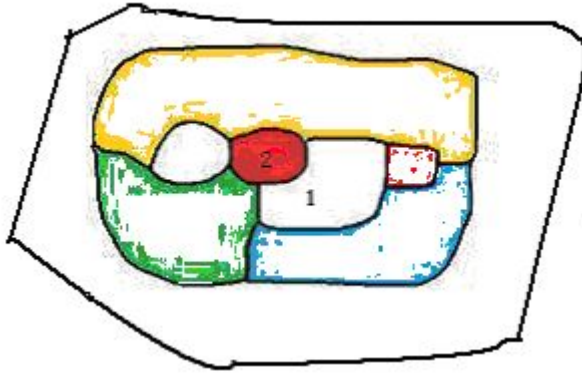

Next, we can select an adjacent country. If it is adjacent with all country colored, new country is colored by {3}. If it is no adjacent with any country colored, new country is colored by {1}. If it is adjacent with part of country colored, new country is colored by the minimum color value of countries colored.

Then we should check whether there are countries colored being no adjacent with new country colored. If yes, we should update the color as {old color/.../old color/new color}, which means the country can be colored by more than 1 color.

Last we should check whether there are old countries more colored being adjacent with new country colored. If yes, continue to check whether new color will deny the color possibility of old countries more

colored. Such as, new country color is {3}, and there is an adjacent old country colored by {2/3}, then we should update it from {2/3} to {2}, because it's adjacent with new country colored by {3}.

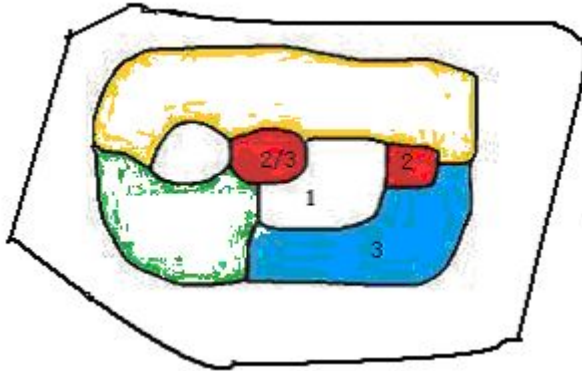

Next, we can select an adjacent country. If it is adjacent with all country colored, new country is colored by {4}. If it is no adjacent with any country colored, new country is colored by {1}. If it is adjacent with part of country colored, new country is colored by the minimum color value of countries colored.

Then we should check whether there are countries colored being no adjacent with new country colored. If yes, we should update the color as {old color/.../old color/new color}, which means the country can be colored by more than 1 color.

Last we should check whether there are old countries more colored being adjacent with new country colored. If yes, continue to check whether new color will deny the color possibility of old countries more colored.

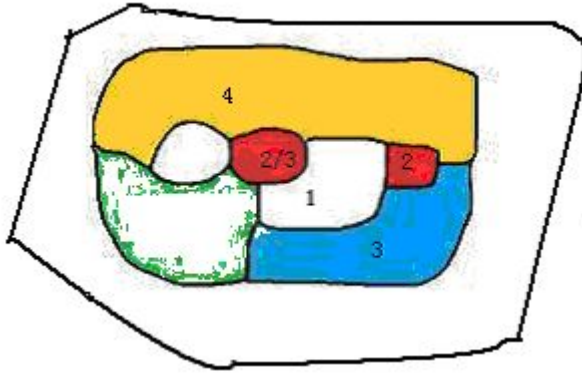

Next, we can select an adjacent country. If it is adjacent with all country colored, new country is colored by {4}. If it is no adjacent with any country colored, new country is colored by {1}. If it is adjacent with part of country colored, new country is colored by the minimum color value of countries colored.

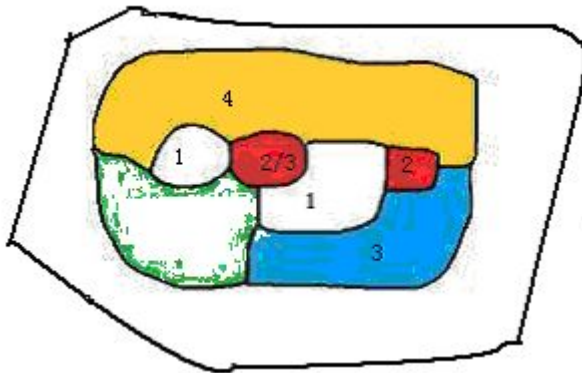

Next, we can select an adjacent country. If it is adjacent with all country colored, new country is colored by {4}. If it is no adjacent with any country colored, new country is colored by {1}. If it is adjacent with part of country colored, new country is colored by the minimum color value of countries colored.

But there are already *4-4 adjacent countries* existing, new country can't be colored by {4}. Because *4-4 adjacent countries* is the max

adjacent relations, there must be no adjacent relationship among the 5 countries (= 4-4 adjacent countries + 1 new country). Actually, the countries colored by {3} and {2/3} are no adjacent relationship. Then we can update them to the same color {3}, and new country can be colored by a no adjacent country color {2}.

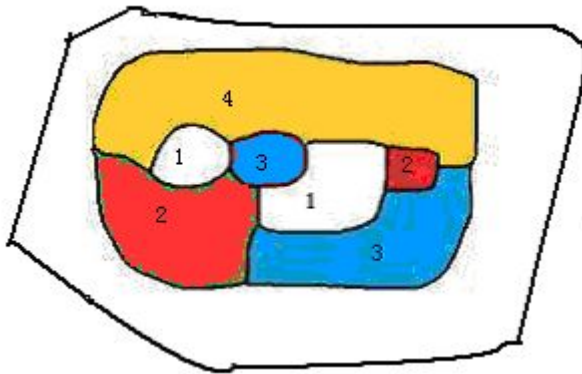

Finally, we can select an adjacent country. If it is adjacent with all country colored, new country is colored by {5}. If it is no adjacent with any country colored, new country is colored by {1}. If it is adjacent with part of country colored, new country is colored by the minimum color value of countries colored.

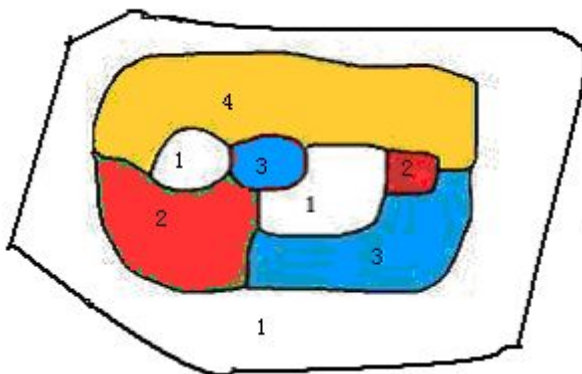

Though, the above map is simple, it has included all methods to prove

4 color theorem in any type of spherical or plane surface map. And these methods can extend to prove more complex map, such as a spherical surface with a hole.

To simplify the proof, we can conclude that when coloring a new country, we can check whether it is adjacent with *4-4 adjacent countries*. If it is no, we can color it in $\{1,2,3,4\}$; if it is yes, because *4-4 adjacent countries* are the max adjacent relationship, we can always find a no adjacent country. Then we can update the no adjacent countries into the same color, and color new country still in $\{1,2,3,4\}$.

8. K color theorem

With the proof methods, we can deduce k color theorem on any type of surface.

(8.1) K color theorem

If *k-k adjacent countries* are the biggest adjacent relationship in a map (every country is adjacent with other k-1 countries), k colors are sufficient to color the countries.

It is similar to above proof, before we color a new country, we can check whether it is adjacent with *k-k adjacent countries*. If it is no, we can color it in $\{1,2,3,\dots,k\}$; if it is yes, because *k-k adjacent countries* are the max adjacent relationship, we can always find a no adjacent country. Then we can update the no adjacent countries into the same color, and

color new country still in $\{1,2,3,\dots,k\}$.

9. Conclusion

Four-color theorem is an interesting phenomenon, but there is a rule hidden the phenomenon. The biggest adjacent relationship on a surface decides how many color enough. K-color theorem is a deducing from it.