

The Shnoll Effect explained by Quantum FFF theory.

Leo Vuyk,
Architect,
Rotterdam, the Netherlands.

Abstract,

Quantum Function Follows Form (Q-FFF) theory states, that the vacuum is seeded with fast oscillating massless dual Higgs particles, oscillating along a complex chiral truncated tetrahedral vacuum lattice, which has the ability to transfer Photon and Graviton information in bunches of oscillations, through the vacuum lattice with the local speed of light.

As a consequence there are no attraction forces on Fermions, which are supposed to have a real propeller shape and real double axis spin.

Higgs oscillations are the origin of all energy processes in the universe and the origin of so called Dark Energy.

NON oscillating Higgs particles are supposed to be trapped inside black hole nuclei of variable sizes called “Quantum Knots”, and the origin for all Dark matter.

Only the sum of the different kinds of vacuum impulses in the form of Higgs vector arrays from all directions on Fermions are responsible for all energetic phenomena and gravity in the universe.

However, the vacuum lattice has only $2 \times 6 = 12$ (twelve) oscillation directions, which seem to be observed in the 27 day sidereal moon related period of similar histograms found by Simon E. Shnoll.

These periods of 27 days seem to show a split in 2 or 3 subgroups of similar histograms, which have a possible relation with the 12 oscillation directions of the vacuum with cubic and hexagonal elements..

As a second consequence, all “eigen energy” (even nuclear decay) and spin of Fermions is the result of the Dark Energy Higgs vector Field (DEHF) collision process with Fermions

As a third consequence Solar, Planetary and Moon masses influence the DEHF by less powerful Graviton vector array information transfer, which is assumed to be the origin of peculiar Shnoll effects like Solar and Sidereal day periods, sidereal Moon periods and year periods of similar histograms of nuclear decay measurements like Plutonium, ^{239}Pu .

Michelson-Morley didn't find the ether, BUT Simon Shnoll did!

Introduction.

It was Georges Louis LeSage (1748) who designed a new model for gravity, which is a kinetic theory of gravity originally proposed by Nicolas de Duillier in 1690.[ref. 1]

According to Le Sage gravity the vacuum is also seeded with fast **travelling** corpuscles, impinging on mass carrying particles present inside massive bodies. The deflection of these vacuum particles after the impulse on the first body, should lead to a decline in vacuum pressure on a second object, tending to drive two bodies together.

However, Quantum FFF theory suggests in contrast, that the vacuum is seeded with fast **oscillating** energetic (121-130GeV) but massless Higgs particles, oscillating along a complex chiral universal tetrahedral vacuum lattice, which has the ability to transfer Photon- and Graviton information in bunches of oscillations, through the vacuum lattice with the local speed of light.(fig 4)

As a consequence **there are no attraction forces** on the propeller shaped spinning Fermions. Only the sum of the different kinds of vacuum impulses from all directions on Fermions coined: “Higgs Vector arrays” of different particle information, are responsible for all energetic phenomena in the universe.

Thus we could give such a gravity model the name: “**Double Le Sage gravity**”.(figure 1,8)

Fermions are assumed to be fast spinning 3 Dimensional propeller shaped strings, able to deform impinging Higgs particles by collision into 5 different shaped 3-Dimensional Photon/Gluon particles and Gravitons. (Figure 2, and Ref. 4,5).

In contrast with the contemporary “standard model”, I count two Gluon/Photons (coded: LOL+ROR) for the electric quantum force, two Gluon/Photons (LOU+ROU) for the magnetic quantum force and one Gluon/Photon (UOU) as general particle for the x-ray, gamma ray and different light frequencies.

The 5 different shaped Gluon particles (Ref.4,5) are in contrast with Gravitons, supposed to be able to merge with Fermions into more complex compound Fermion particles (Quarks, including Muons and Tau Fermions). However if no Fermions are hit, then after a very short (Planck) distance the Gluon information is picked up and transferred as also 5 different coded Photon information by the Higgs system, simultaneous along different Lattice routes in the form of a bunch of entangled Higgs oscillations. (figure: 4) as explanation of the so called particle-wave duality.

So, all 5 Gluons change only their name but not their form into 5 Photons at more than the Planck distance from the source.

The Shnoll effect. [Ref 2]

The local “Double Lesage Gravity” vector arrays (fig 1,8) inside the Higgs vacuum lattice are supposed to be responsible for phenomena like the Shnoll effects. (Solar- Moon- Stellar and Palindrome effect).

The direction and strength of the gravity influence of the Sun, moon and the galaxy combined with the reference frame of the vacuum lattice itself seem to be all observable in the measurement results.

The 27 day sidereal moon related period of similar histograms found by S.Shnoll, seem to show a split in 2 or 3 subgroups of similar histograms. (fig. 13)

These subgroups are supposed to be a support for a DOUBLE truncated tetrahedron 3D polarisation of the vacuum lattice as reference frame with CUBIC and HEXAGONAL lattice directions.

Michelson-Morley didn't find the ether, BUT Simon Shnoll did!

Quantum Gravity as pressure distribution of the oscillating dual Higgs/Graviton vector field.

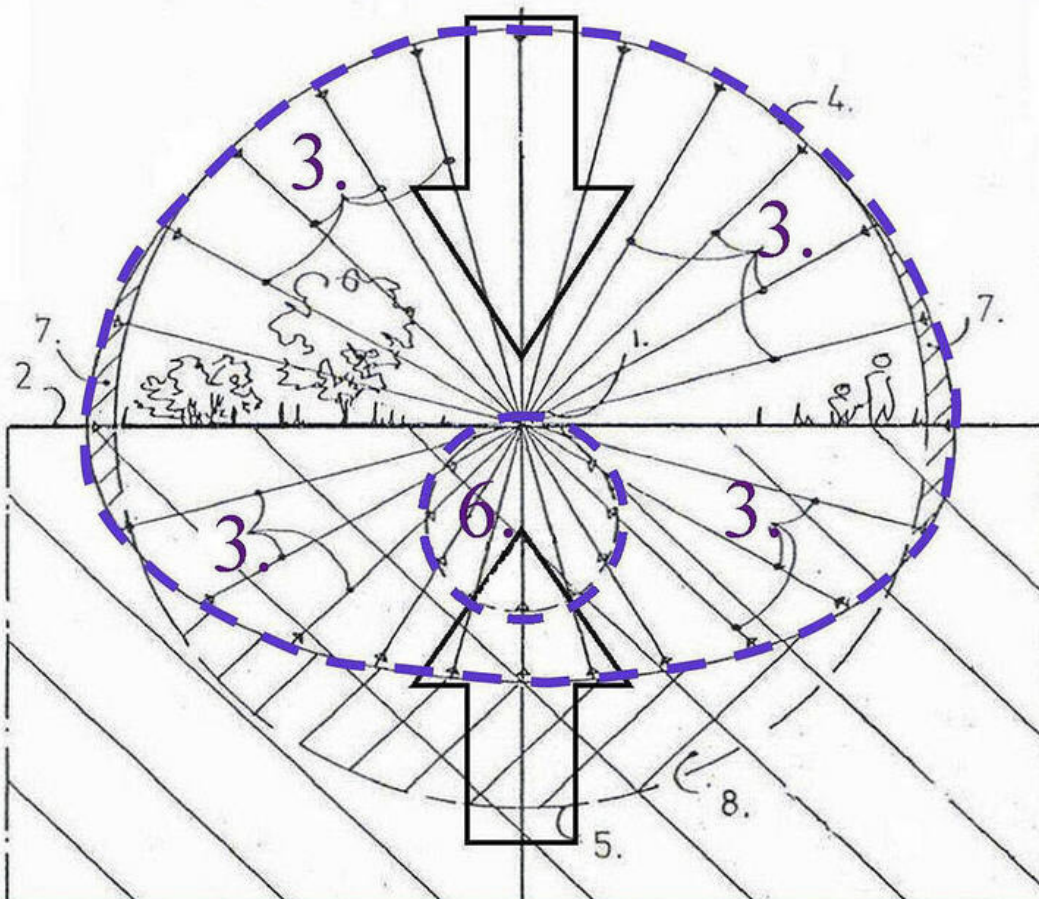

Cross section through the dual Higgs/ Graviton 3D vector field pressure distribution (or globular Hedgehog) on a point mass (1) located on earth's surface (2), according to Quantum FFF theory. 3+4= Higgs vector field. 6= Graviton vector field originated by the Higgs-graviton field transformation of the earth itself. 7+8= differences with a perfect globular vector distribution. Field variables 3+6 are rendered as inversed arrows. (see also black hole pressure distribution without gravitons)

Figure 1, Higgs Graviton vector array field pressure distribution around a test mass at the earth surface.

Explanation of the codes:

- U= Up rotation (180 degrees)
- O= Unchanged circle.
- L= Left rotation (90 degrees)
- R= Right rotation (90 degrees)

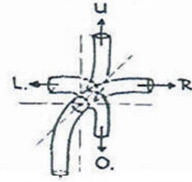

Summary with oscillation routes : (↔) or the definite Graviton decay route (→).

Spin 0 particle:

Spin (2) particles:

Spin 1 particles:

Only These particles are building - blocks for Quarks.
Direct W. quark oscillations $d \leftrightarrow s$.

Spin 1/2 particles

Weak interactions

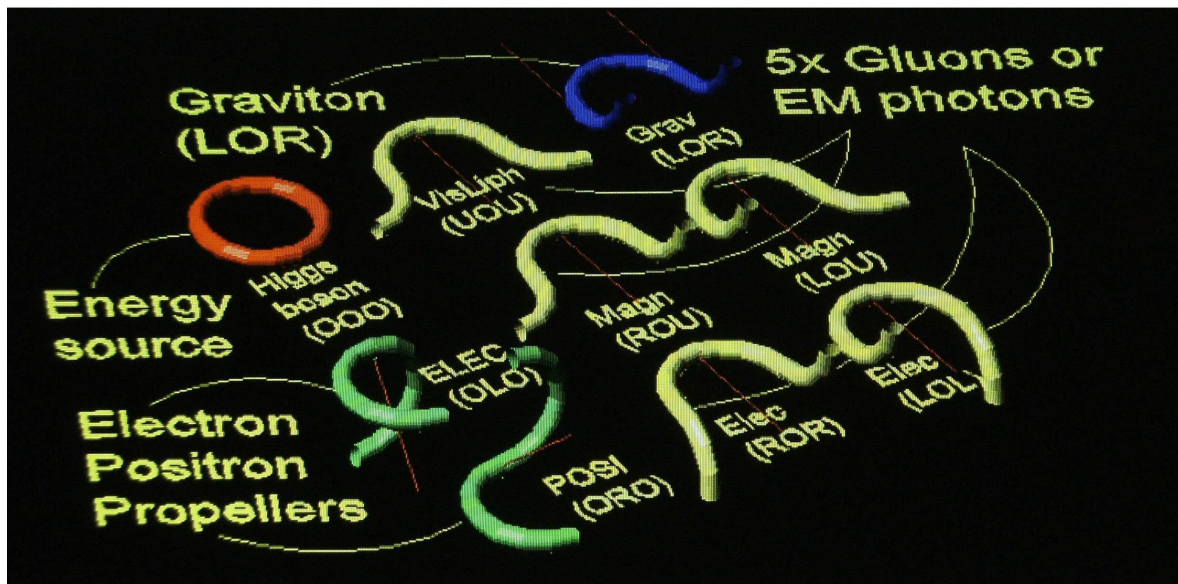
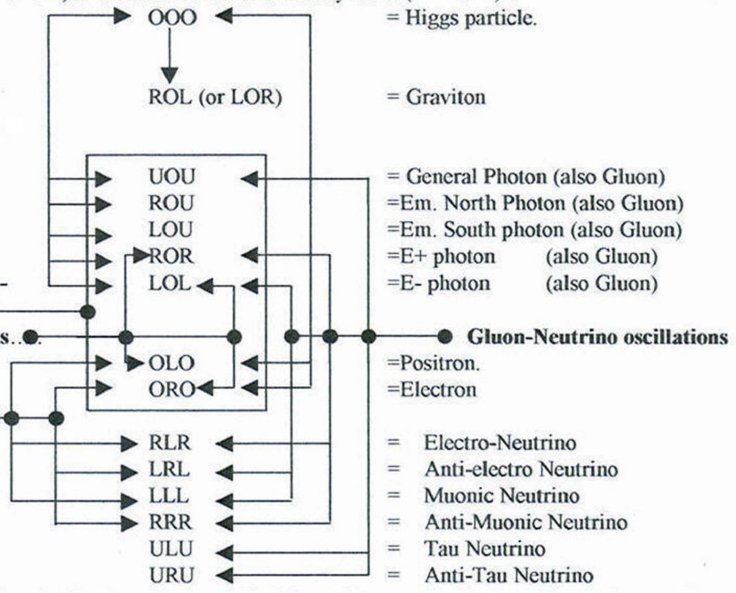
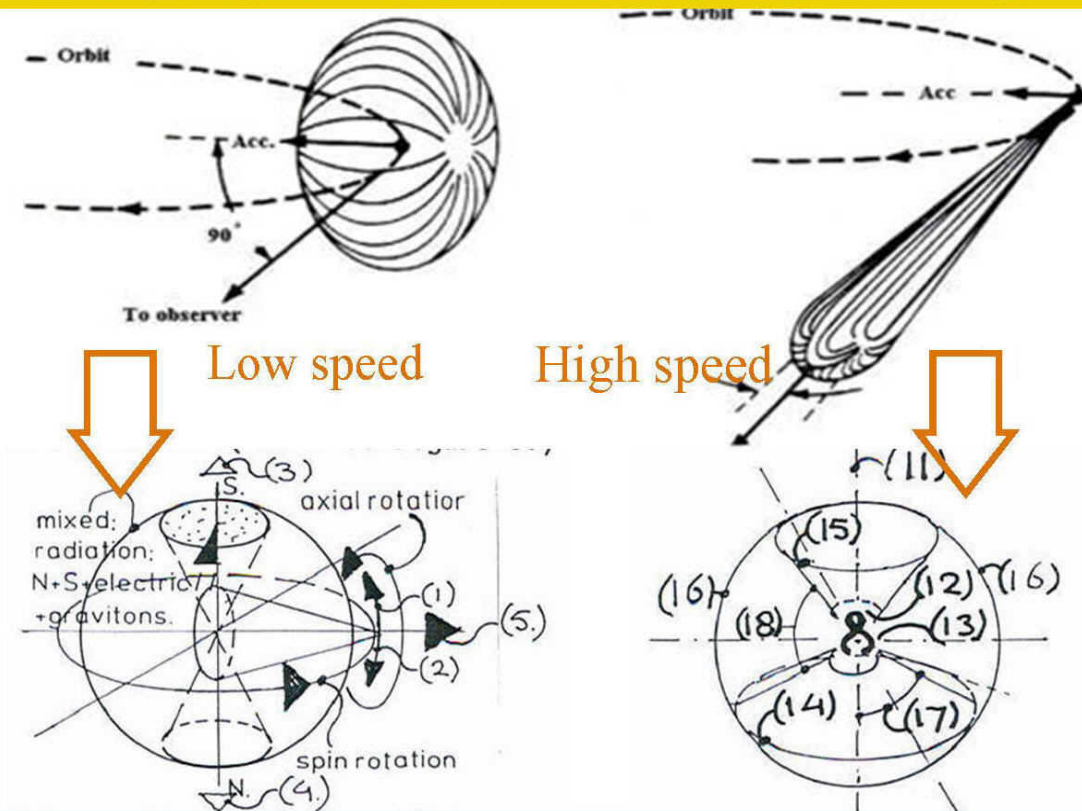
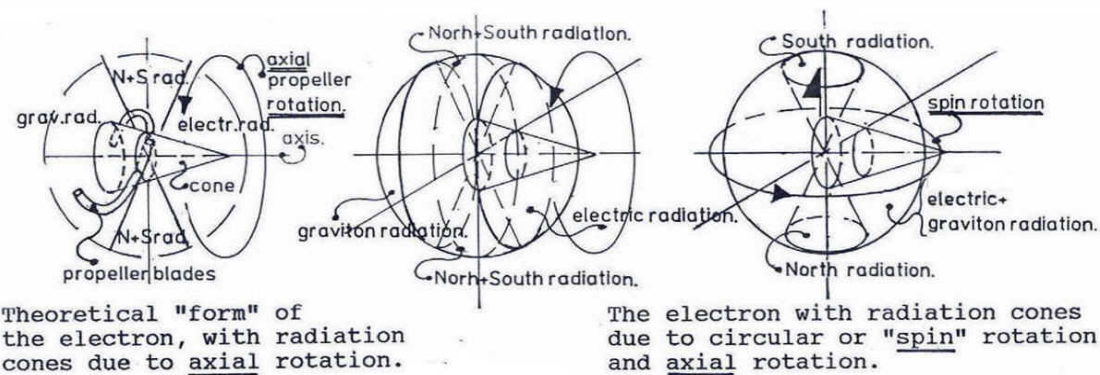

Figure 2, 3-Dimensional String Based Alternative Particle Model. Of single particles. (Ref. 3) Quarks and some leptons are composite particles.

Synchrotron radiation by Polarized Fermion spin combined with high speed motion through the resistive oscillating Higgs vacuum (according to Quantum FFF theory)



The propeller shape of Fermions is the origin of a dual spin state by collision influences of the oscillating massless Higgs vacuum at low speeds. (Spin rotation and axial rotation) At high relativistic speed the Lorentz polarization of the Fermion "propeller nose" (1 or 2) is preferentially pointing into direction (11) with synchrotron radiation cone focussing (15) into the opposing vacuum direction and the Spin rotation has gone.



Theoretical "form" of the electron, with radiation cones due to axial rotation.

The electron with radiation cones due to circular or "spin" rotation and axial rotation.

Figure 3, Double axial spin of Fermions with monopole Gluon- Graviton radiation cones. After a short Planck distance the 5x radiated string shaped Gluons (2 Electric, 2 Magnetic and one general) can merge with Fermions into composite Quarks, or become a photonic wave, just like the Graviton.

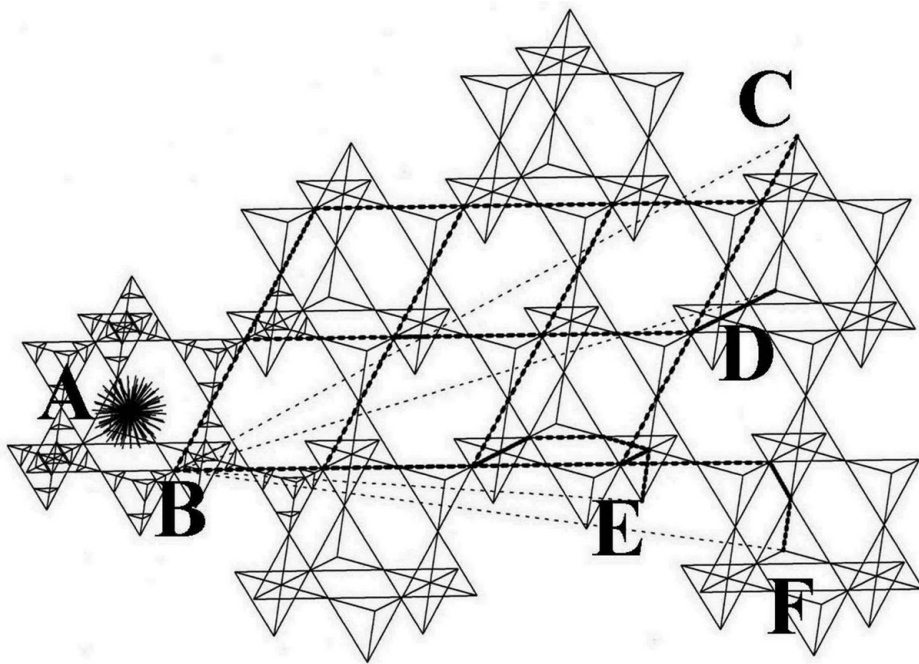

Photon trajectories through the tetrahedral Chiral vacuum lattice.

A photon is created as a deformed Higgs particle at position (A), thus as a single (Photon/Gluon) particle which after some distance changes form back into a Higgs particle (B).

The photon energy is transferred into the oscillating Higgs system and travelling through the vacuum lattice in the form of a BUNCH of entangled energetic Higgs oscillations with the local speed of light.

(To match the single photon double slit experiment)

After collision with a second Fermion, at locations C,D,E,F. the BUNCH of energy collapses and change the FORM of a local Higgs particle into the shape of the original Photon.

Five different shaped Gluons after some distance are called Photons.

Thus five different shaped Photons start their journey as Gluon. Author: Leo Vuyk.

Figure 4, Photon (bunch shaped) trajectories, through the Higgs vacuum lattice.

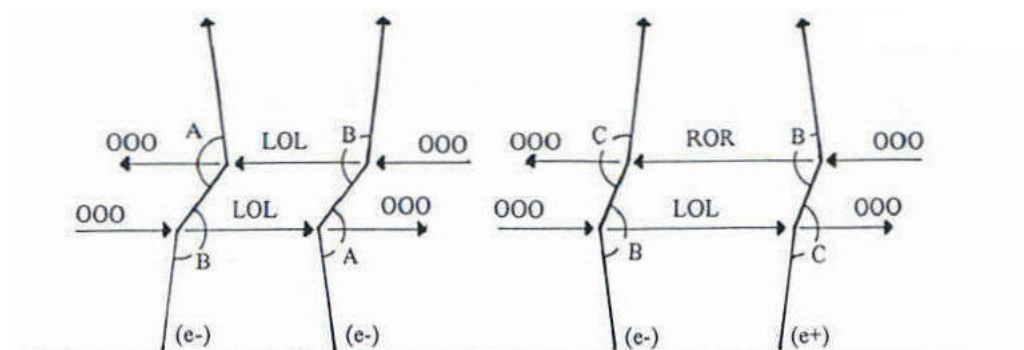
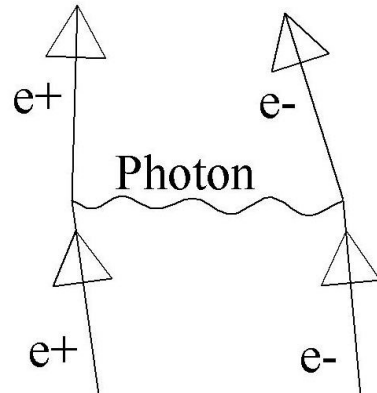

Figure 5, The principle of electric field force transfer by two monopole electric Photons (LOL and ROR) pushing Fermions with different impulses between two equal charged Fermions and different charged Fermions. The impulse of the Higgs particles is supposed to play an important role in combination with the monopole Photons to deflect the Fermions out of their trajectory.

A comparable system is supposed to be active for Gravitons. (Figure 1,8,9)

Feynman diagram for Electron Positron attraction, compared with Quantum FFF Theory repulsion solution.



Higgs Impulse diagram for ELECTRIC monopole radiation, according to Quantum FFF theory.

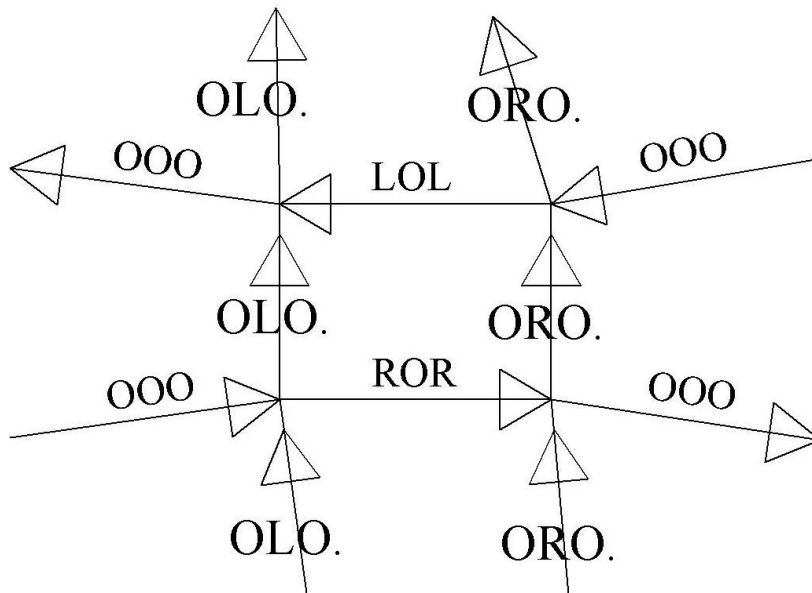

Fermionic impulse differences between Higgs (OOO) and TWO Electric monopole Gluon/Photons (LOL and ROR) on Fermions (OLO and ORO).

OOO changes form after collision with OLO resp ORO into ROR resp LOL and after second collision back again into OOO.

Figure 6, Comparison between electric Feynman diagram and Q-FFF Theory

Higgs Impulse diagram for MAGNETIC monopole radiation, according to Quantum FFF theory.

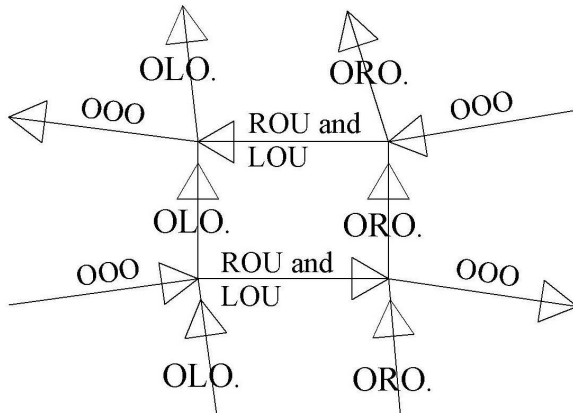

Fermionic impulse differences between Higgs (OOO) and TWO Magnetic monopole photons (LOU and ROU) on Fermions (OLO and ORO).
 OOO changes form after collision with OLO resp ORO into ROU and LOU and after second collision back again into OOO.

Figure 7, Magnetic monopole collision process.

Higgs impulse diagram for Double LeSage Gravity, according to Quantum FFF theory.

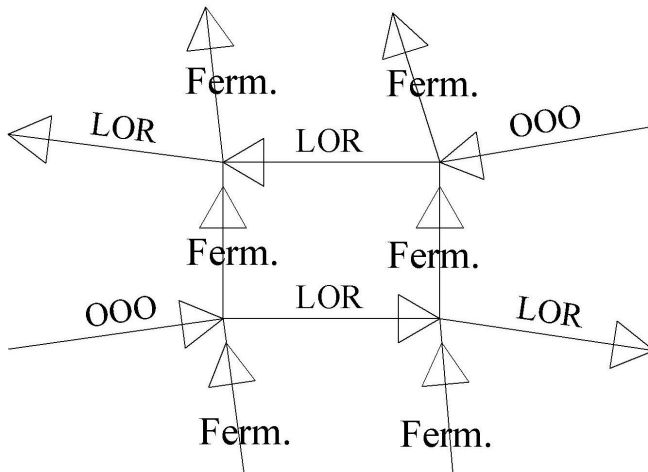

Fermionic impulse differences with Higgs (OOO) and pushing Gravitons (LOR).
 OOO changes form after collision into LOR.
 Gravitons don't change shape after collision.

Figure 8, The principle of the **Double Le Sage gravity** force transfer between two Fermions. The impulse of the Higgs particles is supposed to be larger than the Graviton Impulse.

Higgs/Graviton pressure vector hedgehogs acting on a mass carrying Quantum particle. The irregular distribution of mass inside the earth is supposed to influence the 3D pressure vector hedgehog according to the new Double LeSage gravity paradigm, see image below.

Author Leo Vuyk.

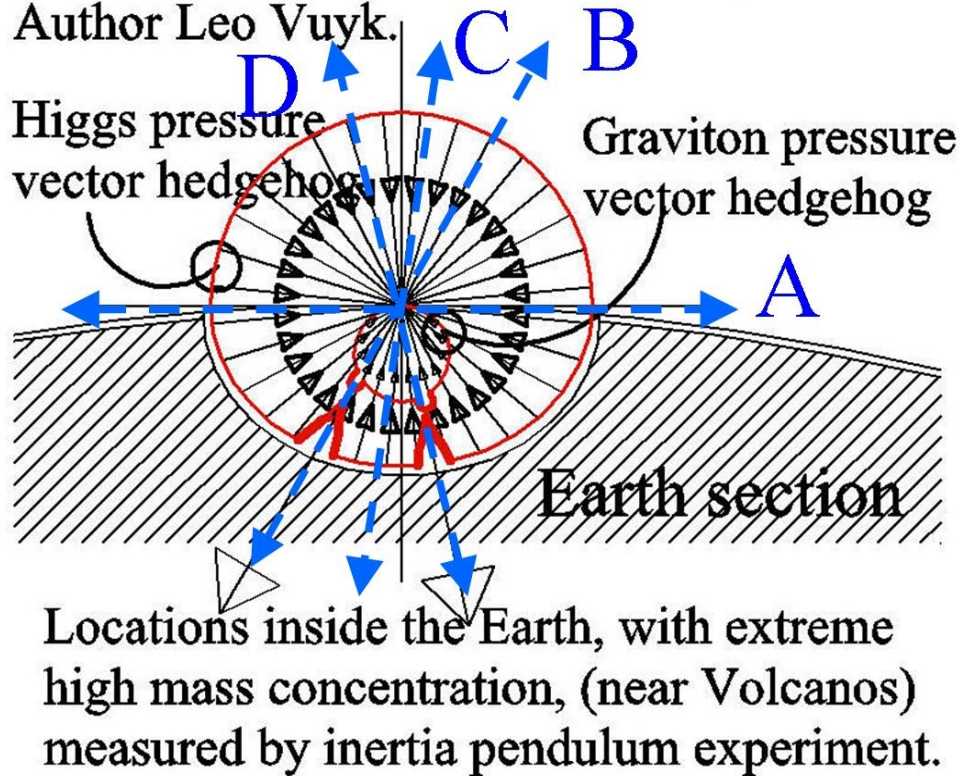
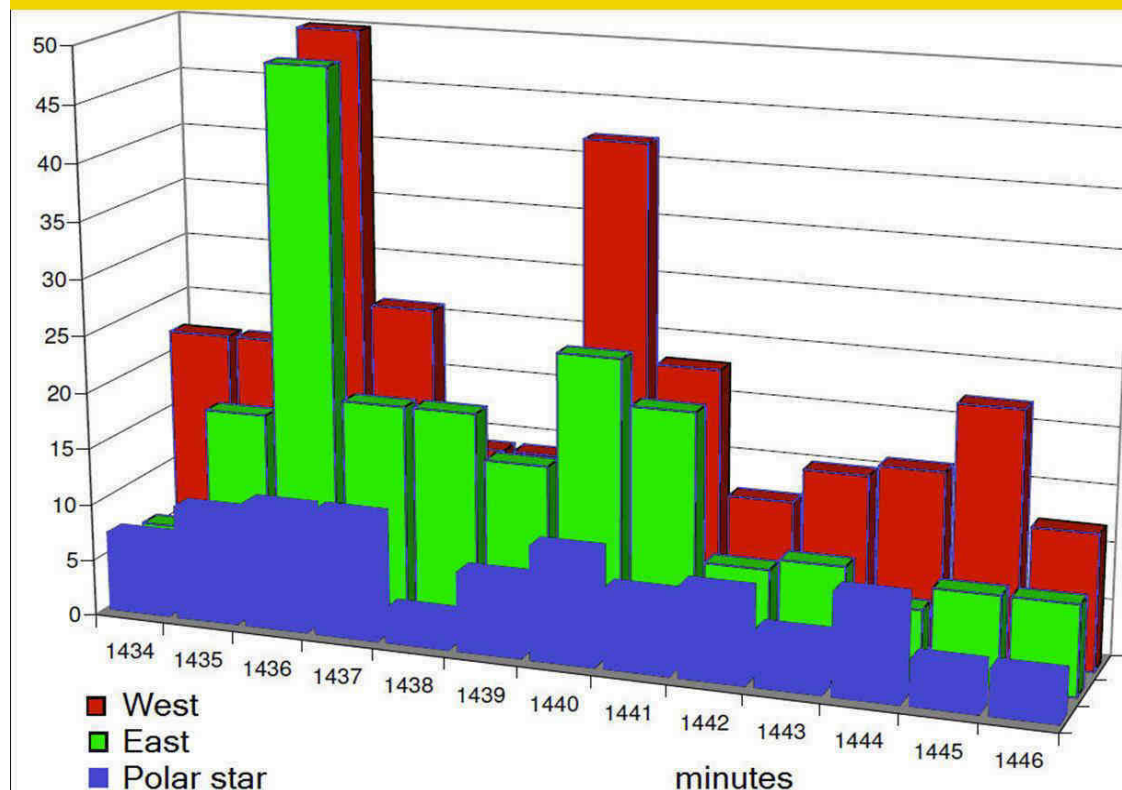

Figure 9,

The “Double Higgs Vector Hedgehog” related to mass concentrations in the earth. Oscillation directions: A,B,C and D will give larger damping differences as expected by Newtonian gravity rules.

The Shnoll effect and Space anisotropy, explained by Quantum FFF theory (1)

According to Quantum FFF theory, the real structure of space is described by a truncated tetrahedral chiral oscillating Higgs lattice. Stellar- and Galaxy Anchor black holes (GABHs and SABHs) are the main origin of polarization of the Higgs vacuum lattice into Higgs-Dark Energy Vector Fields, responsible for all energy phenomena like the Shnoll effects. (Solar- Stellar and Palindrome effect)



It can be seen that when a light beam is directed towards the Polar Star (BLUE) no day period is present, and when it is West- or East directed, day periods (“star days” — 1,436 minutes and “Sun Days” — 1,440 minutes) are expressed very distinctly. X-axis is periods (minutes); Y-axis is numbers of similar histogram airs correspondent to the period value. (from Progress in Physics July 2012. I.A Rubinshtein et.al.)

Figure 10, presentation of the numbers of similar histograms presented by I.A.Rubinstein. in Progress in Physics, July 2012.. The minor similarity of the Polar star directed light beam at 1438 seconds could be the result of Higgs dark energy vector array influence of the Stellar Anchor Black Hole (SABH).

According to Quantum FFF theory, the real structure of space is described by a truncated tetrahedral chiral oscillating Higgs lattice.

Stellar- and Galaxy Anchor black holes (GABHs and SABHs) (fig 11 and 12) are the main origin of Dark Energy polarisation of the Higgs vacuum lattice into Higgs-Dark Energy Vector Fields. (DEHFs)

However as described before, Local Gravity fields are supposed to influence the relation between the Higgs and Graviton vector array fields inside the vacuum lattice as depicted in figures: 1 and 9.

As a consequence,

A; the GABHs and SABHs are responsible for the Dark energy and Electro magnetic Birkeland currents and Alfven circuits observed in the solar system and the galaxy.

B: the local gravity vector arrays inside the Higgs vacuum lattice are supposed to be responsible for phenomena like the Shnoll effects. (Solar- Moon- Stellar and Palindrome effect)

Michelson-Morley didn't find the ether, BUT Simon Shnoll did.

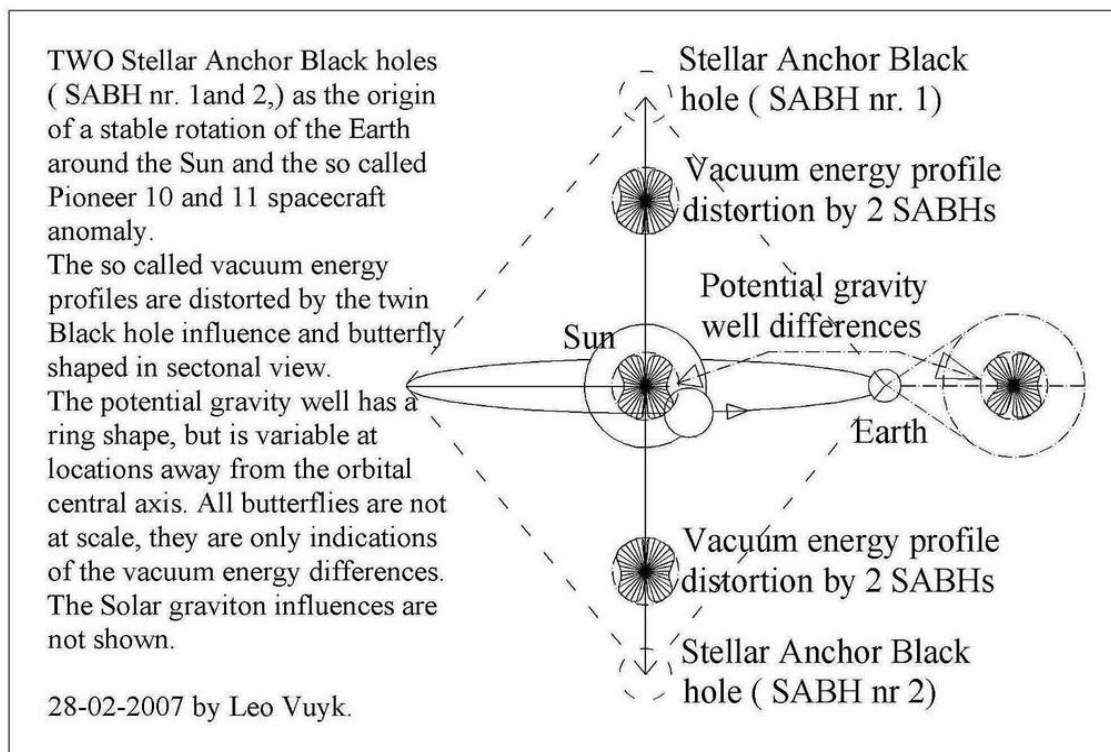
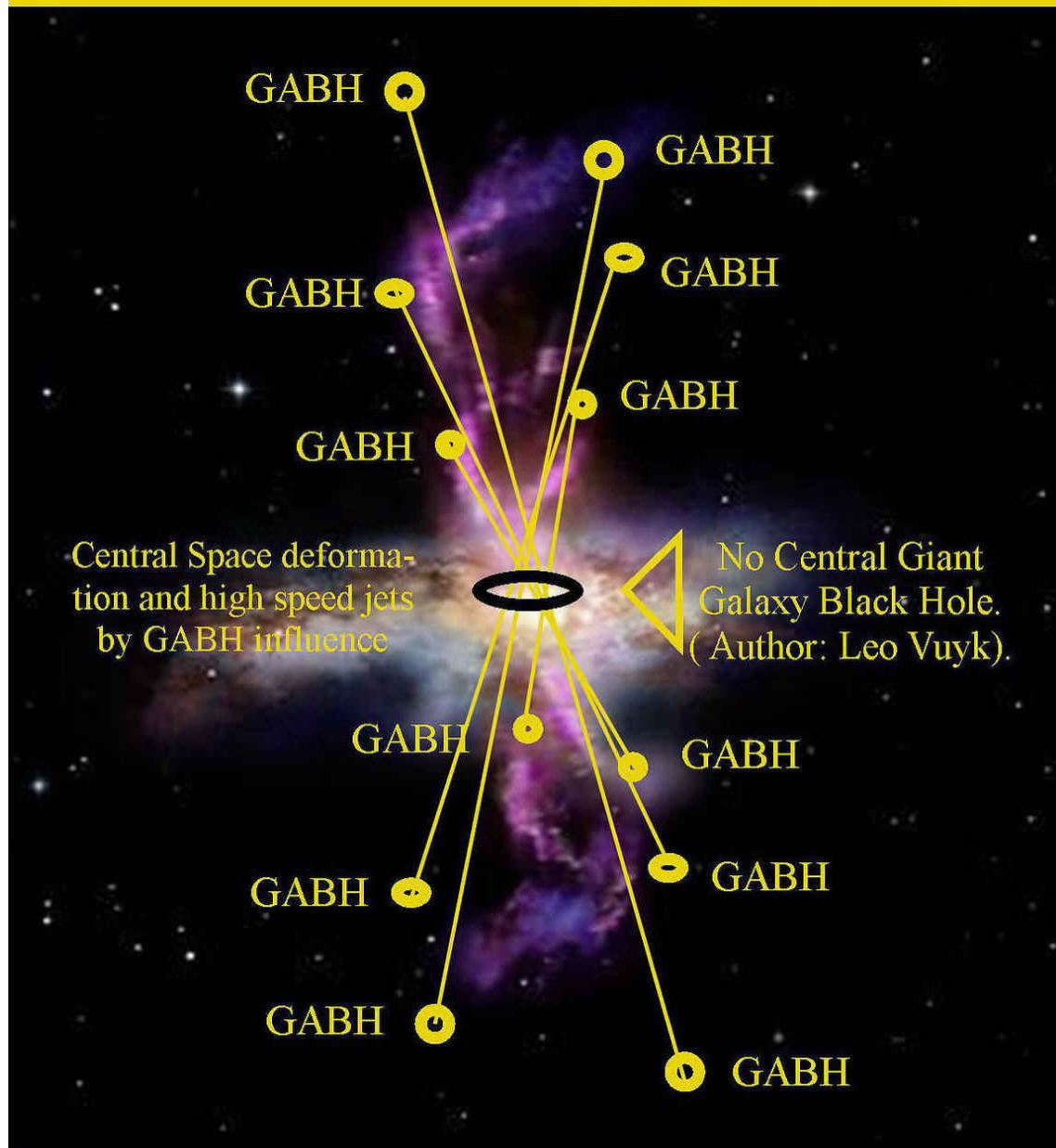

Figure 11, Dark Energy Higgs vector arrays around the sun influenced by the polar SABHs.

Galaxy Anchor Black Hole (GABH)- Effect on High speed gas ejection.



Massive molecular outflows and negative feedback in ULIRGs observed by Herschel-PACS

Figure 12, Galaxy Anchor Black Holes (GABHs) signatures in a so called Ultra Luminous Infra Red Galaxy. (ULIRG)

The Shnoll effect and Space anisotropy, explained by Quantum FFF theory (2)

According to Quantum FFF theory, the real structure of space is described by a truncated tetrahedral chiral oscillating Higgs lattice. Stellar- and Galaxy Anchor black holes (GABHs and SABHs) are the main origin of polarization of the Higgs vacuum lattice into Higgs-Dark Energy Vector Fields, responsible for all energy phenomena like Gravity which are all observed in the Shnoll effects. (Similarity of histogram shapes with periods related to Moon Solar- Stellar orbital reference frames) .

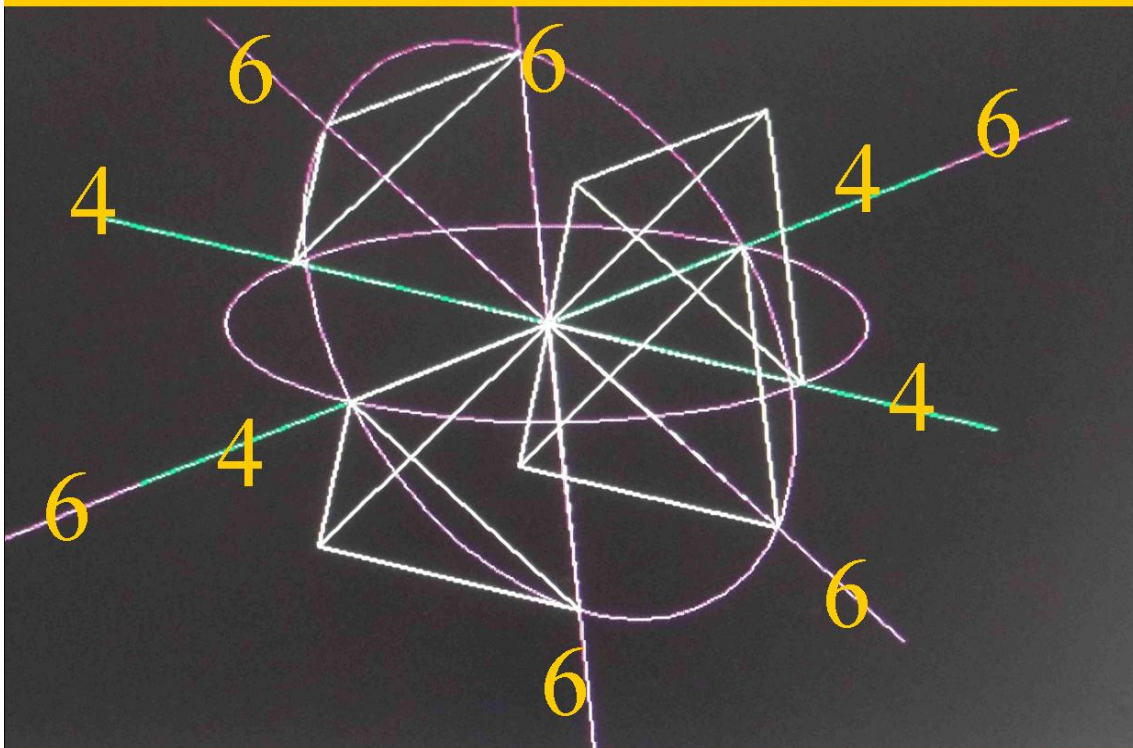

Shnoll et al found a non gravity related ANOMALY of a 2 or 3 periodicity within the 27 day moon orbital period around the earth. This anomaly is supposed to be originated by the possible temporary 2 or 3 vacuum axis crossings of a circular moon orbit within a DOUBLE truncated tetrahedral vacuum structure. Only such a system can contain a CUBIC AND HEXAGONAL vacuum structure (see image above with 4x and 6x circle crossings)

Figure 13 , Q-FFF proposal for the solution of a non gravity MOON related anomaly with a 27 days periods split in 2 to 3 “sub periods” found by S.Shnoll et al.

This anomaly is a strong indication for a vacuum lattice system with a cubic and hexagonal structure oriented in different 3D directions.

References:

[1] LeSage theory of gravity:

http://en.wikipedia.org/wiki/Le_Sage's_theory_of_gravitation

[2] Simon E. Shnoll, Cosmophysical Factors in Stochastic Processes.

<http://shnoll.ptep-online.com/publications.html>

[3] [viXra:1103.0011](#)

An Alternative Black Hole, Provided with Entropy Decrease and Plasma Creation.

Authors: Leo Vuyk

Category: [High Energy Particle Physics](#)

[4] [viXra:1103.0002](#)

3-Dimensional String Based Alternative Particle Model.

Authors: Leo Vuyk.

Category: [High Energy Particle Physics](#)

[5] [viXra:1102.0052](#) 27 **Construction Principles for Chiral "atoms of Spacetime Geometry".**

Authors: Leo Vuyk

Category: [Quantum Physics](#)

[6] **The New God Particle and Free Will.**

By Leo Vuyk, LuLu publishers, 2008.

ISBN number 978-1-4092-1031-3