

# Weyl Scale factor as a global dynamic variable in physics to eliminate the infinities in Quantum Theory

© Q PAN

TOKU-E Foundation

qpan@TOKU-E.com

## Abstract

In the Quantum Electrodynamics (QED), the perturbation propagators do not all have the same Weyl scale weight when integration is carried out over all momentum spaces. A dynamic scale factor is introduced to all dynamic variables in physics in this paper. The requirements for physics equations, including the Maxwell equations to be invariant under scale factor transformation is investigated. If a Planck type term with energy momentum dependence (not coordinate dependent) as scale factor is introduced to the propagator of QED, the renormalization theory is no longer needed. Instead of inventing different scheme of removing infinities, more experimental data collection is needed to determine the scale factors for different scenarios. The scale factor can also be introduced through replacing the momentum by a re-gauged momentum. Another approach of introducing the scale factor is to replace Fourier Transformation by Laplace Transformation in all quantum mechanics. The quantum gravity self-interaction terms shall no longer be infinite by choosing different scale factors.

**Key Words:** Renormalization, Weyl theory, Planck distributions, curved momentum space, Laplace Transformation, and quantum gravity

## 1. Introduction

Quantum mechanics and relativity theory are the two great discoveries of the 20<sup>th</sup> century in physics. The quantum electrodynamics is the application of quantum theory into the electromagnetism. There are limited number infinities in the perturbation theory of quantum electrodynamics which are removed through the renormalization theory (*Ref.1*). A very straight forward next step in modern physics would be applying the quantum theory into gravitation, the quantum gravity. Unfortunately, in the quantum perturbation theory of gravitation there are many different infinities which was not able to be renormalized (*Ref.2, 3*).

Even though the super-string theory does not suffer from ultraviolet divergences caused by shrinking one of the internal lines of Feynman diagram to zero. But the string theory up to date is still a mathematical collection of folklore, rules of thumb, and intuition (*Ref.4*).

As we recall, in the early development of the theory of quantum mechanics, in the blackbody radiation theory there is also ultraviolet divergence. The Planck term with exponential convergence in the blackbody radiation was introduced to describe the elementary particle behavior which is different from that of macro objects. The author thinks that a new theory by re-visiting the emitting property of virtual particles of current quantum theory may lead to a rediscover of the quantum interior structure of elemental particles.

Within the current quantum physics domain, because the perturbation terms are a combination of energy-momentum terms  $k^n$  where  $n$  is integer of a greater than zero or less than zero, there is no way to remove the infinities when integrate the perturbation term over all energy momentum because the integrand goes to infinite when  $k$  goes to infinite (zero) when  $n$  greater than zero (less than zero). The best way to solve these infinite problems is to **re-introduce** the Planck type term to all perturbation theory of QED, QCD and Quantum Gravity. But the current physics equations does not allow to introduce such a term.

Also, in the quantum mechanics domain, the electron in the atom does not radiates the electromagnetic waves in the ground state. The Feynman diagram of free electron emits virtual particles and re-absorbed. To maintain the electron in

the ground states and to be consistent with the classic theory of electromagnetism, as extension of blackbody radiation theory, the virtue particles emitted shall be limited to a certain pattern in related to the wavelength just like the blackbody radiation, not equal opportunity for all energy-momentum of virtual particles. But the Dirac Theory does not have the possibility to add another term in the perturbation theory. In this paper, section 2, we would like to propose a new Weyl-type of scale factor which allow a new Planck type term is introduced into all physics variables.

Section 3 to section 7, all possible scale factor is analyzed for different physics equations. This new scale factor will be convergent in the ultraviolet limit and infrared limit. Just like the quantum mechanics, this Planck type of term can be used to study the virtue particle relationship with the elemental particles and hopefully this scale factor can be used to study the sub-structure of elemental particles.

Dirac and many other authors have introduced the Weyl theory to gravitation and cosmology (*Ref.5,6*). The interpretation of Weyl gauge field has not been properly defined in different area of physics. When Weyl introduce the gauge field, the field is introduced through geometrical object, the metrical tensor to transform like  $g_{\mu\nu} \rightarrow \lambda^2 g_{\mu\nu}$  to make affine connection invariant. It is equivalently,  $d^2s \rightarrow \lambda^2 d^2s$ .

$ds$  has much more implication in physics than metric tensor which is used as a geometrical representation of gravity. To the author that  $\lambda$  may connect different inertial system as a global variable.

Thought experiment: A physicist A in the laboratory, chose to accelerate an electron, the electromagnetic field path through a thought membrane (a) around the electron is adsorbed by the electron. Another physicist B try to accelerate the laboratory, large amount of gravitational field pass through the thought membrane (b) around the laboratory, which exclude the electron and the membrane (a). To an observer C sitting on the membrane (a), sees no field pass through his membrane (a) when physicist B accelerate the laboratory. Both systems are equivalent kinematically to the observer C if observer C does not care about the history of field passing through the membrane. This "hardness" difference between physicist A and B as well as the history of field passing

through the membrane (a) may mean a global property difference of the inertia system reflected by  $\lambda$ . In the later section of this paper, we will define a scale weight based on  $ds$  to re-visit most of the dynamic variables and some of the field equations.

## 2. The scale factor for different variables

Weyl theory defines the metrical tensor transformation as following:

$$g_{\mu\nu} \rightarrow \lambda^2 g_{\mu\nu}$$

where  $\lambda(x, p)$  is a complete arbitrary scalar function of position or momentum.  $\lambda(x, p)$  can be a complex number in order to also include the phase factor of quantum mechanics. A variable  $Z$  is invariant under this transformation shall not change (Weyl co-tensor weight 0), or  $Z \rightarrow \lambda^0 Z = Z$ .

The affine connection:

$$\Gamma_{\mu\nu}^{\alpha} = \left\{ \begin{matrix} \alpha \\ \mu\nu \end{matrix} \right\} + \delta_{\mu}^{\alpha} \phi_{\nu} + \delta_{\nu}^{\alpha} \phi_{\mu} - g_{\mu\nu} g^{\alpha\beta} \phi_{\beta} \quad (1)$$

is invariant under transformations

$$g_{\mu\nu} \rightarrow \lambda^2 g_{\mu\nu} \quad (2.1)$$

And

$$\phi_{\mu} \rightarrow \phi_{\mu} - \partial_{\mu} \ln \lambda \quad (2.2).$$

The curvature tensor  $R_{\mu\nu\phi}^{\alpha}$  and  $R_{\mu\lambda}$  are typical invariant for Weyl theory, co-tensor of gauge weight 0.

When Weyl proposed the transformation, he has unification of gravitation and electromagnetism in mind.  $\phi_{\nu}$  serves as electromagnetism potential, and

$F_{\mu\nu} = \frac{\partial \phi_{\mu}}{\partial x^{\nu}} - \frac{\partial \phi_{\nu}}{\partial x^{\mu}}$  is Weyl transformation invariant by definition.

Equation (2.1)  $g_{\mu\nu} \rightarrow \lambda^2 g_{\mu\nu}$  leads to  $ds \rightarrow \lambda ds$ . The change of  $ds$  has far more implication than in gravity.

In special relativity  $ds$  is invariant between different inertial systems and for general relativity,  $ds$  varies at different space time, locally we can define an

inertial *Minkowski* system, but  $ds$  is different for different space time.  $ds$  can be eliminated from the kinematics which  $ds$  is not observables. But in the dynamics,  $ds$  may have implication of the global properties.

In this paper, a scale factor weight (to be different from Weyl gauge weight) is defined based on its relationship with  $ds$ .  $x^\mu$  and  $\frac{\partial}{\partial x^\mu}$  is defined to be zero scale factor weight.

If charge  $q$  has a scale weight zero,  $j^\mu$  shall have scale weight -3 because  $\int \sqrt{g} d^3x j^0 = Q$  ( $\sqrt{g}$  in 3-space has scale weight 3). By the same argument, if mass  $m$  has a scale weight zero,  $T^{\mu\nu}$  has scale weight -3 because  $\int \sqrt{g} d^3x T^{00} = M$ .

From Einstein's field equation:

$$R_{ij} - \frac{1}{2} g_{ij} R = -8\pi G T_{ij}$$

$G$  has scale weight of -1.

Table 1: The scale weight of Common dynamic variables for electromagnetism and gravitation

variable	Scale weight	Variable	Scale weight
$A^\mu$	-1	$p^\mu$	-1
$A_\mu$	+1	$p_\mu$	+1
$g_{\mu\nu}$	+2	$F_{\mu\nu}$	+1
$g^{\mu\nu}$	-2	$F^{\mu\nu}$	-3
$J^\mu$	-3	$T_{\mu\nu}$	+1
$J_\mu$	-1	$T^{\mu\nu}$	-3
$R_{\mu\nu}$	0	R	-2
G	-1	$L_{\mu\nu}$	+1
		$L^{\mu\nu}$	-3

In quantum mechanics,

$$p_\mu \phi = i\hbar \frac{\partial \phi}{\partial x^\mu} \quad (3)$$

To bridge the relationship between quantum mechanics and classic dynamics,  $\hbar$  must have scale weight +1.

In the Schrödinger equation, if  $\phi$  is defined to have a scale weight of +1 just like the gauge theory,  $\phi^*$  has a scale weight of -4 because of the

$$\int \phi^* \phi \sqrt{g} d^3x = 1$$

For the Dirac wave function if  $\psi$  has a scale weight of +1,  $\bar{\psi}$  has a scale weight of -3 because  $J^\mu = \bar{\psi} \gamma^\mu \psi$  has a scale weight of -3. There are other possible definitions of scale factor weight for wave functions. The following is the list of the scale weight of quantum variables.

Table 2: The scale weight of quantum field theory

variable	Scale weight	Variable	Scale weight
$\hbar$	+1	$\phi^*$	-4
$A^\mu$	-1	$\phi$	+1
$A_\mu$	+1	$\gamma_\mu$	+1
$p_\mu$	+1	$\gamma^\mu$	-1
$p^\mu$	-1	Dirac wave function $\psi$	+1
$J^\mu$	-3	$\bar{\psi}$	-3
$J_\mu$	-1	$k_\mu$	0
$T_{ij}$	+2	$k^\mu$	-2

It is clearly that Klein-Gordon equations are not invariant unless  $\lambda$  is constant or  $\lambda$  satisfies a certain relationship. Also, the Lagrangian L for several fields has a scale weight of non-zero. We will do the analysis of the impact of scale invariant requirement on the different field equations.

Due to the assumption that mass and charge have zero scale factor weight, the momentum of a virtual photon  $k_\mu$  has zero weight of scale factor because it is a partial derivative of the  $A_\nu$  in the  $x^\mu$  direction.

Weyl's first introduction of the transformation Eq.(2) is to interpret the  $\phi_\mu$  as electromagnetism in the affine connections. From our scale factor weight analysis,  $\phi_\mu$  has a scale weight of zero based on the definition of affine connection as in Eq.(1) while  $A_\mu$  has a scale weight of 1 from Table 1. Now, most of physicists give up the Weyl's original idea of  $\phi_\mu$  as electromagnetism potential.

Einstein's objection to the Weyl theory is as following: When a vector is transported, the length of a vector would change:

$$dS = S \phi_{\mu} dx^{\mu} \quad (4)$$

Integrating equation (4), we get

$$S = S_0 \exp \int \phi_{\mu} dx^{\mu} \quad (5)$$

Where  $S_0$  is the length a vector would have in the absence of  $\phi_{\mu}$  field. Einstein noted that vector length can be made proportional to the ticking of a clock by transport the vector along a closed curve. If  $\phi_{\mu}$  has different value from point to point, the clock's setting would change more and more with time. The spacing of atomic spectral lines would be depending on their history and be subject to change with unpredictable results. Since the reality is not the case, Einstein declared Weyl's theory to be unphysical.

In this paper, a scale factor is defined like Weyl's proposal. For those variables or equations which cannot be scale invariant by choosing the right scale factor, is not observable in quantum mechanics. There are variables, like the momentum which is not observable. The introduction of scale factor to the physics variables, may explain which variables are not observables and which variables are observable in quantum mechanics.

It is easy to clear up Einstein's objection to Weyl's proposal by requiring that

$$\oint \phi_{\mu} dx^{\mu} = i2\pi n \quad (6)$$

Then eq.(5) would leads to  $S$  invariant. It is easy to derive that a single electron circulates the proton in the time  $t$  with an orbit of Bohr radius (*Ref. 7*). It is easy to derive using the simple Bohr model that

$$\phi_0 = \frac{ie}{\hbar c} A_0 \quad (7)$$

From our scale weight analysis,  $\phi_{\mu}$  has scale weight 0,  $A_{\mu}$  and  $\hbar$  both has scale weight 1. It is acceptable to assign  $\phi_{\mu}$  like Eq.(7) which has scale weight 0.

### 3. Scale factor for scale invariant Maxwell equations

$A_\mu$  has the scale weight of +1, the field variable  $F_{\mu\nu}$  will vary as following:

$$F_{\mu\nu} = \frac{\partial A_\mu}{\partial x^\nu} - \frac{\partial A_\nu}{\partial x^\mu} \implies F_{\mu\nu} = \lambda \left( \frac{\partial A_\mu}{\partial x^\nu} - \frac{\partial A_\nu}{\partial x^\mu} \right) + A_\mu \frac{\partial \lambda}{\partial x^\nu} - \frac{\partial \lambda}{\partial x^\mu} A_\nu \quad (8)$$

Obviously from Eq.(8), besides  $\lambda = \text{constant}$ , if  $\delta\lambda \propto A_\mu dx^\mu$ ,  $F_{\mu\nu}$  will be linear in the scale factor  $\lambda$ .

The scale factor requirement (see (9) of the following) for field variable to be linear in scale factor  $\lambda$

$$\delta\lambda \propto A_\mu dx^\mu \quad (9)$$

is an interesting conclusion because this is same as the Randers's metric and also the same term appears in Eq.(6).

For the Maxwell equation:

$$\partial_\mu F^{\mu\nu} = -J^\nu$$

The formal equation with  $g^{\mu\nu}$  to raise and lower index shall be written as

$$\lambda^{-2} g^{\rho\nu} \partial_\mu (\lambda^{-1} g^{\mu\theta} F_{\theta\rho}) = -\lambda^{-3} J^\nu$$

For the Maxwell equation to be invariant,

$$\partial_\mu (\lambda^{-1} g^{\mu\theta}) = 0 \quad (10)$$

Is needed. Using the Eq.(9), Eq.(10) can be rewritten as:

$$-A_\mu g^{\mu\theta} + \lambda \partial_\mu g^{\mu\theta} = 0$$

One of the choices for  $g^{\mu\nu}$  is:

$$g^{\mu\nu} = \eta^{\mu\nu} e^{\int \frac{A_\delta}{\lambda} dx^\delta} \quad (11)$$

Which will make Maxwell equation become invariant

$$g^{\rho\nu} g^{\mu\theta} \partial_\mu F_{\theta\rho} = -J^\nu$$



The extra term  $e^{\int \frac{A_\delta}{\lambda} dx^\delta}$  embedded in the  $g^{\mu\nu}$  is interesting because its similarity to Eq.(6). We will come back to this term in another paper of exploring the origin of quantum mechanics. Eq.(11) indicates that Maxwell equation is scale invariant in the conformal flat space time, the scale factor defined in this present paper is a conformal factor. If the term  $\int \frac{A_\delta}{\lambda} dx^\delta = i2\pi n$ ,  $g^{\mu\nu}$  is equal to  $\eta^{\mu\nu}$ . From Eq.(6) we see that  $\lambda = \frac{\hbar c}{ie}$ . This complex scale factor makes the assumption of converting the Fourier Transformation to Laplace Transformation reasonable in Quantum Mechanics.

The other part of Maxwell equation is:

$$F_{\mu\nu,p} + F_{\nu\rho,\mu} + F_{\rho\mu,\nu} = 0 \quad (12)$$

Eq.(12) is scale invariant by substitution of

$$F_{\mu\nu} = \lambda \left( \frac{\partial A_\mu}{\partial x^\nu} - \frac{\partial A_\nu}{\partial x^\mu} \right) + A_\mu \frac{\partial \lambda}{\partial x^\nu} - \frac{\partial \lambda}{\partial x^\mu} A_\nu$$

into the above Eq.(12) without assumption of any property of scale factor  $\lambda$ . With the choice of Eq.(10), the Maxwell equation is scale invariant for both parts of the Maxwell equations.

#### 4. Scale factor of scale invariant quantum mechanics variables and Dirac equation

Eq.(3), the definition of quantum momentum, is not invariant because after the scale transformation,

$$p_\mu \phi = -i\hbar \frac{\partial \phi}{\partial x^\mu} - i\hbar \partial_\mu (\ln \lambda) \phi \quad (13)$$

It makes sense that the momentum in quantum mechanics is not observable because  $-i\hbar \partial_\mu (\ln \lambda) \phi$  is zero only when  $\lambda(x, p)$  is *constant* or is a function of momentum only.

If  $\lambda$  is a function of momentum  $\lambda(p)$  only, then  $p^\mu \rightarrow p^\mu \lambda^{-1}(p)$ . The  $\int d^4 p$  becomes  $\int \lambda^{-4}(p) d^4 p$  after the transformation. In the section 8, we will use this re-gauge of the momentum to replace renormalization.

In consideration of the scale weight of  $\hbar$  and  $\phi$ , Klein-Gordon equation is varied as:

$$p^\mu p_\mu \lambda \phi = m^2 \lambda \phi = -\lambda \hbar^2 \frac{\partial(g^{\mu\nu} \frac{\partial \phi}{\partial x^\mu})}{\partial x^\nu} - \lambda \hbar^2 \frac{\partial(g^{\mu\nu} \frac{\partial(\ln \lambda)}{\partial x^\mu} \phi)}{\partial x^\nu} \quad (14)$$

If last term of Eq.(14) is zero, Eq.(14) becomes the standard Klein-Gordon equation

$$(\hbar^2 \partial^\mu \partial_\mu + m^2) \phi = 0$$

Define a vector  $\frac{\partial \ln \lambda}{\partial x^\mu} = \Lambda_\mu$ , the Klein-Gordon equation is invariant if the

$$\partial_\nu (g^{\mu\nu} \phi \Lambda_\mu) = 0 \quad (15)$$

Eq.(15) has a solution of

$$g^{\mu\nu} = \eta^{\mu\nu} \phi^{-1} \quad (15.1)$$

And

$$\lambda = e^{\Lambda_\mu x^\mu} \quad (15.2)$$

where  $\Lambda_\mu$  is only a function of momentum p. Eq.(15) will be re-visited in the future paper regarding the origin of quantum behavior of particles. Eq.(15.2) indicates if  $\Lambda_\mu$  is a constant vector, then  $\lambda$  will make the equation (13) become a Laplace transformation instead of the Fourier transformation.

Schrödinger equation,

$$E\phi = \frac{-\hbar^2 \partial^2 \phi}{2m \partial x^2} + V\phi$$

is scale invariant if  $\partial_i (g^{ij} \Lambda_j) = 0$  where i or j = 1, 2 or 3. Please note that E in Schrödinger equation is scale 0 because E is part of the  $p^\mu p_\mu$ . Obviously, E shall be observable because the Schrödinger equation is invariant with the right choice of scale factor, metric tensor and wave function satisfying  $\partial_i (g^{ij} \Lambda_j) = 0$ . In the relativity theory, the metric tensor is related to measurement of physics quantities, scale factor is a re-gauge of the metric tensor, the study of Eq. (15) may reveal something interesting regarding the quantum behavior from the geometric point of view.

In the current physics, for both Dirac equation and Schrodinger equation:

$$P_\mu \rightarrow P_\mu + eA_\mu$$

With the hope that the transformation of

$$A_\mu \rightarrow A_\mu - \partial_\mu \ln \lambda$$

will give the same dynamic results. But as we know that the success of Aharonov and D. Bohm experiment (*Ref. 8*) indicates that  $A_\mu$  is a dynamic variable in stead of a mathematical object. The scale factor defined in this present paper and the gauge factor can be the same as in the quantum mechanics for the wave function. But in this paper, other variables are also assigned different weight of scale factor. Also,  $\lambda$  can have other choices besides the gauge theory.

For Dirac Equation,

$$(i\gamma^\mu \partial_\mu - m) \psi = 0 \quad (16)$$

If Dirac wave function has the scale weight of +1, the condition for Dirac equation to be scale invariant is:

$$(\gamma^\mu (\partial_\mu \ln \lambda)) \psi = 0 \quad (16.1)$$

Put in the Dirac  $\gamma$ -Matrix, the solution for Dirac equation to be invariant, is that the scale factor must meet the following conditions:

$$(\partial_t \lambda)^2 = (\partial_{\vec{x}} \lambda)^2$$

That means that the scale factor  $\lambda$  satisfies the zero mass Klein-Gordon equations.

The boundary conditions in the quantum mechanics equations determine the value of  $k_\mu$ . If  $\lambda$  is only a function of the momentum, Eq.(16.1) is also automatically satisfied. We see again that the scale factor is a dynamic variable describe the behavior of particles in the momentum space.

## 5. The scale factor for equation of motions

In the classic equation of motion time is used as a parameter, the classic equation of motion will all be invariant under this scale factor transformation because the scale factor is the weight of  $ds$ , the four-dimension distance.

The equation of motion for Lorentz force,

$$m \frac{d^2 x^\mu}{d\tau^2} + F_\nu^\mu \frac{dx^\nu}{d\tau} = 0 \quad (17)$$

After the scale factor for the momentum is introduced, there will be an additional term:

$$m \frac{d^2 x^\mu}{d\tau^2} + F_\nu^\mu \frac{dx^\nu}{d\tau} + m \frac{d \ln \lambda}{d\tau} \frac{dx^\mu}{d\tau} = 0 \quad (18)$$

By changing  $d\tau$  to  $d\tau'$ , the last term can be re-adsorbed to  $d\tau'$  and eq. (18) become eq. (17). The trouble is that if there are different forces, the scale factor transformation invariant cannot all meet at the same time. It is interesting to combine the electromagnetic force and gravitational force to study  $\lambda$  transformation behavior of the equations of motion.

The equation of motion for general relativity,

$$\frac{d^2 x^\mu}{d\tau^2} + \Gamma_{\nu\rho}^\mu \frac{dx^\nu}{d\tau} \frac{dx^\rho}{d\tau} = 0 \quad (19)$$

After the scale factor for the momentum is introduced, there will be an additional term:

$$\frac{d^2 x^\mu}{d\tau^2} + \Gamma_{\nu\rho}^\mu \frac{dx^\nu}{d\tau} \frac{dx^\rho}{d\tau} + \frac{d \ln \lambda}{d\tau} \frac{dx^\mu}{d\tau} = 0 \quad (20)$$

By changing  $d\tau$  to  $d\tau'$ , the last term can be re-adsorbed to  $d\tau'$  and Eq. (20) become Eq.(19). For general relativity, Equation (20) can be written like Equation (19) if

$$\Gamma_{\mu\nu}^\alpha = \left\{ \begin{matrix} \alpha \\ \mu\nu \end{matrix} \right\} + \frac{1}{2} (\delta_\mu^\alpha \Lambda_\nu + \delta_\nu^\alpha \Lambda_\mu) \quad (21)$$

Where  $\Lambda_\nu = \frac{\partial \ln \lambda}{\partial x^\nu}$ .

Even though the equation of motion can be invariant under the scale factor transformation, the scale factor defined in this paper will have impact on value of the physics quantity observed as the scale factor transformed. We will come back to do the analysis of Eq (21) in the Self-Interacting Field theory (SI field theory) to be published later by the author.

## 6. Scale factor for continuity equation

The continuity equation:

$$\partial_\mu J^\mu = 0 \quad (22)$$

The extra term introduced is

$$\partial_\mu J^\mu - 3J^\mu \Lambda_\mu = 0 \quad (22.1)$$

From Eq.(22.1) we see that as long as the gradient of the scale factor is perpendicular to the current, the continuity equation is invariant. If the current is proportional to the 4-energy momentum, and the gradient of the scale factor is also proportion to the 4-energy momentum, the continuity equation is invariant for the 4 energy momentum magnitude is zero, like the zero mass Klein-Gordon equations.

## 7. The scale factor for angular momentum

The classic angular momentum

$$L_{ij} = x_i p_j - x_j p_i \quad (23)$$

is linear in scale factor if weight +1. But there is an extra term for quantum angular momentum,

$$L'_{ij} = \lambda^2 i \hbar (x_i \frac{\partial \phi}{\partial x_j} - x_j \frac{\partial \phi}{\partial x_i}) + \lambda i \hbar (x_i \frac{\partial \lambda}{\partial x_j} - x_j \frac{\partial \lambda}{\partial x_i}) \phi \quad (23.1)$$

After some algebra, in order for the amplitude of the quantum angular momentum to be invariant under the scale factor transformation,

$$\partial_\delta (g^{\mu\nu} \Lambda_\mu \phi) = 0 \quad (23.2)$$

and

$$y^\mu \Lambda_\mu = 0 \quad (23.3)$$

Eq.(23.2) is similar to Eq. (15). For quantum angular momentum to be scale factor invariant, Eq.(23.3) is needed and Eq.(23.3) indicates that  $\Lambda_\mu$  is perpendicular to  $y$ .

In Summary, from section 3 to section 7, we see that all physics equations are partial derivative of space and time. If an energy momentum dependent scale

factor is introduced, all physics equations are invariant under this scale factor transformation of which only depends on energy momentum, not on coordinates.

The current way of introducing the energy momentum dependent scale factor to all physics observables is a more natural way to remove infinities and to describe the emitting patterns of virtual particles. The new quantum physics by introducing this scale factor with Planck type of terms may reveal many insights of elemental particle properties.

### 8. The scale factor of Planck type term to replace the renormalization.

Following the notation of Francis Halzen and Alan D. Martin in Quarks & Leptons: An Introduction Course in Modern Particle Physics (Ref. 9):

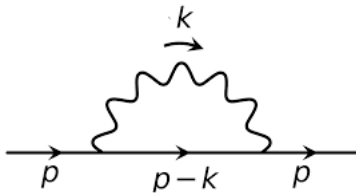

Fig. 1 Electron self-energy

#### 8.1 The mass correction term

$$\delta m = (-ie^2) \int \frac{d^4 k}{(2\pi)^4} \left\{ (\gamma_\nu) \frac{(i\gamma \cdot (p - k) + m)}{-2 p \cdot k + k^2} \frac{1}{k^2} \gamma^\nu \right\} \Big|_{i\gamma \cdot p = -m} \quad (24)$$

The  $k^2$  has scale weight of -2 and  $d^4 k$  has scale weight of -4, thus the  $\delta m$  has the scale weight of -2. But mass has the scale weight of zero.  $\lambda^2$  must be included in the integration into the mass correction  $\delta m$ .

Note that  $\sqrt{g}$  in the momentum space has zero scale factor weight. The green's function of Dirac equation:

$$(i\gamma_\mu \partial^\mu - m)G_F = \delta^4(x - x')$$

Which indicates that  $G_F$  has the scale factor weight of -4. Fourier transformation of green's function to momentum space:

$$G_F(x - x') = \frac{1}{(2\pi)^4} \int S_F(p) e^{-ip \cdot (x - x')} d^4 p$$

Where

$$S_F = \frac{1}{(\gamma_\mu p^\mu - m)}$$

Thus, the momentum space integration has scale factor weight of -4.

Eq.(24) is divergent in large  $k^2$ . Recall that in the blackbody radiation discovery in the early 20<sup>th</sup> century, radiation energy distribution as a function of frequency is divergent in ultraviolet frequency. Planck introduced the quantum behavior of radiation frequency in a cavity to bring the Planck term to the frequency distribution. The introduction of the scale factor of Planck type for the  $\delta m$  will converge the  $\delta m$ .

Assume the virtual particle 4-momentum square  $k^2$  has the role of the frequency of radiation, the parent particle has the role of cavity while the 4-momentum square of the electron  $p^2 = m^2$  as the role of temperature, a Planck term of the following pattern can be introduced to the propagator, and then integration over the virtual particle four-momentum space  $d^4k$  is no longer divergent for  $\delta m$  propagator

$$\lambda^2 = \frac{\frac{k^4}{m^4}}{\left(\frac{k^2}{e m^2} - 1\right)^2} \quad (25)$$

Both the electron and virtual photon can be the radiation role of the “Blackbody radiation”. It is clearly that in large  $k$ , this Planck type term will convergent the  $\delta m$ .

## 8.2 The Vacuum Polarization

In the vacuum, the photon has 4-momentum  $q$  can fluctuate into electron-positron pair which is called the vacuum polarization. The polarization propagator is:

$$iI_{\mu\nu}(q) = -(-ie)^2 \int \frac{d^4p}{(2\pi)^4} \frac{i}{(p+q)^2+m^2+i\epsilon} \frac{i}{p^2+m^2+i\epsilon} \text{Tr}\left(\gamma_\mu(\not{p} + \not{q} + m)\gamma_\nu(\not{p} + m)\right) \quad (26)$$

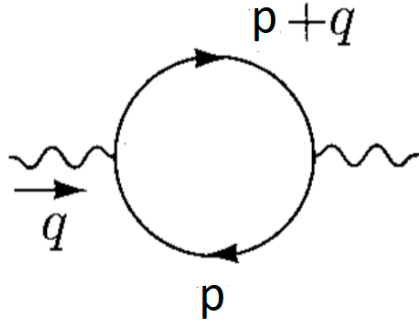

Fig 2. Vacuum Polarization

It is clear that this polarization propagator is divergent to the order of  $p$  square. A Planck type term is needed in to make the Vacuum polarization convergent.

$I_{\mu\nu}(q)$  is supposed to have zero scale factor weight (see *Ref. 9, Page 156*), but the Eq. (26) has scale factor of -2.  $\lambda^2$  is needed to make  $I_{\mu\nu}(q)$  having the correct scale weight. Assume  $q^2$  is like the blackbody temperature parameter  $T$  in the cavity, the electron-positron pair is like the “blackbody radiation”. Only one of the electron-positron pair is the “Blackbody radiation”, the other is the continuation of the virtual photon, a Planck type of scale factor of the following type can be introduced to the propagator:

$$\lambda^2 = \frac{\frac{(p^2+m^2)^2}{q^4}}{\left( e \frac{p^2+m^2}{q^2} - 1 \right)^2} \quad (27)$$

Due to the integration, choose one of the electron-positron 4-momentum as the numeration will not change the integration results. This scale factor  $\lambda^2$  goes to zero when  $q^2$  goes to zero comparing with electron mass even  $p^2$  is zero or large.

Even when  $q^2$  is large, the integration over  $p^2$  is still finite because Eq.(27) will converge due to the denominator will become zero at infinite of  $p^2$ . Detailed calculations of the Vacuum polarization can be very interesting. There are also other choices of  $\lambda^2$  which will reflect the internal property of virtual photons. If photon is on the zero-mass shield ( $q^2=0$ ),  $\lambda^2$  is zero, the propagator integration is zero. This analysis indicates that the real photon, will not cause the vacuum polarization.

### 8.3 The vertex correction term:



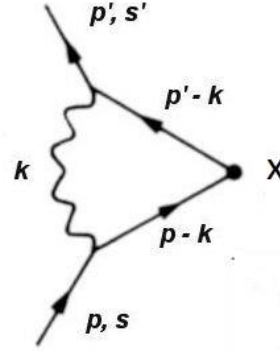

Fig 3. Vertex correction

$$\Lambda_{\mu}(p, p') = (-e)^2 \int \frac{d^4 k}{(2\pi)^4} \left\{ (\gamma_{\nu}) \frac{(-i\gamma \cdot (p-k) + m)}{-2 p \cdot k + k^2} \frac{\gamma_{\mu}}{k^2} \frac{(-i\gamma \cdot (p'-k) + m)}{-2 p' \cdot k + k^2} \gamma^{\nu} \right\} \Big|_{p^2=p'^2=-m^2} \quad (28)$$

The vertex correction term has scale factor of -1. But the vertex correction is

$$\gamma_{\mu} \rightarrow \gamma_{\mu} + \Lambda_{\mu}$$

That means  $\Lambda_{\mu}$  needs to be scale factor weight +1. Thus,  $\lambda^2$  must be included in the integration to make  $\Lambda_{\mu}$  to have equal scale factor weight of  $\gamma_{\mu}$ .

Eq.(28) is divergent at both large and small value of  $k^2$ . In this vertex correction, the electron can emit the virtual photon with momentum  $k$ , like the Eq.(24), and the virtual photon can adsorb the electron and become another electron, like the Eq.(27) of the vacuum polarization. The choice of the scale factor can be as following (the combination of the vacuum polarization and electron-self energy):

$$\lambda^2 = \frac{\frac{k^2}{m^2}}{\frac{k^2}{e m^2} - 1} \frac{\frac{p'^2}{k^2}}{e \frac{p'^2}{k^2} - 1} = \frac{1}{\left( 2 - e \frac{k^2}{m^2} - e \frac{m^2}{k^2} \right)} \quad (29)$$

The beauty of the Planck type term Eq.(29) is that when  $k$  is small, the  $\frac{m^2}{k^2}$  in the denominator will become infinite while  $e \frac{k^2}{m^2}$  is close to 1, when  $k$  is large, the  $\frac{k^2}{m^2}$  in the denominator will become infinite, while  $e \frac{m^2}{k^2}$  becomes 1. The is scale factor  $\lambda^2$  will make the vertex correction term converge for either small  $k$  or large  $k$ .

Since Eq.(25), Eq(27) and Eq(29) are all independent of  $x$ , the coordinate, all the above mentioned scale factor transformation invariant condition is satisfied. This

is the reason the author think that the scale factor is a dynamic variable instead of coordinate variable. It only limits the behavior of the dynamics.

The Planck type term Eq.(25), Eq(27) and Eq(29) will allow the study of all the Feynman diagram corrections to the mass and electric charge possible. By studying the behavior of virtual particles, it will be able to reveal the inside structure of the elemental particles.

## 9. Discussion on quantum mechanics with Laplace Transformation

The scale factor invariant has three kinds of solutions:

The first group of solutions:  $\lambda$  is a constant and can be normalized to 1. This is what the current physics assumes.

The second group of solutions: First order derivative of  $\lambda$  with respect to  $x^\mu$  is zero, or  $\lambda = \lambda(p)$ . This solution is interesting because it may reveal the re-gauge of momentum for the dynamic system. This solution of  $\lambda$  can be used to remove the infinities in QED, QCD and quantum gravitation and to study the sub-structure of elemental particles including virtual photon.

The third group of solutions: Different combination of derivations of  $\lambda$  with metric tensor  $g^{\mu\nu}$  or  $\gamma_\mu$  or other physics variables. Since metric tensor is unique in general relativity, we will come back to this topic in a later paper. These different solutions can be applied to different field of physics to see the implications of the scale invariant transformation.

Recall that the Lorentz transformation and its invariance of physics laws lead to the special relativity and covariance of physics laws. It puts time and space into a coherent and equal footing. The Lorentz transformation put physics law into more elegant format. Another transformation is the gauge transformation of the wave function in quantum mechanics. It links the quantum mechanics to the electromagnetism by requiring the wave function to be phase invariant under the gauge transformation.

When Weyl introduces the gauge transformation of metric tensor, his purpose is to bring the electromagnetic field to the Einstein's field equations. Weyl's metric tensor transformation was before the gauge transformation of wave function.

The scale factor transformation defined in this paper is the extension and re-definition of Weyl transformation to all physics equations. Lorentz transformation and Gauge transformation are space time invariant. This second group solutions of scale factor invariant put the limit on the “radiation” distribution (virtual particles) which may reflect the sub-structure of the dynamics of the “Cavity” (elemental particles).

The quantum mechanics operator is from the definition:

$$p_\mu \phi = -i\hbar \frac{\partial \phi}{\partial x^\mu}$$

If the scale transformation is introduced, and it is only a function of momentum,

$$p_\mu \phi = -i\hbar_0 \lambda(p) \frac{\partial \phi}{\partial x^\mu} \quad (30)$$

Where  $\hbar_0$  is the Planck Constant. The wave function can be found through a re-gauged momentum space Fourier Transformation or Laplace transformation.

If

$$\frac{1}{\lambda(p)} = 1 - i\hbar_0 f(p), \quad (31)$$

wave function of Eq.(30) can be write as:

$$\phi = e^{\frac{i}{\hbar_0}(p_\mu x^\mu + f(p)p_\mu x^\mu)} = e^{\frac{i}{\hbar_0}(p_\mu x^\mu) + \sigma_\mu x^\mu}$$

which is Laplace transformation with  $s_\mu = \frac{i}{\hbar_0} p_\mu + f(p)p_\mu = \frac{i}{\hbar_0} p_\mu + \sigma_\mu$ .

From last a few sections' analysis, the physics variables can be re-gauged by a scale factor in momentum space during the Fourier transformation so that  $\frac{\partial \ln \lambda}{\partial x^\nu} = 0$ . The scale factor invariant in physics leads to the conclusion that all variables is limited in momentum space. Quantum mechanics shall be studied under Laplace transformation. The value or magnitude of  $s_\mu$  describes the momentum distribution of the emitting virtual particles.

The final form of scale factor needs to be determined by experiments. For the electron self-energy and vacuum polarization, the scale factor can also take the format like the Eq.(29) for the emission and adsorption with the different  $\lambda(p)$  and  $\lambda'(p)$ . In the Vertex Correction, the adsorption of the virtual photon can be

by different electrons. Due to the space time scale may be different for virtual particles from the inverse Laplace Transformation, there may be many different energy-momentum virtual particles are being transferred in our space-time scale:

Given the Laplace transform  $X(s)$ , the original space-time can be obtained by the inverse Laplace transform, which can be derived from the corresponding Fourier transformation with a new scale of space-time. We first express the Laplace transform as a Fourier transform:

$$L[f(x^\mu)] = X(s) = X\left(\frac{i}{\hbar_0} p_\mu + \sigma_\mu\right) \\ = \int_{-\infty}^{\infty} f(x^\mu) e^{\frac{i}{\hbar_0}(p_\mu x^\mu) + \sigma_\mu x^\mu} d^4 x^\mu = F(f(x^\mu) e^{\sigma_\mu x^\mu}) \quad (31)$$

If  $f(x^\mu) = x^\mu$ , the space time is regauged by a factor of  $e^{\sigma_\mu x^\mu}$ . If  $e^{\sigma_\mu x^\mu}$  is small, like  $10^{-5}$ , the time will be much smaller than our time. The virtual particles can be travelling in a re-Gauged space time like in the Figure 4 which two or many more equal virtual photons are exchanged but travelling in a much smaller time scale. Is this the quantum entanglement state? We will discuss this in another paper: The Origin of Quantum Mechanics and the sub-structure of elemental particles.

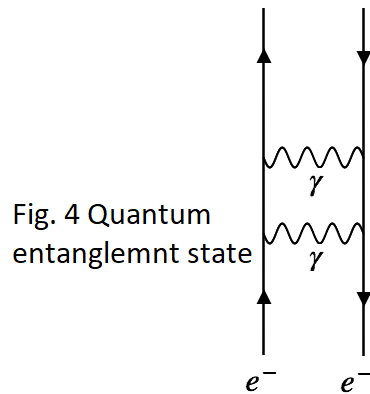

Instead of inventing many schemes to avoid infinities in the perturbation theory of QED and QCD, physicist shall focus on finding the experimental data to compare with the Laplace transformation in order to determine the  $s_\mu$ . By studying the scale factor in the momentum space (or  $s_\mu$  of the Laplace transformation), the virtual particle emitting behaviors will be revealed which shall in turn indicate the internal structure of the elemental particles. In the future paper regarding

the origin of quantum mechanics, the virtual particle behavior will be studied to derive the quantum assumptions.

The scale factor invariant of physics can also be defined as different constants (or the global scale) of the physics law. Dirac's large number principle connects the distance scale of the universe to the scale of the nuclei, the time scale of the universe to the time scale of strong interaction. In the continuation of the CCSI field theory and the origin of quantum mechanics theory, the scale factor will be re-visited through the different physics constants.

## References:

1. Sakurai, J.J.: *Advanced Quantum Mechanics* Pearson Education, Incorporated, (1967)
2. Feynman, Richard P.; Morinigo, Fernando B.; Wagner, William G. (1995). *Feynman Lectures on Gravitation*. Reading, Mass.: Addison-Wesley. ISBN 978-0201627343. OCLC 32509962.
3. Hamber, H. W. (2009). *Quantum Gravitation – The Feynman Path Integral Approach*. Springer Nature. ISBN 978-3-540-85292-6.
4. *Smolin, Lee (2006). The Trouble with Physics: The Rise of String Theory, the Fall of a Science, and What Comes Next. New York: Houghton Mifflin Co. ISBN 978-0-618-55105-7.*
5. *P. A. M. Dirac (1974). "Cosmological Models and the Large Numbers Hypothesis". Proceedings of the Royal Society of London A. 338 (1615): 439–446.*
6. *A. Eddington (1931). "Preliminary Note on the Masses of the Electron, the Proton, and the Universe". Proceedings of the Cambridge Philosophical Society. 27 (1): 15–19.*
7. The papers written by William O. Straub in the website is very interesting for Weyl theory. <http://www.weylmann.com/weyltheory.pdf>
8. Y. Aharonov and D. Bohm, Phys. Rev. 115, 485 (1959).
9. Halzen, Martin: *Quarks and Leptons*; Wiley (1984)