

Zero Quantum Gravity

Stephen H. Jarvis 

Xemdir, web: www.xemdir.com

email: stephen.jarvis@xemdir.com

Abstract: Proposed here is a new approach to the known disparity between the 4d spacetime designs of quantum field theory (QFT) and general relativity (GR). The reason for calculus in physics, and how and why QFT developed as flat 4d spacetime and GR as curved 4d spacetime shall be outlined. The key difference between QFT and GR in the context of the GR based Λ CDM model shall be confirmed as the condition of QFT requiring independent inertial frames of reference and GR requiring dependent inertial frames of reference. Following such, a brief account of current attempts uniting QFT and GR as the search for quantum gravity shall be outlined. In making use of the known QFT and GR data, their flat/curved 4d spacetime disparity, and the difficulty in proving quantum gravity, a new approach forward is proposed via a zero-dimensional number theory application to physical data. By this zero-dimensional number theory, the QFT and GR data and associated flat/curved spacetime disparity are confirmed, together with presenting a zero-dimensional quantum gravity paradigm termed as "zero quantum gravity" outlining QFT processes that prescribe a proposed zero-point gravitational field effect that can be tested experimentally. Here, the intention is not to disrupt or dispel the current quests for quantum gravity, yet to offer a current theoretic and experimental utility to the known mismatch between QFT and GR on that path to quantum gravity.

Keywords: golden ratio; calculus; infinitesimal; quantum field theory; general relativity; quantum gravity; temporal mechanics; zero-dimension; information paradox; Λ CDM; Clay Mathematics Institute; Xemdir

1. Introduction

Here the work of Temporal Mechanics¹² and associated zero-dimensional number theory discusses the fundamental importance of calculus in physics and how such has led to not just the Λ CDM³ model, yet how the dimensional number theory mismatch between quantum field theory⁴ (QFT) and general relativity⁵ (GR) has occurred, and beyond such how this mismatch can be made use of. The purpose of this historical and contemporary exploration is not to question if physics is fundamentally misdirected, *yet to support how and why physics describes reality the way it does and then suggest a logical next step.*

Of course, this type of task is performed daily by schools, universities, learning institutions, and forums the world over in the form of question and answer on this very subject. For, when physics is taught, questions are being asked by students, answers are discussed, and new approaches debated, and the status quo usually maintained if not for a new step of theory that presents with new proof. Here this task will be presented in the following manner:

1. Introduction
2. State of the art
3. Infinitesimal logic
4. Dimensional Calculus
5. Flat and curved 4d spacetime
6. Zero-dimensional number theory
7. Zero-dimensional holographic universe
8. The zero-point gravitational field (Xemdir)
9. The zero-point gravitational field (Xemdir) thruster
10. Zero-dimensional number theory: overview
11. Conclusion

The unique approach executed here is in taking a closer look at the upside of the mismatch between QFT (*flat* 4d spacetime) and GR (*curved* 4d spacetime) with a new bridging zero-dimensional number theory. Here, the upside of the mismatch between QFT and GR is proposed to be an entirely new theoretic zero-dimensional number theory script.

The key finding of this zero-dimensional number theory, when scaled to physical phenomena, is there being a zero-point gravity field effect in play derived to be responsible for time's arrow and entropy.

¹The current work of 56 papers detailing a new mathematical approach to the dimensions of time and space as zero-dimensional logic, see <https://www.xemdir.com/>.

²[1][2][3][4][5][6][7][8][9][10][11][12][13][14][15][16][17][18][19][20][21][22][23][24][25][26][27][28][29][30][31][32][33][34][35][36][37][38][39][40][41][42][43][44][45][46][47][48][49][50][51][52][53][54][55][56].

³ The cold dark energy (Λ) and cold dark matter (CDM) cosmological model [57].

⁴ A theoretical framework combining classical field theory, special relativity, and quantum mechanics [58][59].

⁵ Einstein's theory of general relativity [60][61].

To thoroughly present that case and how such can be tested, an analysis of the differences between the dimensional number theories of EM as quantum field theory (QFT) and gravity as general relativity (GR) needs to be presented to ensure all relevant professional readership is being acknowledged and addressed in this new proposal.

2. State of the art

The state of the art in physics circa 2023 circumscribes a dedication to dimensional number theory, indeed as a variety of geometric calculus methods presenting the case for two key physical theory pillars, namely QFT and GR. The dimensional number theories for QFT and GR do in fact not link, and hence the quest to rectify that mismatch with a bridging dimensional/hyperdimensional number theory model. An example of this quest is evident with the Clay Mathematics Institute (CMI) Millennium Prize Problems⁶ and those number theory pursuits as described in papers 44 [44], 49 [49], and 55 [55] of Temporal Mechanics.

Calculus wizardry on its own though is not sufficient as a basis for a physics theory, as any dimensional number theory needs to be relevant to and directly point to known observable data. Universities and research agencies and their associated data agree with the current number and associated physical theories describing that data, leading to the current QFT and GR models for EM and gravity respectively. Such is a clear advancement of how numbers and geometry were thought to apply to physical reality early in science's history.

Indeed, to present a new model based on a few bits of data is not what physics is looking for, and such is not the process here. Here in this paper, the widely published and accepted physics theories⁷ of QFT and GR are examined, while then proposing a way to make use of the flat and curved 4d spacetime mismatch between QFT and GR respectively. Specifically, here in this paper and its references to the work of Temporal Mechanics is an account of calculus as a descriptive application for physical phenomena, namely how calculus came to be, how it was applied to physical phenomena, and how it has grown as two particular dimensional number and thence physical theories into the infrastructures of QFT and GR. Essentially, this paper will look at the structuration of calculus found in QFT and GR and determine if any benefit can be granted from the known difference between flat and curved 4d spacetime.

The inspiration for this paper has come from a recent⁸ inquiry into the nature of zero-dimensional time and zero-dimensional space, an almost seemingly counter-intuitive if not entirely abstract approach

⁶ "To celebrate mathematics in the new millennium, the Clay Mathematics Institute of Cambridge, Massachusetts (CMI) established seven Prize Problems. The Prizes were conceived to record some of the most difficult problems with which mathematicians were grappling at the turn of the second millennium; to elevate in the consciousness of the general public the fact that in mathematics, the frontier is still open and abounds in important unsolved problems; to emphasize the importance of working towards a solution of the deepest, most difficult problems; and to recognize achievement in mathematics of historical magnitude" [62].

⁷ And associated proofs/data qualified by the widely practiced journal-submission approach [63].

⁸ Circa 2017.

to studying physicality. This inquiry has been described in volumes 1-8 of Temporal Mechanics⁹, consisting of 56 papers [1-56]. Unlike popular science fiction¹⁰, the work of Temporal Mechanics is not in the regard of aiming to make time machines in seeking to break the known arrow of time, yet examining the deeper structure to the arrow of time itself without corrupting the known entropic direction of that arrow. There, the idea of examining how a number theory can evolve from a certain approach to defining a point in space and moment in time is chartered. To achieve such, all that physics understands of dimensional and thence physical analysis must be first considered.

3. Infinitesimal logic

Questioning reality has always been a part of human social development, from ancient times to today. Many of the great questions of reality and human achievements have come in the form of paradoxes, or rather, puzzles that present challenges for not just the physical human achievement yet human thought. Some of these ancient puzzles have come in the form of Zeno's paradoxes¹¹, as a method of proof called *reductio ad absurdum*¹². One such puzzle is the Dichotomy argument, namely:

That which is in locomotion must arrive at the half-way stage before it arrives at the goal.
— as recounted by Aristotle, *Physics* VI:9, 239b10 [70]

Figure 1

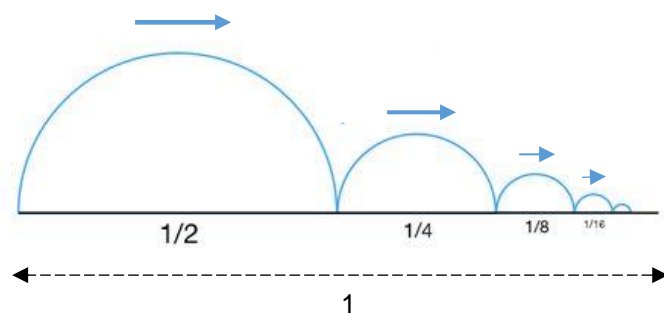

Here, in aiming to achieve “1”, one must quest to complete an infinite number of tasks, and thence by such be *forever unable* to achieve the “1” result given the considered endlessness of infinity. The puzzle is termed a “dichotomy” owing to the constant splitting process involved in each step of the task in highlighting to its core the idea of both fractions and approaching the idea of an infinitely small length. Simply, what makes this puzzle impossible is that the overall aimed length of completion as “1” divided

⁹ The work of Temporal Mechanics is not involved in the construction of theoretical time machines yet examining the deeper structure to the arrow of time itself without corrupting the direction of that known arrow.

¹⁰ The promoted idea of time travel, whether into the past or into the future [64].

¹¹ As based on based on Plato's *Parmenides* (128a–d) [71].

¹² Also known as *proof by contradiction*.

by an infinite number of steps leads to $\frac{1}{\infty}$ which of course approaches the value of 0, and thus an *impossible event* in aiming to reach “1”.

By such debates and puzzles a system of arguments and counter-arguments were formed as the basis for what was to then become a basis for mathematical logic and the analysis of physical reality. There, as has become evident today, *describing* physical phenomena “*conjectures how*” to label physical phenomena, namely:

- (i) what aspects of phenomena are being labelled?
- (ii) with what precision?
- (iii) to what extent, namely how broad and wide (0 to ∞)?

Accompanying such is realizing our own limitation of being conscious, namely:

- (iv) our resolution/pixilation of quantum (light) perception.
- (v) such (iv) in primarily occupying the datum reference of time-now in 3d space.
- (vi) such (v), in the context of a singular dimension (1d) of time’s flow.
- (vii) such (vi) in the context of what can be trusted to be physical laws as a consistent feature of physical reality and our consistent observation ability in it anywhere, anytime.

As is generally agreed, our conscious experience of reality can be considered involving two basic features, two dimensional paradigms, that of the dimension of time¹³, and that of the dimensions of space¹⁴, all of such though as reality in a datum-reference of time-now, one time-now moment to the next, all of such in 3d space.

It would be natural for us to consider that the one dimension of time (1d) and the three dimensions of space (3d) are connected as four dimensional spacetime (4d). Thus, as much as we perceive reality in a type of continuous fashion in the datum reference of time-now, we would consider that reality also operates as a type of 3d space and 1d time continuum as 4d spacetime. Such is what physics proposes as 4d spacetime as a grand platform we would exist with/within¹⁵. We then with such a basis ask how physical reality performs as 4d spacetime. In fact, we test the theories we have of 4d spacetime to see if they measure up with observable physical reality. Further to this, we assess how the description of 4d spacetime can represent the general platform for the description of all other phenomena. By such, as all the data suggests, two versions of spacetime have become apparent, flat 4d spacetime for QFT and curved 4d spacetime for GR.

Of note in this process is that no dimensional number theory has been able to link flat and curved spacetime, or rather there is no dimensional number theory describing the physical phenomenal link between flat and curved spacetime, Thus, mass is still the great mystery of description ordaining the

¹³ 1d, as a type of arrow.

¹⁴ 3d, namely spatial volume.

¹⁵ As a dimensional mathematic model and associated physical theory.

requirement¹⁶ of flat and curved 4d spacetime questing a mass-based number theory link between flat and curved 4d spacetime. How did we get there though, how did we construct the descriptions for curved and flat 4d spacetime?

4. Dimensional calculus

The process here is to appreciate how numbers and geometry relate with the idea of dimensionality via an analysis of mass, namely by recognizing:

- (viii) features of dimensionality, precisely their known parameters and limitations, specifically how *points in space* and *moments in time* (time-now) are captured, such as the idea of:
 - a. an *infinitesimal* datum reference for time-now.
 - b. *infinitesimal* points in space in time-now's *infinitesimal* datum-reference.
- (ix) how approaching the idea of time-now and a point in space requires a particular type of mathematical approach prescribed by *infinitesimal calculus*¹⁷.
- (x) how that calculus (ix) is constructed in adapting to¹⁸ the varying features of physical reality.
- (xi) how that calculus (ix)-(x) acknowledges the idea of a type of symmetry of laws¹⁹ for each infinitesimal point in space and associated infinitesimal moment in time²⁰.

In all, the clear idea here for describing physical processes is assuming the ideas of:

- (xii) a datum reference of time needing to approach an infinitesimal moment of time-now.
- (xiii) 3d space needing to approach infinitesimal points as chosen datum references for infinitesimal moments of time-now.

The word *calculus* comes from Latin meaning "small stone", an apt name given calculus is the art of looking at exceedingly small scale on a broad scale whereby:

- (xiv) *differential calculus* is the mathematical art of cutting something into small pieces to find how that something being cut changes in that cutting process, being useful for:
 - a. instantaneous rates of change.

¹⁶ By current theoretic and measurement standards.

¹⁷ Gottfried Wilhelm Leibniz and Sir Isaac Newton are both given credit for independently inventing and developing calculus, Newton being regarded as the first to apply calculus to physics [65].

¹⁸ Not to be forgotten.

¹⁹ See section 4.

²⁰ See points (xxiv)-(xxvi) ahead.

- b. slopes of curves.
- (xv) *integral calculus* joins (integrates) the small pieces together to find how much there is by that integration process, being useful for:
 - a. accumulation of quantities.
 - b. areas between or under curves.
- (xvi) *differential calculus* and *integral calculus* are therefore *inverse* processes²¹.

Yet **why** must mathematics be used in dimensional analysis to “approach” the idea of a moment in time and point in space? Why not just present a mathematical theory describing zero-dimensional time and zero-dimensional space, as what Temporal Mechanics proposes?

Physics is central to *dimensionality*, namely what is measurable, and so dimensional lengths of space and time are essential. Even if infinitesimally small *points* in space and *moments* in time are required for those actual measurements to take place, dimensionality is required.

Technically, nothing can be measured using a zero-point for time and space as an axiom. A number theory at best can be the only result from a zero-dimensional appraisal of time and space, a number theory which thence must derive dimensionality and thence apply itself to known scales for time and space to then be relevant to physical phenomena and known associated equation descriptors. To achieve that description, a spatiotemporal geometric and thence dimensional number theory is required, namely as one proposing to describe the dimensions of space and time, as a 3d space and 1d time mathematical model, ideally as a unified 4d spacetime using infinitesimal calculus, such as what QFT and GR have achieved.

The initial question for infinitesimal calculus in starting with the dimensions of time and space is how indeed is space related to time, namely how does space demonstrate the feature of time if not for using a concept associated to space and time such as mass, mass as an extension of space, mass as relative motion in time between masses and how mass moves in regard to space, and thence mass as a basic core descriptor of 4d spacetime. This is no coincidence, as mass yet more pertinently *momentum*²² is used as the focus of how physical processes change in space:

- (xvii) how mass changes location in space.
- (xviii) how light as a wave/particle changes location in space:
 - a. as a non-mass wave/particle with momentum,
 - b. has a fixed speed of travel in space,
 - c. and why indeed the speed of light is fixed at c for any inertial frame of reference²³.

²¹ Considered as the *fundamental theorem of calculus*, describing the proposed convergence of infinite sequences and series to defined limits.

²² See point (xxiii) ahead.

²³ See points (xxvii)-(xxviii) ahead.

In short, momentum is used to highlight the idea of motion and thus time regarding space as the subject of mass, and therefore ultimately how mass and light, light as a proxy for mass, move in space using 4d spacetime.

Therefore, 4d spacetime has become the basic emphasis description for not just how light travels in space and thus a description of EM, yet also the movement of mass and how mass relates to mass in space and thence useful as a description for gravity. The issue there though are the two types of 4d spacetime, namely flat and curved for QFT and GR respectively, not being mathematically compatible.

5. Flat and curved 4d spacetime

As described, modern calculus is purpose built for using infinitesimal structures describing physical phenomena mathematically, namely in being as precise (infinitesimal) as possible, creating nonetheless what are termed *infinitesimal estimates*. Having developed a set of tools for describing infinitesimal calculus, integral and differential calculus of course need to be applied to the conditions specific to physical reality, to the dimensions of space and time, and thus must abide by what is physically observed as those specific conditions of nature²⁴ under examination. Yet as presented in points (xvii)-(xviii), the key basis used by physics to describe the dimensions of space and time is *momentum*. There, to make calculus sensible to the dimensions, five basic ideas are used for momentum:

- (xix) *distance* as length of 1 dimensional space.
- (xx) *time* as duration of 1 dimensional time.
- (xxi) *mass*:
 - a. Considered as the intrinsic property of a body.
 - b. Experimentally defined as a measure of the body's inertia.
 - c. Determining the strength of its gravitational attraction to other bodies.
 - d. Proposing inertial and gravitational mass to be identical as per the equivalence principle, such as an *a priori* of GR.
- (xxii) *velocity* of mass as *distance per time*.
- (xxiii) such (xxi)-(xxii) arriving at the basic idea of *momentum* (p ; $kgms^{-1}$), namely the product of the mass and velocity of an object.

According to Sir Isaac Newton's *Philosophiæ Naturalis Principia Mathematica* as a feature of his proposal for inertia²⁵, the rate of change of a body's momentum is equal to the net force acting on it. To

²⁴ Here, the temptation is to think calculus can explain physical reality *primarily* without conditions, yet the fundamental condition of physical reality, what is and what is not, requires calculus in its various forms of construct to adapt to that data.

²⁵ "The vis insita, or innate force of matter, is a power of resisting by which every body, as much as in it lies, endeavours to preserve its present state, whether it be of rest or of moving uniformly forward in a straight line" [66][67].

note with QFT is that even though light has no mass it is still considered a particle with momentum²⁶. Specifically, momentum is proposed to depend on a frame of reference such that in any inertial frame of reference momentum is a *conserved* quantity. Such a process is required for the following reasons:

- (xxiv) *arbitrating* a closed system not affected by external forces such that in that frame of reference the total linear momentum of mass under examination does not change and can thence be described with calculus.
- (xxv) to confirm the required condition of being complete with the calculus analysis process, of not leaving this process of examination and determination to anything else.
- (xxvi) such (xxiv)-(xxv) as a way of making momentum *statutory* for the process of calculus.

The next step in arbitrating these statutory frames of reference is how one frame of reference can relate to another frame of reference, namely that there needs to exist a *universal governance* between frames of reference upon space for objects. Physics terms this as the “*symmetry of laws*”, namely that the set of laws in *frame of reference A* must be the same set of laws for *frame of reference B*. In short, the idea of universal symmetry of laws between different frames of reference is underwritten in the principle of relativity, namely the *requirement that the equations describing the laws of physics have the same form in all admissible frames of reference*.

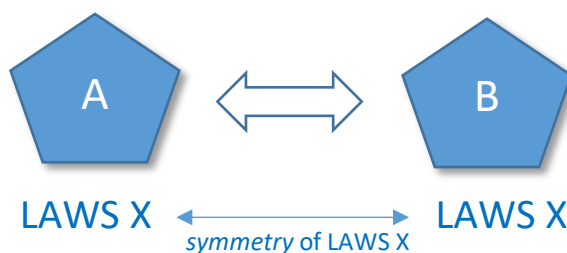

Figure 2: *frame of reference A* having the same laws in play (as LAWS X) as *frame of reference B*.

The required structuration here is extending the calculus of one frame of reference to another frame of reference²⁷. Does for instance the calculus of a process of physical phenomena²⁸ in one frame of reference apply to **any** type of process of physical phenomena for another frame of reference? Can indeed processes of physical phenomena under investigation *be the same fundamental stuff* to allow for a universal calculus to develop between all frames of reference *for all types of objects in space for all types of processes of physical phenomena*?

²⁶ As shown by mathematical deduction based on light being proposed to have kinetic energy and thence momentum.

²⁷ A process named practically as *translational symmetry*.

²⁸ Such as mass or light.

It so happens²⁹ that light and mass have specific conditions for their translational symmetries that require different and specific calculus mapping processes³⁰. Such has resulted in the employment of flat 4d spacetime mapping for QFT and curved 4d spacetime mapping for mass (gravity). Fundamental there are the two physical constraints as postulates proposed by Einstein in adapting to known physical data³¹:

- (xxvii) the laws of physics are invariant³² in all inertial systems³³.
- (xxviii) the speed of light in vacuum c is the same for all inertial observers, regardless of the motion of the light source³⁴.

The proposed if not required result of combining these postulates is the join between space and time, as 4d spacetime. Henceforth, a variety of methods of calculus have been required to describe the nature of light, primarily the natures of the electron and light, all of which have been consistently tested and refined to reach the level they are now at, namely QFT as a flat 4d spacetime model and GR as a curved 4d spacetime model, noting they are still just models and not reality *per se*.

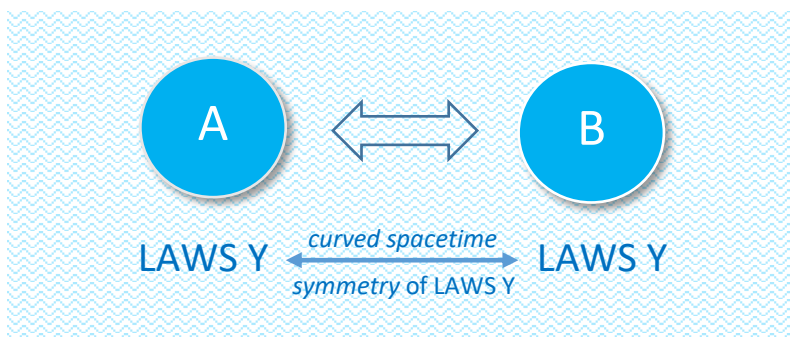

Figure 3: frame of reference A having the same laws in play (LAWS Y, as curved spacetime) as frame of reference B.

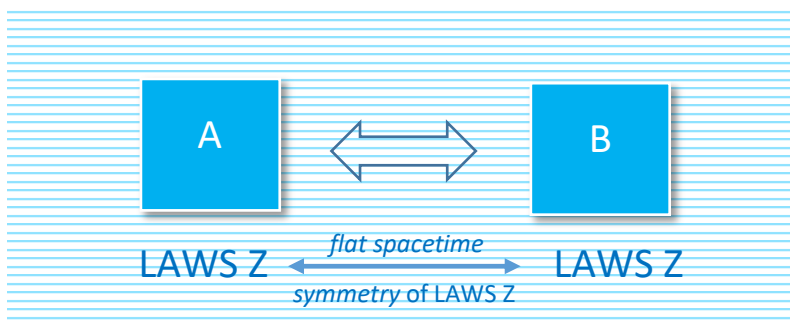

Figure 4: frame of reference A having the same laws in play (LAWS Z, as flat spacetime) as frame of reference B.

²⁹ According to all known measurements of physical phenomena.

³⁰ As per the development of 3d space and 1d time mathematics described initially by Galilean transformations to thence Lorentz transformations forming the basis of QFT's flat spacetime, and thence Minkowski flat 4d spacetime and associated Riemannian geometry adapted by Einstein in his formulation of GR.

³¹ Not to be overlooked.

³² *Identical*.

³³ *Non-accelerating frames of reference*.

³⁴ An experimentally known *requirement*.

Of note regarding the disparity between the *flat* 4d spacetime and *curved* 4d spacetime models is how a 4d spacetime interval is classified as being either dependent³⁵ or independent³⁶ of the inertial frame of reference. There, with GR the 4d spacetime interval between inertial frames of reference is derived to be *dependent* and not independent of inertial frames. This was so to allow for gravitational free fall, specifically *curvature* as the proposed only process available for the infinitesimal calculus of 4d spacetime to accommodate for gravitational freefall. Simply, with GR the 4d spacetime interval between inertial frames of reference is *dependent* and not *independent* of inertial frames. Yet with QFT the 4d spacetime interval is *independent* of the inertial frame of reference (xxvii).

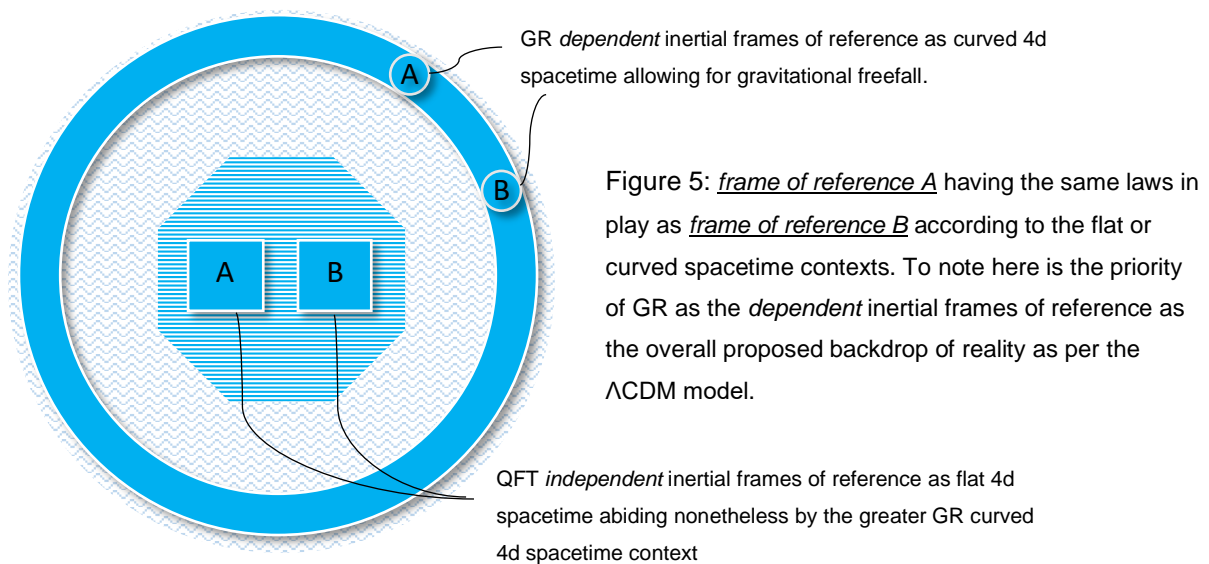

Thus, the disparity between QFT and GR was cast regarding the dependence (GR) and independence (QFT) of the inertial frames of reference. Such is entirely intuitive in considering that as EM technically has no actual mass it could only be expressed as an inertial frame of reference *independently from* its general overall system mass-inertia context-source³⁷, relegating EM to flat 4d spacetime³⁸. Of note in this entire process of describing EM and gravity is the mathematical geometry describing these certain aspects of physical reality, dimensional number theories that can only merely be tools in, as all data has demonstrated, flat and curved spacetime not being truly homogeneous with each other³⁹.

³⁵ *Inclusive.*

³⁶ *Non-inclusive.*

³⁷ Curved spacetime.

³⁸ Thence making flat spacetime secondary to curved spacetime.

³⁹ The quest though is on to find the homogeneity between flat and curved spacetime.

Experimentally, given the eminence of QFT describing the microscopic world of particles at our fingertips⁴⁰, the current quest in physics is to somehow quantize gravity if not making the process of GR compatible with QFT, and thus somehow forging a basis or feature of GR being like QFT such that as the rules of curved spacetime are proposed to breakdown for GR in that process then GR can thence be described in terms of having *independent* inertial frame of reference features on the microscopic scale. Consider figure 6.

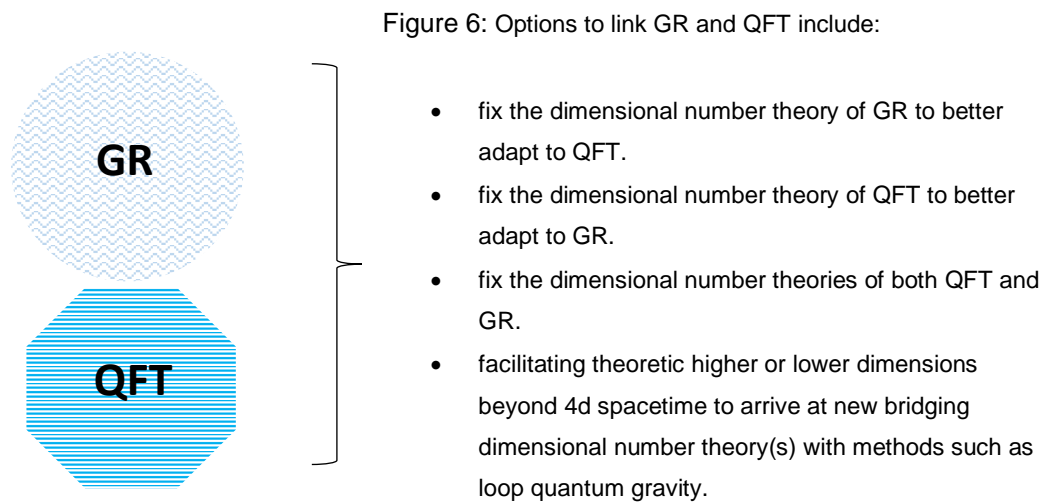

To note is that currently there is *no mathematical way to link GR and QFT*, an impossible task given that such would need to represent an absolute dimensional number theory description of physical reality, a task not possible for the *infinitesimal estimates* approach.

Nonetheless, *in going beyond the 4d spacetime number and physical theory approach*, key proposed solutions include creating hyperdimensional spacetime bridges between QFT and GR⁴¹. In fact, many approaches have been considered, from debating the validity of the calculus of QFT and that of GR, attempting to find flaws in each, to then proposing corrections for QFT and GR to unite the two, to the idea of creating extra dimensional and lower dimensional bridges between flat and curved 4d spacetime. There, some theories propose approaches such as *loop quantum gravity* where the quantum-compatible loop states and associated spatial spin networks “weave-up” physical space with a proposed Planck scale spatial granular structure. All such pursuits though ultimately ask if space can be quantized on the Planck scale and thus can demonstrate quantum features such as entanglement, hence the term for the quest as *quantum gravity* [68][69].

Throughout all the innovative design proposals and processes is of course the need to consider that physical reality and associated phenomena dictates what is real, and not primarily by how numbers are applied to physical phenomena. The temptation therefore is to consider new mathematical modelling

⁴⁰ As compared to the GR cosmological scale of stars.

⁴¹ As a type of *proxy-independency*.

for QFT and GR without considering the need to abide what physical reality requires for the application of numbers to describe physical reality.

As has been thoroughly explored and experimentally demonstrated, QFT requires *flat* spacetime modelling approach and GR *curved* spacetime modelling. The only mathematical number theory that could describe reality *de novo* would be exactly that, namely *de novo*, and thus a zero-dimensional basis. Yet the beauty of the dichotomy of flat 4d spacetime and curved 4d spacetime is that it just makes sense on a most basic level, lines as the shortest distances imaginable, and curves as the larger stretched/curved distances to allow for the option of gravitational free fall. Consider figure 7.

Figure 7

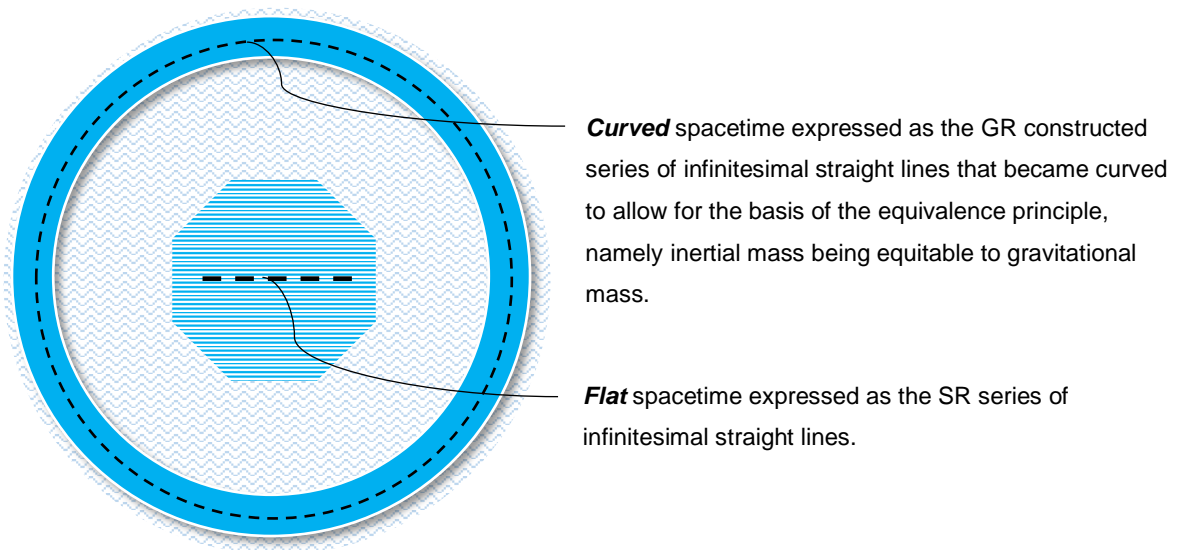

By all of such though, the search is on to somehow find a mathematical formalism that can join flat and curved 4d spacetime, to thence with that new mathematical formalism utilize the benefits of that proposed dimensional link. This has been the case with the CMI Millennium prize problems. Consider figure 8.

Figure 8

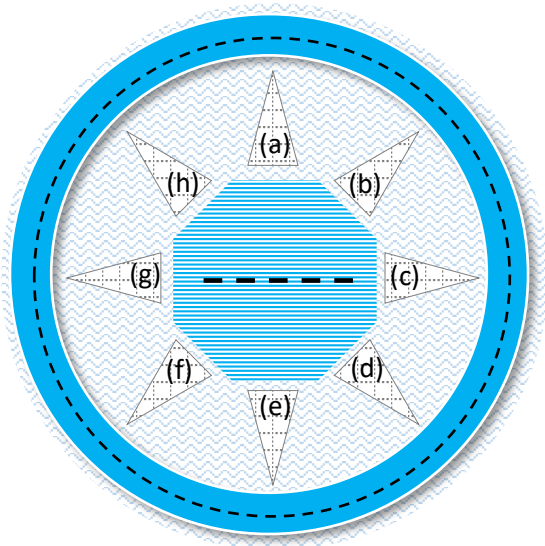

A representation of the quest to link curved (GR) and flat (QFT) 4d spacetime, here illustrated as specific quests/tasks of resolution identified by the CMI as the following problems: Poincare conjecture (a), Hodge conjecture (b), Riemann hypothesis (c), Birch and Swinnerton-Dyer conjecture (d), Yang-Mills existence and mass gap (e), Navier-Stokes existence and smoothness (f), and P versus NP (g). Also included here is Fermat's conjecture (h).

To note is that (a)-(h) are figured and scripted in the context of set theory, such to determine the nature of numbers associated to spatial geometry as those values approach ∞ and if the associated proposed geometries of space and time can change in approaching certain values to describe curved spacetime *emerging* from flat spacetime. Key quests there include the Hodge conjecture (b) which itself relies on the Poincare conjecture (a), both which should then, in each forming a solution for an infinite set, solve the Riemann hypothesis (c), all of which should thence solve the Birch and Swinnerton-Dyer conjecture (d). Solving those problems should then relate solutions to the Yang-Mills existence and mass gap (e), Navier-Stokes existence and smoothness (f), and P versus NP (g) physics problems⁴² as presented throughout paper 55 [55].

By all of such, the current quest in physics is finding how to unite QFT with GR, to somehow merge flat 4d spacetime⁴³ with curved 4d spacetime⁴⁴. All of such are well-reasoned pursuits, yet ultimately the physical nature of reality needs to confirm any such modelling, a proposed *singularity* realm where the rules of standard physics are proposed to break down. Do these rules break down though in all physical fact?

The problem with exploring the *singularity* level is that the calculus of both QFT and GR breaks down when the quantum and gravitational fields break down, so an entirely new calculus is required to account for any absolute zero-dimensional states for time and space in measuring and predicting the phenomena of such a process in physical reality. Otherwise, the problem is how to demonstrate the singularity process in a laboratory showing any potential link between QFT and GR as those spacetime fields are proposed to break down. By such, the research proposals there are central to finding

⁴² All of such described in paper 55 [55].

⁴³ Forming the core of QFT.

⁴⁴ Forming the core of GR.

phenomena at the *cusp* of such an event horizon, such a singularity, and thence with current proposals how space on a Planck scale can somehow demonstrate quantum mechanical features intrinsic to QFT such as quantum entanglement [72].

6. Zero-dimensional number theory

The Temporal Mechanics proposal is to consider a new number theory approach beyond the black hole singularity proposal, beyond the calculus of QFT and GR breaking down, and thus the establishment of a novel zero-dimensional number theory for space and time as a new theoretic origin. Quite simply, the Temporal Mechanics proposal is to develop a zero-dimensional number theory for time and space and to then from that emerge a dimensional number theory that confirms the findings of QFT and GR, and not only that, confirms why the infinitesimal calculus of QFT must be **flat** 4d spacetime and why the infinitesimal calculus of GR must be **curved** 4d spacetime.

Temporal Mechanics considered the *GR inclusive*⁴⁵ and *QFT non-inclusive* inertial frame of reference *issue* and decided to work a non-inertial⁴⁶ zero-dimensional number theory for time and space, to thence form a zero-dimensional basis not dependent on mass and thence inertia per se, yet strictly a number theory basis for time and space on a zero-dimensional scale, and to then apply that number theory to dimensional analysis, as per its 56 papers [1-56].

The core consideration for the basis of the zero-dimensional number theory was the 0-∞ paradox, namely the size and scale of a point from 0 to ∞ if indeed nothing existed before the proposed big bang and yet that same thing still exists ahead of the shock front of the proposed big bang. Consider figures 9.1-9.3.

Figure 9.1

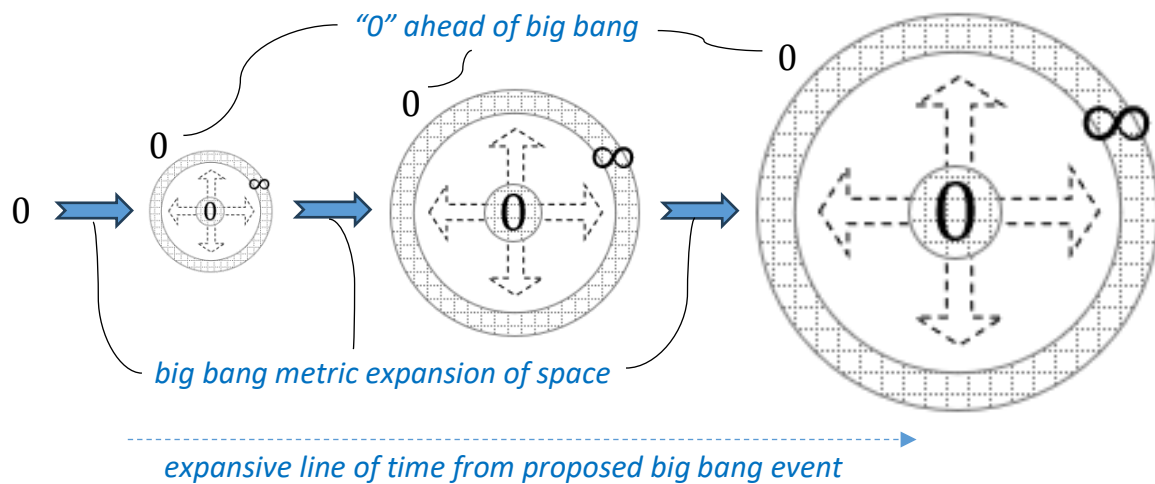

⁴⁵ As per the chosen priority of the GR-based Λ CDM cosmological model context.

⁴⁶ In therefore not using the GR-based Λ CDM cosmological model context.

Figure 9.2

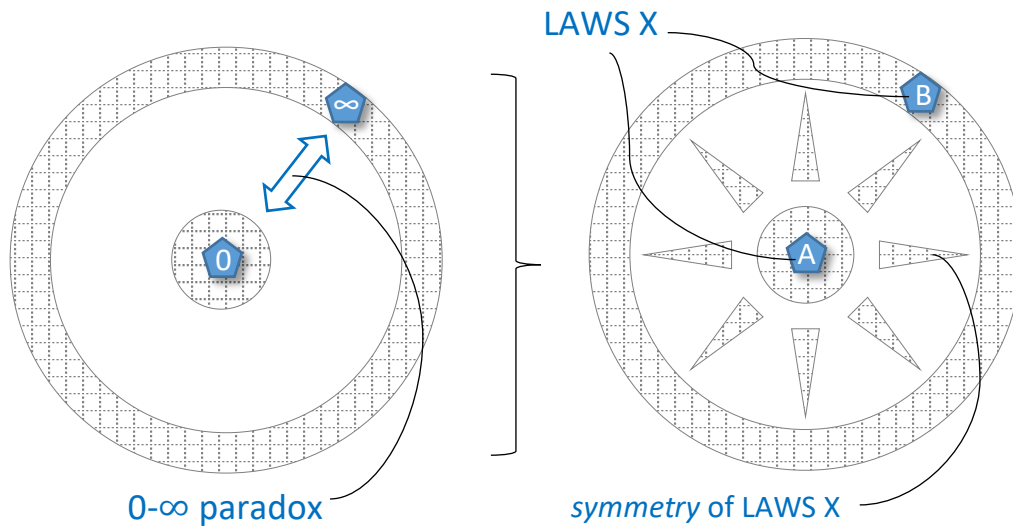
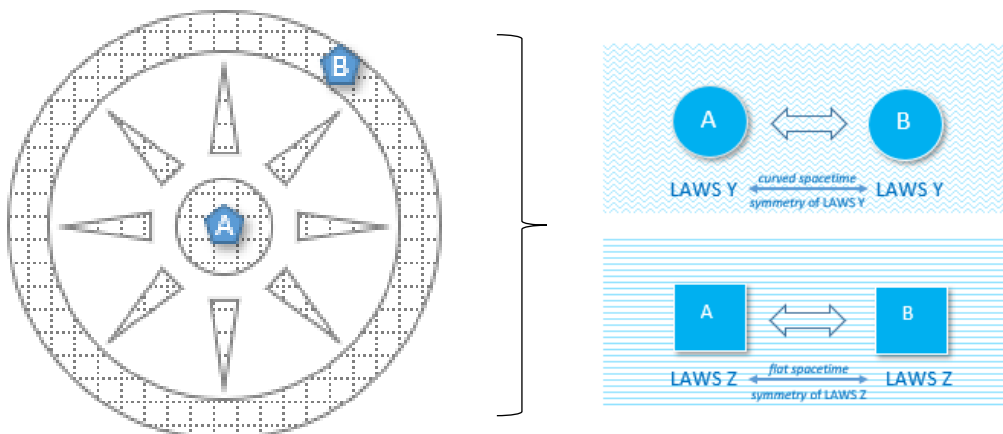

Figure 9.3



Figures 9.1-9.3: proposing the 0-∞ paradox as a zero-dimensional number theory encryption leading to the formulation of a singular “LAWS X” context/basis

What is this significance of the symmetry of “LAWS X” for physical phenomena though especially if nothing existed at the considered “0” start time of reality just before physics’ proposed big bang?

(A) Firstly, the “LAWS X” basis is aimed to identify a type of *cause* for the observed and theorized metric expansion of space⁴⁷ by proposing the 0-∞ scaling paradox which as a paradox aims to capture the scaling paradox of the point in space and moment in time that existed before the big

⁴⁷ Owing to the redshift of light from observed galaxies.

bang and how that relates with what exists ahead of the proposed Λ CDM metric expansion of space shock front, as per figures 9.1-9.3.

- (B) Secondly, the “LAWS X” basis is proposed to then allow for the resolution of all CMI⁴⁸ infinite-set number theory problems including Fermat’s conjecture⁴⁹.
- (C) Thirdly, the “LAWS X” basis as the proposed zero-dimensional number theory when scaled with the charge of the electron e_e , and speed of light c aims to then demonstrate:
- a. known features and associated data of GR and QFT to become evident,
 - b. and thence link QFT and GR by this “LAWS X” context/basis.

The core process here with Temporal Mechanics and associated zero-dimensional logic is as follows:

- (xxix) the creation of a zero-dimensional number theory for the pre-state (0-time and 0-space) of the big bang and thus also by proxy for that which exists *ahead* of that proposed big bang (also as 0-time and 0-space),
- (xxx) such (xxix), as an analysis of a zero-dimensional scaling paradox, namely the 0- ∞ scaling paradox, for time and space⁵⁰,
- (xxxi) such (xxx), which then represents a mathematical bridge linking the infinitesimal natures of QFT and GR,
- (xxxii) such (xxxi), as a process that when scaled with physical phenomena represent a feature to reality, namely as a fundamental field force effect,
- (xxxiii) such (xxxii), as a proposed *initial condition* for physical phenomena,
- (xxxiv) such (xxxiii), to thence highlight the features of the responsible fundamental field force effect and how it can be made use of.

Temporal Mechanics initiated this entire theoretic process in paper 1 [1] rather generally, surveying the broader landscape of the dimensional number theory issues for EM and gravity⁵¹.

There, having revealed a golden ratio (fractal) code for a dimensional time equation that related with the quantum shell nature of the atom in deriving the Rydberg equation⁵², the symposium was extended to how the time equation would derive what could only be a quantum wave function when scaled with the charge of the electron e_c and speed of light c , as per paper 2 [2].

⁴⁸ See section 5.

⁴⁹ See figure 8.

⁵⁰ [49]: p7-10.

⁵¹ [1]: p10-12.

⁵² [1]: p13-18.

The next logical step was to derive the Planck scale in paper 3 [3], noting the obvious issue there with the then rudimentary equations and associated constants in play. The task was thence to extend the theory as acutely and broadly as possible to refine the equations and their constants.

By paper 15 [15] a second equation was realized for space as the Euler identity equation as adapted to the golden ratio time equation.

Thence, through a series of papers [1-42] the zero-dimensional approach was reached in paper 43 [43] by:

- (xxxv) proposing zero-dimensional time and space as the next step ahead from the infinitesimal calculus approach, namely in going straight to an *absolute* infinitesimal level for time and space.
- (xxxvi) such (xxxv), by identifying a $0-\infty$ scaling paradox for a point in space⁵³.
- (xxxvii) thence resolving such (xxxvi) by:
 - a. defining the idea of zero-dimensional time and zero-dimensional space.
 - b. proposing two new temporal datum references, namely *time-before* and *time-after*, which thence are shown to derive dimensionality (3d) for space.
- (xxxviii) all of such thence becoming a new mechanics for the idea of time, hence the titled term Temporal Mechanics.

Thus, at its core Temporal Mechanics utilizes a number theory that represents a proposed way zero-dimensional time relates with zero-dimensional space where:

- (xxxix) 3d space is derived with an associated 1d arrow of time.
- (xl) The arrow of time (1d) is represented as a basic 1d time equation with 3d space termed as *3d timespace*⁵⁴, as $t_B + 1 = t_A$ where $t_B^2 = t_A$.
- (xli) 3d space is represented by an analogous equation to the *3d timespace*⁵⁵, as $e^{i\pi} + 1_{t_N} = 0_{t_A}$.

Consider figure 10 which describes the process of derivation for the zero-dimensional number theory as outlined in papers 43-56 [43-56].

⁵³ A process which then set a basis for an overall non-expanding space locale.

⁵⁴ This is analogous to *flat 4d spacetime*, noting that with the zero-dimensional number theory time as a dimension is concurrent with each dimension of space.

⁵⁵ This is analogous to curved 4d spacetime, noting once again that with the zero-dimensional number theory time as a dimension is concurrent with each dimension of space.

Figure 10

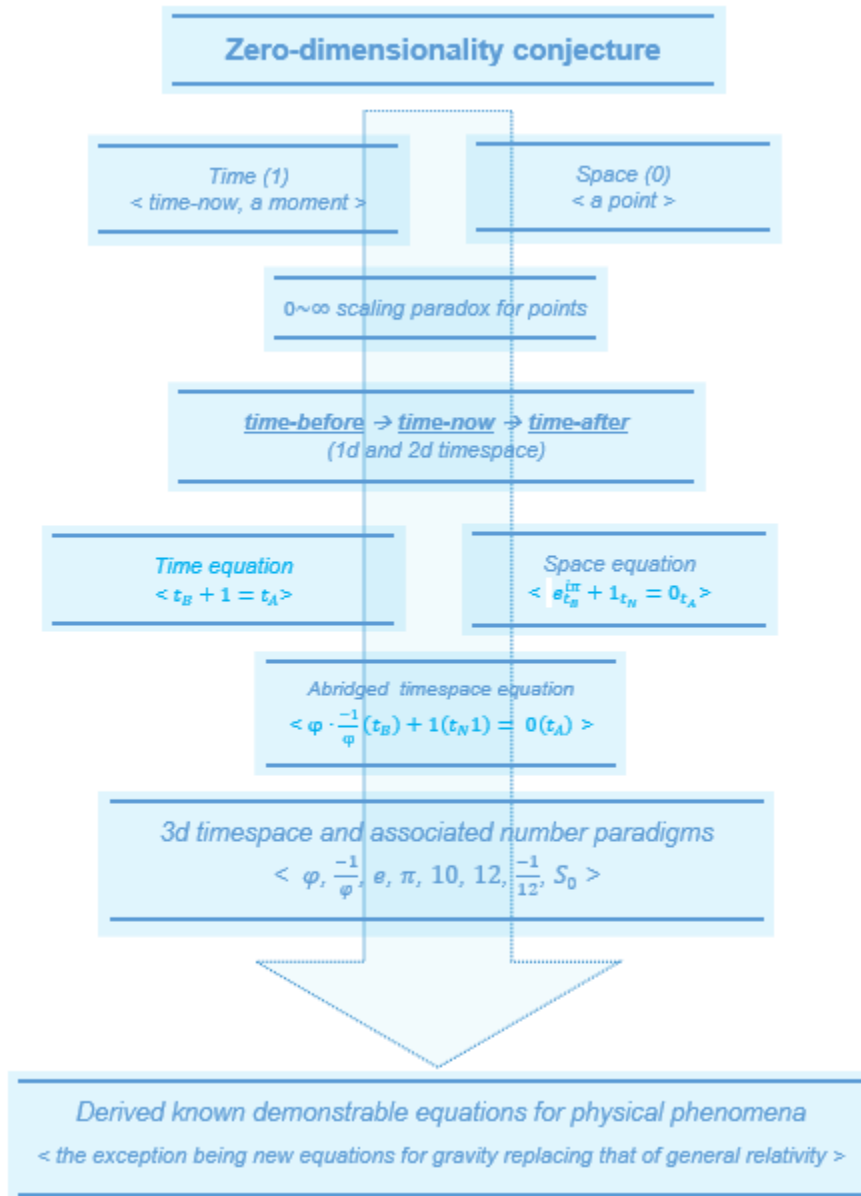

All of such is scaled with what the number theory identifies as the equations for the charge of the electron e_c and the speed of light c , revealing and thence resolving:

- (xlii) known dimensional phenomenal features and associated equations in physics as presented in papers 48 [48] and 49 [49].
- (xliii) known calculus problems with the aim of resolving those dimensional number theory problems as presented in papers 49 [49] and 55 [55]:

- a. Poincaré conjecture⁵⁶.
- b. Hodge conjecture⁵⁷.
- c. Riemann hypothesis⁵⁸.
- d. Birch and Swinnerton-Dyer conjecture⁵⁹.
- e. Yang-Mills existence and mass gap⁶⁰.
- f. Navier-Stokes existence and smoothness⁶¹.
- g. P versus NP⁶².
- h. Beal conjecture⁶³.
- i. Fermat's conjecture⁶⁴.
- j. Goldbach conjecture⁶⁵.

By this process, the fundamental physical phenomenal feature of this proposed new fundamental “initial condition” force became apparent. Consider figure 11.

Figure 11

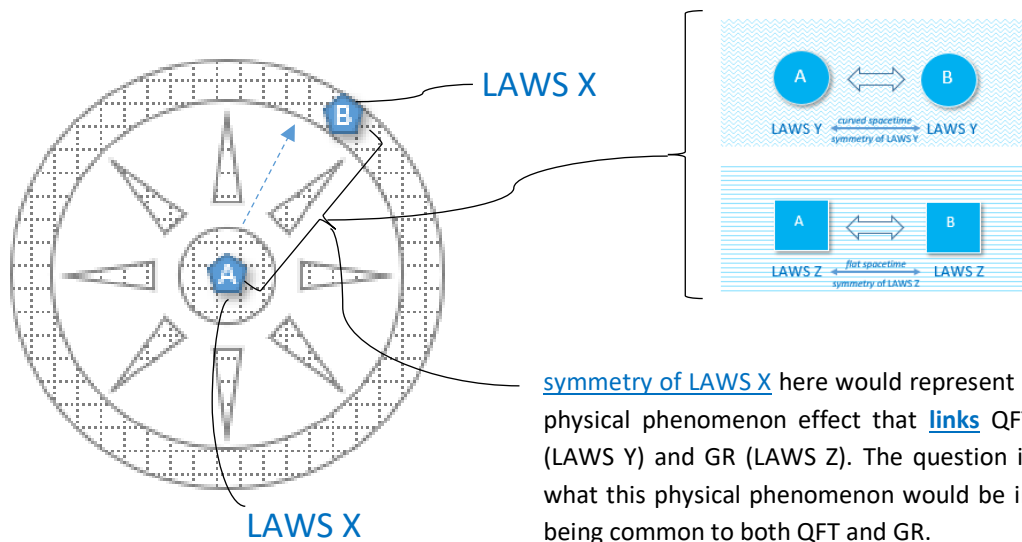

⁵⁶ [55]: p9-10, p21.

⁵⁷ [55]: p10, p21.

⁵⁸ [55]: p11, p21-22.

⁵⁹ [55]: p12, p22.

⁶⁰ [55]: p12-13, p22.

⁶¹ [55]: p13-14, p23.

⁶² [55]: p14-15, p24-25.

⁶³ [55]: p25-27.

⁶⁴ [55]: p17-18, p25-27.

⁶⁵ [49]: p16-18.

To note is the priority of the datum reference of *time-now*, specifically in the construction of a number theory framework for the dimensions of time and space on the presumption of physical reality executing itself in the datum-reference of *time-now*, thence conjecturing that:

- (xlv) time travel into the past and future, despite the connotation of the term “*temporal mechanics*”, is not feasible yet is confined to the datum reference of *time-now*⁶⁶.
- (xlv) temporal paradigms of *time-before* and *time-after* are though instrumental in creating dimensionality for zero-dimensional space.

Importantly to note is:

- (xlv) the results of Temporal Mechanics only apply to its designed context, namely *apparent static space*.
- (xlvii) the Λ CDM model proposes a universal *spatial expansion* based on the evidence for the redshift of light of galaxies⁶⁷.

How are such (xlv)-(xlvii) resolved?

The task for Temporal Mechanics was to focus on the derivation of the known phenomena of a static space locale and to cross-match those derivations with the data of a static-space locale such as this solar system, as per the following papers highlighting those derivations:

- (xlviii) spatial limit of solar system (Oort cloud)⁶⁸.
- (xlix) distance to hydrogen wall from *Sol*⁶⁹.
- (l) depth of Hydrogen wall⁷⁰.
- (li) CMBR value⁷¹.
- (lii) *Sol* mass⁷².
- (liii) *Sol* radius (general and coronal)⁷³.
- (liv) *Sol* temperature (core, surface, and coronal)⁷⁴.

⁶⁶ The exception being in the condition of the quantum/particle wave function as presented in paper 52 [52]: p5-18.

⁶⁷ With the Λ CDM model, the galaxies and their suns appear to exist in a static space locale suggesting the presence of cold dark matter (CDM) holding galaxies together in its broader proposed context of expanding space. It is also important to note that CDM has not been found to exist in a solar system locale, and that all modelling for our solar system presents the case for a stable spatial status quo.

⁶⁸ [13]: p11, eq6-8.

⁶⁹ [32]: p15-16.

⁷⁰ [32]: p16-17, eq6-9.

⁷¹ [14]: p25, eq13; [37]: p29-31.

⁷² [39]: p33-37.

⁷³ [39]: p61-62, p64-65.

⁷⁴ [39]: p59-63.

- (lv) Mercury perihelion⁷⁵.
- (lvi) The dynamic nature of the solar system⁷⁶

This (xlviii)-(lvi) is highlighted in figure 12⁷⁷; here, the scales of *Sol* are derived in using this *ab initio* zero-dimensional number theory and associated e_c and c scaling process, specifically in using the derived values of the fine structure constant (α) and Planck constant (h).

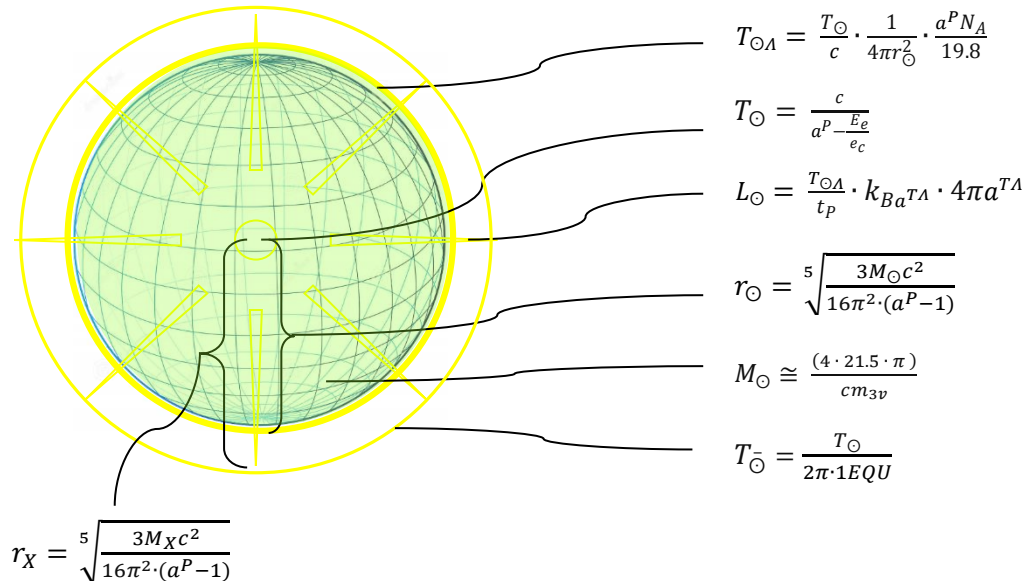

Figure 12: Highlighting the phenomenal features of *Sol* from the derived fine structure constant (α) and Planck (h) values.

Another core achievement was deriving the scale of the known solar system astrophysical firmaments from *Sol*, namely the Heliopause, Hydrogen wall, and Oort cloud, as per figure 13⁷⁸.

⁷⁵ [14]: p27-28; [51]:p11-14.

⁷⁶ The dynamic nature of the solar system is described throughout paper 42 [42] in view of the inherent mismatch between the time equation and space equation, between EM and gravity, always seeking to correct each other. Such a concept was also described in paper 3 [3] in deriving the chaos equation, thence followed up in paper 51 [51]: p14-17. See also paper 39 [39]: p65-67.

⁷⁷ [39]: p65, fig14.

⁷⁸ [39]: p66, fig15.

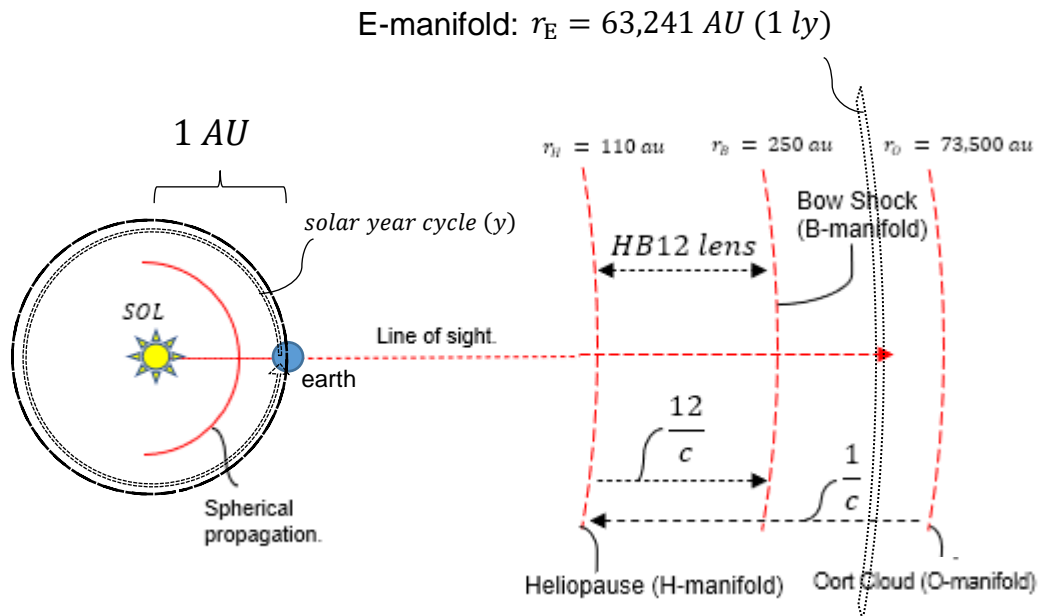

Figure 13: as per based on figure 1, paper 33 ([33]: p9, fig1), the distance of the r_E manifold is calculated using the idea of Earth as a solar year (y) reference as one revolution around ol in accompanying the propagation of light from Sol , calculating this value thence as 63,241 AU.

With all such achieved, noting how precisely well the zero-dimensional number theory and thence zero-dimensional physical theory⁷⁹ compared and confirmed the known physical phenomena equations and associated physics data of the solar system, together with the microscopic scale features of light and particles⁸⁰, two notable conditions became apparent, namely:

- (lvii) the description of light as per the time equation, described as the “*phi quantum wave function*”, as *flat timespace*⁸¹, namely $t_B + 1 = t_A$.
- (lviii) and the description of gravity, described based on spatial zero-point energy, as *curved timespace*⁸², namely $e^{i\pi} + 1_{t_N} = 0_{t_A}$.

In other words, the zero-dimensional number theory in proposing to be a more absolute infinitesimal description of the calculus processes for QFT and GR⁸³ presents the case that the equations and thence calculus for QFT must be different to that of GR, as they are. The finding therefore was that:

⁷⁹ Via the scaling process with the charge of the electron e_e and speed of light c .

⁸⁰ Subatomic and elementary particles.

⁸¹ [2]: p1-14; [52]: p12-32.

⁸² [42]: p22-55; [52]: p40-46.

⁸³ In being zero-dimensional and not infinitesimal.

- (lix) the description of EM is only possible via a flat spacetime approach in being independent of the derived *dimensional* nature of space, as per $t_B + 1 = t_A$ where $t_B^2 = t_A$.
- (lx) the description of gravity is only possible via a curved spacetime approach in being dependent on the derived *dimensional* nature of space, as per $e_{t_B}^{t\pi} + 1_{t_N} = 0_{t_A}$,

In fact, the zero-dimensional approach confirmed key issues known to the phenomena of quanta⁸⁴, mass⁸⁵, and gravity⁸⁶ for static (non-expanding) space.

7. Zero-dimensional holographic universe

To note is that this zero-dimensional and thence dimensional number theory when scaled⁸⁷ with known features of physical reality confirms all the known data and associated descriptions of QFT and GR relevant to a *static* spatial backdrop scenario, and so *may appear* to be unable to delve into expanding space Λ CDM cosmology theory. However, the basic design of the zero-dimensional number theory posed the question of what existed before the big bang and if that same thing that existed before the big bang exists ahead of the current expanding space context of the big bang Λ CDM model, thence arriving at the $0-\infty$ paradox for a point in space if indeed the big bang came from a point in space⁸⁸. This paradox was resolved in using the proposed time-domains of *time-before* and *time-after*⁸⁹. Upon such a basis, the zero-dimensional number theory when scaled with e_c and c was able to derive phenomena known to Λ CDM expanding space, a seemingly impossible task in not accounting for expanding space other than the scripting of the proposed $0-\infty$ scaling paradox in the context of the Λ CDM model. How was this “*expanding space*” effect achieved?

In clarifying this issue, namely how such *expanding space* phenomena and associated data was retrieved/derived from/within a static space locale, it is important to note the basis of the zero-dimensional number theory. For instance, paper 43 [43] proposed the hypothetical point that existed *before* the big bang would still presumably be *ahead* of the current big bang as highlighted in figures 9.1-9.3. By such, the zero-dimensional feature of Temporal Mechanics presented the window of view for the Λ CDM only regarding this *zero-dimensional* feature, and thence presumably, according to all the data, *phenomena in non-expanding space*⁹⁰. Nonetheless, in apparent reproach to the Λ CDM expanding space model, the

⁸⁴ [52]: p12-36, p46-49.

⁸⁵ [52]: p36-40, p46-49.

⁸⁶ [52]: p40-49.

⁸⁷ Using the speed of light c and charge of the electron e_c .

⁸⁸ As per paper 43 [43]: p2-5; see also figures 9.1-9.3.

⁸⁹ [43]: p6-8.

⁹⁰ Thence solar system phenomena, noting that GR implies it is the space around observed galactic phenomena that is expanding care of dark energy, whereby galaxies are held together and thence not expanding care of dark matter.

phenomena and thus information of what appear to be unique solar systems beyond this solar system, namely stars and galaxies, are derived by Temporal Mechanics through a newly discovered zero-dimensional number theory feature. There, a key discovery by the zero-dimensional number theory is a phenomenon not currently considered or scouted by physics, the “*electron degeneracy*” phenomenon which as the name suggests describes how the electron is derived to annihilate⁹¹, specifically to the level of a neutrino. There, that process is derived to represent a type of particle fission process of the electron into neutrinos, such as phenomena giving off the effect of miniature suns perceived as stars.

The region in the solar system where this *electron degeneracy* effect is derived to occur is in the Hydrogen wall, a region that then by its relationship to the derived 3d timespace⁹² outer structure of the solar system leads to a holographic display of electron degeneracy events *beyond* the solar system, presenting the effect of a universe of stars and galaxies with associated spatiotemporal data, namely information *mimicking* the existence of stars and galaxies (including back holes) despite the overall context of its zero-dimensional and thence presumably complete zero-point status. This holographic display of astrophysical phenomena is described in papers 32-35 [32-35]. There, the *axis of evil* and *horizon* problems are accounted for by the zero-dimensional number theory⁹³.

The astrophysical landscape as described in papers 33⁹⁴ and 34⁹⁵ became apparent via the proposed/derived r_E E-manifold context as the focus itself of virtual light activity filtered/adjusted through the derived $H_c TSG$ and associated *HB12* schemes ([33]: p13-16, fig4-7), thence leading to the holographic display of astrophysical phenomena as per figure 14.

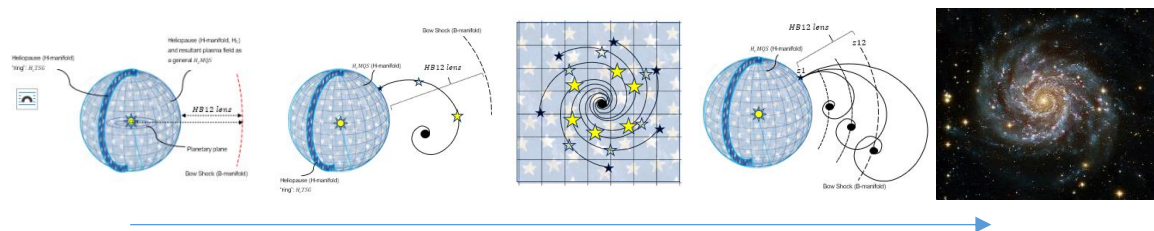

Figure 14: $r_H TSG$ and associated *HB12* scheme from paper 33 ([33]: p13-16, fig4-8)

Such presented a case for a virtual/holographic universe of stars with our *Sol* being a part of a galaxy among billions of *virtual* galaxies each holding billions of *virtual* suns themselves. There, Temporal Mechanics accurately derived the Λ CDM’s age of the universe, the distance to the apparent closest star

⁹¹ Such, in the context of a derived *maximum solar system mass* event scenario [39]: p41-47.

⁹² See paper 52 ([52]: p8, xviii) for the definition of 3d timespace.

⁹³ Specifically, paper 32 [32], summarized in paper 50 [50].

⁹⁴ [33]: p5-19.

⁹⁵ [34]: p23-32.

Proxima Centauri, the apparent number of stars in our apparent galaxy, and the number of apparent galaxies in the apparent universe of stars⁹⁶, including:

- (Ixi) the number of galaxies to be estimated between 200 billion to 2 trillion, depending on how the data is being processed.
- (Ixii) the number of stars in the Milky Way to approximately number 400 billion.
- (Ixiii) the age of the Universe to be 13.8 billion years, as according to the metric expansion of space Λ CDM model and associated star-light data available.
- (Ixiv) Proxima Centauri measured to be the closest star from *SOL* at 4.246 AU.

Such is not to say that the universe is not as GR based Λ CDM model proposes, yet that *in an absolute zero-dimensional context* the *information* of reality can be modelled if not contained and retrieved, an idea scouted by current black hole theorists [73][74], an idea though *derived* here by this new zero-dimensional number theory, suggesting how on a zero-dimensional level QFT and GR information is in fact *preserved*.

Consider figure 15 to describe this.

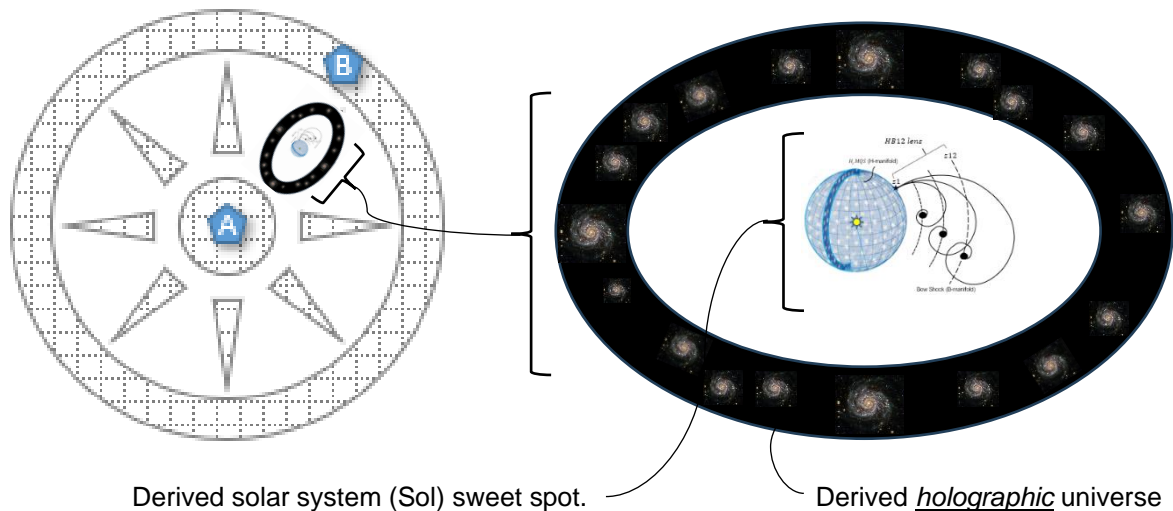

Figure 15: (*not drawn to temporal or spatial scale*) the universal “sweet spot”, noting the zero-dimensional number theory correctly derived the “non-existence” feature of the universe (as a hologram in this case) given the zero-dimensional number theory takes the context of the moment at the big bang.

Significantly, the zero-dimensional number theory correctly derives a holographic and thence illusionary universe as per its zero-dimensional basis, namely based on the 0-time and 0-space condition

⁹⁶ [34]: p30.

just before the big bang event, yet still identifies a “real” component in the big bang’s time-line of development, as what would appear to be the sweet-spot, namely the “blueprint” for the overall 0-∞ paradox filtered Λ CDM event **as this solar system**. This is a significant finding, as it implies a certain *archetypal significance* of this solar system in the context of the universe.

The key limitations nonetheless of the Temporal Mechanics zero-dimensional number theory are:

- (lxv) how the zero-dimensional number theory is designed to perform based on how numbers are employed to label zero-dimensional time and zero-dimensional space,
- (lxvi) thence how dimensional space is proposed to emerge from the *time-before* and *time-after* paradigms,
- (lxvii) thence how the number theory can only at best be applied to known observed features of physical reality care of dimensional physics, and thence infinitesimal calculus and associated physical phenomena-based data as tested by QFT and GR.

8. The zero-point gravitational field (Xemdir)

Considering the confirmed findings of the zero-dimensional number theory when scaled with physical phenomena, proposed here therefore is the improbability of finding a dimensional infinitesimal calculus link between QFT and GR. Such is not to say that a dimensional number theory link between higher and lower dimensions is not able to link QFT and GR as a quantum gravity theory, yet here the proposal is to make use of the calculated, derived, and thence known incompatibility of the current number theory structure between QFT and GR.

Zero quantum gravity (0QG) is a term given to the idea of not focusing on the quest for dimensional quantum gravity yet that a pure number theory link between QFT and GR can be found via a zero-dimensional number theory approach. As such, 0QG is not proposed to be a new phenomenon per se yet a new paradigm of the zero-dimensional number theory that proposes how the dimensional mismatch between QFT and GR can be accounted for and made use of, here as how EM and zero-point space can be both described and utilized.

As presented, the zero-dimensional number theory demonstrates how space is proposed to be held together without expanding. This “holding together” of space is described mathematically by the space equation, as the zero-point gravity equation, namely $e_{t_B}^{t\pi} + 1_{t_N} = 0_{t_A}$. There, in that zero-dimensional description, gravity at its core is derived to be non-inertial and zero-point, such by the nature of its equation, namely in equating to 0. Such though does not make space potentially non-expansive, as the basis of the zero-dimensional number theory is precisely that, a number theory, and not based on observation and measurement yet pure number theory. However, the zero-dimensional number theory approach presents an exclusive view of an *absolute* infinitesimal (zero-dimensional) approach to the dimensions, which would thus represent a valid ingredient to dimensionality to be explored and verified with data which it has both aimed to and demonstrated itself to achieve.

Once again to note are figures 9.1-9.3 describing the $0-\infty$ paradox and how that was considered in the context of the Λ CDM model⁹⁷. There, it is important to note that the static space condition of the zero-dimensional number theory does derive the condition of a zero-point gravity describing static space and how such then forms the basis for what is derived to be a *solar system* as per figures 11-13. These theoretic proposals have no change to the known data of the proposed QFT and GR static space phenomena in the context of the perceived Λ CDM model, specifically the expanding universe description of dark energy (Λ) and cold dark matter (CDM). In fact, the proposals of the zero-dimensional number theory have utilized all QFT and GR data while then proposing a basis for *apparent* expanding space, thence providing a proxy description for dark energy (Λ) and cold dark matter (CDM).

The primary problematic issue for the proposed 0QG results⁹⁸ is found through the lens of quantum field theory (QFT) and general relativity (GR), namely by the 0QG proposal when *EM* undergoes absolute destructive interference resonance (*DIR*) then the question arises for QFT and GR as to where does that energy go, and why that proposed *DIR* process and associated zero-point energy result would resist *EM* (electromagnetic), EM^{DIR} (mass), and $EM-EM^{DIR}$ (electric and magnetic) fields. Thus, the question for QFT and GR physics there is what this zero-point energy field means to their dimensional constitution descriptions of flat and curved 4d spacetime. Simply, would this new 0QG phenomenon be a new fundamental zero-point energy field that has escaped the attention of QFT and GR physics that can nonetheless be incorporated into QFT and/or GR? To answer that question is to ask what the fundamental processes in play are proposed to be for the 0QG proposal as outlined in paper 53 [53], namely:

- (lxviii) the *complete* destructive interference resonance (*DIR*) of opposing in-phase *EM* (θ) fields.
- (lxix) a $EM_X^{DIR}(\theta_\phi)$ manifesting field effect that creates a potential energy gradient thence kinetically repelling $EM-EM^{DIR}$, namely *EM* and mass.
- (lxx) a $EM_X^{DIR}(\theta_\phi)$ manifesting field effect that is both:
 - a. zero-point:
 - i. Namely a repulsion effect on *EM* (θ) and mass (θ_ϕ).
 - b. zero-point inertial and thus non-inertial:
 - i. As otherwise there would be a kick-back effect on the $EM_X^{DIR}(\theta_\phi)$ zero-point field by *EM* (θ) and mass.

One Λ CDM interpretation of this proposed 0QG $EM_X^{DIR}(\theta_\phi)$ field phenomenon according to QFT and GR is that this zero-point 0QG energy⁹⁹ could in fact represent both:

⁹⁷ As based on the physical data modelling and structuration of QFT and GR.

⁹⁸ As the proposed electric and magnetic thrust, and plasma generation tests [53]: p7-24.

⁹⁹ Derived as the $EM_X^{DIR}(\theta_\phi)$ field phenomenon.

- (lxxi) a dark energy (Λ) mechanism in being a zero-point *dispersive* energy owing to being repulsive to EM and mass.
- (lxxii) a cosmologically scaled cold dark matter (CDM) phenomenon in being repulsive to EM and mass thence leading to a resultant attraction of EM and mass¹⁰⁰.

To note is that this proposed 0QG $EM_X^{DIR}(\theta_\phi)$ field phenomenon is not exclusively the idea of mass becoming hyper-massive and thence collapsing in on itself. Here with this proposed 0QG $EM_X^{DIR}(\theta_\phi)$ field phenomenon is the idea of EM undergoing strict destructive interference resonance (DIR) that would then accentuate a zero-point energy field¹⁰¹ that is derived to repel (and not attract) both EM (θ) and mass (EM^{DIR}, θ_ϕ), and thence repel $EM-EM^{DIR}$ static charge and magnetic fields. There is potential discussion therefore to be had with GR theory about:

- (lxxiii) the possibility of this 0QG $EM_X^{DIR}(\theta_\phi)$ field being a ground state Λ zero-point energy field relaying such an effect, the problem there being the non-exclusivity of both a maximum-mass event horizon and metric expansion of space.
- (lxxiv) the resultant gravitational field effect of this 0QG $EM_X^{DIR}(\theta_\phi)$ field, namely on an apparent cosmological scale giving the effect of cold dark matter (CDM).

9. The zero-point gravitational field (Xemdir) thruster

For physics to investigate and describe the nature of mass is elementary. Here though the proposal is the inclusion of a zero-dimensional number theory intrinsic to both QFT and GR, arrived at through a step beyond infinitesimal calculus. By such, the proposal here is that the zero-dimensional number theory can demonstrate:

- (lxxv) how the different dimensional descriptions QFT and GR are harnessed in the zero-dimensional number theory proposed window/context of static 3d space and arrow of 1d time, described in Temporal Mechanics as 3d *timespace*¹⁰².
- (lxxvi) the zero-inertial zero-point reference is free from the design requirements and associated constraints of QFT and GR, namely in not being mass and thence inertial based.

In demonstration of the zero-dimensional number theory, the idea here is to reproduce experimentally how a proposed quantum wave function¹⁰³ executes destructive interference resonance

¹⁰⁰ As proposed in paper 53 [53]: p3-7.

¹⁰¹ Abiding by all *conservation of energy* principles.

¹⁰² So as not to confuse this new process with the standard *spacetime* dimensional approach.

¹⁰³ The zero-dimensional number theory analogue of a photon.

(*DIR*) in creating a null wave function that is thence proposed to represent a zero-inertial zero-point field that nonetheless opposes both mass and EM.

The theory for this demonstration is provided in papers 52 [52] and 53 [53]. There, paper 52 [52] describes the *analogous* descriptions of QFT and GR, and then how such can be used to create a *DIR* zero-point (0QG) zero-inertial field. Paper 53 [53] then presents three key experiments to confirm this 0QG paradigm utility.

In taking the basic magnetic thruster design of paper 53¹⁰⁴, an experiment can be proposed as per figures 14-16.

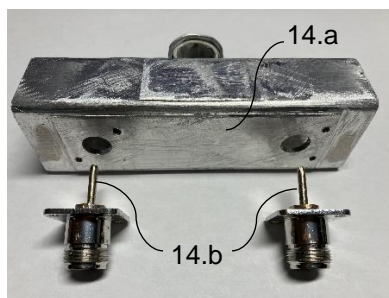

Figure 14: resonance chamber (14.a) and aerials (14.b) calibrated for a 5.8 GHz field, here the aerials separated by $1\frac{1}{2}\lambda$, chamber length $2\frac{1}{2}\lambda$.

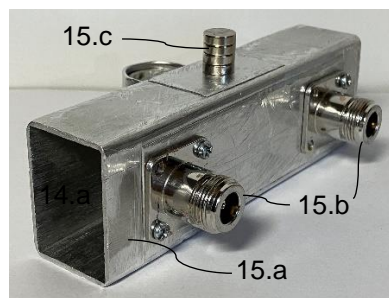

Figure 15: resonance chamber (15.a), attached aerials (15.b), and attached magnet (15.c) mounted perpendicularly midway between aerials on side wall.

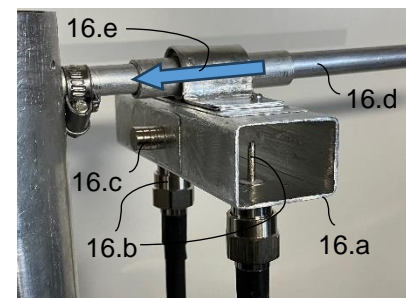

Figure 16: resonance chamber (16.a), aerials (16.b), magnet (16.c), horizontal suspension track (16.d), and proposed direction of thrust (16.e).

The proposed results of this most basic albeit preliminary 0QG thruster apparatus would aim to demonstrate that on activation of the chamber introduced 5.8 GHz field via the antennae there would be generated a zero-inertial zero-point EM_X^{DIR} field. The presence of this EM_X^{DIR} field would be confirmed by the measurable and consistent force against the introduced magnetic field by the measurable and consistent resultant thrust of the overall resonance chamber apparatus. There, the following process is proposed:

- (lxxvii) an EM_X^{DIR} test to be run a minimum of 5 times for a period of 5 seconds¹⁰⁵ with EM magnetic field attachment, ideally each test with the same result, as a measured movement of the chamber device along the horizontal track consistent with the EM_X^{DIR} field opposing the EM magnetic field.
- (lxxviii) the EM_X^{DIR} test to be run 5 times for a time of 5 seconds without EM magnetic field integration, ideally each test with no result.

¹⁰⁴ See paper 53 [53]: [0001]-[0085] p8-16, fig3 p18, (xxi)-(xxxvi) p22-23.

¹⁰⁵ This short period of time is owing to the design/structure limitations of the equipment preventing longer and more frequent testing as described in paper 53: [53]: p22, (xxi)-(xxvi).

- (lxxix) a non- EM_X^{DIR} test (chamber length **not** properly scaled) to be run 5 times for a time of 5 seconds **with** EM magnetic field integration, ideally each test with **no** result.

These preliminary tests would confirm:

- (lxxx) the requirement for the zero-dimensional number theory quantum/ EM scaling principle for the zero-inertial zero-point EM_X^{DIR} field description and demonstration.
- (lxxxii) the Xemdir field effect as a zero-point gravity field as a zero-point field effect repelling any field disruption source.
- (lxxxiii) a spatial equation borne feature that is a part of the chaos equation for time¹⁰⁶ as a feature that is enhanced in this Xemdir field generation process, namely an apparent chaotic yet distinct repulsive effect.

9. Zero-dimensional number theory: overview

It is important to note in view of the proposed results that the zero-point gravity field is *atypical* by its nature, as zero-dimensionality is in comparison to infinitesimal calculus and associated theory developments. Yet by the zero-dimensional number theory several physical phenomena features physics cannot explain can be explained:

- (lxxxiii) time's arrow¹⁰⁷.
- (lxxxiv) entropy¹⁰⁸.
- (lxxxv) baryon asymmetry¹⁰⁹.
- (lxxxvi) fine structure constant¹¹⁰.
- (lxxxvii) chaos equation describing randomness and thence Brownian motion¹¹¹.
- (lxxxviii) the *axis of evil* problem¹¹².
- (lxxxix) the *horizon* problem¹¹³.

The unanimous feature of concern for physics in any of its fields is the description of physical phenomena that defies physics' own current known theories for light and mass, namely phenomena that defies QFT and GR description processes. Such an unavoidable issue is so for the zero-dimensional

¹⁰⁶ [49]: p10-16.

¹⁰⁷ [49]: p10-16.

¹⁰⁸ [42].

¹⁰⁹ [42].

¹¹⁰ [39].

¹¹¹ [3][30][51].

¹¹² [32].

¹¹³ [32].

zero-point gravity force being atypical by its nature, by its genesis, namely by its zero-dimensional description origin. Without the zero-dimensional approach though the only alternative to such is in using mass and infinitesimal calculus and thence reaching QFT and GR.

In more carefully considering the zero-dimensional number theory approach and associated issues of description for GR and QFT, the following need to be considered:

- (xc) the idea of “extending” dimensionality from a zero-dimensional basis is explored,
- (xci) such (xc), as what is proposed to emerge as a *repulsive* effect of a zero-point time-space field,
- (xcii) such (xci), thence representing an absolute time-space barrier repelling both EM and mass.
- (xciii) such (xcii), proposed here as the *overall* resultant observed force of gravity.
- (xciv) such (xciii), not as QFT or GR, yet as a more fundamental field force working in alliance with QFT and GR, as that *zero quantum gravity* bridge between the two,
- (xcv) such (xciv), as an eternally potential repulsive field basis as the “cause” that existed before the big bang and thus ahead of the big bang shock front of time and space.
- (xcvi) such (xcv), as a force that moulds dimensionality of time and space into the shape it is perceived in,
- (xcvii) such (xcvi), therefore as a force that moulds the physical constants and associated equation descriptions they are calculated as,
- (xcviii) such (xcvii), as a field force effect that seeks to restore and uphold those physical constants and associated equations when it as a field force effect is generated,
- (xcix) such (xcviii), all in the one general zero-dimensional time and zero-dimensional space context.

The gravitational field effect¹¹⁴ by such represents the very zero-dimensionality of time and space the dimensional systems of time and space are established upon incorporating the ideas of the before event of the big bang and thence what’s still ahead of the big bang as a code as a zero-dimensional field as a type of repulsive effect from the zero-dimensionality keeping the laws of physics in play (see figure 17). As described in section 7, this results in an apparent steady state solar system and associated holographic depiction of the stars beyond. See figure 17.

¹¹⁴ [47].

Figure 17

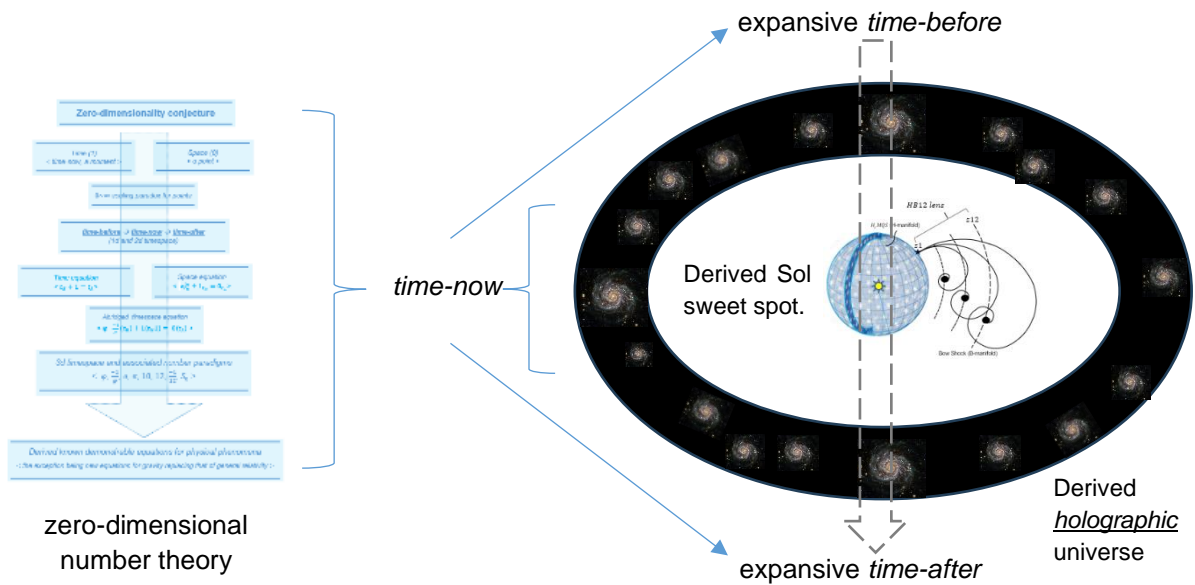

The derivation here for the solar system and the associated context of the generation of the holographic stellar effect is a background gravitational wave field effect. The metric of this background gravitational field is logically, as it can only be, the diameter of this solar system (~1 ly). This gravitational wave field effect, given its backdrop nature to the holographic projection of the stars, would appear to be a background gravitational field effect as a wave in the context of the entire universe of apparent stars. This value is known to physics as the gravitational wave background [75][76]. This is in alliance with the Temporal Mechanics derived CMBR value¹¹⁵ of 160 GHz, also derived to be an apparently uniform value as the EM radiation background to the apparent universe of stars, as it only can be observed to be.

The idea therefore of the zero-dimensional number theory and its generated dimensional model of physical phenomena presents some clear consistencies with historical and current data. And that's what the theory presents, namely a "model", merely as a way of holding what is perceived of the dimensions and that associated data in a particular context of discussion, namely the context of the proposed zero-infinity paradox. By all of such, the zero-dimensional number theory presents a model that can be tested with data, as any model should.

In all, the zero-dimensional number theory model presents testing capability by deriving and subsequently identifying:

- (c) the general constitutional astrophysical time and space numerology of the universe in the context of the holographic appearance of the universe of stars¹¹⁶:

¹¹⁵ [37].

¹¹⁶ [34].

- a. the age of universe.
- b. the general number of stars and grouping traits.
- c. the constitution of stars.
- (ci) the general CMBR value in the context of the holographic appearance of the universe of stars¹¹⁷.
- (cii) the general background gravitational wave effect in the context of the holographic appearance of the universe of stars.

This result is perhaps significant, as it suggests that if the Λ CDM model is valid then:

- (ciii) the data of the perceived universe can be accurately measured using the physical theories of QFT and GR.
- (civ) the data framework of the perceived universe can be derived as a zero-dimensional number theory bridging QFT and GR via a holographic astrophysical scaling process as confirmed by the data of the QFT and GR models and associated proposed zero quantum gravity phenomena¹¹⁸.
- (cv) the perceived universe can be measured and derived from within the universe at a certain stage of its development, namely in this current time of the proposed development of the perceived universe.

Of course, here the idea of being theoretic and thus conscious as a process of universal modelling poses new standards, namely:

- (cvi) the basic idea of a virtual model of the perceived universe within the universe itself in *using* the idea of consciousness in that virtual modelling process could indeed as a process be an *emergence* from the perceived universe's development, if not a feature of its sweet spot of development in time.
- (cvii) the development of the sciences and technologies of these models would represent a key to exploring that same perceived universe in confirmation of the universe's constitution.
- (cviii) the development of perception and thus perceptive development would also represent keys to understanding how to access the perceived universe.

Of course, these conclusions may seem intuitive, yet here they are derived from the zero-dimensional number theory when scaled with the charge of electron e_c and speed of light c while utilizing the general ecosystem of physical phenomena descriptors of QFT and GR.

¹¹⁷ [37].

¹¹⁸ As a proxy for dark energy (Λ) and dark matter (CDM).

10. Conclusion

Although much of the emphasis today in physics is on resolving the dimensional mismatch between QFT's flat 4d spacetime and GR's curved 4d spacetime, the proposal here has been to focus on how to best make use of that very well calculus-structured mismatch. Here with the *zero quantum gravity proposal* the intention is not to disrupt or dispel the current quests for quantum gravity, yet to offer a theoretic and experimental utility to the known mismatch between QFT and GR. Thus, a zero-dimensional number theory is pursued to both confirm the mismatch and confirm the known data of QFT and GR, as it should. By such, the zero-dimensional number theory presents a new way of utilizing the mismatch between QFT and GR *experimentally* as *zero quantum gravity (0QG)*. There, the zero-dimensional QFT and GR bridging/analogous theories are presented in paper 52 [52] and thence a demonstration of the 0QG field effect (EM_X^{DIR} field) is proposed in paper 53 [53]. The question that needs to be asked is regarding the significance of the 0QG model given its interpretation of stellar phenomena.

Conflicts of Interest

The author declares no conflicts of interest; this has been an entirely self-funded independent project.

References

1. Jarvis S. H. (2017), <https://doi.org/10.13140/rq.2.2.35132.28804/1>, https://www.researchgate.net/publication/328738261_Gravity's_Emergence_from_Electrodynamics, <https://vixra.org/abs/1704.0169>
2. Jarvis S. H. (2017), <https://doi.org/10.13140/rq.2.2.30099.12327/4>, https://www.researchgate.net/publication/328738109_Golden_Ratio_Axioms_of_Time_and_Space, <https://vixra.org/abs/1706.0488>
3. Jarvis S. H. (2017), <https://doi.org/10.13140/rq.2.2.23388.23683/2>, https://www.researchgate.net/publication/328738518_The_Emergence_of_Consciousness_from_Chaos, <https://vixra.org/abs/1707.0044>
4. Jarvis S. H. (2017), <https://doi.org/10.13140/rq.2.2.10045.10726/5>, https://www.researchgate.net/publication/328738422_Phi-Quantum_Wave-Function_Crystal_Dynamics, <https://vixra.org/abs/1707.0352>
5. Jarvis S. H. (2017), <https://doi.org/10.13140/rq.2.2.23466.88009/3>, https://www.researchgate.net/publication/328738526_Time_as_Energy <https://vixra.org/abs/1711.0419>
6. Jarvis S. H. (2018), <https://doi.org/10.13140/rq.2.2.13400.55044/4>, https://www.researchgate.net/publication/328738389_The_Relativity_of_Time <https://vixra.org/abs/1801.0083>

7. Jarvis S. H. (2019), <https://doi.org/10.13140/rq.2.2.27741.26089/2>,
https://www.researchgate.net/publication/332672475_Golden_Ratio_Entropic_Gravity_Gravitational_Singularity_Field_Testing, <https://vixra.org/abs/1904.0485>
8. Jarvis S. H. (2019), <https://doi.org/10.13140/rq.2.2.35399.14246/2>,
https://www.researchgate.net/publication/332879052_The_Golden_Ratio_Time_Algorithm,
<https://vixra.org/abs/1905.0081>
9. Jarvis S. H. (2019), <https://doi.org/10.13140/rq.2.2.28499.02084/1>,
https://www.researchgate.net/publication/333668324_The_Physics_Chimera,
<https://vixra.org/abs/1906.0127>
10. Jarvis S. H. (2019), [10.13140/RG.2.2.10258.71363/2](https://doi.org/10.13140/RG.2.2.10258.71363/2),
https://www.researchgate.net/publication/333972239_The_Conception_of_Time,
<https://vixra.org/abs/1906.0441>
11. Jarvis S. H. (2019), <https://doi.org/10.13140/rq.2.2.15833.67689/1>,
https://www.researchgate.net/publication/335232726_Space_and_the_Propagation_of_Light
<https://vixra.org/abs/1908.0388>
12. Jarvis S. H. (2019), <https://doi.org/10.13140/rq.2.2.17320.93443>,
https://www.researchgate.net/publication/336130560_Space_and_the_Nature_of_Gravity,
<https://vixra.org/abs/1909.0656>
13. Jarvis S. H. (2019), <https://doi.org/10.13140/rq.2.2.14287.43683/2>,
https://www.researchgate.net/publication/337019159_Space_and_the_Redshift_Effect,
<https://vixra.org/abs/1911.0064>
14. Jarvis S. H. (2019), <https://doi.org/10.13140/rq.2.2.25730.63686/2>,
https://www.researchgate.net/publication/338159068_Solving_the_Cosmological_Constant_Problem,
<https://vixra.org/abs/1912.0451>
15. Jarvis S. H. (2020), <https://doi.org/10.13140/rq.2.2.13078.91205/3>,
https://www.researchgate.net/publication/338548474_Hybrid_Time_Theory_Euler's_Formula_and_the_Phi-Algorithm, <https://vixra.org/abs/2001.0233>
16. Jarvis S. H. (2020), <https://doi.org/10.13140/rq.2.2.27053.64487/3>,
https://www.researchgate.net/publication/338689227_The_Hybrid_Time_Clock_as_a_Function_of_Gravity
<https://vixra.org/abs/2001.0401>
17. Jarvis S. H. (2020), <https://doi.org/10.13140/rq.2.2.20045.79847/2>,
https://www.researchgate.net/publication/340270768_Hybrid_Time_Theory_Cosmology_and_Quantum_Gravity_I, <https://vixra.org/abs/2003.0659>
18. Jarvis S. H. (2020), <https://doi.org/10.13140/rq.2.2.16207.84648/1>,
https://www.researchgate.net/publication/340574420_Scientific_Principles_of_Space_Time_and_Perception, <https://vixra.org/abs/2004.0260>
19. Jarvis S. H. (2020), <https://doi.org/10.13140/rq.2.2.23972.22405/1>,
https://www.researchgate.net/publication/341117279_Hybrid_Time_Theory_Cosmology_and_Quantum_Gravity_II, <https://vixra.org/abs/2005.0053>
20. Jarvis S. H. (2020), <https://doi.org/10.13140/rq.2.2.34441.67683/6>,
https://www.researchgate.net/publication/341440377_Mathematical_Principles_of_Time_and_Energy,
<https://vixra.org/abs/2005.0179>

21. Jarvis S. H. (2020), <https://doi.org/10.13140/rg.2.2.21001.88169/1>,
<https://www.researchgate.net/publication/341782076> Dimensional Mechanics of Time and Space,
<https://vixra.org/abs/2005.0286>
22. Jarvis S. H. (2020), <https://doi.org/10.13140/rg.2.2.29715.71202/3>,
<https://www.researchgate.net/publication/342343657> Dimensional Thermodynamics,
<https://vixra.org/abs/2006.0194>
23. Jarvis S. H. (2020), <https://doi.org/10.13140/rg.2.2.10565.68320/3>,
<https://www.researchgate.net/publication/343281767> Time-Space Wave-Mechanics,
<https://vixra.org/abs/2007.0223>
24. Jarvis S. H. (2020), <https://doi.org/10.13140/rg.2.2.15362.09929/3>,
<https://www.researchgate.net/publication/343678982> Temporal Calculus The Calculus of Time-Points in Space, <https://vixra.org/abs/2008.0111>
25. Jarvis S. H. (2020), <https://doi.org/10.13140/rg.2.2.33774.43843/3>,
<https://www.researchgate.net/publication/343987838> Temporal Calculus solving the Yang-Mills Existence and Mass Gap problem, <https://vixra.org/abs/2008.0226>
26. Jarvis S. H. (2020), <https://doi.org/10.13140/rg.2.2.28539.75043/2>,
<https://www.researchgate.net/publication/344221574> Temporal Calculus Time Scaling Space,
<https://vixra.org/abs/2009.0091>
27. Jarvis S. H. (2020),
<https://doi.org/10.13140/rg.2.2.20191.07844><https://www.researchgate.net/publication/344387016> Temporal Calculus Resolving Elementary Particle Formation and Confinement,
<https://vixra.org/abs/2009.0177>
28. Jarvis S. H. (2020), <https://doi.org/10.13140/rg.2.2.12474.21447/2>,
<https://www.researchgate.net/publication/344457690> Temporal Calculus Resolving Einstein's Theory of Relativity Special and General, <https://vixra.org/abs/2010.0017>
29. Jarvis S. H. (2020), <https://doi.org/10.13140/rg.2.2.12651.98086/1>,
<https://www.researchgate.net/publication/345127477> Time and Non-Locality Resolving Bell's Theorem,
<https://vixra.org/abs/2011.0002>
30. Jarvis S. H. (2020), <https://doi.org/10.13140/rg.2.2.11032.83206/4>,
<https://www.researchgate.net/publication/346672010> Non-Local Time-Point Theory Magnetic Quantum Shell MQS Modelling, <https://vixra.org/abs/2012.0040>
31. Jarvis S. H. (2021), <https://doi.org/10.13140/rg.2.2.28879.10407/1>,
<https://www.researchgate.net/publication/348184426> Temporal Mechanics A Time-Space Circuits,
<https://vixra.org/abs/2101.0022>
32. Jarvis S. H. (2021), <https://doi.org/10.13140/rg.2.2.31751.21925/5>,
<https://www.researchgate.net/publication/348729069> Temporal Mechanics B Time-Space Constants,
<https://vixra.org/abs/2101.0148>
33. Jarvis S. H. (2021), <https://doi.org/10.13140/rg.2.2.30214.70720/5>,
<https://www.researchgate.net/publication/349108810> Temporal Mechanics C Time-Space Manifolds,
<https://vixra.org/abs/2102.0047>
34. Jarvis S. H. (2021), <https://doi.org/10.13140/rg.2.2.17868.54403/5>,
<https://www.researchgate.net/publication/350090036> Temporal Mechanics D Time-Space Metrics,
<https://vixra.org/abs/2103.0102>

35. Jarvis S. H. (2021), <https://doi.org/10.13140/rg.2.2.28496.84483/7>,
https://www.researchgate.net/publication/350512305_Temporal_Mechanics_E_Time-Space_Logistics,
<https://vixra.org/abs/2103.0201>
36. Jarvis S. H. (2021), <https://doi.org/10.13140/rg.2.2.34363.34082/5>,
https://www.researchgate.net/publication/353224312_Quantum_Gravity_and_the_calculation_of_maximum_SOL_mass, <https://vixra.org/abs/2107.0086>
37. Jarvis S. H. (2021), <https://doi.org/10.13140/rg.2.2.20022.42563/5>,
https://www.researchgate.net/publication/353403592_An_Axiom_of_Time_resolving_Entropy_CP_violation_and_the_isotropic_CMBR, <https://vixra.org/abs/2107.0146>
38. Jarvis S. H. (2021), <https://doi.org/10.13140/rg.2.2.28179.20007/6>,
https://www.researchgate.net/publication/354794575_Temporal_Mechanics_and_EM-DIR_particle_pair_production, <https://vixra.org/abs/2109.0167>
39. Jarvis S. H. (2021), <https://doi.org/10.13140/rg.2.2.15658.13764/4>,
https://www.researchgate.net/publication/356039421_Temporal_Mechanics_and_the_derivation_of_an_electron_degeneracy_neutrino_Gravity_constant_G_fine_structure_constant_a_Planck_constant_h_and_the_phenomenal_values_of_Sol, <https://vixra.org/abs/2111.0045>
40. Jarvis S. H. (2021), <http://dx.doi.org/10.13140/RG.2.2.19674.67529/6>,
https://www.researchgate.net/publication/356508902_Time_domains_as_the_foundation_for_classical_mechanics_the_relativity_of_moving_objects_and_the_known_field_forces_presenting_the_case_for_a_unified_field_theory, <https://vixra.org/abs/2111.0131>
41. Jarvis S. H. (2022), [10.13140/RG.2.2.17398.93763/6](https://doi.org/10.13140/RG.2.2.17398.93763/6),
https://www.researchgate.net/publication/357690054_A_time_equation_thought_experiment_deriving_3D_space_as_timespace_in_forming_the_basis_for_particle_and_field_phenomena, <https://vixra.org/abs/2201.0043>
42. Jarvis S. H. (2022), [10.13140/RG.2.2.23272.75521/5](https://doi.org/10.13140/RG.2.2.23272.75521/5),
https://www.researchgate.net/publication/358974090_The_Temporal_Mechanics_XEMDIR_field_resolving_zero-point_energy_negative_energy_anti-EM_anti-gravity_symmetry_breaking_and_Baryon_asymmetry,
<https://vixra.org/abs/2203.0018>
43. Jarvis S. H. (2022), <https://doi.org/10.13140/rg.2.2.23915.00808/4>,
https://www.researchgate.net/publication/359052099_The_mathematics_of_zero-dimensional_space,
<https://vixra.org/abs/2203.0030>
44. Jarvis S. H. (2022), <https://doi.org/10.13140/rg.2.2.33528.32000/6>,
https://www.researchgate.net/publication/359577367_A_mathematical_analysis_of_zero-dimensionality_in_deriving_the_natural_numbers_offering_a_solution_to_Goldbach's_conjecture_and_the_Riemann_hypothesis, <https://vixra.org/abs/2203.0181>
45. Jarvis S. H. (2022), <http://dx.doi.org/10.13140/RG.2.2.24087.85921/3>,
https://www.researchgate.net/publication/360065326_A_foundational_zero-dimensional_scaling_system_mandating_the_principle_of_relativity_and_the_associated_constancy_of_the_speed_of_light_in_a_vacuum, <https://vixra.org/abs/2204.0127>
46. Jarvis S. H. (2022), <http://dx.doi.org/10.13140/RG.2.2.11064.21768/2>,
https://www.researchgate.net/publication/360270193_The_flaw_of_applying_mathematics_directly_to_physical_phenomena_in_addressing_the_Entscheidungsproblem_and_Godel's_theorems_as_compared_to_the_mathematics_of_zero-dimensionality, <https://vixra.org/abs/2204.0177>

47. Jarvis S. H. (2022), [10.13140/RG.2.2.23165.44001/3](https://www.researchgate.net/publication/360588347), <https://www.researchgate.net/publication/360588347> Zero-dimensional mathematics and the associated timespace Xemdir field geodesic in deriving Fermat's principle the stationary-action principle and the principle of inertia, <https://vixra.org/abs/2205.0079>
48. Jarvis S. H. (2022), [10.13140/RG.2.2.29238.57929/5](https://www.researchgate.net/publication/361556863), <https://www.researchgate.net/publication/361556863> Zero-dimensional philosophy, <https://vixra.org/abs/2207.0135>.
49. Jarvis S. H. (2022), <https://www.researchgate.net/publication/361864787> Zero-dimensional number theory, [10.13140/RG.2.2.22499.84008/4](https://www.researchgate.net/publication/361864787).
50. Jarvis S. H. (2022), [10.13140/RG.2.2.14200.52480/2](https://www.researchgate.net/publication/363474597), <https://www.researchgate.net/publication/363474597> The zero-dimensional physical theory I solving reality's puzzle, <https://vixra.org/abs/2209.0125>.
51. Jarvis S. H. (2022), <http://dx.doi.org/10.13140/RG.2.2.16815.41127/4>, <https://www.researchgate.net/publication/363799929> The zero-dimensional physical theory II causality locality and indeterminacy, <https://vixra.org/abs/2209.0150>.
52. Jarvis S. H. (2022), <http://dx.doi.org/10.13140/RG.2.2.11854.95049/2>, <https://www.researchgate.net/publication/364223266> The zero-dimensional physical theory III graphing time and space <https://vixra.org/abs/2210.0031>.
53. Jarvis S. H. (2022), <http://dx.doi.org/10.13140/RG.2.2.34844.97926/3>, <https://www.researchgate.net/publication/364274254> The zero-dimensional physical theory IV zero-point field dynamics <https://vixra.org/abs/2210.0033>
54. Jarvis S. H. (2022), <http://dx.doi.org/10.13140/RG.2.2.10198.52802>, <https://www.researchgate.net/publication/364872351> The zero-dimensional physical theory V information energy efficiency and intelligence, <https://vixra.org/abs/2210.0160>
55. Jarvis S. H. (2022), [10.13140/RG.2.2.25257.88162/3](https://www.researchgate.net/publication/365632392), <https://www.researchgate.net/publication/365632392> The zero-dimensional physical theory VI charting the Clay Mathematics Institute Millennium Prize problems a nd Beal conjecture, <https://vixra.org/abs/2211.0133>
56. Jarvis S. H. (2023), <http://dx.doi.org/10.13140/RG.2.2.32104.75527/4>, <https://www.researchgate.net/publication/366781077> The zero-dimensional physical theory VII charting infinity using the Riemann zeta function and Ramanujan summation in deriving dimensional number paradigms, <https://vixra.org/abs/2301.0014>
57. https://en.wikipedia.org/wiki/Lambda-CDM_model, webpage accessed May 15th, 2023.
58. https://en.wikipedia.org/wiki/Quantum_field_theory, webpage accessed May 15th, 2023.
59. Peskin, M.; Schroeder, D. (1995). *An Introduction to Quantum Field Theory*. Westview Press. ISBN 978-0-201-50397-5.
60. https://en.wikipedia.org/wiki/General_relativity, webpage accessed May 15th, 2023.
61. Albert Einstein (2011). *Relativity – The Special and General Theory*. Read Books Ltd. p. 4. ISBN 978-1-4474-9358-7.
62. <https://www.claymath.org/millennium-problems>, webpage accessed May 15th, 2023.
63. https://en.wikipedia.org/wiki/List_of_physics_journals, webpage accessed 17th May 2023.
64. <https://www.scientificamerican.com/article/is-time-travel-possible/>, webpage accessed May 15th, 2023.
65. <https://en.wikipedia.org/wiki/Calculus>, webpage accessed May 15th, 2023.

66. <http://www.britannica.com/EBchecked/topic/369153/The-Mathematical-Principles-of-Natural-Philosophy>, webpage accessed May 15th, 2023.
67. Newton, Isaac (1846), Newton's Principia : the mathematical principles of natural philosophy, New York: Daniel Adee, p. 72, page accessed 9th June 2019
68. https://en.wikipedia.org/wiki/Quantum_gravity, webpage accessed May 15th, 2023.
69. <https://www.sciencedirect.com/topics/physics-and-astronomy/quantum-gravity>, webpage accessed May 15th, 2023.
70. Aristotle. trans. by R. P. Hardie and R. K. Gaye (ed.). "Physics". The Internet Classics Archive. II 9.
71. <http://classics.mit.edu/Plato/parmenides.html>, webpage accessed 26th June 2023.
72. <https://www.scientificamerican.com/article/quantum-gravity-in-the-lab/>, webpage accessed May 15th, 2023.
73. <https://www.scientificamerican.com/article/how-the-inside-of-a-black-hole-is-secretly-on-the-outside/>, webpage accessed May 15th, 2023.
74. <https://www.msn.com/en-au/news/techandscience/scientists-say-they-ve-finally-solved-stephen-hawking-s-black-hole-paradox/ar-AA1aMUv5?ocid=msedgntp&cvid=b918196e77c5405eb1410938652e3669&ei=9>, webpage accessed May 15th, 2023.
75. <https://www.scientificamerican.com/article/a-background-hum-pervades-the-universe-scientists-are-racing-to-find-its-source/>, webpage accessed October 1st, 2023.
76. <https://iopscience.iop.org/article/10.3847/2041-8213/abd401/meta>, webpage accessed October 1st, 2023.