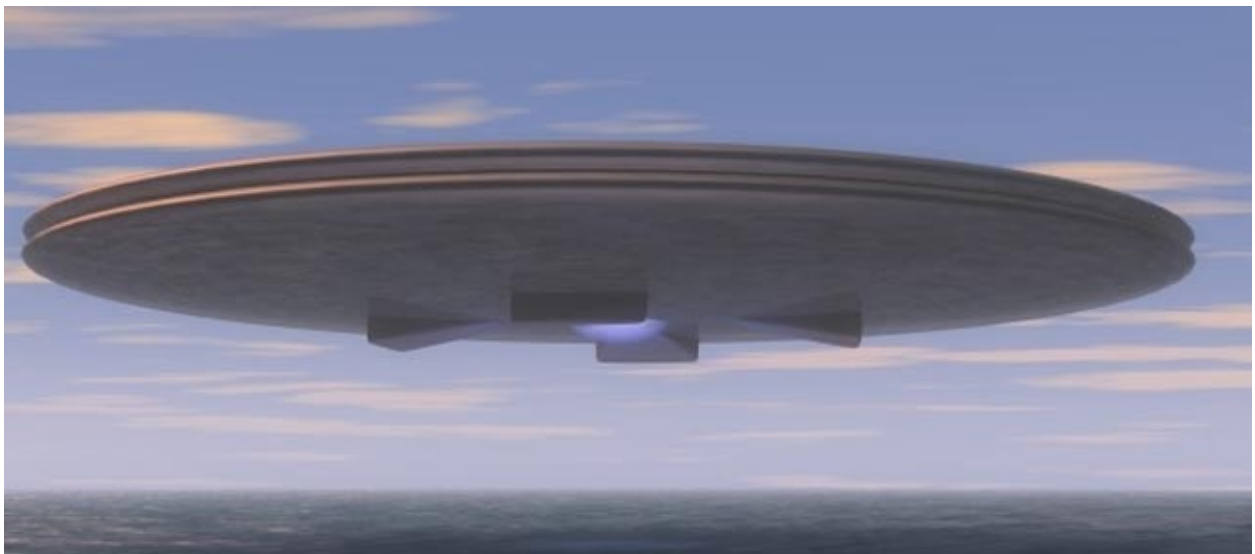


THE WORLD'S FUTURE

# Femtotechnologies and Innovative Projects (v.2)

By Alexander Bolonkin



USA, Lulu 2011

**Title Femtotechnologies and Innovative Projects (v.2)**

Author: Alexander Bolonkin

ISBN 978-1-300-48671-8

New macro-projects, concepts, ideas, methods, and innovations are explored here, but hardly developed. There remain many problems that must be researched, modeled, and tested before these summarized research ideas can be practically designed, built, and utilized—that is, fully developed and utilized.

Most ideas in our book are described in the following way: 1) Description of current state in a given field of endeavor. A brief explanation of the idea researched, including its advantages and short comings; 2) Then methods, estimation and computations of the main system parameters are listed, and 3) A brief description of possible applications—candidate macro-projects, including estimations of the main physical parameters of such economic developmental undertakings.

The first and third parts are in a popular form accessible to the wider reading public, the second part of this book will require some mathematical and scientific knowledge, such as may be found amongst technical school graduate students.

The book gives the main physical data and technical equations in attachments which will help researchers, engineers, dedicated students and enthusiastic readers make estimations for their own macro-projects. Also, inventors will find an extensive field of inventions and innovations revealed in our book.

The author have published many new ideas and articles and proposed macro-projects in recent years (see: General References). This book is useful as an archive of material from the authors' own articles published during the last few years.

Every chapter is independent. Than why some figures are repited.

Copyright @ author.

Publisher: LULU, [www.lulu.com](http://www.lulu.com).

## Contents

About Author

Abstract

Preface

Chapters:

### **Part A. New Technology.**

- |   |     |
|---|-----|
| 1. Conversion of any Matter into Energy by AB-Generator and Photon Rocket.                                  | 8   |
| 2. Femtotechnology: superstrong AB-Material with Fantastic Properties and its Applications.                 | 24  |
| 3. Femtotechnology. AB-needles: Stability, Possible Production and Application.                             | 47  |
| 4. Space Wing Electro Relativistic AB-Ship.   | 63  |
| 5. Wireless Transfer of Electricity to Long Distance.   | 75  |
| 6. AB-Blanket for Cities  | 90  |
| 7. Live Humans in Outer Space without Space Suit.   | 113 |
| 8. Magnetic Space Launchers   | 122 |
| 9. Low currency Railgun.  | 133 |
| 10. Superconductivity Hypersonic Accelerator  | 147 |
| 11. Magnetic Suspended AB-Structures and Motionless Satellites and Space Stations                           | 165 |
| 12. Explosion of Sun. AB-Criterion of Solar Detonation.   | 184 |
| 13. Review of Space Towers  | 204 |
| 14. Review of new ideas, innovations of non-rocket propulsion systems for Space Launch and Flight (Part 1). | 218 |
| 15. Review of new ideas, innovations of non-rocket propulsion systems for Space Launch and Flight (Part 2). | 251 |
| 16. Review of new ideas, innovations of non-rocket propulsion systems for Space Launch and Flight (Part 3). | 316 |

### **Part B. Projects solvable by current technology**

- |  |     |
|--|-----|
| 1. Aerial Gas Pipelines.   | 367 |
| 2. Production Fresh Water from Exhaust Gas.                            | 385 |
| 3. Sea Solar Distiller.  | 292 |
| 4. High Altitude Aerial Antenna  | 404 |
| 5. Suppression of Forest Fire without Water                            | 414 |
| 6. Wind AB-Wall.   | 425 |
| 7. Natural Purpose of Mankind is to become a God.                      | 455 |
| 8. Robot as Person. Personhood. Three Prerequisites or Laws of Robots. | 466 |

### **Part C. Problems of Technical Progress**

- |  |     |
|--|-----|
| 1. Science Research and Technical Progress | 471 |
|--|-----|

#### *Appendixes:*

- |   |     |
|---|-----|
| 1. System of Mechanical, Magnetic Electric Units.                               | 484 |
| 2. Data useful for estimation and calculation of new technologies and projects. | 491 |
| 3. General References   | 499 |

## **ABOUT THE AUTHOR**

### **Bolonkin, Alexander Alexandrovich (1933- )**

Alexander A. Bolonkin was born in the former USSR. He holds doctoral degree in aviation engineering from Moscow Aviation Institute and a post-doctoral degree in aerospace engineering from Leningrad Polytechnic University. He has held the positions of senior engineer in the Antonov Aircraft Design Company and Chairman of the Reliability Department in the Clushko Rocket Design Company. He has also lectured at the Moscow Aviation Universities. Following his arrival in the United States in 1988, he lectured at the New Jersey Institute of Technology and worked as a Senior Researcher at NASA and the US Air Force Research Laboratories.

Bolonkin is the author of more than 180 scientific articles and books and has 17 inventions to his credit. His most notable books include *The Development of Soviet Rocket Engines* (Delphic Ass., Inc., Washington , 1991); *Non-Rocket Space Launch and Flight* (Elsevier, 2006); *New Concepts, Ideas, Innovation in Aerospace, Technology and Human Life* (NOVA, 2007); *Macro-Projects: Environment and Technology* (NOVA, 2008); *Human Immortality and Electronic Civilization*, 3-rd Edition, (Lulu, 2007; Publish America, 2010).





## **Abstract**

In recent years of the 21<sup>st</sup> Century the author of this book and other scientists as well, have instigated and described many new ideas, researches, theories, macro-projects, USA and other countries patented concepts, speculative macro-engineering ideas, projects and other general innovations in technology and environment change. These all hold the enticing promise for a true revolution in the lives of humans everywhere in the Solar System.

Here, the author includes and reviews new methods for converting of any matter into energy, getting of super strong materials, for travel in outer space without space suit, magnetic space launchers, magnetic space towers, motionless satellites and suspended structures, comfortable permanent settlements for cities and Earth's hazardous polar regions, control of local and global weather conditions, wireless transfer of electricity to long distance, Magnetic guns, magnetic launchers, new (magnetic, electrostatic, electronic gas) space towers, space elevators and space climbers, suppression forest fires without water, aerial gas pipelines, production of fresh water from sea water, thermonuclear reactors, along with many others.

Author succinctly summarizes some of these revolutionary macro-projects, concepts, ideas, innovations, and methods for scientists, engineers, technical students, and the world public. Every Chapter has three main sections: At first section the author describes the new idea in an easily comprehensible way acceptable for the general public (no equations), the second section contains the scientific proof of the innovation acceptable for technical students, engineers and scientists, and the third section contains the applications of innovation.

Author does seek future attention from the general public, other macro-engineers, inventors, as well as scientists of all persuasions for these presented innovations. And, naturally, he fervently hopes the popular news media, various governments and the large international aerospace and other engineering-focused corporations will, as well, increase their respective observation, R&D activity in the technologies for living and the surrounding human environment.

## PREFACE

New macro-projects, concepts, ideas, methods, and innovations are explored here, but hardly developed. There remain many problems that must be researched, modeled, and tested before these summarized research ideas can be practically designed, built, and utilized—that is, fully developed and utilized.

Most ideas in our book are described in the following way: 1) Description of current state in a given field of endeavor. A brief explanation of the idea researched, including its advantages and short comings; 2) Then methods, estimation and computations of the main system parameters are listed, and 3) A brief description of possible applications—candidate macro-projects, including estimations of the main physical parameters of such economic developmental undertakings.

The first and third parts are in a popular form accessible to the wider reading public, the second part of this book will require some mathematical and scientific knowledge, such as may be found amongst technical school graduate students.

The book gives the main physical data and technical equations in attachments which will help researchers, engineers, dedicated students and enthusiastic readers make estimations for their own macro-projects. Also, inventors will find an extensive field of inventions and innovations revealed in our book.

The author have published many new ideas and articles and proposed macro-projects in recent years (see: General References). This book is useful as an archive of material from the authors' own articles published during the last few years.

Every chapter is independent. Than why some figures are repited.

### Acknowledgement

1. Some data in this work is garnered from Wikipedia under the Creative Commons License.
2. The author wish to acknowledge Joseph Friedlander for help in editing of this book.

## **PART A. NEW TECHNOLOGY**

## Chapter 1

# Converting of Matter to Nuclear Energy by AB-Generator\* and Photon Rocket

### Abstract

Author offers a new nuclear generator which allows to convert any matter to nuclear energy in accordance with the Einstein equation  $E=mc^2$ . The method is based upon tapping the energy potential of a Micro Black Hole (MBH) and the Hawking radiation created by this MBH. As is well-known, the vacuum continuously produces virtual pairs of particles and antiparticles, in particular, the photons and anti-photons. The MBH event horizon allows separating them. Anti-photons can be moved to the MBH and be annihilated; decreasing the mass of the MBH, the resulting photons leave the MBH neighborhood as Hawking radiation. The offered nuclear generator (named by author as AB-Generator) utilizes the Hawking radiation and injects the matter into MBH and keeps MBH in a stable state with near-constant mass.

The AB-Generator can produce gigantic energy outputs and should be cheaper than a conventional electric station by a factor of hundreds of times. One also may be used in aerospace as a photon rocket or as a power source for many vehicles.

Many scientists expect the Large Hadron Collider at CERN will produce one MBH every second. A technology to capture them may follow; than they may be used for the AB-Generator.

-----

**Key words:** Production of nuclear energy, Micro Black Hole, energy AB-Generator, photon rocket.

\* Presented as Paper AIAA-2009-5342 in 45 Joint Propulsion Conferences, 2–5 August, 2009, Denver, CO, USA.

### Introduction

**Black hole.** In general relativity, a black hole is a region of space in which the gravitational field is so powerful that nothing, including light, can escape its pull. The black hole has a one-way surface, called the event horizon, into which objects can fall, but out of which nothing can come out. It is called "black" because it absorbs all the light that hits it, reflecting nothing, just like a perfect blackbody in thermodynamics.

Despite its invisible interior, a black hole can reveal its presence through interaction with other matter. A black hole can be inferred by tracking the movement of a group of stars that orbit a region in space which looks empty. Alternatively, one can see gas falling into a relatively small black hole, from a companion star. This gas spirals inward, heating up to very high temperature and emitting large amounts of radiation that can be detected from earthbound and earth-orbiting telescopes. Such observations have resulted in the general scientific consensus that, barring a breakdown in our understanding of nature, black holes do exist in our universe.

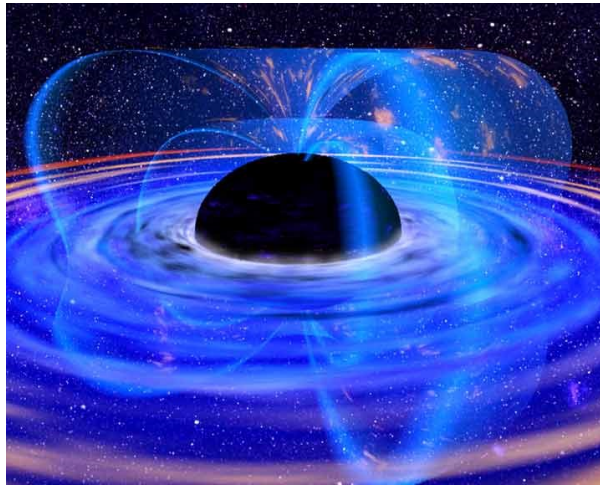
It is impossible to directly observe a black hole. However, it is possible to infer its presence by its gravitational action on the surrounding environment, particularly with microquasars and active galactic nuclei, where material falling into a nearby black hole is significantly heated and emits a large amount of X-ray radiation. This observation method allows astronomers to detect their existence. The only objects that agree with these observations and are consistent within the framework of general relativity are black holes.

A black hole has only three independent physical properties: mass, charge and angular momentum.

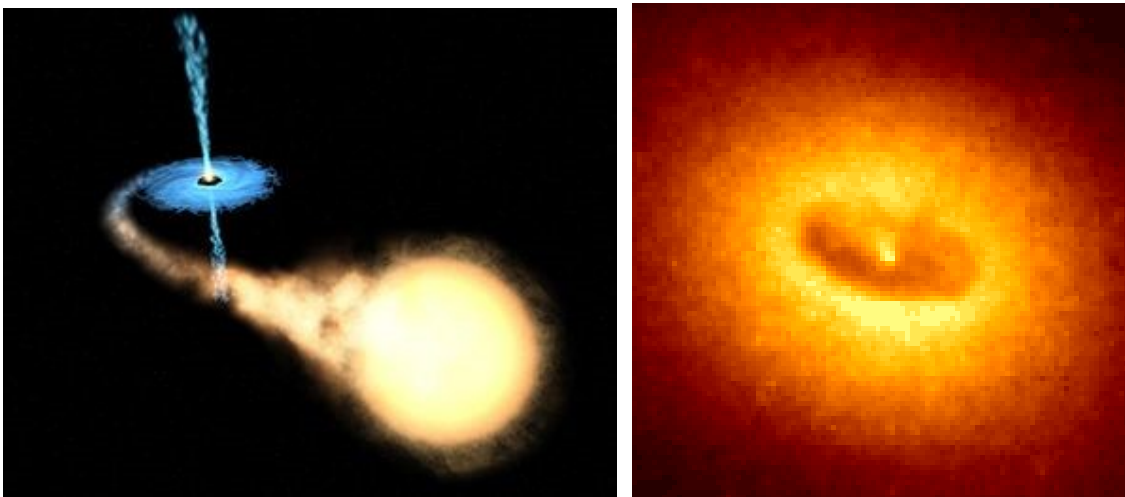
In astronomy black holes are classed as:

- Supermassive - contain hundreds of thousands to billions of solar masses and are thought to exist in the center of most galaxies, including the Milky Way.
- Intermediate - contain thousands of solar masses.
- Micro (also *mini black holes*) - have masses much less than that of a star. At these sizes, quantum mechanics is expected to take effect. There is no known mechanism for them to form via normal processes of stellar evolution, but certain inflationary scenarios predict their production during the early stages of the evolution of the universe.

According to some theories of quantum gravity they may also be produced in the highly energetic reaction produced by cosmic rays hitting the atmosphere or even in particle accelerators such as the Large Hadron Collider. The theory of Hawking radiation predicts that such black holes will evaporate in bright flashes of gamma radiation. NASA's Fermi Gamma-ray Space Telescope (formerly GLAST) launched in 2008 is searching for such flashes.



**Fig 1.** Artist's conception of a stellar mass black hole. Credit NASA.



**Fig.2** (left). Artist's impression of a binary system consisting of a black hole and a main sequence star. The black hole is drawing matter from the main sequence star via an accretion disk around it, and some of this matter

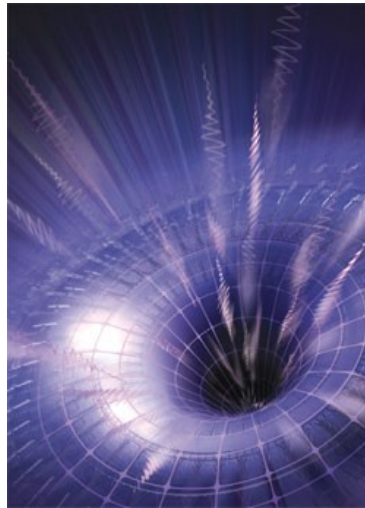
forms a gas jet.

**Fig.3** (right). Ring around a suspected black hole in galaxy NGC 4261. Date: Nov.1992. Courtesy of Space Telescope Science

The defining feature of a black hole is the appearance of an *event horizon*; a boundary in spacetime beyond which events cannot affect an outside observer.

Since the event horizon is not a material surface but rather merely a mathematically defined demarcation boundary, nothing prevents matter or radiation from entering a black hole, only from exiting one.

For a non rotating (static) black hole, the *Schwarzschild radius* delimits a spherical event horizon. The Schwarzschild radius of an object is proportional to the mass. Rotating black holes have distorted, nonspherical event horizons. The description of black holes given by general relativity is known to be an approximation, and it is expected that quantum gravity effects become significant near the vicinity of the event horizon. This allows observations of matter in the vicinity of a black hole's event horizon to be used to indirectly study general relativity and proposed extensions to it.



**Fig.4.** Artist's rendering showing the space-time contours around a black hole. Credit NASA.

Though black holes themselves may not radiate energy, electromagnetic radiation and matter particles may be radiated from just outside the event horizon via *Hawking radiation*.

At the center of a black hole lies the *singularity*, where matter is crushed to infinite density, the pull of gravity is infinitely strong, and spacetime has infinite curvature. This means that a black hole's mass becomes entirely compressed into a region with zero volume. This zero-volume, infinitely dense region at the center of a black hole is called a *gravitational singularity*.

The singularity of a non-rotating black hole has zero length, width, and height; a rotating black hole's is smeared out to form a ring shape lying in the plane of rotation. The ring still has no thickness and hence no volume.

The *photon sphere* is a spherical boundary of zero thickness such that photons moving along tangents to the sphere will be trapped in a circular orbit. For non-rotating black holes, the photon sphere has a radius 1.5 times the Schwarzschild radius. The orbits are dynamically unstable, hence any small perturbation (such as a particle of infalling matter) will grow over time, either setting it on an outward trajectory escaping the black hole or on an inward spiral eventually crossing the event horizon.

Rotating black holes are surrounded by a region of spacetime in which it is impossible to stand still,

called the *ergosphere*. Objects and radiation (including light) can stay in orbit within the ergosphere without falling to the center.

Once a black hole has formed, it can continue to grow by absorbing additional matter. Any black hole will continually absorb interstellar dust from its direct surroundings and omnipresent cosmic background radiation.

Much larger contributions can be obtained when a black hole merges with other stars or compact objects.

**Hawking radiation.** In 1974, Stephen Hawking showed that black holes are not entirely black but emit small amounts of thermal radiation.<sup>[1]</sup> He got this result by applying quantum field theory in a static black hole background. The result of his calculations is that a black hole should emit particles in a perfect black body spectrum. This effect has become known as Hawking radiation. Since Hawking's result many others have verified the effect through various methods. If his theory of black hole radiation is correct then black holes are expected to emit a thermal spectrum of radiation, and thereby lose mass, because according to the theory of relativity mass is just highly condensed energy ( $E = mc^2$ ). Black holes will shrink and evaporate over time. The temperature of this spectrum (Hawking temperature) is proportional to the surface gravity of the black hole, which in turn is inversely proportional to the mass. Large black holes, therefore, emit less radiation than small black holes.

On the other hand if a black hole is very small, the radiation effects are expected to become very strong. Even a black hole that is heavy compared to a human would evaporate in an instant. A black hole the weight of a car ( $\sim 10^4$  kg) would only take a nanosecond to evaporate, during which time it would briefly have a luminosity more than 200 times that of the sun. Lighter black holes are expected to evaporate even faster, for example a black hole of mass 1 TeV/ $c^2$  would take less than  $10^{-88}$  seconds to evaporate completely. Of course, for such a small black hole quantum gravitation effects are expected to play an important role and could even – although current developments in quantum gravity do not indicate so – hypothetically make such a small black hole stable.

**Micro Black Holes.** Gravitational collapse is not the only process that could create black holes. In principle, black holes could also be created in high energy collisions that create sufficient density. Since classically black holes can take any mass, one would expect micro black holes to be created in any such process no matter how low the energy. However, to date, no such events have ever been detected either directly or indirectly as a deficiency of the mass balance in particle accelerator experiments. This suggests that there must be a lower limit for the mass of black holes.

Theoretically this boundary is expected to lie around the Planck mass ( $\sim 10^{19}$  GeV/ $c^2$ ,  $m_p = 2.1764 \cdot 10^{-8}$  kg), where quantum effects are expected to make the theory of general relativity break down completely. This would put the creation of black holes firmly out of reach of any high energy process occurring on or near the Earth. Certain developments in quantum gravity however suggest that this bound could be much lower. Some braneworld scenarios for example put the Planck mass much lower, maybe even as low as 1 TeV. This would make it possible for micro black holes to be created in the high energy collisions occurring when cosmic rays hit the Earth's atmosphere, or possibly in the new Large Hadron Collider at CERN. These theories are however very speculative, and the creation of black holes in these processes is deemed unlikely by many specialists.

**Smallest possible black hole.** To make a black hole one must concentrate mass or energy sufficiently that the escape velocity from the region in which it is concentrated exceeds the speed of light. This condition gives the Schwarzschild radius,  $r_o = 2GM / c^2$ , where  $G$  is Newton's constant and  $c$  is the speed of light, as the size of a black hole of mass  $M$ . On the other hand, the Compton wavelength,  $\lambda = h / Mc$ , where  $h$  is Planck's constant, represents a limit on the minimum size of the



region in which a mass  $M$  at rest can be localized. For sufficiently small  $M$ , the Compton wavelength exceeds the Schwarzschild radius, and no black hole description exists. This smallest mass for a black hole is thus approximately the Planck mass, which is about  $2 \times 10^{-8}$  kg or  $1.2 \times 10^{19}$  GeV/ $c^2$ .

Any primordial black holes of sufficiently low mass will Hawking evaporate to near the Planck mass within the lifetime of the universe. In this process, these small black holes radiate away matter. A rough picture of this is that pairs of virtual particles emerge from the vacuum near the event horizon, with one member of a pair being captured, and the other escaping the vicinity of the black hole. The net result is the black hole loses mass (due to conservation of energy). According to the formulae of black hole thermodynamics, the more the black hole loses mass the hotter it becomes, and the faster it evaporates, until it approaches the Planck mass. At this stage a black hole would have a Hawking temperature of  $T_P / 8\pi$  ( $5.6 \times 10^{32}$  K), which means an emitted Hawking particle would have an energy comparable to the mass of the black hole. Thus a thermodynamic description breaks down. Such a mini-black hole would also have an entropy of only  $4\pi$  nats, approximately the minimum possible value.

At this point then, the object can no longer be described as a classical black hole, and Hawking's calculations also break down. Conjectures for the final fate of the black hole include total evaporation and production of a Planck mass-sized *black hole remnant*. If intuitions about quantum black holes are correct, then close to the Planck mass the number of possible quantum states of the black hole is expected to become so few and so quantised that its interactions are likely to be quenched out. It is possible that such Planck-mass black holes, no longer able either to absorb energy gravitationally like a classical black hole because of the quantised gaps between their allowed energy levels, nor to emit Hawking particles for the same reason, may in effect be stable objects. They would in effect be WIMPs, weakly interacting massive particles; this could explain dark matter.

**Creation of micro black holes.** Production of a black hole requires concentration of mass or energy within the corresponding Schwarzschild radius. In familiar three-dimensional gravity, the minimum such energy is  $10^{19}$  GeV, which would have to be condensed into a region of approximate size  $10^{-33}$  cm. This is far beyond the limits of any current technology; the Large hadron collider (LHC) has a design energy of 14 TeV. This is also beyond the range of known collisions of cosmic rays with Earth's atmosphere, which reach center of mass energies in the range of hundreds of TeV. It is estimated that to collide two particles to within a distance of a Planck length with currently achievable magnetic field strengths would require a ring accelerator about 1000 light years in diameter to keep the particles on track.

Some extensions of present physics posit the existence of extra dimensions of space. In higher-dimensional spacetime, the strength of gravity increases more rapidly with decreasing distance than in three dimensions. With certain special configurations of the extra dimensions, this effect can lower the Planck scale to the TeV range. Examples of such extensions include large extra dimensions, special cases of the Randall-Sundrum model, and String theory configurations. In such scenarios, black hole production could possibly be an important and observable effect at the LHC.

**Virtual particles.** In physics, a virtual particle is a particle that exists for a limited time and space, introducing uncertainty in their energy and momentum due to the Heisenberg Uncertainty Principle.

Vacuum energy can also be thought of in terms of virtual particles (also known as vacuum fluctuations) which are created and destroyed out of the vacuum. These particles are always created out of the vacuum in particle-antiparticle pairs, which shortly annihilate each other and disappear. However, these particles and antiparticles may interact with others before disappearing.

The net energy of the Universe remains zero so long as the particle pairs annihilate each other within Planck time.

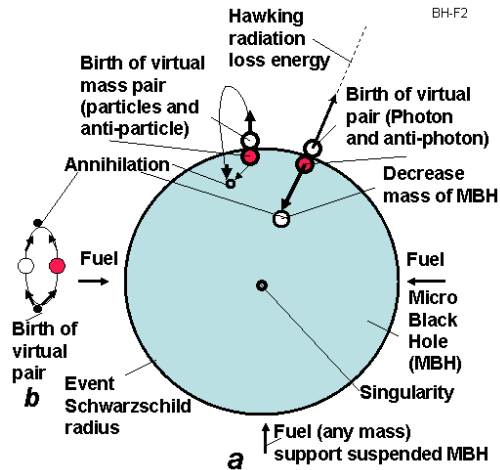
Virtual particles are also excitations of the underlying fields, but are detectable only as forces.

The creation of these virtual particles near the event horizon of a black hole has been hypothesized by physicist Stephen Hawking to be a mechanism for the eventual "evaporation" of black holes.

Since these particles do not have a permanent existence, they are called *virtual particles* or vacuum fluctuations of vacuum energy.

An important example of the "presence" of virtual particles in a vacuum is the [Casimir effect](#). Here, the explanation of the effect requires that the total energy of all of the virtual particles in a vacuum can be added together. Thus, although the virtual particles themselves are not directly observable in the laboratory, they do leave an observable effect: their zero-point energy results in forces acting on suitably arranged metal plates or dielectrics.

Thus, virtual particles are often popularly described as coming in pairs, a particle and antiparticle, which can be of any kind.



**Fig.5.** Hawking radiation. *a.* Virtual particles at even horizon.  
*b.* Virtual particles out even horizon (in conventional space).

The evaporation of a black hole is a process dominated by photons, which are their own antiparticles and are uncharged.

The uncertainty principle in the form  $\Delta E \Delta t \geq \hbar$  implies that in the vacuum one or more particles with energy  $\Delta E$  above the vacuum may be created for a short time  $\Delta t$ . These *virtual particles* are included in the definition of the vacuum.

**Vacuum energy** is an underlying background energy that exists in space even when devoid of matter (known as free space). The vacuum energy is deduced from the concept of virtual particles, which are themselves derived from the energy-time uncertainty principle. Its effects can be observed in various phenomena (such as spontaneous emission, the Casimir effect, the van der Waals bonds, or the Lamb shift), and it is thought to have consequences for the behavior of the Universe on cosmological scales.

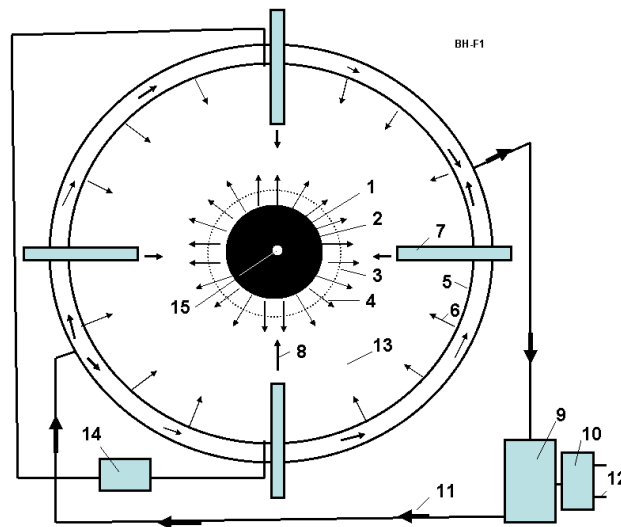
## AB-Generator of Nuclear Energy and some Innovations

**Simplified explanation of MBH radiation and work of AB-Generator (Fig.5).** As known, the vacuum continuously produces, virtual pairs of particles and antiparticles, in particular, photons and anti-photons. In conventional space they exist only for a very short time, then annihilate and return back to nothingness. The MBH event horizon, having very strong super-gravity, allows separation of the particles and anti particles, in particular, photons and anti-photons. Part of the anti-photons move into the MBH and annihilate with photons decreasing the mass of the MBH and return back a borrow

energy to vacuum. The free photons leave from the MBH neighborhood as Hawking radiation. That way the MBH converts any conventional matter to Hawking radiation which may be converted to heat or electric energy by the AB- Generator. This AB- Generator utilizes the produced Hawking radiation and injects the matter into the MBH while maintaining the MBH in stable suspended state.

**Note:** The photon does NOT have rest mass. Therefore a photon can leave the MBH's neighborhood (if it is located beyond the event horizon). All other particles having a rest mass and speed less than light speed *cannot* leave the Black Hole. They cannot achieve light speed because their mass at light speed equals infinity and requests infinite energy for its' escape—an impossibility.

**Description of AB- Generator.** The offered nuclear energy AB- Generator is shown in fig. 6. That includes the Micro Black Hole (MBH) 1 suspended within a spherical radiation reflector and heater 5. The MBH is supported (and controlled) at the center of sphere by a fuel (plasma, proton, electron, matter) gun 7. This AB- Generator also contains the 9 – heat engine (for example, gas, vapor turbine), 10 – electric generator, 11 – coolant (heat transfer agent), an outer electric line 12, internal electric generator (5 as antenna) with customer 14.



**Fig.6.** Offered nuclear-vacuum energy AB- Generator. Notations: 1- Micro Black Hole (MBH), 2 - event horizon (Schwarzschild radius), 3 - photon sphere, 4 – black hole radiation, 5 – radiation reflector, antenna and heater (cover sphere), 6 – back (reflected) radiation from radiation reflector 5, 7 – fuel (plasma, protons, electrons, ions, matter) gun (focusing accelerator), 8 – matter injected to MBH (fuel for Micro Black hole), 9 – heat engine (for example, gas, vapor turbine), 10 – electric generator connected to heat engine 9, 11 – coolant (heat transfer agent to the heat machine 9), 12 – electric line, 13 – internal vacuum, 14 – customer of electricity from antenna 5, 15 – singularity.

**Work.** The generator works the following way. MBH, by selective directional input of matter, is levitated in captivity and produces radiation energy 4. That radiation heats the spherical reflector-heater 5. The coolant (heat transfer agent) 11 delivers the heat to a heat machine 9 (for example, gas, vapor turbine). The heat machine rotates an electric generator 10 that produces the electricity to the outer electric line 12. Part of MBH radiation may accept by sphere 5 (as antenna) in form of electricity.

The control fuel guns inject the matter into MBH and do not allow bursting of the MBH. This action also supports the MBH in isolation, suspended from dangerous contact with conventional matter. They also control the MBH size and the energy output.

Any matter may be used as the fuel, for example, accelerated plasma, ions, protons, electrons, micro particles, etc. The MBH may be charged and rotated. In this case the MBH may has an additional

suspension by control charges located at the ends of fuel guns or (in case of the rotating charged MBH) may have an additional suspension by the control electric magnets located on the ends of fuel guns or at points along the reflector-heater sphere.

### **Innovations, features, advantages and same research results**

Some problems and solutions offered by the author include the following:

- 1) A practical (the MBH being obtained and levitated, details of which are beyond the scope of this paper) method and installation for converting any conventional matter to energy in accordance with Einstein's equation  $E = mc^2$ .
- 2) MBHs may produce gigantic energy and this energy is in the form of dangerous gamma radiation. The author shows how this dangerous gamma radiation Doppler shifts when it moves against the MBH gravity and converts to safely tapped short radio waves.
- 3) The MBH of marginal mass has a tendency to explode (through quantum evaporation, very quickly radiating its mass in energy). The AB- Generator automatically injects metered amounts of matter into the MBH and keeps the MBH in a stable state or grows the MBH to a needed size, or decreases that size, or temporarily turns off the AB- Generator (decreases the MBH to a Planck Black Hole).
- 4) Author shows the radiation flux exposure of AB- Generator (as result of MBH exposure) is not dangerous because the generator cover sphere has a vacuum, and the MBH gravity gradient decreases the radiation energy.
- 5) The MBH may be supported in a levitated (non-contact) state by generator fuel injectors.

### **Theory of AB- Generator**

Below there are main equations for computation the conventional black hole (BH) and AB-Generator.

#### **General theory of Black Hole.**

1. Power produced by BH is

$$P = \frac{\hbar c^6}{15360\pi G^2} \frac{1}{M^2} \approx 3.56 \cdot 10^{32} \frac{1}{M^2}, \quad \text{W}, \quad (1)$$

where  $\hbar = h/2\pi = 1.0546 \cdot 10^{-34} \text{ J/s}$  is reduced Planck constant,  $c = 3 \cdot 10^8 \text{ m/s}$  - light speed,  $G = 6.6743 \cdot 10^{-11} \text{ m}^3/\text{kg}\cdot\text{s}^2$  is gravitation constant,  $M$  – mass of BH, kg.

2. Temperature of black body corresponding to this radiation is

$$T = \frac{\hbar c^3}{8\pi G k_b} \frac{1}{M} \approx 1.23 \cdot 10^{23} \frac{1}{M}, \quad \text{K}, \quad (2)$$

where  $k_b = 1.38 \cdot 10^{-23} \text{ J/k}$  is Boltzmann constant.

3. Energy  $E_p$  [J] and frequency  $\nu_0$  of photon at event horizon are

$$E_p = \frac{\hbar c^3}{16\pi G} \frac{1}{M}, \quad \nu_0 = \frac{E_p}{h} = \frac{c^3}{16\pi G} \frac{1}{M} = 8.037 \cdot 10^{33} \frac{1}{M}, \quad \lambda_0 = \frac{c}{\nu_0} = 3.73 \cdot 10^{-26} M. \quad (3)$$

where  $c = 3 \cdot 10^8 \text{ m/s}$  is light speed,  $\lambda_0$  is wavelength of photon at even radius, m.  $h$  is Planck constant.

4. Radius of BH event horizon (Schwarzschild radius) is

$$r_0 = \frac{2G}{c^2} M = 1.48 \cdot 10^{-27} M, \quad \text{m}, \quad (4)$$

5. Relative density (ratio of mass  $M$  to volume  $V$  of BH) is

$$\rho = \frac{M}{V} = \frac{3c^2}{32\pi G^3} \frac{1}{M^2} \approx 7.33 \cdot 10^{79} \frac{1}{M^2}, \quad \text{kg/m}^3. \quad (5)$$

6. Maximal charge of BH is

$$Q_{\max} = 5 \cdot 10^9 eM \approx 8 \cdot 10^{-10} M, \quad \text{C}, \quad (6)$$

where  $e = -1.6 \cdot 10^{-19}$  is charge of electron, C.

7. Life time of BH is

$$\tau = \frac{5120\pi G^2}{\hbar c^4} M^3 = 2.527 \cdot 10^{-8} M^3, \quad \text{s}. \quad (7)$$

8. Gravitation around BH ( $r$  is distance from center) and on event horizon

$$g = \frac{GM}{r^2}, \quad g_0 = \frac{c^4}{4G} \frac{1}{M} = 3 \cdot 10^{42} \frac{1}{M}, \quad \text{m s}^{-2}. \quad (8)$$

## Developed Theory of AB-Generator

Below are research and the theory developed by author for estimation and computation of facets of the AB- Generator.

**9. Loss of energy of Hawking photon in BH gravitational field.** It is known the theory of a redshift allows estimating the frequency of photon in central gravitational field when it moves TO the gravity center. In this case the photon increases its frequency because photon is accelerated the gravitational field (wavelength decreases). But in our case the photon moves FROM the gravitational center, the gravitational field brakes it and the photon loses its energy. That means its frequency decreases and the wavelength increases. Our photon gets double energy because the black hole annihilates two photons (photon and anti-photon). That way the equation for photon frequency at distance  $r > r_0$  from center we can write in form

$$\frac{\nu}{\nu_0} \approx 1 + \frac{2\Delta\varphi}{c^2}, \quad (9)$$

Where  $\Delta\varphi = \varphi - \varphi_0$  is difference of the gravity potential. The gravity potential is

$$\Delta\varphi = \varphi - \varphi_0, \quad \varphi = \frac{GM}{r}, \quad \varphi_0 = \frac{GM}{r_0}, \quad r_0 = \frac{2GM}{c^2}. \quad (10)$$

Let us substitute (10) in (9), we get

$$\frac{\nu}{\nu_0} \approx 1 + \frac{r_0}{r} - \frac{r_0}{r_0}, \quad \text{or} \quad \frac{\nu}{\nu_0} = \frac{\lambda_0}{\lambda} \approx \frac{r_0}{r}. \quad (11)$$

It is known, the energy and mass of photon is

$$E_f = \hbar\gamma, \quad E_f = m_f c^2, \quad m_f = E_f / c^2, \quad (12)$$

The energy of photon linear depends from its frequency. Reminder: The photon does not have a rest mass.

The relative loss of the photon radiation energy  $\xi$  at distance  $r$  from BH and the power  $P_r$  of Hawking radiation at radius  $r$  from the BH center is

$$\xi = \frac{r_0}{r}, \quad \nu = \xi\nu_0, \quad P_r = \xi P. \quad (13)$$

The  $r_0$  is very small and  $\xi$  is also very small and  $\nu \ll \nu_0$ .

The result of an energy loss by Hawking photon in the BH gravitational field is very important for AB-Generator. The energy of Hawking radiation is very big; we very need to decrease it in many orders. The initial Hawking photon is gamma radiation that is dangerous for people and matter. In  $r$

distance the gamma radiation may be converted in the conventional light or radio radiation, which are not dangerous and may be reflected, focused or a straightforward way converted into electricity by antenna.

**10. Reflection Hawking radiation back to MBH.** For further decreasing the MBH produced energy the part of this energy may be reflected to back in MBH. A conventional mirror may reflect up  $0.9 \div 0.99$  of radiation ( $\xi_r = 0.01 \div 0.1$ ,  $\xi_r$  is a loss of energy in reflecting), the multi layers mirror can reflect up  $0.9999$  of the monochromatic light radiation ( $\xi_r = 10^{-3} \div 10^{-5}$ ), and AB-mirror from cubic corner cells offered by author in [2], p. 226, fig.12.1g, p. 376 allows to reflect non-monochromatic light radiation with efficiency up  $\xi_r = 10^{-13}$  strong back to source. In the last case, the loss of reflected energy is ([2] p.377)

$$\xi_r = 0.00023al, \quad l = m\lambda, \quad m \geq 1, \quad (14)$$

where  $l$  is size of cube corner cell,  $m$ ;  $m$  is number of radiation waves in one sell;  $\lambda$  is wavelength,  $m$ ;  $a$  is characteristic of sell material (see [2], fig.A3.3). Minimal value  $a = 10^{-2}$  for glass and  $a = 10^{-4}$  for KCl crystal.

The reflection of radiation to back in MBH is may be important for MBH stabilization, MBH storage and MBH 'switch off'.

**11. Useful energy of AB- Generator.** The useful energy  $P_u$  [J] is taken from AB- Generator is

$$P_u = \xi \xi_r P. \quad (15)$$

**12. Fuel consumption is**

$$\dot{M} = P_u / c^2, \quad \text{kg}. \quad (16)$$

The fuel consumption is very small. AB-Generator is the single known method in the World now which allows full converting reasonably practical conversion of (any!) matter into energy according the Einsteinian equation  $E = mc^2$ .

**13. Specific pressure on AB-Generator cover sphere  $p$  [N/m<sup>2</sup>] and on the surface of MBH  $p_0$  is**

$$p = \frac{kP_r}{Sc} = \frac{kP_r}{4\pi r^2 c} = 2.65 \cdot 10^{-10} \frac{kP_r}{r^2}, \quad p_0 = \frac{P}{S_0 c} = \frac{\hbar c^9}{15360 \cdot 16\pi^2 G^4 M^4} \frac{1}{M^4} = 8.57 \cdot 10^{76} \frac{1}{M^4}, \quad (17)$$

where  $k = 1$  if the cover sphere absorbs the radiation and  $k \approx 2$  if the cover sphere high reflects the radiation,  $S$  is the internal area of cover sphere, m<sup>2</sup>;  $S_0$  is surface of event horizon sphere, m<sup>2</sup>;  $p_0$  is specific pressure of Hawking radiation on the event horizon surface. Note, the pressure  $p$  on cover sphere is small (see Project), but pressure  $p_0$  on event horizon surface is very high.

**14. Mass particles produced on event surface.** On event horizon surface may be also produced the mass particles with speed  $V < c$ . Let us take the best case (for leaving the BH) when their speed is radially vertical. They cannot leave the BH because their speed  $V$  is less than light speed  $c$ . The maximal radius of lifting  $r_m$  [m] is

$$dV = -gdt, \quad dV = -\frac{g}{V} dr = -\frac{GM}{V} \frac{dr}{r^2}, \quad r_m = \frac{2GM}{c^2 - V_0^2} = \frac{r_0}{1 - (V/c)^2}, \quad (18)$$

where  $g$  is gravitational acceleration of BH, m/s<sup>2</sup>;  $t$  is time, sec.;  $r_0$  is BH radius, m;  $V_0$  is particle speed on event surface, m/s<sup>2</sup>. If the  $r_m$  is less than radius of the cover sphere, the mass particles return to BH and do not influence the heat flow from BH to cover sphere. That is in the majority of cases.

**15. Explosion of MBH.** The MBH explosion produces the radiation energy

$$E_e = Mc^2. \quad (19)$$

MBH has a small mass. The explosion of MBH having  $M = 10^{-5}$  kg produces  $9 \times 10^{11}$  J. That is energy of about 10 tons of good conventional explosive ( $10^7$  J/kg). But there is a vacuum into the cover sphere and this energy is presented in radiation form. But in reality only very small part of explosion energy reaches the cover sphere, because the very strong MBH gravitation field brakes the photons and any

mass particles. Find the energy which reaches the cover sphere via:

$$dE = \xi c^2 dM, \quad \xi = \frac{r_0}{r}, \quad r_0 = \frac{2G}{c^2} M, \quad dE = \frac{2G}{r} M dM, \quad E = \frac{G}{r} M^2 = 6,674 \cdot 10^{-11} \frac{M^2}{r}. \quad (20)$$

The specific exposure radiation pressure of MBH pressure  $p_e$  [N/m<sup>2</sup>] on the cover sphere of radius  $r < r_0$  may be computed by the way:

$$p_e = \frac{E}{V} = \frac{3G}{4\pi} \frac{M^2}{r^3} = 1.6 \cdot 10^{-11} \frac{M^2}{r^3}, \quad r > r_0, \quad (21)$$

where  $V = 3/4 \pi r^3$  is volume of the cover sphere.

That way the exposure radiation pressure on sphere has very small value and presses very short time. Conventional gas balloon keeps pressure up  $10^7$  N/m<sup>2</sup> (100 atm). However, the heat impact may be high and AB- Generator design may have the reflectivity cover and automatically open windows for radiation.

Your attention is requested toward the next important result following from equations (20)-(21). Many astronomers try to find (detect) the MBH by a MBH exposure radiation. But this radiation is small, may be detected but for a short distance, does not have a specific frequency and has a variably long wavelength. This may be why during more than 30 years nobody has successfully observed MBH events in Earth environment though the theoretical estimation predicts about 100 of MBH events annually. Observers take note!

**16. Supporting the MBH in suspended (levitated) state.** The fuel injector can support the MBH in suspended state (no contact the MBH with any material surface).

The maximal suspended force equals

$$F = qV_f, \quad q = \frac{P_u}{c^2}, \quad F = \frac{P_u V_f}{c^2}, \quad (22)$$

where  $q$  is fuel consumption, kg;  $V_f$  is a fuel speed, m/s. The fuel (plasma) speed  $0.01c$  is conventionally enough for supporting the MBH in suspended state.

**17. AB-Generator as electric generator.** When the Hawking radiation reaches the cover as radio microwaves they may be straightforwardly converted to electricity because they create a different voltage between different isolated parts of the cover sphere as in an antenna. Maximal voltage which can produces the radiation wave is

$$w = \frac{\varepsilon \varepsilon_0 E^2}{2} + \frac{\mu \mu_0 H^2}{2}, \quad w = \frac{P_r}{c}, \quad (23)$$

where  $w$  is density of radiation energy, J/m<sup>3</sup>;  $E$  is electric intensity, V/m;  $H$  is magnetic intensity, T;  $\varepsilon_0 = 8.85 \times 10^{-12}$  F/m is the coefficient of the electric permeability;  $\mu_0 = 4\pi \times 10^{-7}$  N/A<sup>2</sup> is the coefficient of the magnetic permeability;  $\varepsilon = \mu = 1$  for vacuum.

Let us take moment when  $H = 0$ , then

$$E = \sqrt{\frac{2w}{\varepsilon_0}} = \sqrt{\frac{2P_r}{\varepsilon_0 c}} = 2.73 \sqrt{P_r} \quad U \approx b \pi D E, \quad b = \frac{\pi D}{0.5 \lambda} \leq 1, \quad (24)$$

$$P_e \approx b P_r, \quad \lambda = \lambda_0 \frac{r}{r_0} = 16r, \quad b = \frac{4\pi r}{16r} = \frac{\pi}{4},$$

where  $E$  is electric intensity, V/m;  $U$  is voltage of AB-generator, V;  $b$  is relative size of antenna,  $D$  is diameter of the cover sphere if the cover sphere is used as a full antenna, m;  $P_e$  is power of the electric station, W.

As you see about  $\pi/4$  of total energy produced by AB-Generator we can receive in the form of electricity and  $(1-\pi/4)$  reflects back to MBH; we may tap heat energy which convert to any form of energy by conventional (heat engine) methods. If we reflect the most part of the heat energy back into



the MBH, we can have only electricity and do not have heat flux.

If we will use the super strong and super high temperature material AB-material offered in [3] the conversion coefficient of heat machine may be very high.

**18. Critical mass of MBH located in matter environment.** Many people are afraid the MBH experiments because BH can absorb the Earth. Let us find the critical mass of MBH which can begin uncontrollably to grow into the Earth environment. That will happen when BH begins to have more mass than mass of Hawking radiation. Below is the equation for the critical mass of initial BH. The educated reader will understand the equations below without detailed explanations.

$$dV = gdt, \quad g = \frac{GM}{r^2}, \quad dt = \frac{dr}{V}, \quad VdV = gdr, \quad \int_r^c VdV = \int_r^{r_0} \frac{GM}{r^2} dr, \quad r_0 = \frac{2G}{c^2} M, \quad V^2 = c^2 \frac{r_0}{r},$$

$$V = c\sqrt{\frac{r_0}{r}}, \quad dt = \frac{\sqrt{r}dr}{c\sqrt{r_0}}, \quad \int_t^0 dt = \frac{1}{c\sqrt{r_0}} \int_r^{r_0} \sqrt{r}dr, \quad t = \frac{2}{3c\sqrt{r_0}} (r^{3/2} - r_0^{3/2}) \approx \frac{2r^{3/2}}{3cr_0^{1/2}}, \quad r = \left( \frac{3c\sqrt{r_0}}{2} t \right)^{2/3}, \quad (25)$$

$$r = 1.65G^{1/2} M^{1/3} t^{2/3}, \quad \dot{M} = \frac{P}{c^2} = \frac{\hbar c^4}{15360\pi G^2} \frac{1}{M^2} = 4 \cdot 10^{15} \frac{1}{M^2}, \quad \text{for } t = 1 \text{ s},$$

$$\dot{M}_c = \frac{4}{3} \pi r^3 \gamma = 6\pi \gamma G^{3/2} M \approx 10^{-4} \gamma M, \quad M = M_c e^{6\pi \gamma G^{3/2} t} \approx M_c e^{10^{-4} \gamma t}, \quad t = \frac{1}{6\pi \gamma G^{3/2}} \ln \frac{M}{M_c} \approx \frac{10^4}{\gamma} \ln \frac{M}{M_c},$$

where  $V$  is speed of environment matter absorbed by MBH, m/s;  $g$  is gravity acceleration of MBH, m/s;  $r$  is distance environment matter to MBH center, m;  $t$  is time, sec;  $\dot{M}$  is mass loss by MBH, kg;  $\dot{M}_c$  is mass taken from Earth environment by MBH, kg;  $\gamma$  is density of Earth environment, kg/m<sup>3</sup>;  $M_c$  is critical mass of MBH when one begin uncontrollable grows, kg;  $t$  is time, sec.

Let us to equate the mass  $\dot{M}$  radiated by MBH to mass  $\dot{M}_c$  absorbed by MBH from Earth environment, we obtain the critical mass  $M_c$  of MBH for any environment:

$$M_c^3 = \frac{\hbar c^4}{92160\pi^2 G^3} \frac{1}{\gamma} = 3.17 \cdot 10^{24} \frac{1}{\gamma}, \quad \text{or } \gamma = 3.17 \cdot 10^{24} \frac{1}{M_c^3}, \quad (26)$$

If MBH having mass  $M = 10^7$  kg (10 thousands tons) is put in water ( $\gamma = 1000$  kg/m<sup>3</sup>), this MBH can begin uncontrollable runaway growth and in short time ( $\sim 74$  sec) can consume the Earth into a black hole having diameter  $\sim 9$  mm. If this MBH is located in the sea level atmosphere ( $\gamma = 1.29$  kg/m<sup>3</sup>), the initial MBH must has critical mass  $M = 10^8$  kg (100 thousand tons). The critical radius of MBH is very small. In the first case ( $M = 10^7$  kg)  $r_0 = 1.48 \times 10^{-20}$  m, in the second case ( $M = 10^8$  kg)  $r_0 = 1.48 \times 10^{-19}$  m. Our MBH into AB-Generator is not dangerous for Earth because it is located in vacuum and has mass thousands to millions times less than the critical mass.

However, in a moment of extreme speculation, if far future artificial intelligence (or super-small reasoning) beings will be created from nuclear matter [3] they can convert the Earth into a black hole to attempt to access quick travel to other stars (Solar systems), past and future Universes and even possibly past and future times.

**19. General note.** We got our equations in assumption  $\lambda/\lambda_0 = r/r_0$ . If  $\lambda/\lambda_0 = (r/r_0)^{0.5}$  or other relation, the all above equations may be easy modified.

## AB-Generator as Photon Rocket

The offered AB- Generator may be used as the most efficient photon propulsion system (photon rocket). The photon rocket is the dream of all astronauts and space engineers, a unique vehicle) which would make practical interstellar travel. But a functioning photon rocket would require gigantic

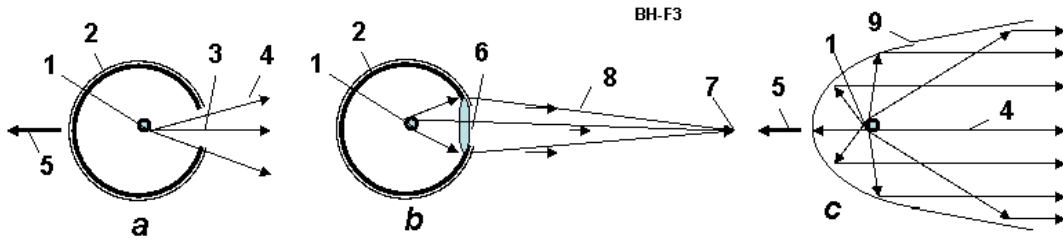
energy. The AB- Generator can convert any matter in energy (radiation) and gives the maximum theoretical efficiency.

The some possible photon propulsion system used the AB –Generator is shown in Fig.7. In simplest version (a) the cover of AB generator has window 3, the radiation goes out through window and produces the thrust. More complex version (c) has the parabolic reflector, which sends all radiation in one direction and increases the efficiency. If an insert in the AB- Generator covers the lens 6 which will focuses the radiation in a given direction, at the given point the temperature will be a billions degree (see Equation (2)) and AB- Generator may be used as a photon weapon.

The maximal thrust  $T$  of the photon engine having AB- Generator may be computed (estimated) by equation:

$$T = \dot{M}c, \quad N, \quad (26)$$

For example, the AB-generator, which spends only 1 gram of matter per second, will produce a thrust  $3 \times 10^5$  N or 30 tons.



**Fig.7.** AB- Generator as Photon Rocket and Radiation (Photon) Weapon. (a) AB- Generator as a Simplest Photon Rocket; (b) AB- Generator as focused Radiation (photon, light or laser) weapon; (c) Photon Rocket with Micro-Black Hole of AB-Generator. *Notations:* 1 – control MBH; 2 – spherical cover of AB-Generator; 3 – window in spherical cover; 4 – radiation of BH; 5 – thrust; 6 – lens in window of cover; 7 – aim; 8 – focused radiation; 9 – parabolic reflector.

## Project of AB-Generator

Let us to estimate the possible energy production of an AB-Generator. That is not optimal, that is example of computation and possible parameters. Let us take the MBH mass  $M = 10^{-5}$  kg and radius of the cover sphere  $r = 5$  m. No reflection. Using the equations (1)-(24) we receive:

$$\begin{aligned} P &= 3.56 \cdot 10^{32} / M^2 = 3,56 \cdot 10^{42} \quad \text{W}, \\ r_0 &= 1.48 \cdot 10^{-27} M = 1.48 \cdot 10^{-32} \quad \text{m}, \\ \xi &= r_0 / r = 2.96 \cdot 10^{-33}, \\ P_r &= \xi P = 1.05 \cdot 10^{10}, \quad P_u = \xi \xi_r P = P_r, \quad \text{W}, \quad \xi_r = 1. \\ \lambda_0 &= 3,73 \cdot 10^{-26} M = 3.73 \cdot 10^{-31} \quad \text{m}. \\ \lambda &= 16 \cdot r = 80 \quad \text{m}. \\ p &= \frac{P_r}{4\pi c r^2} = 0.111 \frac{N}{m^2}, \quad c = 3 \cdot 10^8 \quad \text{m/s}, \\ \dot{M} &= P_u / c^2 = 1.17 \cdot 10^{-7} \quad \text{kg/s}, \\ p_e &= 1.6 \cdot 10^{-11} \frac{M^2}{r^3} = 1.28 \cdot 10^{-23} \quad \text{N/m}^2 \end{aligned} \quad (27)$$

Remain the main notations in equations (27):  $P_r = P_u = 1.05 \times 10^{10}$  W is the useful energy ( $\pi/4$  of this energy may be taken as electric energy by cover antenna, the rest is taken as heat);  $\lambda = 80$  m is

wavelength of radiation at cover sphere (that is not dangerous for people);  $\dot{M} = 1.17 \times 10^{-7}$  kg/s is fuel consumption;  $r_o = 1.48 \times 10^{-32}$  m is radius of MBH;  $p_e = 1.28 \times 10^{-23}$  N/m<sup>2</sup> is explosion pressure of MBH.

Look your attention - the explode pressure is very small. That is less in billions of time then radiation pressure on the cover surface  $p = 0.111$  N/m<sup>2</sup>. That is no wonder because BH takes back the energy with that spent for acceleration the matter in eating the matter. No dangerous from explosion of MBH.

Heat transfer and internal electric power are

$$q = \frac{P_u}{S} = \frac{P_u}{4\pi r^2} = 3.34 \cdot 10^7 \frac{\text{W}}{\text{m}^2},$$

$$\text{For } \delta = 2 \cdot 10^{-3} \text{ m, } \lambda_h = 100, \Delta T \approx q\delta / \lambda_h = 668^\circ \text{ K,} \quad (28)$$

$$E = 2.73\sqrt{P_r} = 2.8 \cdot 10^5 \text{ V/m, } U = E \cdot 2r = 2.8 \cdot 10^6 \text{ V, } P_e = P_r / 8 = 1.31 \cdot 10^9 \text{ W,}$$

where  $q$  is specific heat transfer through the cover sphere,  $S$  is internal surface of the cover sphere, m<sup>2</sup>;  $\delta$  is thickness of the cover sphere wall, m;  $\lambda_h$  is heat transfer coefficient for steel;  $\Delta T$  is difference temperature between internal and external walls of the cover sphere;  $E$  is electric intensity from radiation on cover sphere surface, V/m;  $U$  is maximal electric voltage, V;  $P_e$  is electric power, W.

We get the power heat and electric output of a AB-Generator as similar to a very large complex of present day Earth's electric power stations ( $P_r = 10^{10}$  W, ten billion of watts). The AB-Generator is cheaper by a hundred times than a conventional electric station, especially since, we may reflect a heat energy back to the MBH and not built a heat engine with all the problems of conventional power conversion equipment (using only electricity from spherical cover as antenna).

We hope the Large Hadron Collider at CERN can get the initial MBH needed for AB-Generator. The other way to obtain one is to find the Planck MBH (remaining from the time of the Big Bang and former MBH) and grow them to target MBH size.

## Results

1. Author has offered the method and installation for converting any conventional matter to energy according the Einstein's equation  $E = mc^2$ , where  $m$  is mass of matter, kg;  $c = 3 \cdot 10^8$  is light speed, m/s.
2. The Micro Black Hole (MBH) is offered for this conversion.
3. Also is offered the control fuel guns and radiation reflector for explosion prevention of MBH.
4. Also is offered the control fuel guns and radiation reflector for the MBH control.
5. Also is offered the control fuel guns and radiation reflector for non-contact suspension (levitation) of the MBH.
6. For non contact levitation of MBH the author also offers:
  - a) Controlled charging of MBH and of ends of the fuel guns.
  - b) Control charging of rotating MBH and control of electric magnets located on the ends of the fuel guns or out of the reflector-heater sphere.
7. The author researches show the very important fact: A strong gamma radiation produced by Hawking radiation loses energy after passing through the very strong gravitational MBH field. The MBH radiation can reach the reflector-heater as the light or short-wave radio radiation. That is very important for safety of the operating crew of the AB- Generator.
8. The author researches show: The matter particles produced by the MBH cannot escape from MBH and can not influence the Hawking radiation.
9. The author researches show another very important fact: The MBH explosion (hundreds and thousands of TNT tons) in radiation form produces a small pressure on the reflector-heater (cover

sphere) and does not destroys the AB-generator (in a correct design of AB-generator!). That is very important for safety of the operating crew of the AB-generator.

10. The author researches show another very important fact: the MBH cannot capture by oneself the surrounding matter and cannot automatically grow to consume the planet.
11. As the initial MBH can be used the Planck's (quantum) MBH which *may* be everywhere. The offered fuel gun may to grow them (or decrease them) to needed size or the initial MBH may be used the MBH produce Large Hadron Collider (LHC) at CERN. Some scientists assume LHC will produce one MBH every second (86,400 MBH in day). The cosmic radiation also produces about 100 MBH every year.
12. The spherical dome of MBH may convert part of the radiation energy to electricity.
13. A correct design of MBH generator does not produce the radioactive waste of environment.
14. The attempts of many astronomers find (detect) the MBH by a MBH exposure radiation will not be successful without knowing the following: The MBH radiation is small, may be detected only over a short distance, does not have specific frequency and has a variable long wavelength.

## Discussing

We got our equations in assumption  $\lambda/\lambda_o = r/r_o$ . If  $\lambda/\lambda_o = (r/r_o)^{0.5}$  or other relation, the all above equations may be easy modified.

The Hawking article was published 34 years ago (1974)[1]. After this time the hundreds of scientific works based in Hawking work appears. No facts are known which creates doubts in the possibility of Hawking radiation but it is not proven either. The Hawking radiation may not exist. The Large Hadron Collider has the main purpose to create the MBHs and detect the Hawking radiation.

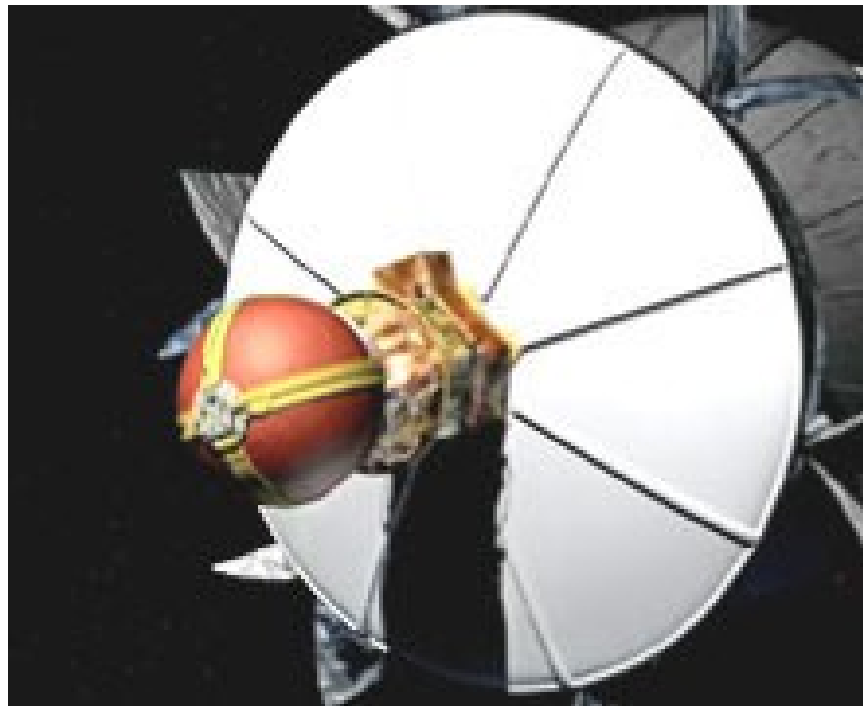
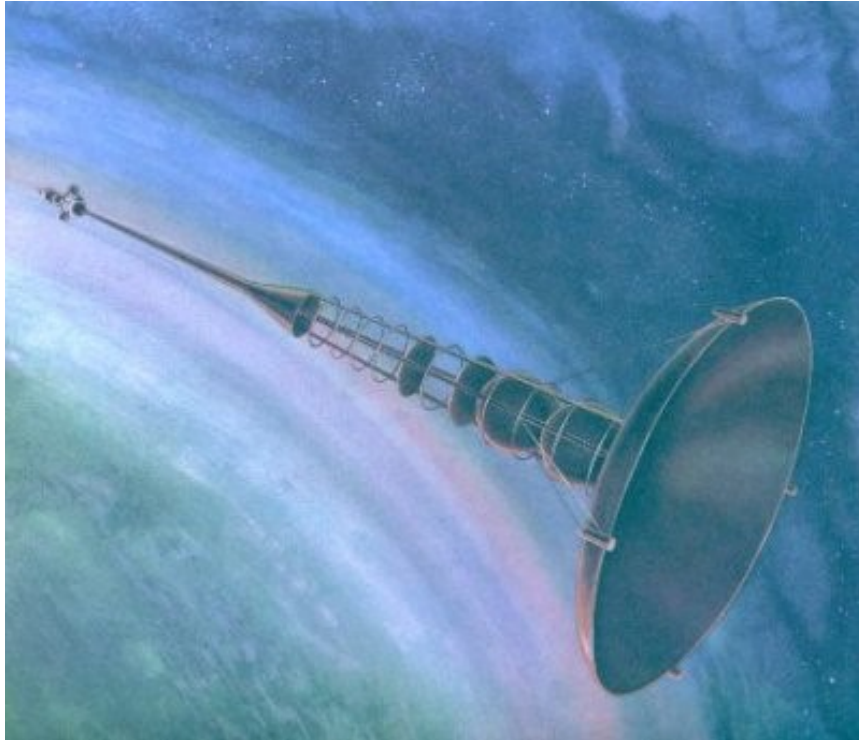
## Conclusion

The AB-Generator could create a revolution in many industries (electricity, car, ship, transportation, etc.). That allows designing photon rockets and flight to other star systems. The maximum possible efficiency is obtained and a full solution possible for the energy problem of humanity. These overwhelming prospects urge us to research and develop this achievement of science [1]-[5].

## References:

- (The reader may find some of related articles at the author's web page <http://Bolonkin.narod.ru/p65.htm>; <http://arxiv.org> , <http://www.scribd.com> search "Bolonkin"; <http://aiaa.org> search "Bolonkin"; and in the author's books: "Non-Rocket Space Launch and Flight", Elsevier, London, 2006, 488 pages; "New Concepts, Ideas, Innovations in Aerospace, Technology and Human Science", NOVA, 2008, 502 pages and "Macro-Projects: Environment and Technology", NOVA 2009, 536 pages).
1. Hawking, S.W. (1974), "[Black hole explosions?](#)", *Nature* **248**: 30–31, [doi:10.1038/248030a0](#), <http://www.nature.com/nature/journal/v248/n5443/abs/248030a0.html>.
  2. Bolonkin A.A., *Non-Rocket Space Launch and Flight*, Elsevier, 2006, 488 pgs. <http://Bolonkin.narod.ru/p65.htm> , <http://www.scribd.com/doc/24056182> .
  3. Bolonkin A.A., Converting of Matter to Nuclear Energy by AB-Generator. *American Journal of Engineering and Applied Sciences*. 2 (2), 2009, p.683-693. [on line] <http://www.scipub.org/fulltext/ajeas/ajeas24683-693.pdf> , <http://www.scribd.com/doc/24048466> .
  4. Bolonkin A.A., Femtotechnology. Nuclear AB-Matter with Fantastic Properties, *American Journal of Engineering and Applied Sciences*. 2 (2), 2009, p.501-514. [On line]: <http://www.scipub.org/fulltext/ajeas/ajeas22501-514.pdf>, or <http://www.scribd.com/doc/24046679> .
  5. *Wikipedia*. Some background material in this article is gathered from Wikipedia under the Creative Commons license. <http://wikipedia.org> .

## Possible form of photon rocket



## Chapter 2

# Femtotechnology: the Strongest AB-Matter with Fantastic Properties and their Applications in Aerospace

## Abstract

At present the term ‘nanotechnology’ is well known – in its’ ideal form, the flawless and completely controlled design of conventional molecular matter from molecules or atoms. Such a power over nature would offer routine achievement of remarkable properties in conventional matter, and creation of metamaterials where the structure not the composition brings forth new powers of matter.

But even this yet unachieved goal is not the end of material science possibilities. The author herein offers the idea of design of new forms of nuclear matter from nucleons (neutrons, protons), electrons, and other nuclear particles. He shows this new ‘AB-Matter’ has extraordinary properties (for example, tensile strength, stiffness, hardness, critical temperature, superconductivity, supertransparency, zero friction, etc.), which are up to millions of times better than corresponding properties of conventional molecular matter. He shows concepts of design for aircraft, ships, transportation, thermonuclear reactors, constructions, and so on from nuclear matter. These vehicles will have unbelievable possibilities (e.g., invisibility, ghost-like penetration through any walls and armour, protection from nuclear bomb explosions and any radiation flux, etc.)

People may think this fantasy. But fifteen years ago most people and many scientists thought – nanotechnology is fantasy. Now many groups and industrial labs, even startups, spend hundreds of millions of dollars for development of nanotechnological-range products (precise chemistry, patterned atoms, catalysts, metamaterials, etc) and we have nanotubes (a new material which does not exist in Nature!) and other achievements beginning to come out of the pipeline in prospect. Nanotubes are stronger than steel by a hundred times—surely an amazement to a 19<sup>th</sup> Century observer if he could behold them.

Nanotechnology, in near term prospect, operates with objects (molecules and atoms) having the size in nanometer ( $10^{-9}$  m). The author here outlines perhaps more distant operations with objects (nuclei) having size in the femtometer range, ( $10^{-15}$  m, millions of times less smaller than the nanometer scale). The name of this new technology is femtotechnology.

**Key words:** femtotechnology, nuclear matter, artificial AB-Matter, superstrength matter, superthermal resistance, invisible matter, super-protection from nuclear explosion and radiation.

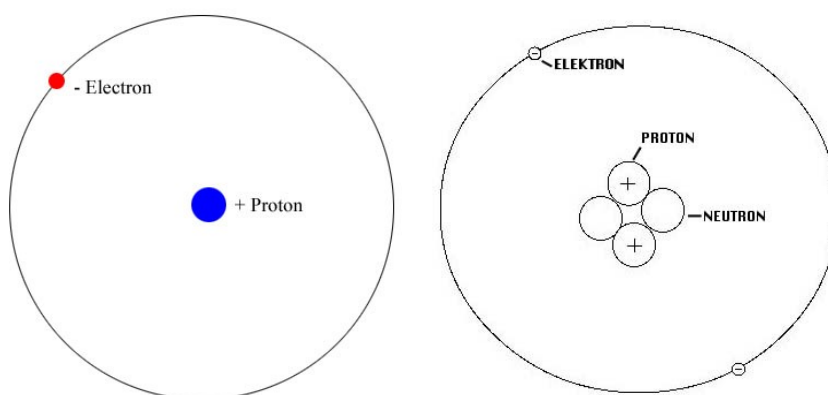
## Introduction

### Brief information concerning the atomic nucleus.

Atoms are the smallest (size is about some  $10^{-8}$  m) neutral particles into which matter can be divided by chemical reactions. An atom consists of a small, heavy nucleus surrounded by a relatively large, light cloud of electrons. Each type of atom corresponds to a specific chemical element. To date, 117 elements have been discovered (atomic numbers 1-116 and 118), and the first 111 have received official names. The well-known periodic table provides an overview. Atoms consist of protons and neutrons within the nucleus. Within these particles, there are smaller particles still which are then made up of even smaller particles still.

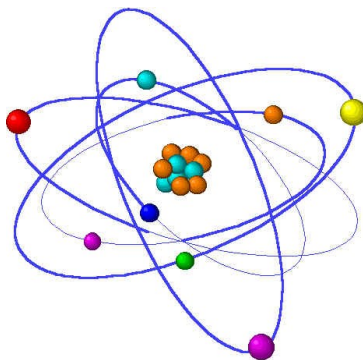
Molecules are the smallest particles into which a non-elemental substance can be divided while

maintaining the physical properties of the substance. Each type of molecule corresponds to a specific chemical compound. Molecules are a composite of two or more atoms.



**Fig.1.** (Left) Hydrogen atom contains one proton and one electron.  
(Right) Helium atom contains two protons, two neutrons and two electron.

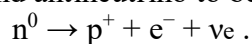
Atoms contain small (size is about some  $10^{-15}$  m) nuclei and electrons orbit around these nuclei. The nuclei of most atoms consist of protons and neutrons, which are therefore collectively referred to as nucleons. The number of protons in a nucleus is the atomic number and defines the type of element the atom forms. The number of neutrons determines the isotope of an element. For example, the carbon-12 isotope has 6 protons and 6 neutrons, while the carbon-14 isotope has 6 protons and 8 neutrons.



**Fig.2.** More complex atom which contains many protons, neutrons and electrons.

While bound neutrons in stable nuclei are stable, free neutrons are unstable; they undergo beta decay with a lifetime of just under 15 minutes. Free neutrons are produced in nuclear fission and fusion. Dedicated neutron sources like research reactors and spallation sources produce free neutrons for the use in irradiation and in neutron scattering experiments.

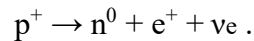
Outside the nucleus, free neutrons are unstable and have a mean lifetime of  $885.7 \pm 0.8$  s, decaying by emission of a negative electron and antineutrino to become a proton:



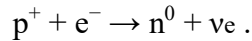
This decay mode, known as beta decay, can also transform the character of neutrons within unstable nuclei.

Bound inside a nucleus, protons can also transform via inverse beta decay into neutrons. In this case, the transformation occurs by emission of a positron (antielectron) and a neutrino (instead of an antineutrino):

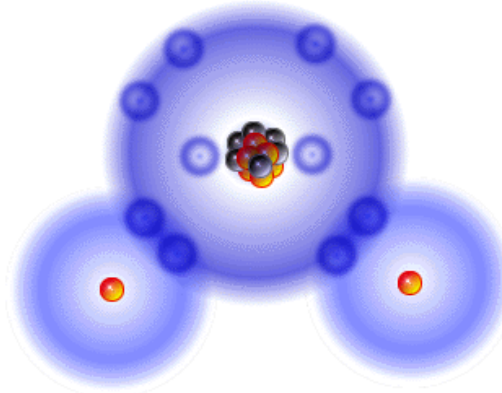




The transformation of a proton to a neutron inside of a nucleus is also possible through electron capture:



### Water Molecule



**Fig.3.** Molecule contains some atoms connected by its electrons.

Positron capture by neutrons in nuclei that contain an excess of neutrons is also possible, but is hindered because positrons are repelled by the nucleus, and quickly annihilate when they encounter negative electrons.

When bound inside of a nucleus, the instability of a single neutron to beta decay is balanced against the instability that would be acquired by the nucleus as a whole if an additional proton were to participate in repulsive interactions with the other protons that are already present in the nucleus. As such, although free neutrons are unstable, bound neutrons are not necessarily so. The same reasoning explains why protons, which are stable in empty space, may transform into neutrons when bound inside of a nucleus.

A thermal neutron is a free neutron that is Boltzmann distributed with  $kT = 0.024 \text{ eV}$  ( $4.0 \times 10^{-21} \text{ J}$ ) at room temperature. This gives characteristic (not average, or median) speed of 2.2 km/s.

Four forces active between particles: strong interaction, weak interacting, charge force (Coulomb force) and gravitation force. The strong interaction is the most strong force in short nuclei distance, the gravitation is very small into atom.

Beta decay and electron capture are types of radioactive decay and are both governed by the weak interaction.

#### ***Basic properties of the nuclear force.***

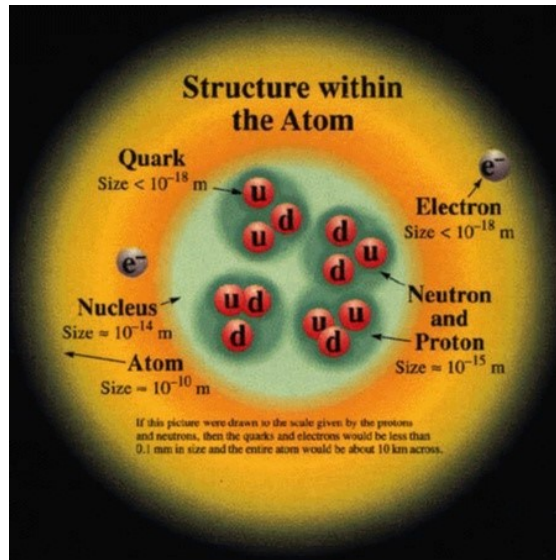
The nuclear force is only felt among hadrons. In particle physics, a hadron is a bound state of quarks (particles into nucleus). Hadrons are held together by the strong force, similarly to how atoms are held together by the electromagnetic force. There are two subsets of hadrons: baryons and mesons; the most well known baryons are protons and neutrons.

At much smaller separations between nucleons the force is very powerfully repulsive, which keeps the nucleons at a certain average separation. Beyond about 1.7 femtometer (fm) separation, the force drops to negligibly small values.

At short distances, the nuclear force is stronger than the Coulomb force; it can overcome the Coulomb repulsion of protons inside the nucleus. However, the Coulomb force between protons has a much larger range and becomes the only significant force between protons when their separation exceeds about 2.5 fm.

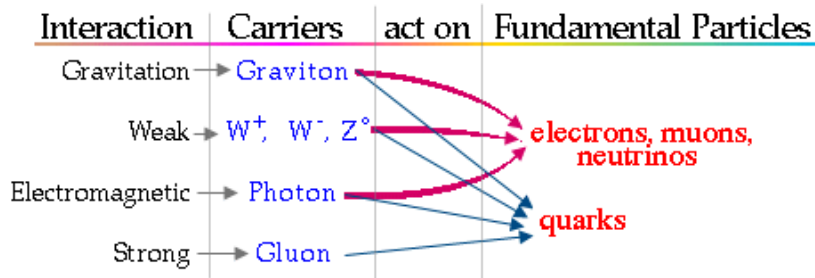
The nuclear force is nearly independent of whether the nucleons are neutrons or protons. This

property is called *charge independence*. It depends on whether the spins of the nucleons are parallel or antiparallel, and has a noncentral or *tensor* component. This part of the force does not conserve orbital angular momentum, which is a constant of motion under central forces.



**Fig.4.** Atom and nucleus structure. Proton and neutron contain quarks.

The **nuclear force** (or **nucleon-nucleon interaction** or **residual strong force**) is the force between two or more nucleons. It is responsible for binding of protons and neutrons into atomic nuclei. To a large extent, this force can be understood in terms of the exchange of virtual light mesons, such as the pions. Sometimes the nuclear force is called the residual strong force, in contrast to the strong interactions which are now understood to arise from quantum chromodynamics (QCD). This phrasing arose during the 1970s when QCD was being established. Before that time, the *strong nuclear force* referred to the inter-nucleon potential. After the verification of the quark model, *strong interaction* has come to mean QCD.



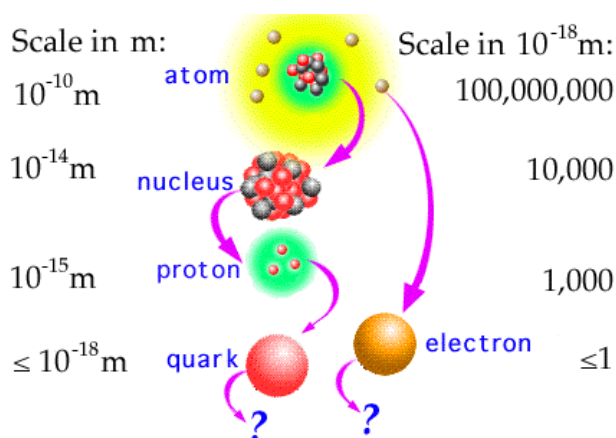
**Fig.5.** Interaction between fundamental particles.

A **subatomic particle** is an elementary or composite particle smaller than an atom. Particle physics and nuclear physics are concerned with the study of these particles, their interactions, and non-atomic matter.

Elementary particles are particles with no measurable internal structure; that is, they are not composed of other particles. They are the fundamental objects of quantum field theory. Many families and sub-families of elementary particles exist. Elementary particles are classified according to their

spin. Fermions have half-integer spin while bosons have integer spin. All the particles of the Standard Model have been observed, with the exception of the Higgs boson.

Subatomic particles include the atomic constituents electrons, protons, and neutrons. Protons and neutrons are composite particles, consisting of quarks. A proton contains two up quarks and one down quark, while a neutron consists of one up quark and two down quarks; the quarks are held together in the nucleus by gluons. There are six different types of quark in all ('up', 'down', 'bottom', 'top', 'strange', and 'charm'), as well as other particles including photons and neutrinos which are produced copiously in the sun. Most of the particles that have been discovered are encountered in cosmic rays interacting with matter and are produced by scattering processes in particle accelerators. There are dozens of known subatomic particles.



**Fig.6.** Size and scale of nucleus particles.

### Degenerate matter.

Degenerate matter is matter which has such very high density that the dominant contribution to its pressure rises from the Pauli exclusion principle. The pressure maintained by a body of degenerate matter is called the degeneracy pressure, and arises because the Pauli principle forbids the constituent particles to occupy identical quantum states. Any attempt to force them close enough together that they are not clearly separated by position must place them in different energy levels. Therefore, reducing the volume requires forcing many of the particles into higher-energy quantum states. This requires additional compression force, and is manifest as a resisting pressure.

Imagine that there is a plasma, and it is cooled and compressed repeatedly. Eventually, we will not be able to compress the plasma any further, because the Exclusion Principle states that two particles cannot be in the exact same place at the exact same time. When in this state, since there is no extra space for any particles, we can also say that a particle's location is extremely defined. Therefore, since (according to the Heisenberg Uncertainty Principle)  $\Delta p \Delta x = \hbar / 2$  where  $\Delta p$  is the uncertainty in the particle's momentum and  $\Delta x$  is the uncertainty in position, then we must say that their momentum is extremely uncertain since the molecules are located in a very confined space. Therefore, even though the plasma is cold, the molecules must be moving very fast on average. This leads to the conclusion that if you want to compress an object into a very small space, you must use tremendous force to control its particles' momentum.

Unlike a classical ideal gas, whose pressure is proportional to its temperature ( $PV = NkT$ , where  $P$  is pressure,  $V$  is the volume,  $N$  is the number of particles (typically atoms or molecules),  $k$  is Boltzmann's constant, and  $T$  is temperature), the pressure exerted by degenerate matter depends only weakly on its temperature. In particular, the pressure remains nonzero even at absolute zero temperature. At

relatively low densities, the pressure of a fully degenerate gas is given by  $P = Kn^{5/3}$ , where  $K$  depends on the properties of the particles making up the gas. At very high densities, where most of the particles are forced into quantum states with relativistic energies, the pressure is given by  $P = Kn^{4/3}$ , where  $K$  again depends on the properties of the particles making up the gas.

Degenerate matter still has normal thermal pressure, but at high densities the degeneracy pressure dominates. Thus, increasing the temperature of degenerate matter has a minor effect on total pressure until the temperature rises so high that thermal pressure again dominates total pressure.

Exotic examples of degenerate matter include neutronium, strange matter, metallic hydrogen and white dwarf matter. Degeneracy pressure contributes to the pressure of conventional solids, but these are not usually considered to be degenerate matter as a significant contribution to their pressure is provided by the interplay between the electrical repulsion of atomic nuclei and the screening of nuclei from each other by electrons allocated among the quantum states determined by the nuclear electrical potentials. In metals it is useful to treat the conduction electrons alone as a degenerate, free electron gas while the majority of the electrons are regarded as occupying bound quantum states. This contrasts with the case of the degenerate matter that forms the body of a white dwarf where all the electrons would be treated as occupying free particle momentum states.

## Pauli principle

The **Pauli exclusion principle** is a quantum mechanical principle formulated by Wolfgang Pauli in 1925. It states that no two identical fermions may occupy the same quantum state *simultaneously*. A more rigorous statement of this principle is that, for two identical fermions, the total wave function is anti-symmetric. For electrons in a single atom, it states that no two electrons can have the same four quantum numbers, that is, if  $n$ ,  $l$ , and  $m_l$  are the same,  $m_s$  must be different such that the electrons have opposite spins.

In relativistic quantum field theory, the Pauli principle follows from applying a rotation operator in imaginary time to particles of half-integer spin. It does not follow from any spin relation in nonrelativistic quantum mechanics.

The Pauli exclusion principle is one of the most important principles in physics, mainly because the three types of particles from which ordinary matter is made—electrons, protons, and neutrons—are all subject to it; consequently, all material particles exhibit space-occupying behavior. The Pauli exclusion principle underpins many of the characteristic properties of matter from the large-scale stability of matter to the existence of the periodic table of the elements. Particles with antisymmetric wave functions are called fermions—and obey the Pauli exclusion principle. Apart from the familiar electron, proton and neutron, these include [neutrinos](#) and quarks (from which protons and neutrons are made), as well as some atoms like helium-3. All fermions possess "half-integer spin", meaning that they possess an intrinsic angular momentum whose value is  $\hbar = h / 2\pi$  (Planck's constant divided by  $2\pi$ ) times a half-integer ( $1/2$ ,  $3/2$ ,  $5/2$ , etc.). In the theory of quantum mechanics, fermions are described by "antisymmetric states", which are explained in greater detail in the theory on identical particles. Particles with integer spin have a symmetric wave function and are called bosons; in contrast to fermions, they may share the same quantum states. Examples of bosons include the photon, the Cooper pairs responsible for superconductivity, and the W and Z bosons.

A more rigorous proof was provided by Freeman Dyson and Andrew Lenard in 1967, who considered the balance of attractive (electron-nuclear) and repulsive (electron-electron and nuclear-nuclear) forces and showed that ordinary matter would collapse and occupy a much smaller volume without the Pauli principle.

Neutrons are the most "rigid" objects known - their Young modulus (or more accurately, bulk modulus) is 20 orders of magnitude larger than that of diamond.

For white dwarfs the degenerate particles are the electrons while for neutron stars the degenerate particles are neutrons. In degenerate gas, when the mass is increased, the pressure is increased, and the particles become spaced closer together, so the object becomes smaller. Degenerate gas can be compressed to very high densities, typical values being in the range of  $10^7$  grams per cubic centimeter.

Preons are subatomic particles proposed to be the constituents of quarks, which become composite particles in preon-based models.

## Neutron stars

A neutron star is a large gravitationally-bound lump of electrically neutral nuclear matter, whose pressure rises from zero (at the surface) to an unknown value in the center.

A **neutron star** is a type of remnant that can result from the gravitational collapse of a massive star during a Type II, Type Ib or Type Ic supernova event. Such stars are composed almost entirely of neutrons, which are subatomic particles with zero electrical charge and roughly the same mass as protons.

A typical neutron star has a mass between 1.35 and about 2.1 solar masses, with a corresponding radius of about 12 km if the Akmal-Pandharipande-Ravenhall (APR) Equation of state (EOS) is used. In contrast, the Sun's radius is about 60,000 times that. Neutron stars have overall densities predicted by the APR EOS of  $3.7 \times 10^{17}$  ( $2.6 \times 10^{14}$  times Solar density) to  $5.9 \times 10^{17}$  kg/m<sup>3</sup> ( $4.1 \times 10^{14}$  times Solar density). which compares with the approximate density of an atomic nucleus of  $3 \times 10^{17}$  kg/m<sup>3</sup>. The neutron star's density varies from below  $1 \times 10^9$  kg/m<sup>3</sup> in the crust increasing with depth to above  $6$  or  $8 \times 10^{17}$  kg/m<sup>3</sup> deeper inside.

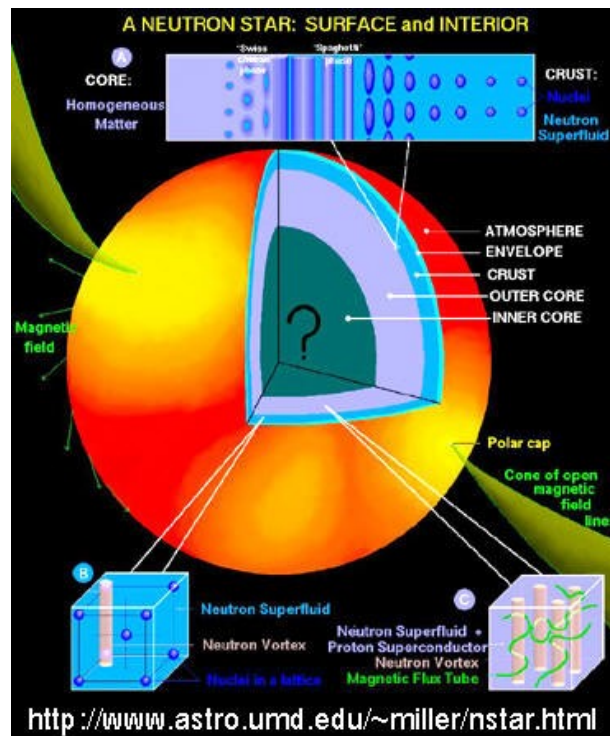


Fig.7. Probability structure of neutron star.

In general, compact stars of less than 1.44 solar masses, the Chandrasekhar limit, are white dwarfs; above 2 to 3 solar masses (the Tolman-Oppenheimer-Volkoff limit), a quark star might be created, however this is uncertain. Gravitational collapse will always occur on any star over 5 solar masses, inevitably producing a black hole.

The gravitational field at the star's surface is about  $2 \times 10^{11}$  times stronger than on Earth. The escape velocity is about 100,000 km/s, which is about one third the speed of light. Such a strong gravitational field acts as a gravitational lens and bends the radiation emitted by the star such that parts of the normally invisible spectrum near the surface become visible.

The gravitational binding energy of a two solar mass neutron star is equivalent to the total conversion of one solar mass to energy (From the law of mass-energy equivalence,  $E=mc^2$ ). That energy was released during the supernova explosion.

A neutron star is so dense that one teaspoon (5 millilitre) of its material would have a mass over  $5 \times 10^{12}$  kg. The resulting force of gravity is so strong that if an object were to fall from just one meter high it would hit the surface of the neutron star at 2 thousand kilometers per second, or 4.3 million miles per hour.

The Equation of state (EOS) for a Neutron star is still not known as of 2008.

On the basis of current models, the matter at the surface of a neutron star is composed of ordinary atomic nuclei as well as electrons.

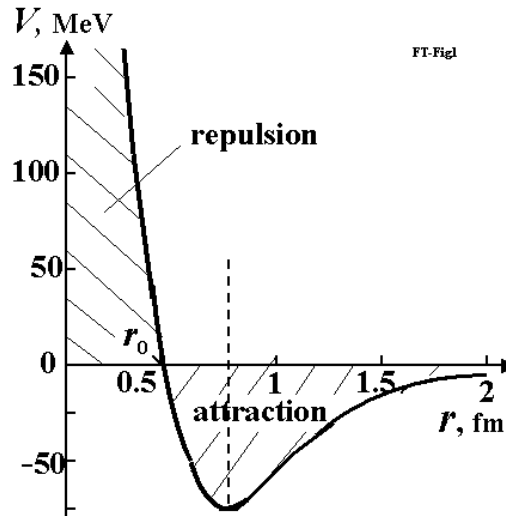
## Innovations and computations

**Short information about atom and nuclei.** Conventional matter consists of atoms and molecules. Molecules are collection of atoms. The atom contains a nucleus with proton(s) and usually neutrons (Except for Hydrogen-1) and electrons revolve around this nucleus. Every particle may be characterized by parameters as mass, charge, spin, electric dipole, magnetic moment, etc. There are four forces active between particles: strong interaction, weak interaction, electromagnetic charge (Coulomb) force and gravitational force. The nuclear force dominates at distances up to 2 fm (femto,  $1 \text{ fm} = 10^{-15} \text{ m}$ ). They are hundreds of times more powerful than the charge (Coulomb force and million-millions of times more than gravitational force. Charge (Coulomb) force is effective at distances over 2 fm. Gravitational force is significant near and into big masses (astronomical objects such as planets, stars, white dwarfs, neutron stars and black holes). Strong force is so overwhelmingly powerful that it forces together the positively charged protons, which would repel one from the other and fly apart without it. The strong force is key to the relationship between protons, neutrons and electrons. They can keep electrons into or near nuclei. Scientists conventionally take into attention only of the strong force when they consider the nuclear and near nuclear size range, for the other forces on that scale are negligible by comparison for most purposes.

Strong nuclear forces are anisotropic (non spherical, force distribution not the same in all directions equally), which means that they depend on the relative orientation of the nucleus.

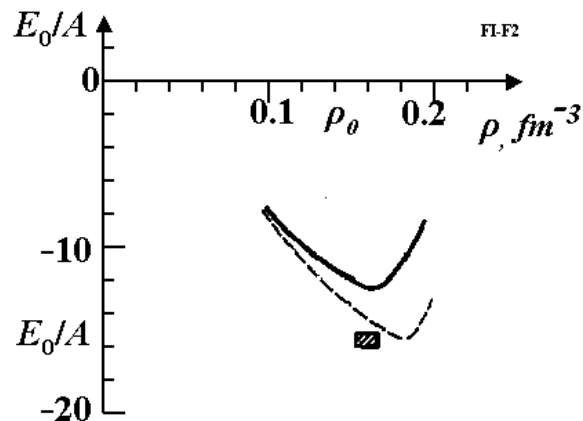
Typical nuclear energy (force) is presented in fig.8. When it is positive the nuclear force repels the other atomic particles (protons, neutrons, electrons). When nuclear energy is negative, it attracts them up to a distance of about 2 fm. The value  $r_0$  usually is taken as radius of nucleus. The computation of strong nuclear force - interaction energy of one nucleus via specific density of one nucleus in given point – is present in Fig.9. The solid line is as computed by Berkner's method [7] with 2 correlations, dotted line is computer generated with 3 correlations, square is experimental. Average interaction energy between to nucleus is about 8 MeV, distance where the attractive strong nuclear force activates is at about 1 – 1.2 fm.





**Fig.8.** Typical nuclear force of nucleus. When nucleon is at distance of less than 1.8 fm, it is attracted to nucleus. When nucleon is very close, it is repulsed from nucleus.

(Reference from <http://www.physicum.narod.ru> , Vol. 5 p. 670).



**Fig.9.** Connection (interaction) energy of one nucleon via specific density of one nucleon in given point. Firm line is computed by Berkner's method with 2 correlations, dotted line is computer with 3 correlations, square is experiment. (Reference from <http://www.physicum.narod.ru> , Vol. 5 p. 655).

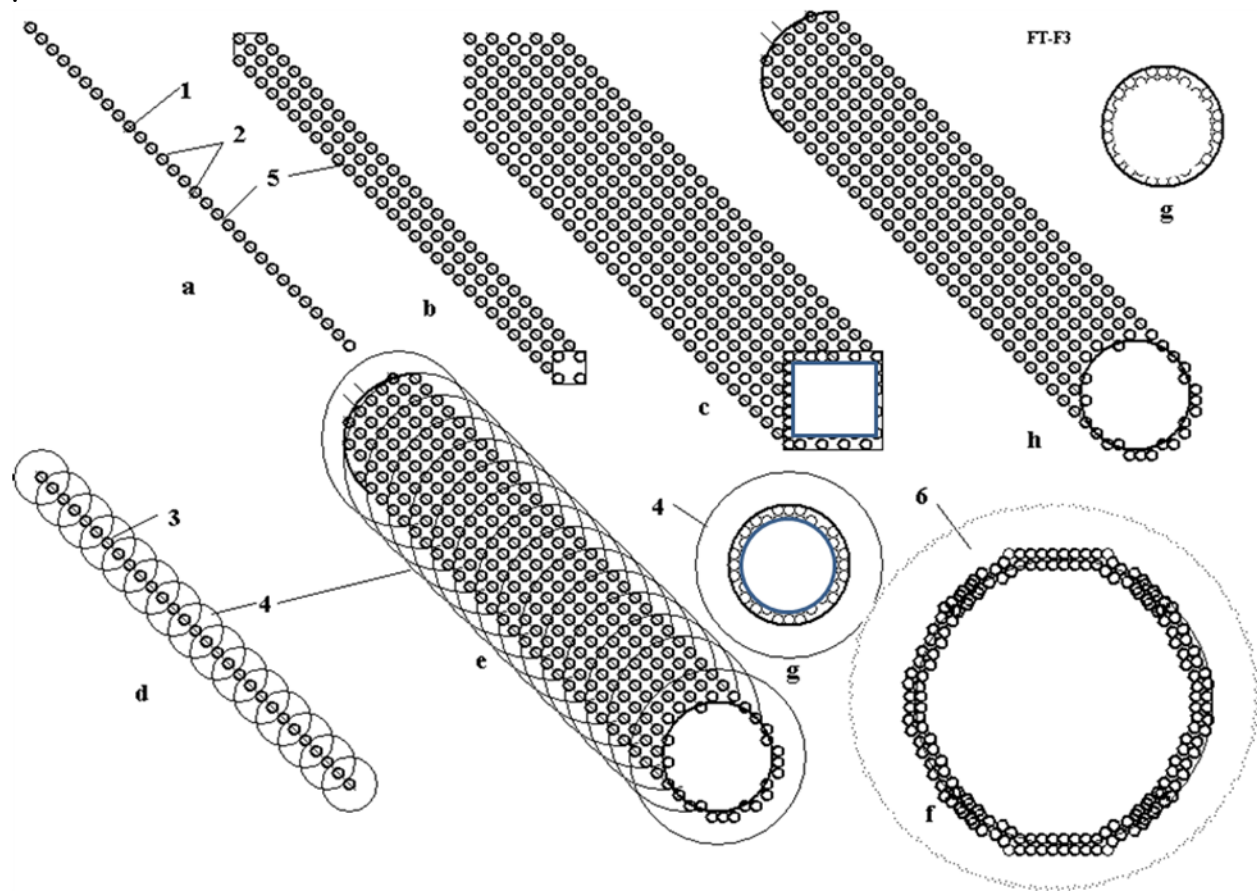
**2. AB-Matter.** In conventional matter made of atoms and molecules the nucleons (protons, neutrons) are located in the nucleus, but the electrons rotate in orbits around nucleus in distance in millions times more than diameter of nucleus. Therefore, in essence, what we think of as solid matter contains a --relatively! --'gigantic' vacuum (free space) where the matter (nuclei) occupies but a very small part of the available space. Despite this unearthly emptiness, when you compress this (normal, non-degenerate) matter the electrons located in their orbits repel atom from atom and resist any great increase of the matter's density. Thus it feels solid to the touch.

The form of matter containing and subsuming all the atom's particles into the nucleus is named *degenerate matter*. Degenerate matter found in white dwarfs, neutron stars and black holes. Conventionally this matter in such large astronomical objects has a high temperature (as independent particles!) and a high gravity adding a forcing, confining pressure in a very massive celestial objects. In nature, degenerate matter exists stably (as a big lump) to our knowledge only in large astronomical masses (include their surface where gravitation pressure is zero) and into big nuclei of conventional matter.



Our purpose is to design artificial small masses of synthetic degenerate matter in form of an extremely thin strong thread (fiber, filament, string), round bar (rod), tube, net (dense or non dense weave and mesh size) which can exist at Earth-normal temperatures and pressures. Note that such stabilized degenerate matter in small amounts does not exist in Nature as far as we know. Therefore I have named this matter **AB-Matter**. Just as people now design by the thousands variants of artificial materials (for example, plastics) from usual matter, we soon (historically speaking) shall create many artificial, designer materials by nanotechnology (for example, nanotubes: SWNTs (amchair, zigzag, ahiral, graphen), MWNTs (fullorite, torus, nanobut), nanoribbon (plate), buckyballs (ball), fullerene). Sooner or later we may anticipate development of femtotechnology and create such AB-Matter. Some possible forms of AB-Matter are shown in fig.10. Offered technologies are below. The threads from AB-Matter are stronger by millions of times than normal materials. They can be inserted as reinforcements, into conventional materials, which serve as a matrix, and are thus strengthened by thousands of times (see computation section).

**2. Some offered technologies for producing AB-Matter.** One method of producing AB-Matter may use the technology reminiscent of computer chips (fig.11). One side of closed box 1 is evaporation mask 2. In the other size are located the sources of neutrons, charged nuclear particles (protons, charged nuclei and their connections) and electrons. Sources (guns) of charged particles have accelerators of particles and control their energy and direction. They concentrate (focus) particles, send particles (in beam form) to needed points with needed energy for overcoming the Coulomb barrier. The needed neutrons are received also from nuclear reactions and reflected by the containing walls

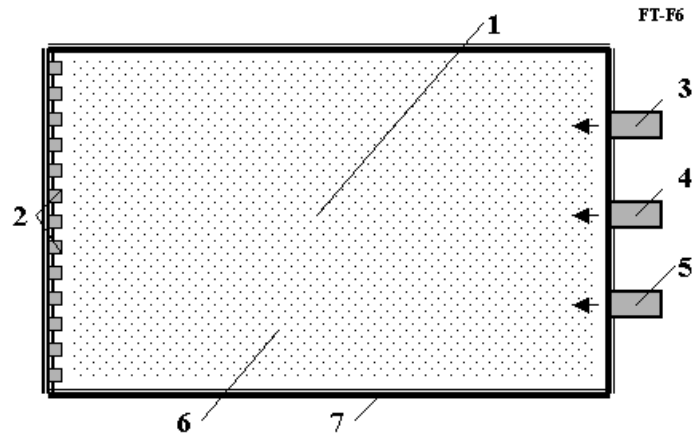


**Fig.10.** Design of AB-Matter from nucleons (neutrons, protons, etc.) and electrons (a) linear one string (monofilament) (fiber, whisker, filament, thread); (b) ingot from four nuclear monofilaments; (c) multi-ingot from nuclear monofilament; (d) string made from protons and neutrons with electrons rotated around monofilament; (e) single wall femto tube (SWFT) fiber with rotated electrons; (f) cross-section of multi wall

femto tube (MWFT) string; (g) cross-section of rod; (h) - single wall femto tube (SWFT) string with electrons inserted into AB-Matter. *Notations:* 1 – nuclear string; 2 - nucleons (neutrons, protons, etc.). 3 – protons; 4 – orbit of electrons; 5 – electrons; 6 – cloud of electrons around tube.

Various other means are under consideration for generation of AB-Matter, what is certain however that once the first small amounts have been achieved, larger and larger amounts will be produced with ever increasing ease. Consider for example, that once we have achieved the ability to make a solid AB-Matter film (a sliced plane through a solid block of AB-matter), and then developed the ability to place holes with precision through it one nucleon wide, a modified extrusion technique may produce AB-Matter strings (thin fiber), by passage of conventional matter in gas, liquid or solid state through the AB-Matter matrix (mask). This would be a ‘femto-die’ as Joseph Friedlander of Shave Shomron, Israel, has labeled it. Re-assembling these strings with perfect precision and alignment would produce more AB-matter film; leaving deliberate gaps would reproduce the ‘holes’ in the initial ‘femto-die’.

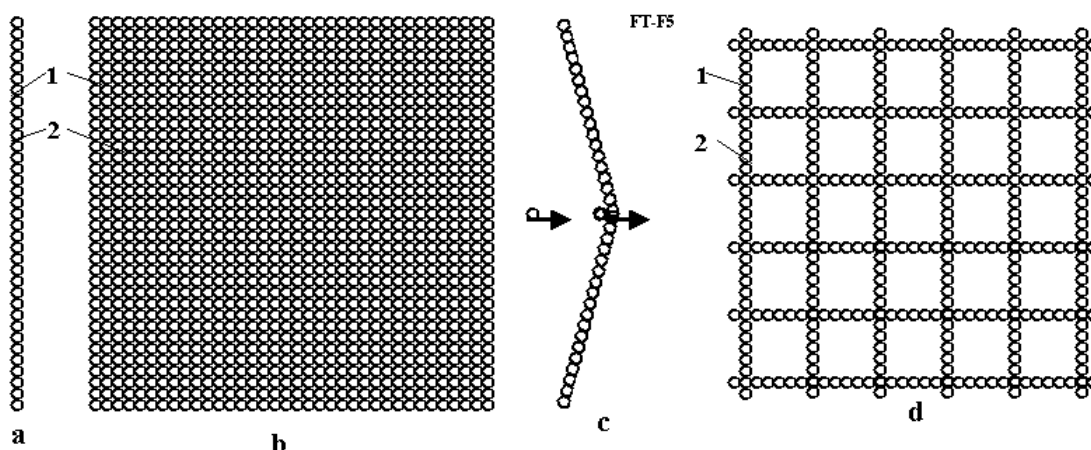
The developing of femtotechnology is easier, in one sense, than the developing of fully controllable nanotechnology because we have only three main particles (protons, neutrons, their ready combination of nuclei  ${}^2\text{D}$ ,  ${}^3\text{T}$ ,  ${}^4\text{He}$ , etc., and electrons) as construction material and developed methods of their energy control, focusing and direction.



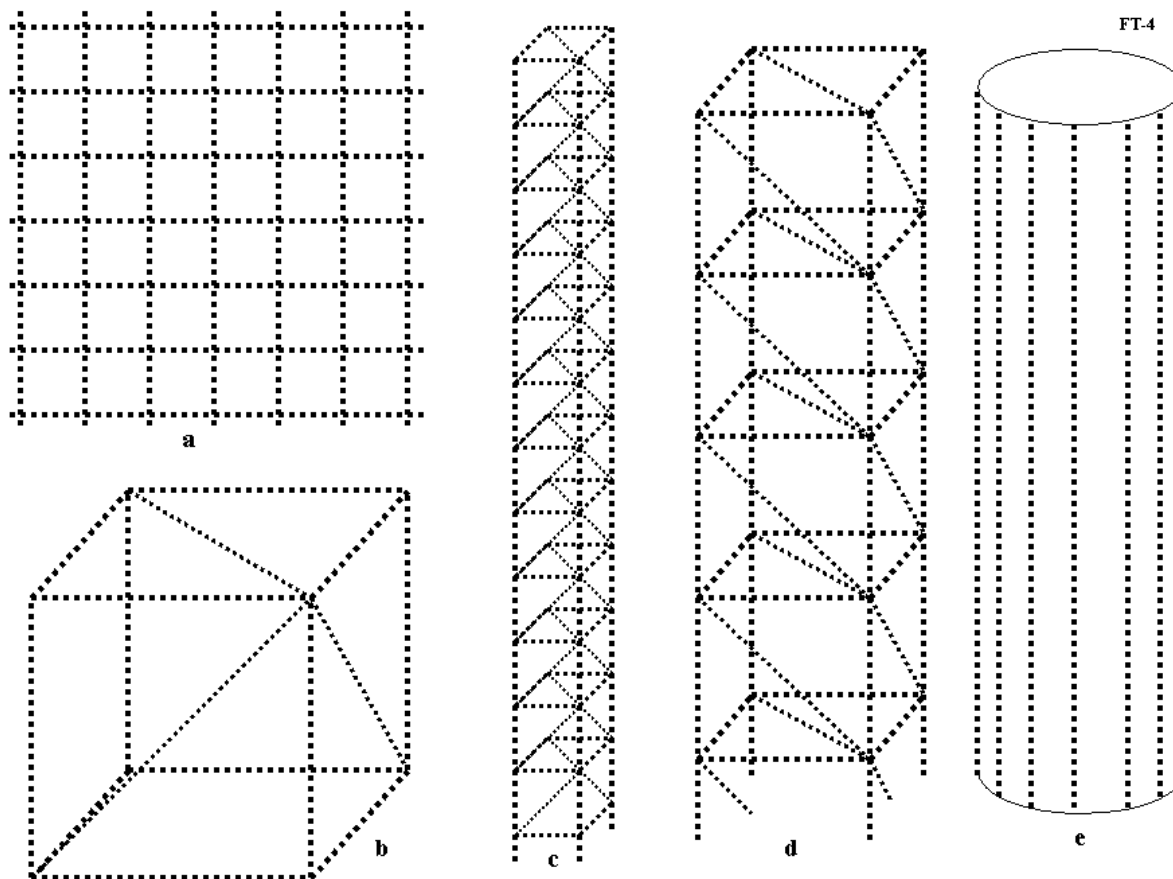
**Fig.11.** Conceptual diagram for installation producing AB-Matter. Notations: 1 – installation; 2 –AB-Matter (an extremely thin thread, round bar, rod, tube, net) and form mask; 3 – neutron source; 4 – source of charged particles (protons, charged nuclei), accelerator of charged particle, throttle control, beam control; 5 - source of electrons, accelerator of electrons, throttle control, beam control; 6 – cloud of particles; 7 – walls reflect the neutrons and utilize the nuclear energy.

**3. Using the AB-Matter** (fig.12). The simplest use of AB-Matter is strengthening and reinforcing conventional material by AB-Matter fiber. As it is shown in the ‘Computation’ section, AB-Matter fiber is stronger (has a gigantic ultimate tensile stress) than conventional material by a factor of millions of times, can endure millions degrees of temperature, don’t accept any attacking chemical reactions. We can insert (for example, by casting around the reinforcement) AB-Matter fiber (or net) into steel, aluminum, plastic and the resultant matrix of conventional material increases in strength by thousands of times—if precautions are taken that the reinforcement stays put! Because of the extreme strength disparity design tricks must be used to assure that the fibers stay ‘rooted’. The matrix form of conventional artificial fiber reinforcement is used widely in current technology. This increases the tensile stress resistance of the reinforced matrix matter by typically 2 – 4 times. Engineers dream about a nanotube reinforcement of conventional matrix materials which might increase the tensile stress by 10 – 20 times, but nanotubes are very expensive and researchers cannot decrease its cost to acceptable values yet despite years of effort.

Another way is using a construct of AB-Matter as a continuous film or net (fig. 13).



**Fig.12.** Thin film from nuclear matter. (a) cross-section of a matter film from single strings (side view); (b) continuous film from nuclear matter; (c) AB film under blow from conventional molecular matter; (d) – net from single strings. Notations: 1 – nucleons; 2 – electrons inserted into AB-Matter; 3 – conventional atom.



**Fig.13.** Structures from nuclear strings. (a) nuclear net (netting, gauze); (b) primary cube from matter string; (c) primary column from nuclear string; (d) large column where elements are made from primary columns; (e) tubes from matter string or matter columns.

These forms of AB-Matter have such miraculous properties as invisibility, superconductivity, zero friction, etc. The ultimate in camouflage, installations of a veritable Invisible World can be built from certain forms of AB-Matter with the possibility of being also interpenetrable, literally allowing ghost-

like passage through an apparently solid wall. Or the AB-Matter net (of different construction) can be designed as an impenetrable wall that even hugely destructive weapons cannot penetrate.

The AB-Matter film and net may be used for energy storage which can store up huge energy intensities and used also as rocket engines with gigantic impulse or weapon or absolute armor (see computation and application sections). Note that in the case of absolute armor, safeguards must be in place against buffering sudden accelerations; g-force shocks can kill even though nothing penetrates the armor!

The AB-Matter net (which can be designed to be gas-impermeable) may be used for inflatable construction of such strength and lightness as to be able to suspend the weight of a city over a vast span the width of a sea. AB-Matter may also be used for cubic or tower solid construction as it is shown in fig.13.

## Estimation and Computation of Properties of AB-Matter

### 1. Strength of AB-Matter.

*Strength (tensile stress) of single string (AB-Matter monofilament).* The average connection energy of two nucleons is

$$1 \text{ eV} = 1.6 \times 10^{-19} \text{ J}, \quad E = 8 \text{ MeV} = 12.8 \times 10^{-13} \text{ J}. \quad (1)$$

The average effective distance of the strong force is about  $l = 2 \text{ fm} = 2 \times 10^{-15} \text{ m}$  ( $1 \text{ fm} = 10^{-15} \text{ m}$ ). The average connection force  $F$  the single thread is about

$$F_l = E/l = 6.4 \times 10^2 \text{ N}. \quad (2)$$

This is worth your attention: a thread having diameter *100 thousand times less than an atom's diameter* can suspend a weight nearly of human mass. The man may be suspended this invisible and permeable thread(s) and people will not understand how one fly.

Specific ultimate tensile stress of single string for cross-section area  $s = 2 \times 2 = 4 \text{ fm}^2 = 4 \times 10^{-30} \text{ m}^2$  is

$$\sigma = F/s = 1.6 \times 10^{32} \text{ N/m}^2. \quad (3)$$

Compressive stress for  $E = 30 \text{ MeV}$  and  $l = 0.4 \text{ fm}$  (fig.1) is

$$\sigma = E/sl = 3 \times 10^{33} \text{ N/m}^2. \quad (4)$$

The Young's modulus of tensile stress for elongation of break  $\varepsilon = 1$  is

$$I = \sigma/\varepsilon = 1.6 \times 10^{32} \text{ N/m}^2. \quad (5)$$

The Young's modulus of compressive stress for  $\varepsilon = 0.4$  is

$$I = \sigma/\varepsilon = 7.5 \times 10^{33} \text{ N/m}^2. \quad (6)$$

*Comparison:* Stainless steel has a value of  $\sigma = (0.65 - 1) \times 10^9 \text{ N/m}^2$ ,  $I = 2 \times 10^{11} \text{ N/m}^2$ . Nanotubes has  $\sigma = (1.4 \div 5) \times 10^{10} \text{ N/m}^2$ ,  $I = 8 \times 10^{11} \text{ N/m}^2$ . That means AB-Matter is stronger by a factor of  $10^{23}$  times than steel (by 100 thousands billion by billions times!) and by  $10^{22}$  times than nanotubes (by 10 thousand billion by billions times!). Young's modulus, and the elastic modulus also are billions of times more than steel and elongation is tens times better than the elongation of steel.

Strength (average tensile force) of one m thin (one layer, 1 fm) film (1 m compact net) from single strings with step size of grid  $l = 2 \text{ fm} = 2 \times 10^{-15} \text{ m}$  is

$$F = F_l / l = 3.2 \times 10^{17} \text{ N/m} = 3.2 \times 10^{13} \text{ tons/m}. \quad (7)$$

Strength (average tensile force) of net from single string with step (mesh) size  $l = 10^{-10} \text{ m}$  (less than a molecule size of conventional matter) which does not pass the any usual gas, liquids or solid (an impermeable net, essentially a film to ordinary matter)

$$F = F_l / l = 6.4 \times 10^{12} \text{ N/m} = 6.4 \times 10^8 \text{ tons/m}. \quad (8)$$

That means one meter of very thin (1 fm) net can suspend *100 millions tons of load*.

The tensile stress of a permeable net (it will be considered later) having  $l = 10^{-7} \text{ m}$  is

$$F = F_l / l = 6.4 \times 10^9 \text{ N/m} = 6.4 \times 10^5 \text{ tons/m}. \quad (9)$$

### 2. Specific density and specific strength of AB-Matter.

The mass of 1 m of single string (AB-Matter. Monofilament) is

$$M_l = m/l = 1.67 \times 10^{-27} / (2 \times 10^{-15}) = 8.35 \times 10^{-13} \text{ kg.} \quad (10)$$

where  $m = 1.67 \times 10^{-27}$  kg is mass of one nucleon;  $l = 2 \times 10^{-15}$  is distance between nucleons, m., the volume of 1 m one string is  $v = 10^{-30} \text{ m}^3$ . That means the specific density of AB-Matter string and compact net is

$$d = \gamma = M_l/v = 8.35 \times 10^{17} \text{ kg/m}^3. \quad (11)$$

That is very high (nuclear) specific density. But the total mass is nothing to be afraid of since, the dimensions of AB-Matter string, film and net are very small and mass of them are:

a) mass of string  $M_l = 8.35 \times 10^{-13} \text{ kg}$  (see (10)), (12)

b) mass of 1 m<sup>2</sup> solid film  $M_f = M_l/l = 4.17 \times 10^2 \text{ kg}$ ,  $l = 2 \times 10^{-15}$ . (13)

c) mass of 1 m<sup>2</sup> impenetrable net  $M_i = M_l/l = 8.35 \times 10^{-3} \text{ kg}$ ,  $l = 10^{-10} \text{ m}$ , (14)

d) mass of 1 m<sup>2</sup> permeable net  $M_p = M_l/l = 8.35 \times 10^{-6} \text{ kg}$ ,  $l = 10^{-7} \text{ m}$ . (15)

As you see the fiber, nets from AB-Matter have very high strength and very small mass. To provide an absolute heat shield for the Space Shuttle Orbiter that could withstand reentries dozens of times worse than today would take only ~100 kilograms of mass for 1105 square meters of surface and the offsetting supports.

The specific strength coefficient of AB-Matter-- very important in aerospace-- [3]-[5] is  $k = \sigma/d = 1.6 \times 10^{32} / 8.35 \times 10^{17} = 1.9 \times 10^{14} \text{ (m/s)}^2 < c^2 = (3 \times 10^8)^2 = 9 \times 10^{16} \text{ (m/s)}^2$ . (16)

This coefficient from conventional high strong fiber has value about  $k = (1 - 6) \times 10^9$  [3]-[6]. AB-Matter is 10 million times stronger.

The specific mass and volume density of energy with AB-Matter are

$$E_v = E/v = 1.6 \times 10^{32} \text{ J/m}^3, \quad E_m = E/m_p = 7.66 \times 10^{14} \text{ J/kg}. \quad (17)$$

Here  $E = 12.8 \times 10^{-13} \text{ J}$  is (1),  $m_p = 1.67 \times 10^{-27} \text{ kg}$  is nucleon mass, kg,  $v = 8 \times 10^{-45} \text{ m}^3$  is volume of one nucleon. The average specific pressure may reach

$$p = F_l/s = 12.8 \times 10^{-13} / 4 \times 10^{-30} = 3.2 \times 10^{-27} \text{ N/m}^2.$$

### 3. Failure temperature of AB-Matter and suitability for thermonuclear reactors.

The strong nuclear force is very powerful. That means the outer temperature which must to be reached to destroy the AB fiber, film or net is  $T_e = 6 \text{ MeV}$ . If we transfer this temperature in Kelvin degrees we get

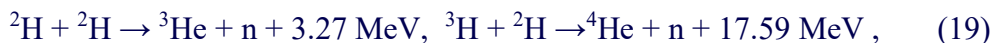
$$T_k = 1.16 \times 10^4 T_e = 7 \times 10^{10} \text{ K.} \quad (18)$$

That temperature is 10 thousands millions degrees. It is about 50 - 100 times more than temperature in a fusion nuclear reactor. The size and design of the fusion reactor may be small and simple (for example, without big superconductive magnets, cryogenics, etc). We can add the AB matter has zero heat/thermal conductivity (see later) and it cannot cool the nuclear plasma. This temperature is enough for nuclear reaction of the cheap nuclear fuel, for example, D + D. The AB matter may be used in a high efficiency rocket and jet engines, in a hypersonic aircraft and so on.

No even in theory can conventional materials have this fantastic thermal resistance!

### 4. Energy generated by production of AB-Matter.

Getting of AB-matter produces a large amount of nuclear energy. That energy is more than the best thermonuclear fusion reaction produces. Joining of each nucleon produces 8 MeV energy, when joining the deuterium D and tritium T (2+3=5 nucleolus) produced only 17.5 MeV (3.6 MeV for every nucleon). If we use the ready blocks of nucleons as the D=<sup>2</sup>H, T=<sup>3</sup>H, <sup>4</sup>He, etc., the produced energy decreases. Using the ready nucleus blocks may be necessary because these reactions create the neutrons (n). For example:



which may be useful for producing the needed AB-Matter.

Using the ready blocks of nucleons decreases the energy getting in AB-Matter production but that



decreases also the cost of needed material and enormously simplifies the technology.

A small part (0.7 MeV) of this needed energy will be spent to overcome the Coulomb barrier when the proton joins to proton. Connection of neutrons to neutron or proton does not request this energy (as there is no repulsion of charges). It should be no problem for current technology to accelerate the protons for energy 0.7 MeV.

For example, compute the energy in production of  $m = 1$  gram = 0.001 kg of AB-Matter.

$$E_{1g} = E_1 m / m_p = 7.66 \times 10^{11} \text{ J/g} . \quad (20)$$

Here  $E_1 = 8 \text{ MeV} = 12.8 \times 10^{-13} \text{ J}$  – energy produced for joining 1 nucleon,  $m_p = 1.67 \times 10^{-27} \text{ kg}$  is mass of nucleon.

One kg of gasoline (benzene) produces 44 MJ/kg energy. That means that 1 g of AB-Matter requires the equivalent energy of 17.4 tons of benzene.

**5. Super-dielectric strength of AB-Matter film.** Dielectric strength equals

$$E_d = E/l = 8 \text{ MV}/10^{-15} \text{ m} = 8 \times 10^{15} \text{ MV/m} . \quad (21)$$

The best conventional material has dielectric strength of only 680 MV/m [4].

**6. AB-Matter with orbiting electrons or immersed in electron cloud.** We considered early the AB-Matter which contains the electrons within its' own string, film or net. The strong nuclear force keeps the electron (as any conventional matter particle would) in its sphere of influence. But another method of interaction and compensation of electric charges is possible– rotation of electrons around AB-Matter string (or other linear member) or immersing the AB-Matter string (or other linear member, or AB-Matter net --) in a sea of electrons or negative charged atoms (ions). The first case is shown in fig. 3d,e,g , the second case is shown in fig. 3f.

The first case looks like an atom of conventional matter having the orbiting electron around the nucleus. However our case has a principal difference from conventional matter. In normal matter the electron orbits around the nucleus as a POINT. In our case it orbits around the charged nuclear material (AB-Matter) LINE (some form of linear member from AB-Matter). That gives a very important difference in electrostatic force acting on the electron. In conventional cases (normal molecular matter) the electrostatic force decreases as  $1/r^2$ , in our AB-Matter case the electrostatic force decreases as  $1/r$ . The interesting result (see below) is that the electron orbit in AB-Matter does follow the usual speed relationship to radius. The proof is below:

$$\frac{mV^2}{r} = eE, \quad E = k \frac{2\tau}{r}, \quad mV^2 = 2k\tau e, \quad V = \sqrt{\frac{2ke\tau}{m}} = \sqrt{N_p} e \sqrt{\frac{2k}{m}} = 22.4 \sqrt{N_p}, \quad (22)$$

where  $m = m_e = 9.11 \times 10^{-31} \text{ kg}$ ;  $V$  – electron speed, m/s;  $r$  is radius of electron orbit, m;  $\tau$  is charge density in 1 m of single string, C/m;  $E$  is electrostatic intensity, A/m or N/C;  $k = 9 \times 10^9 \text{ Nm}^2/\text{C}^2$  is electrostatic constant,  $e = 1.6 \times 10^{-19} \text{ C}$  is charge of electron, C;  $N_p$  is number of proton in 1 m of single string, 1/m. As you see from last equation (22) the electron speed is not relative to radius. The real speed will be significantly less than given equation (22) because the other electrons block the charge of the rest of the string.

The total charge of the system is zero. Therefore we can put  $N_p = 1$  (every electron in orbit is kept by only one proton in string). From last equation (22) we find  $V = 22.4 \text{ m/s}$ . That means the electron speed carries only a very small energy.

In the second case the AB-Matter (string girder) can swim in a cloud (sea) of electrons. That case occurs in metals of conventional matter. But a lattice of metallic ions fills the volume of conventional metal giving drag to electron flow (causing electrical resistance).

The stringers and plate nets of AB-Matter can locate along the direction of electric flow. They constitute only a relatively tiny volume and will produce very small electric resistance. That means the AB-Matter may be quasi-super-conductivity or super-conductivity.

The electrons rotate around an AB-Matter string repel one from other. The tensile force from them is

$$F = k \frac{e^2}{d^2} \left( 1 + \frac{1}{2^2} + \frac{1}{3^2} + \dots + \frac{1}{n^2} + \dots \right) = \frac{\pi^2 k e^2}{6 d^2} = 1.476 \cdot 10^{10} \frac{e^2}{d^2} . \quad (23)$$

For distance  $d = 2 \times 10^{-15}$  m the force equals  $F = 10.5$  N. This force keeps the string and net in unfolded stable form.

## Some Properties of AB-Matter

We spoke about the *fantastic tensile and compressive strength, rigidity, hardness, specific strength, thermal (temperature) durability, thermal shock, and big elongation of* AB-Matter.

Short note about other miraculous AB-Matter properties:

1. *Zero heat/thermal capacity.* That follows because the mass of nucleons (AB-Matter string, film, net) is large in comparison with mass single atom or molecule and nucleons in AB-Matter have a very strong connection one to other. Conventional atoms and molecules cannot pass their paltry energy to AB-Matter! That would be equivalent to moving a huge dry-dock door of steel by impacting it with very light table tennis balls.

2. *Zero heat/thermal conductivity.* (See above).

3. *Absolute chemical stability. No corrosion, material fatigue. Infinity of lifetime.* All chemical reactions are acted through ORBITAL electron of atoms. The AB-Matter does not have orbital electrons (special cases will be considered later on). Nucleons cannot combine with usual atoms having electrons. In particular, the AB-Matter has *absolute corrosion resistance. No fatigue of material* because in conventional material fatigue is result of splits between material crystals. No crystals in AB-Matter. That means AB-Matter has lifetime equal to the lifetime of neutrons themselves. Finally a container for the universal solvent!

4. *Super-transparency, invisibility of special AB-Matter-nets.* An AB-Matter net having a step distance (mesh size) between strings or monofilaments of more than  $100 \text{ fm} = 10^{-13} \text{ m}$  will pass visible light having the wave length  $(400 - 800) \times 10^{-9} \text{ m}$ . You can make cars, aircraft, and space ships from such a permeable (for visible light) AB-Matter net and you will see a man (who is made from conventional matter) apparently sitting on nothing, traveling with high speed in atmosphere or space without visible means of support or any visible vehicle!

5. *Impenetrability for gas, liquids, and solid bodies.* When the AB-Matter net has a step size between strings of less than atomic size of  $10^{-10} \text{ m}$ , it became impenetrable for conventional matter. Simultaneously it may be invisible for people and have gigantic strength. The AB-Matter net may –as armor--protect from gun, cannon shells and missiles.

6. *Super-impenetrability for radiation.* If the cell size of the AB-Matter net will be less than a wave length of a given radiation, the AB-Matter net does not pass this radiation. Because this cell size may be very small, AB net is perfect protection from any radiation up to soft gamma radiation (include radiation from nuclear bomb).

7. *Full reflectivity (super-reflectivity).* If the cell size of an AB-Matter net will be less than a wavelength of a given radiation, the AB-Matter net will then fully reflect this radiation. With perfect reflection and perfect impenetrability remarkable optical systems are possible. A Fresnel like lens might also be constructible of AB-Matter.

8. *Permeable property (ghost-like intangibility power; super-passing capacity).* The AB-Matter net from single strings having mesh size between strings of more than  $100 \text{ nm} = 10^{-11} \text{ m}$  will pass the atoms and molecules through itself because the diameter of the single string ( $2 \times 10^{-15} \text{ m}$ ) is 100 thousand times less then diameter of atom ( $3 \times 10^{-10} \text{ m}$ ). That means that specifically engineered constructions from AB-Matter can be built on the Earth, but people will not see and feel them. The power to phase through walls, vaults, and barriers has occasionally been portrayed in science fiction

but here is a real life possibility of it happening.

**9. Zero friction.** If the AB-Matter net has a mesh size distance between strings equals or less to the atom ( $3 \times 10^{-10}$  m), it has an ideal flat surface. That means the mechanical friction may be zero. It is very important for aircraft, sea ships and vehicles because about 90% of its energy they spend in friction. Such a perfect surface would be of vast value in optics, nanotech molecular assembly and prototyping, physics labs, etc.

**10. Super or quasi-super electric conductivity at any temperature.** As it is shown in previous section the AB-Matter string can have outer electrons in an arrangement similar to the electronic cloud into metal. But AB-Matter strings (threads) can be located along the direction of the electric intensity and they will not resist the electron flow. That means the electric resistance will be zero or very small.

**11. High dielectric strength** (see (21)).

AB-Matter may be used for devices to produce high magnetic intensity.

## Applications and new systems in Aerospace and aviation

The applications of the AB-Matter are encyclopedic in scope. This matter will create revolutions in many fields of human activity. We show only non-usual applications in aerospace, aviation that come to mind, and by no means all of these.

### 1. Storage of gigantic energy.

As it is shown in [3]-[7], the energy saved by flywheel equals the special mass density of material (17). As you see that is a gigantic value of stored energy because of the extreme values afforded by the strong nuclear force. Car having a pair of 1 gram counterspun fly-wheels (2 grams total) (20) charged at the factory can run all its life without benzene. Aircraft or sea ships having 100 gram (two 50 gram counterspun fly-wheels) can fly or swim all its life without additional fuel. The offered flywheel storage can has zero friction and indefinite energy storage time.

### 2. New propulsion system of space ship.

The most important characteristic of rocket engine is specific impulse (speed of gas or other material flow out from propulsion system). Let us compute the speed of a part of fly-wheel ejected from the offered rocket system

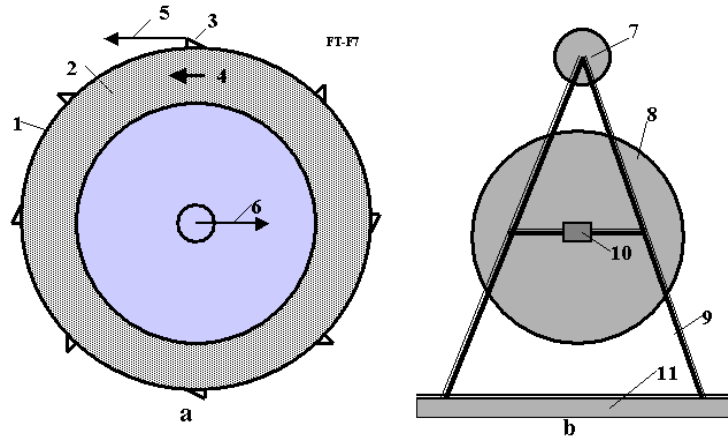
$$\frac{mV^2}{2} = E, \quad V = \sqrt{\frac{2E}{m}} = 3.9 \cdot 10^7 \text{ m/s.} \quad (24)$$

Here  $V$  is speed of nucleon, m/s;  $E = 12.8 \times 10^{-13}$  J (1) is energy of one nucleon, J;  $m = 1.67 \times 10^{-27}$  kg is mass of one nucleon, kg. The value (24) is about 13% of light speed.

The chemical rocket engine has specific impulse about 3700 m/s. That value is 10 thousand times less. The electric rocket system has a high specific impulse but requires a powerful compact and light source of energy. In the offered rocket engine the energy is saved in the flywheel. The current projects of a nuclear rocket are very complex, heavy, and dangerous for men (gamma and neutron radiation) and have specific impulse of thousand of times less (24). The offered AB-Matter rocket engine may be very small and produced any rocket thrust in any moment in any direction.

The offered flywheel rocket engine used the AB-matter is presented in fig.7a. That is flywheel made from AB-matter. It has a nozzle 3 having control of exit mass. The control allows to exit of work mass in given moment and in given position of flywheel. The flywheel rotates high speed and the exhaust mass leave the rocket engine with same speed when the nozzle is open. In result the engine has thrust 6. As exhaust mass may be used any mass: liquid (for example, water), sand, small stones and other suitable planet or space material (mass). The energy needed for engine and space ship is saved in the revolving flywheel. This energy may be received at started planet or from space ship engine.





**Fig. 14.** Schema of new rocket and propulsion system. (a) Propulsion system from AB matter and storage energy. (b) Rocket with offered propulsion system.

Notations: 1 – cover (flywheel) from AB-matter; 2 – any work mass; 3 – nozzle with control of exit mass; 4 – direction of rotation; 5 – direction of exhaust mass; 6 – thrust; 7 – space ship; 8 – offered propulsion system; 9 – undercarriage; 10 – rotary mechanism; 11 – planet surface.

The rocket used the suggested engine is shown in fig, 7b. That has a cabin 7, the offered propulsion system 8, undercarriage 9 and rotary mechanism 10 for turning the ship in need position.

Let us to estimate the possibility of offered rocket. Notate, the relation of the exhaust mass to AM-matter cover mass of flywheel are taken  $a = 10$ , the safety (strength) factor  $b = 4$ . About 20% of space ship is payload and construction and 80% is the exhaust mass. Then exhaust speed of throw away mass and receiving speed by space ship are:

$$V = \sqrt{\frac{k}{ab}} = 2.12 \cdot 10^6 \text{ m/s}, \quad m_s V_s = mV, \quad V_s = \frac{m}{m_s} V = \frac{0.8}{0.2} \cdot 2.12 \cdot 10^6 = 8.48 \cdot 10^6 \text{ m/s}, \quad (25)$$

where  $V$  speed of exhausted mass, m/s;  $k = \sigma/d = 1.9 \times 10^{14} \text{ (m/s)}^2$  is strength coefficient (16);  $m_s$  is final mass of rocket, kg;  $V_s = 8480 \text{ km/s}$  is final speed of rocket, m/s;  $m$  is throw off mass, kg.

Let us to remind the escape speed of planets.

**Table 1.** Some data and escape speed from planets of Solar system.

Sun and planets	Distance from Sun $10^6 \text{ km}$	Gravity $\text{m/s}^2$	Escape speed $\text{km/s}$	Planets	Distance from Sun $10^6 \text{ km}$	Gravity $\text{m/s}^2$	Escape speed $\text{km/s}$
Sun	-	274	617.7	Jupiter	777.8	23.01	60.2
Mercury	57.9	3.72	4.15	Saturn	1326	9.14	36.2
Venus	108.1	8,69	10.25	Uranus	2868	9.67	21.4
Earth	149.5	9.78	11.19	Neptune	4494	15	23.4
Mars	227.8	3.72	5.09	Moon	0.384*	1.62	2.36

\* From Earth.

The Table 1 allows estimating how many times the offered rocket can flight to other planets using one refueling (re-energy). These numbers are (with returning back to Earth): to Moon - 420 times, to Mars - 280 times, to Venus – 200 times, to Jupiter 96 times and out of Solar system 7 times.



**Fig.15.** Possible form of space ship from AB matter.

### 3. Super-weapon.

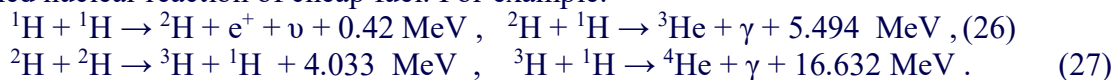
Capability of an AB-Matter flywheel to spin up and ejection matter at huge speed (24)-(25) may be used as a long distance super-weapon.

### 4. Super-armor from conventional weapons.

The value (24) gives the need speed for break through (perforation) of a shield of AB-Matter. No weapon which can give this speed exists at the present time. Remain, the AB-Matter may be radiation impermeable. That means AB-Matter can protect from a nuclear bomb and laser weapon.

### 5. Simple thermonuclear reactor.

The AB-Matter film may be used as the wall of a simple thermonuclear reactor. The AB-Matter film allows a direct 100% hit by the accelerated nuclei to stationary nuclei located into film. You get a controlled nuclear reaction of cheap fuel. For example:

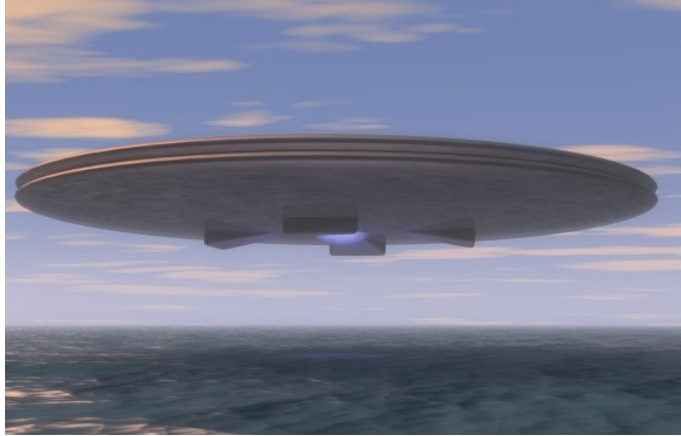


Here  $e^+$  is electron;  $\nu$  is neutrino;  $\gamma$  is  $\gamma$ -quantum, photon ( $\gamma$ -radiation);  ${}^1\text{H} = p$  is proton;  ${}^2\text{H} = D$  is deuterium;  ${}^3\text{H} = T$  is tritium; He is helium.

In conventional thermonuclear reactor the probability of a hit by the accelerated (or highly heated) nuclei to other nuclei is trifling. The accelerated particles, which run through ghostlike ATOMS and lose the energy, need therefore to be sent through to repeated collisions each of which loses energy until the one that hits and generates energy. The winner must pay for all the losers. That way we need big, very complex, and expensive high temperature conventional thermonuclear reactors. They are so nearly unbuildable because ordinary matter literally cannot take the reactions they are designed to contain, and therefore special tricks must be used to sidestep this, and the reactions are so improbable that again special tricks are required. Here, every shot is a hit and the material can endure every consequence of that hit. A good vacuum system and a means of getting power and isotopes in and out are the main problems, and by no means insuperable ones. Using the AB-Matter we can design a micro-thermonuclear AB reactor.

### 6. High efficiency rocket, jet and piston aviation engines.

The efficiency conventional jet and rocket engines are very limited by the temperature and safety limits of conventional matter (2000°K). If we will design the rotor blades (in jet engine), combustion chamber (in rocket and piston engines) from AB-Matter, we radically improve their capacities and simplify their construction (for example, no necessary cooling system!).



**Fig.16.** Possible form of aircraft from AB matter

### 7. Hypersonic aircraft.

The friction and heat which attacks conventional materials for hypersonic aircraft limits their speed. Using the AB-Matter deletes this problem. Many designs for aerospace planes could capture oxygen in flight, saving hauling oxidizer and carrying fuel alone—enabling airliner type geometries and payloads since the weight of the oxidizer and the tanks needed to hold it, and the airframe strengths required escalate the design and cascade through it until conventional materials today cannot build a single stage to orbit or antipodes aerospace plane. But that would be quite possible with AB-Matter.

### 8. Increasing efficiency of a conventional aviation and transport vehicles.

AB-Matter does not experience friction. The air drag in aviation is produced up 90% by air friction on aircraft surface. Using AB-Matter will make jump in flight characteristics of aircraft and other transport vehicles (including sea ships and cars).

### 9. Improving capabilities of all machines.

Appearance new high strength and high temperature AB-Matter will produce jump, technology revolution in machine and power industries.

### 10. Computer and computer memory.

The AB-Matter film allows to write in  $1 \text{ cm}^2$   $N = 1/(4 \times 10^{-26}) = 2.5 \times 10^{25}$  1/cm<sup>2</sup> bits information. The current 45 nanometer technology allows to write only  $N = 2.5 \times 10^{14}$  1/cm<sup>2</sup> bit. That means the main chip and memory of computer based in AB-Matter film may be a billion times smaller and presumably thousands of times faster (based on the lesser distance signals must travel).

The reader can imagine useful application of AB-Matter in any field he is familiar with.

## Discussion

### 1. Pauli exclusion principle and Heisenberg Uncertainty Principle. General Question of Stability.

The reader may have questions about compatibility of the Pauli exclusion principle and Heisenberg Uncertainty Principle with AB-Matter. The uncertainty principle is

$$\Delta p \Delta x \geq \hbar / 2. \quad (27)$$

where  $\Delta p = mV$  is momentum of particle, kg·m/s;  $m$  is mass particles, kg;  $V$  is speed particles, m/s;  $\Delta x$  is distance between particles, m;  $\hbar = 6.6262 \times 10^{-34} / 2\pi$  is Planck's constant.

Pauli states that no two identical fermions may occupy the same quantum state *simultaneously*. A more rigorous statement of this principle is that, for two identical fermions, the total wave function is anti-symmetric. For electrons in a single atom, it states that no two electrons can have the same four quantum numbers, that is, if particles characteristics  $n$ ,  $l$ , and  $m_l$  are the same,  $m_s$  must be different such that the electrons have opposite spins.

The uncertainty principle gives a high uncertainty of  $\Delta p$  for nucleons and very high uncertainty for electrons into AB-Matter. But high density matter (of the same order as our suggested AB-Matter) EXISTS in the form of nuclei of conventional matter and on neutron stars. That is an important proof - this matter exists. Some may question its' ability to stay in a superdense state passively. Some may doubt its' stability free of the fierce gravitation of neutron stars (natural degenerate matter) or outside the confines of the nucleus. But there are reasons, not all stated here, to suppose that it might be so stable under normal conditions.

One proof was provided by Freeman Dyson [11] and Andrew Lenard in 1967, who considered the balance of attractive (electron-nuclear) and repulsive (electron-electron and nuclear-nuclear) forces and showed that ordinary matter would collapse and occupy a much smaller volume without the Pauli principle.

Certainly, however this very question of stability will be a key focus of any detailed probe into the possibilities of AB-Matter.

**2. Micro-World from AB-Matter: An Amusing Thought-Experiment.** AB-Matter may have  $10^{15}$  times more particles in a given volume than a single atom. A human being, man made from conventional matter, contains about  $5 \times 10^{26}$  molecules. That means that 200 'femto-beings' of equal complexity from AB-Matter (having same number of components) could be located in the volume of one microbe having size  $10 \mu = 10^{-5}$  m. If this proved possible, we could not see them, they could not see us in terms of direct sensory input. Because of the wavelength of light it is questionable what they could learn of the observable macro-Universe. The implications, for transhuman scenarios, compact interstellar (microbe sized!) payloads, uploading and other such scenarios are profound. It is worth recalling that a single house and garden required to support a single conventional matter human is, for AB-Matter 'femto-beings', equivalent in relative vastness as the extended Solar system is for us. If such a future form could be created and minds 'uploaded' to it, the future theoretical population, knowledge base, and scholarly and knowledge-industries output of even a single planet so populated could rival that of a theoretical Kardashev Type III galactic civilization!

*Note:* The same idea may hypothetically be developed for *atto* ( $10^{-18}$  m), *zepto* ( $10^{-21}$  m), and *yocto* ( $10^{-24}$  m) technologies. It is known that nucleons consist of quarks. Unfortunately, we do not know yet about size, forces and interactions between quark and cannot therefore make predictions about atto or zepto-technology. One theory posits that the quark consists of preons. But we do not know anything about preons. The possibility alone must intrigue us for now. Where does it all end?

## Conclusion

The author offers a design for a new form of nuclear matter from nucleons (neutrons, protons), electrons, and other nuclear particles. He shows that the new AB-Matter has most extraordinary properties (for example, (in varying circumstances) remarkable tensile strength, stiffness, hardness, critical temperature, superconductivity, super-transparency, ghostlike ability to pass through matter, zero friction, etc.), which are millions of times better than corresponded properties of conventional molecular matter. He shows how to design aircraft, ships, transportation, thermonuclear reactors, and constructions, and so on from this new nuclear matter. These vehicles will have correspondingly amazing possibilities (invisibility, passing through any walls and amour, protection from nuclear

bombs and any radiation, etc).

People may think this fantasy. But fifteen years ago most people and many scientists thought – nanotechnology is fantasy. Now many groups and industrial labs, even startups, spend hundreds of millions of dollars for development of nanotechnological-range products (precise chemistry, patterned atoms, catalysts, metamaterials, etc) and we have nanotubes (a new material which does not exist in Nature!) and other achievements beginning to come out of the pipeline in prospect. Nanotubes are stronger than steel by a hundred times—surely an amazement to a 19<sup>th</sup> Century observer if he could behold them.

Nanotechnology, in near term prospect, operates with objects (molecules and atoms) having the size in nanometer ( $10^{-9}$  m). The author here outlines perhaps more distant operations with objects (nuclei) having size in the femtometer range, ( $10^{-15}$  m, millions of times less smaller than the nanometer scale). The name of this new technology is femtotechnology.

I want to explain the main thrust of this by analogy. Assume we live some thousands of years ago in a great river valley where there are no stones for building and only poor timber. In nature we notice that there are many types of clay (nuclei of atom—types of element). One man offers to people to make from clay bricks (AB-Matter) and build from these bricks a fantastic array of desirable structures too complex to make from naturally occurring mounds of mud. The bricks enable by increased precision and strength things impossible before. A new level of human civilization begins.

I call upon scientists and the technical community to research and develop femtotechnology. I think we can reach in this field progress more quickly than in the further prospects of nanotechnology, because we have fewer (only 3) initial components (proton, neutron, electron) and interaction between them is well-known (3 main forces: strong, weak, electrostatic). The different conventional atoms number about 100, most common molecules are tens thousands and interactions between them are very complex (e.g. Van der Waals force).

It may be however, that nano and femto technology enable each other as well, as tiny bits of AB-Matter would be marvellous tools for nanomechanical systems to wield to obtain effects unimaginable otherwise.

What time horizon might we face in this quest? The physicist Richard Feynman offered his idea to design artificial matter from atoms and molecules at an American Physical Society meeting at Caltech on December 29, 1959. But only in the last 15 years we have initial progress in nanotechnology. On the other hand progress is becoming swifter as more and better tools become common and as the technical community grows.

Now are in the position of trying to progress from the ancient ‘telega’ haywagon of rural Russia (in analogy, conventional matter composites) to a ‘luxury sport coupe’ (advanced tailored nanomaterials). The author suggests we have little to lose and literal worlds to gain by simultaneously researching how to leap from ‘telega’ to ‘hypersonic space plane’. (Femotech materials and technologies, enabling all the wonders outlined here).

## REFERENCES

(The reader may find some of related articles at the author’s web page <http://Bolonkin.narod.ru/p65.htm>; <http://arxiv.org>, <http://www.scribd.com> search “Bolonkin”; <http://aiaa.org> search “Bolonkin”; and in the author’s books: “*Non-Rocket Space Launch and Flight*”, Elsevier, London, 2006, 488 pages; “*New Concepts, Ideas, Innovations in Aerospace, Technology and Human Science*”, NOVA, 2008, 502 pages and “*Macro-Projects: Environment and Technology*”, NOVA 2009, 536 pages).

1. Bolonkin A.A., (1983a) Method of a Keeping of a Neutral Plasma and Installation for it. Russian Patent Application #3600272/25vv086993, 6 June 1983 (in Russian), Russian PTO.
2. Bolonkin A.A., (1983b) Method of transformation of Plasma Energy in Electric Current and Installation for it. Russian Patent Application #3647344/136681, 27 July 1983 (in Russian), Russian PTO.
3. Bolonkin, A.A., *Non-Rocket Space Launch and Flight*, Elsevier, London, 2006, 488 pages,



- <http://www.scribd.com/doc/24056182>
4. Bolonkin, A.A., “*New Concepts, Ideas, Innovations in Aerospace, Technology and Human Science*”, NOVA, 2007, 502 pgs. <http://www.scribd.com/doc/24057071>
  5. Bolonkin A.A., and Cathcart R.B., *Macro-Projects in Environment and Technology*, NOVA, 2008, 536 pgs. <http://www.scribd.com/doc/24057930>
  6. Bolonkin A.A., *Human Immortality and Electronic Civilization*, Lulu, 2007, 3-rd Edition: English version 60 pgs, \$9.9; Russian version 101 pgs, \$9.9 . <http://www.scribd.com/doc/24053302>
  7. Encyclopedia of Physics. <http://www.physicum.narod.ru> (in Russian).
  8. Tables of Physical values. Reference book, Editor I.K. Kikoin, Moscow, 1976, 1006 pgs.(in Russian).
  9. AIP Physics Desk Reference, 3rd Edition, Springer, 2003. 888 pgs.
  10. Dresselhaus, M.S., *Carbon Nanotubes*, Springer, 2000.
  11. Wikipedia. Some background material in this article is gathered from Wikipedia under the Creative Commons license. <http://wikipedia.org>

Possible forms of future space apparatus used AB-matter



## Chapter 3

# Femtotechnology. AB-needles: Stability, Possible Production and Application

### Abstract

In article “Femtotechnology: Nuclear AB-Matter with Fantastic Properties” [1] *American Journal of Engineering and Applied Sciences*. 2 (2), 2009, p.501-514. (<http://www.scribd.com/doc/24045154>) author offered and consider possible super strong nuclear matter. But many readers asked about stability of the nuclear matter. It is well known, the conventional nuclear matter having more 92 protons or more 238 nucleons became instability. In given work the author shows the special artificial forms of nuclear AB-matter make its stability and give the fantastic properties. For example, by the offered AB-needle you can pierce any body without any damage, support motionless satellite, reach the other planet, researched Earth’s interior. These forms of nuclear matter are not in Nature now, but nanotubes also is not in Nature. That is artificial matter is made men. The AB-matter also is not now, but research and investigation their possibility, stability and properties are necessary for creating them.

**Key words:** Femtotechnology, FemtoTech, AB-matter, AB-needle, application AB-matter, stability AB-matter.

### 1. Introduction

**1. Brief history.** On December 29, 1959 the physicist Richard Feynman offered his idea to design artificial matter from atoms and molecules at an American Physical Society meeting at Caltech. If he was not widely well-known famous physicist, the audience laughed at him and drove away from the podium. All scientists accepted his proposal as joke. How can you see the molecule? How can you catch the molecule? How can you connect it to other? How many millions of years you will create one milligram of matter? And thousands of same questions don’t having answers may be asked. Any schoolboy has seed that Feynman proposal is full fantasy which does not relation to real technology.

About 40 years the scientists had not see a way for implementation of this idea. But only in the last 15 years we have initial progress in nanotechnology. On the other hand progress is becoming swifter as more and better tools become common and as the technical community grows.

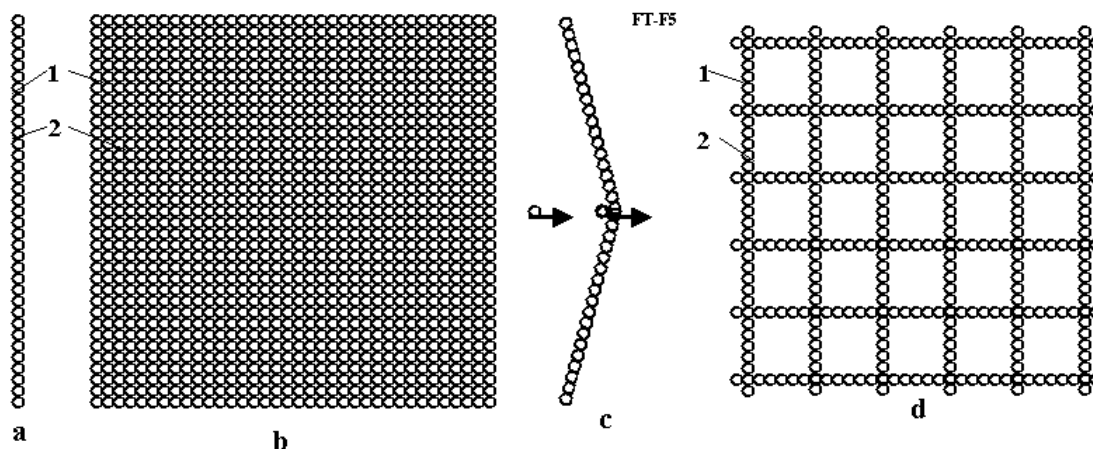
On 14 February 2009 the author offered the idea design of new matter from protons, neutrons and electrons, made initial research and published the article about it [1]. These particles in million times are smaller then molecules.

He researched and shown the new AB-matter will have the fantastic properties. That will be in millions times stronger than nanotubes and can keeps the millions degrees of temperature. That may be invisible and permeable to ordinary matter.

The many readers, who did not read carefully the author’s article and who remember from school course that the nucleus became unstable if number of protons are more 92 or number of nucleons is more 238, raised the cry that the AB-matter is impossible. They did not seen the main DIFFERENCE between conventional matter (conventional nucleus) and AB-matter. The conventional matter has nucleus which has a chaotic spherical LUMP (nucleus) of nucleons, the AB-matter is LINE from nucleons NOT having the nucleus.

The author considers below this AB-line and shows that line IS STABLE and has surprise property: one is a high rigid rod (needle), which the compressed force DOES NOT depend from rod length! This AB-rods (needles) you can support the Earth’s satellite, reach the other planets, penetrate into the Earth interior and into any molecules of man without damage of its body.

**2. Short information about offered matter.** In [1], figs.5, 6 it is shown the AB-matter may have forms (Fig.1).



**Fig.1.** Some form of AB-matter. (a) single string of the AB-matter (AB-needle); (b) continuous film from nuclear matter (nuclear grapheme); (c) cross-section of a matter film (side view). AB film under blow from proton or conventional molecular matter; (d) – net from the single strings (AB-needles). Notations: 1 – nucleons; 2 – electrons near AB-Matter.

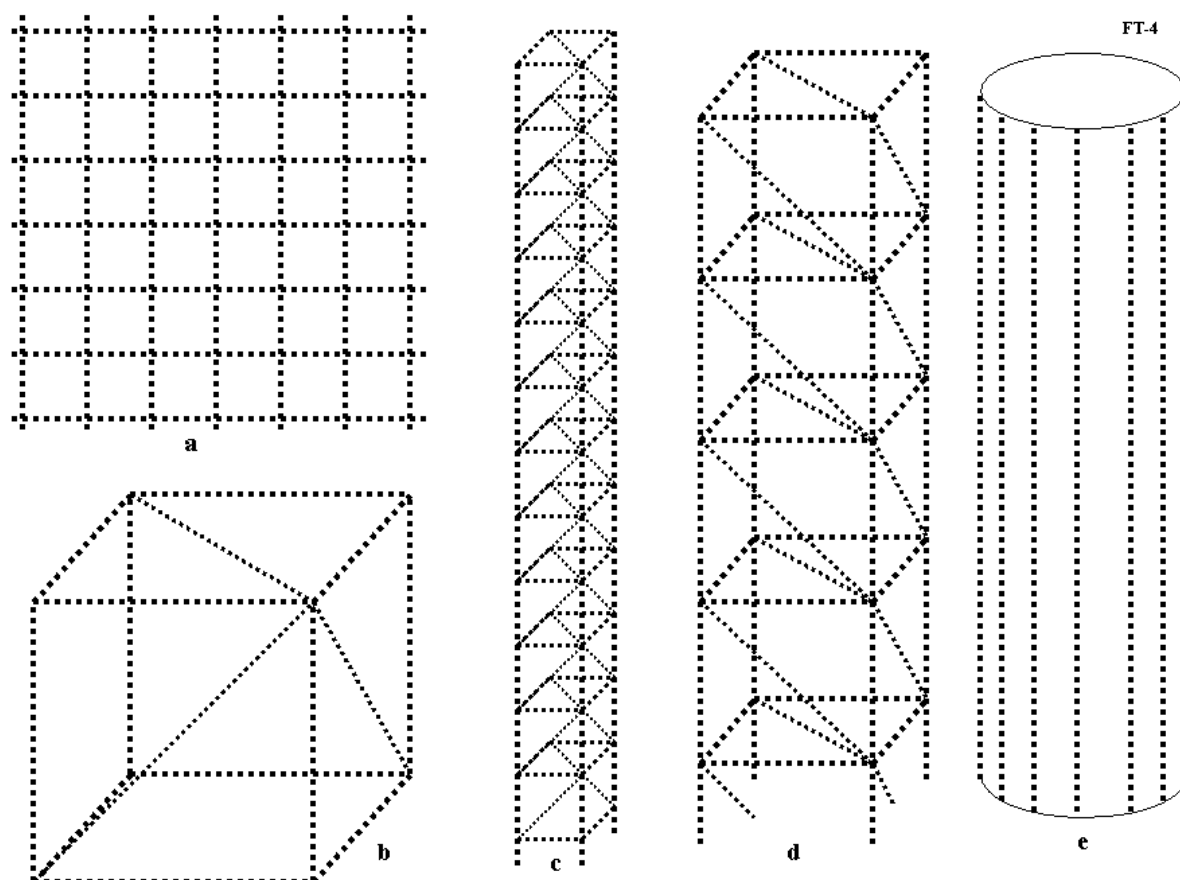
The main forms are: “a”- single AB-string (AB-needle), “b”- AB-film (plate), and “d” is net. From AB-needles may be design the many other forms (fig.2, taken from [1, fig.6]). That is net, cube, columns, tube and so on.

**3. AB-Matter.** In conventional matter made of atoms and molecules the nucleons (protons, neutrons) are located in the nucleus, but the electrons rotate in orbits around nucleus in distance in millions times more than diameter of nucleus. Therefore, in essence, what we think of as solid matter contains a -- relatively! -- ‘gigantic’ vacuum (free space) where the matter (nuclei) occupies but a very small part of the available space. Despite this unearthly emptiness, when you compress this (normal, non-degenerate) matter the electrons located in their orbits repel atom from atom and resist any great increase of the matter’s density. Thus it feels solid to the touch.

The form of matter containing and subsuming all the atom’s particles into the nucleus is named *degenerate matter*. Degenerate matter found in white dwarfs, neutron stars and black holes. Conventionally this matter in such large astronomical objects has a high temperature (as independent particles!) and a high gravity adding a forcing, confining pressure in a very massive celestial objects. In nature, degenerate matter exists stably (as a big lump) to our knowledge only in large astronomical masses (include their surface where gravitation pressure is zero) and into big nuclei of conventional matter.

Our purpose is to design artificial small masses of synthetic degenerate matter in form of an extremely thin strong thread (fiber, filament, string, needle), round bar (rod), tube, net (dense or non dense weave and mesh size) which can exist at Earth-normal temperatures and pressures. Note that such stabilized special form matter in small amounts does not exist in Nature as far as we know. Therefore author has named this matter **AB-Matter**. Just as people now design by the thousands variants of artificial materials (for example, plastics) from usual matter, we soon (historically speaking) shall create many artificial, designer materials by nanotechnology (for example, nanotubes: SWNTs (amchair, zigzag, ahiral), MWNTs (fullorite, torus, nanobut), nanoribbon (plate), grapheme, buckyballs (ball), fullerene). Sooner or later we may anticipate development of femtotechnology and create such AB-Matter. Some possible forms of AB-Matter are shown in fig.3.





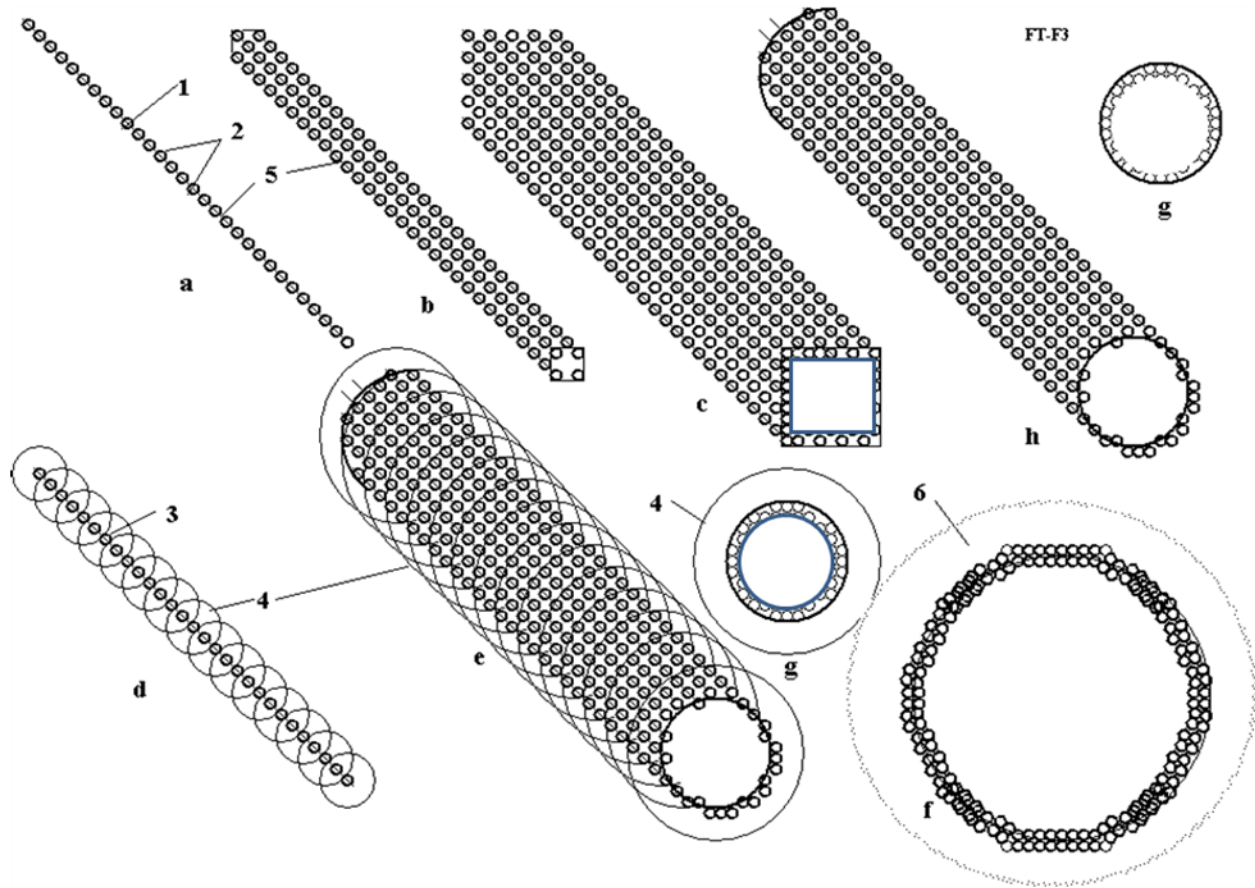
**Fig.2.** Structures from nuclear AB-strings (AB-needles). (a) nuclear net (netting, gauze); (b) primary cube from matter strings; (c) primary column from nuclear strings; (d) large column where elements made from primary columns; (e) tubes from matter strings (AB-needles) or matter columns.

The main difference the AB-matter from conventional matter is a strict order of location the proton and neutrons (for example: proton-neutron-proton-neutron-.... ) in line (string) or in the super thin (in one nucleon) plate (nuclear graphene). That gives the strong tensile stress (electrostatic repulse force) which does not allow the nucleons to mix in messy clump (ball). This force is less than a nuclear force if the AB-matter has a form where the most protons are located far from one other, where the nuclear force from the far protons is absent. That is in line, net and plate (fig. 1a,b,d), but that may be absent in the solid beam, rod (fig. 3c,d) if their cross-section area contains a lot of nucleons.

The other problem: compensation the positive charges is solved by rotation electrons around the AB string, rod, tube, net (grid) or an electron cloud near the plate [1] or the electron locates near nucleons,

**4. Using the AB-Matter.** The simplest use of AB-Matter is strengthening and reinforcing conventional material by AB-Matter fiber. As it is shown in the ‘Computation’ section [1], AB-Matter fiber is stronger (has a gigantic ultimate tensile stress) than conventional material by a factor of millions of times, can endure millions degrees of temperature, don’t accept any attacking chemical reactions. We can insert (for example, by casting around the reinforcement) AB-Matter fiber (or net) into steel, aluminum, plastic and the resultant matrix of conventional material increases in strength by thousands of times—if precautions are taken that the reinforcement stays put! Because of the extreme strength disparity design tricks must be used to assure that the fibers stay ‘rooted’. The matrix form of conventional artificial fiber reinforcement is used widely in current technology. This increases the tensile stress resistance of the reinforced matrix matter by typically 2 – 4 times. Engineers dream about a nanotube reinforcement of conventional matrix materials which might increase the tensile stress by

10 – 20 times, but nanotubes are very expensive and researchers cannot decrease its cost to acceptable values yet despite years of effort.



**Fig.3.**(it is taken from [1]). Design of AB-Matter from nucleons (neutrons, protons, etc.) and electrons. (a) linear one string (monofilament) (fiber, whisker, filament, thread, needle); (b) ingot from four nuclear monofilaments; (c) multi-ingot from nuclear monofilament; (d) string made from protons and neutrons with electrons rotated around monofilament; (e) single wall femto tube (SWFT) fiber with rotated electrons; (f) cross-section of multi wall femto tube (MWFT) string; (g) cross-section of tube; (h) - single wall femto tube (SWFT) string with electrons inserted into AB-Matter. *Notations:* 1 – nuclear string; 2 - nucleons (neutrons, protons, etc.). 3 – protons; 4 – orbit of electrons; 5 – nucleons; 6 – cloud of electrons around tube.

Another way is using a construct of AB-Matter as a continuous film or net (fig. 2b,d) or as the AB-needles (fig.2).

These forms of AB-Matter have such miraculous properties as invisibility, superconductivity, zero friction, etc. The ultimate in camouflage, installations of a veritable Invisible World can be built from certain forms of AB-Matter with the possibility of being also interpenetrable, literally allowing ghost-like passage through an apparently solid wall. Or the AB-Matter net (of different construction) can be designed as an impenetrable wall that even hugely destructive weapons cannot penetrate.

The AB-Matter film and net may be used for energy storage which can store up huge energy intensities and used also as rocket engines with gigantic impulse or weapon or absolute armor (see computation and application sections in [1]). Note that in the case of absolute armor, safeguards must be in place against buffering sudden accelerations; g-force shocks can kill even though nothing penetrates the armor!

The AB-Matter net (which can be designed to be gas-impermeable) may be used for inflatable construction of such strength and lightness as to be able to suspend the weight of a city over a vast span the width of a sea. AB-Matter may also be used for cubic or tower solid construction as it is shown in fig.3. Detail computation of properties the AB matter are in [1]. Our purpose is to show that the curtain forms of AB-matter will be stable.

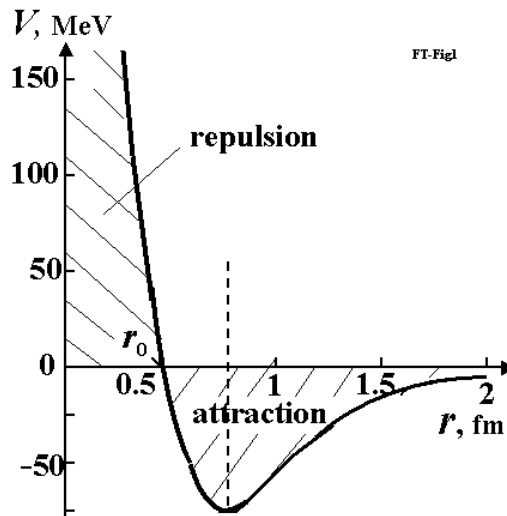
## 2. Law of Stability of the nuclear AB-matter

### 1. Short information about atom and nuclei.

Conventional matter consists of atoms and molecules. Molecules are collection of atoms. The atom contains a nucleus with proton(s) and usually neutrons (except for Hydrogen-1) and electrons revolve around this nucleus. Every particle may be characterized by parameters as mass, charge, spin, electric dipole, magnetic moment, etc. There are four forces active between particles: strong interaction, weak interaction, electromagnetic charge (Coulomb) force and gravitational force. The nuclear force dominates at distances up to 2 fm (femto,  $1 \text{ fm} = 10^{-15} \text{ m}$ ). They are hundreds of times more powerful than the charge (Coulomb) force and million-millions of times more than gravitational force. Charge (Coulomb) force is effective at distances over 2 fm. Gravitational force is significant near and into big masses (astronomical objects such as planets, stars, white dwarfs, neutron stars and black holes). Strong force is so overwhelmingly powerful that it forces together the positively charged protons, which would repel one from the other and fly apart without it. The strong force is key to the relationship between protons, neutrons and electrons. They can keep electrons into or near nuclei. Scientists conventionally take into attention only of the strong force when they consider the nuclear and near nuclear size range, for the other forces on that scale are negligible by comparison for most purposes.

Strong nuclear forces are anisotropic (non spherical, force distribution not the same in all directions equally), which means that they depend on the relative orientation of the nucleus. The proton has a magnetic moment which produces the magnetic force. This force orients the proton in magnetic field and help to keep the some form of AB-matter.

Typical nuclear energy (force) is presented in fig.4. The nuclear and electric forces can be attractive and repulsive. When it is positive the nuclear force repels the other atomic particles (protons, neutrons). When nuclear energy is negative, it attracts them up to a distance of about 2 fm. The value  $r_0$  usually is taken as radius of nucleus.



**Fig.4.** Typical nuclear force of nucleus. When nucleon is at distance of less than 1.8 fm, it is attracted to nucleus. When nucleon is very close, it is repulsed from nucleus.  
(Reference from <http://www.physicum.narod.ru> , Vol. 5 p. 670).

## 2. Law (necessary conditions) of stability the AB-matter.

The necessary condition (prerequisite **LAW**) of stability the AB-matter are following:

- 1) *The number of protons must be less approximately 90 into a local sphere of radius 3 fm in any points of AB-matter;*
- 2) *The number of nucleons must be less approximately 240 into a local sphere of radius 3 fm in any points of AB-matter.*
- 3) *The AB-matter contains minimum two protons.*

That law follows from relation between attractive nuclear and repulsive electrostatic forces into nucleus. The nuclear force is short distance force (2 fm), the electrostatic force is long distance. When number of protons is more 92, the repulsive electrostatic force may became the more than nuclear force and electrostatic force may destroy the AB-matter.

**Consequent.** That law means: the number of nucleons in any cross-section area AB-matter design of fig.3 must be less 37.

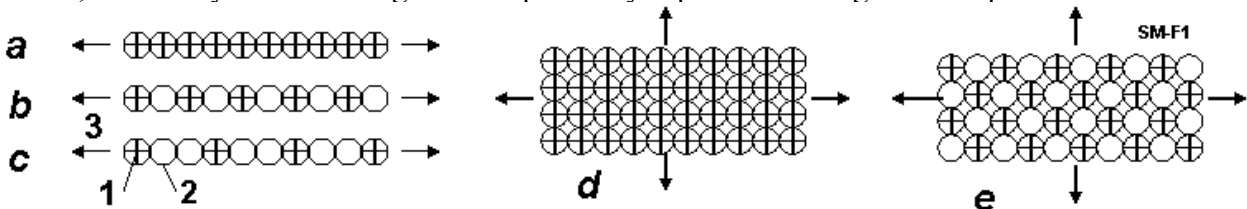
It is not limited the press strong possibilities of the AB-matters because AB-needles has the surprising property discovered by author – keep the huge press force in any length of AB-needle (transfer the pressure to any long distance). That property is described in next paragraph.

## 3. AB-needles

The most important design of AB-matter is connection of nucleons in string (fig.5a,b,c). That may be only protons *pppp....* (fig.5a), proton-neutron-proton-neutron-.... (*pnpn....*)(fig.5b), proton-neutron-neutron-proton-neutron-neutron-.... (*pnnpnn....*)(fig.5c). The ends of AB-string contains the protons. The electrostatic repulse force of these end protons is not BALANCED and create the strong repulsive force 3 (fig.5c,d,e) which stretches the AB-string. That helps to keep the string form and other form (plate, tube, beam, shaft, rod, etc.) of AB-matter presented in figs. 3, 5.

Than is very important properties. This property does not have the conventional molecular matter, because the conventional matter contains the neutral molecules. The charges of ions in conventional matter locate far one from other and repulsive force is small. That property discovered by author gives the AB-string the amusing feature: an independent of the safety press stress from LENGTH of the nuclear string. Remand: the safety press force of long conventional matter strong depends from length of wire, beam, shaft, etc. According to the Euler's law the safety compressive force in the ordinary matter is inversely proportional to the square of the length of the rod. If the length of rod is more the safety length, the construction loss the stability (one is bending). You cannot push the car a thread or thin wire having one km length. They bend.

The AB thin string can pass the compressive force for any length of string. That why it is named the **AB-needle**. AB-needle allows penetrating into any conventional matter, into the interior of Earth, planets, Sun. They allow making the interplanetary trips and investigations of planet from Earth.



**Fig.**

5. Connection of nucleons in string (needle) (fig.2a,b,c) and film, plate (fig.5d,e) and Coulomb

(electrostatic, repulse) force. Notations: 1- protons, 2 – neutrons, 3 - repulse (Coulomb) force from protons.

### Computation (Estimation) of forces in AB-needles.

Let us estimate the forces into AB-needle.

1) **Nuclear attractive force.** The radius of proton is  $r = 0.877$  fm ( $10^{-15}$  m). The connection energy of proton and neutron  $pn$  ( $^2\text{H}$  or  $^2\text{D}$ ) is about  $E = 1$  MeV =  $1.6 \times 10^{-13}$  J; the connection energy of  $pnn$  ( $^3\text{H}$  or  $^3\text{He}$ ) is 3 MeV; the energy of  $pnpn$  ( $^4\text{He}$ ) is 4 MeV. Let us take the average connection energy 2 MeV. The distance (where the nuclear force is active) is about  $l = 1$  fm. Consequently the average attractive nuclear force is

$$F = \frac{E}{l} = \frac{2 \times 1.6 \times 10^{-13}}{10^{-15}} = 320 \text{ N} \quad (1)$$

The maximum attractive nuclear force is approximately in two times more, about 600 N.

That is huge value because the cross-section area of AB-needle is millions times less than the diameter of the simplest molecules of hydrogen. Note: this force appears only when the outer force went to break the AB-needle. If no outer tensile force the internal strong nuclear force equals zero.

2) **The repulse electric force between protons.** Let us consider the AB-needle contains only protons  $pppp\dots$  (Fig.5, mark 1). The repulse force between two protons equals

$$F_{1p} = k \frac{e^2}{(2r)^2}, \quad (2)$$

where  $k = 9 \cdot 10^9$ . Substitute an electric charge  $e = 1.6 \cdot 10^{-19}$  C and  $2r = d = 1.754$  fm. We receive  $F_{1p} = 74.8$  N.

The electric repulsive force decreases with distance  $d = 2r$  between protons. If we summarize the repulsive force from all protons in line  $pppp\dots$  of AB-needle (fig.5, marked 1), we received

$$F_p = 1.64 F_{1p} \approx 123 \text{ N}. \quad (3)$$

That means the AB-needle has gigantic internal stress which extend the AB-needle. That extended stress is less than the attractive maximum nuclear force and one does NOT depend from length of AB-needle. This extended stress decreases the maximal outer stretch force but one allows to keep the AB-needle the compress force while they are less than extended force. If the press force is more than extended force the AB-needle not break, that only bends and continue to keep the maximal press force.

In case the AB-needle has form  $pnpn\dots$  (fig.5 marked 2) the distance between protons decreases in two times. That means the force  $F_p$  (3) decreases in four times ( $2^2 = 4$ ) and equals  $F_p \approx 30$  N.

In case  $pnnpnn\dots$  (fig. 5, mark 3) the force  $F_p$  (3) decreases in nine times ( $3^2 = 9$ ) and equals  $F_p \approx 14$  N.

This tensile stress is transmitted through the protons to other end of AB-needle. That means the large pressure on the ends of AB-needle is passing along thin AB-needle through electrostatic repel force and one does not depend from length of AB-needle.

That may be illustrated by a children long inflatable air-balloon (fig.7a). This press force also not depends from length of balloon. The force is transferred by compressed air. This idea was used by author in design the inflatable space tower [Bolonkin A.A., Non-Rocket Space Launch and Flight, Elsevier, 2005, Ch. 4].

The tension  $F_p$  active along all length of AB-needle and does not allow to curl the AB-string into the lamb – conventional nucleus. This tension works when no other closed protons with a side of the string. When AB-needle is created, the outside protons cannot joint to AB-needle because the protons repel each other.

The proton and neutron have the magnetic dipole moments. Magnetic dipole moment of proton equals  $+1.41 \cdot 10^{-26}$  J/T, of neutron equals  $-0.966 \cdot 10^{-26}$  J/T. They are small magnets having magnetic force some newtons. That also allows creating the stable AB-needles, to arrange them in a certain position and order.

The AB-needle can also keep the maximal side force  $F2 \approx 0.5F1$  (fig.7b). That allows to accelerate

anybody (for example space ship) in side direction, to produce an elastic design (for example, air bridge, storage of mechanical energy, long arm (hand), etc.). AB-matter designs do not have the drawbacks of the ordinary matter as fatigue, residual strain and the susceptibility to the external environment.

One meter of AB-needle has line having  $n = 5.7 \cdot 10^{-14}$  nucleons with mass  $m = 1.67 \cdot 10^{-27}$  kg. Total mass of one meter AB-needle equals only  $10^{-12}$  kg/m.

$$M_1 = nm = 5.7 \cdot 10^{-14} \times 1.67 \cdot 10^{-27} = 10^{-12} \text{ kg/m.}$$

One millions of kilometers of AB-needle weights only  $10^{-3}$  kg/Mm. For transfer the large force we can take the thin cable from AB-needles.

**Summary:** Three above necessary condition, repulsive force of protons and magnetic force of nucleons can make the stability AB-matter.

#### 4. Application of AB-needles.

Some properties of AB-matter are considered in [1] and here. That has a gigantic strength. The maximal tensile stress equals  $\sigma_t \approx 8 \cdot 10^{31}$  N/m<sup>2</sup> (nanotubes has only  $\sigma_t \approx 2 \cdot 10^{11}$  N/m<sup>2</sup>, that is in 100 billion billion times less), high maximal pressure stress of the long stability AB-needle equals about  $\sigma_t \approx 7.5 \cdot 10^{30}$  N/m<sup>2</sup>, the safety temperature is millions of degrees.

The many applications of super strong AB-matter are shown in [1]-[6]. The discovery by author the unique property of super thin AB-needle to transfer the pressure in any long distance opens the new gigantic application of AB-needles. Some of these applications are shown below.

In our consideration you must remember that nuclear AB-needle in million times is less than the simplest hydrogen molecule. Our AB-needles in this molecule is as conventional rod traveling in Solar system. The probability to meet planet, asteroid or meteor in space is very small. The tens of thousands the artificial wastes are rotate around (near) Earth. The meet with any of them is catastrophe for satellite or space ship or station. But no case when a space garbage damaged the space ship. Into molecular space the AB-needle can meet very rare only nucleus. But they charged positive as AB-needle and they will move away by electric force from AB-needle.

**1. Penetration into human body.** We can penetrate into the human body by AB-needle (cable from AB-needles) without body damage. We reach in any cells of human body. We can design the artificial arm (hand) (fig.7f) of the long in hundreds of kilometers, connect to end of arm the femto TV, femto devices, observe and manipulate into human body.

We can work from distance in hundreds kilometers. The man will not see our artificial arm and not feel as AB-needle penetrates into his body. We can repair or damage his body. Any conventional wall, armor, underground shelter cannot to protect him, except special AB-matter (AB-armor).

We can build (work) by AB-hand the home when we locate hundreds or thousands of kilometers from objects.

**2. Geological exploration.** Capability of AB-needle to penetrate into any conventional matter is very useful in geology. The AB-needle having the need femto devices can reach the any depth of the Earth (include kernel) and investigate and research them (fig.6f). Search for minerals is greatly simplified. You can find oil, gas, water, gold under your house. Moreover as it will be shown later you can search of minerals into other planets, asteroids without space flight, sitting at home. You can research the internal kernel of Sun because the AB-needle can keep the millions of degree temperature.

**3. Transportation of any body.** You can take by artificial AB-hand any things in distance hundreds kilometers and move to you or any other place.

**4. Air transportation.** You can connect any cities by air line of AB-needles (fig.7f) and delivery loads. This line is not an obstacle for general aviation and matter. They will not see and not feel it. The

cars, tracks, individual men can move along them using the special hook and motor. For people on ground they are flying in the sky. The invisible air bridge through the strait, river, gulf, canyon, mountain may be built in some minutes.

**5. Suspending houses.** The building may be suspended over Earth (include sea, ocean) surface. The invisible, permeable AB-rod will support them (fig. 7e). They do not damage environment and cheaper of conventional building because they do not having the house foundation. People have a beautiful view. The humanity can colonize the sea and ocean.

**6. Storage of mechanical energy.** The AB-cable wounded on a microscopic coil is capable of accumulating the gigantic energy and return it as mechanical energy with 100% efficiency. That may be rotation (as spring in old mechanical clock) or a push force as it shown in fig.7b.

Estimation of a maximal specific storage energy  $E_{ms}$  [N/kg] approximately is

$$E_{ms} = \frac{F_p L}{2M}, \quad (3)$$

where  $L$  is length of AB-cable, m;  $M$  is mass of AB-cable, kg;  $F_p$  is maximal safety repulse force of cable, N. For cable *pnpn...* this energy may rich about  $10^{13}$  J/kg. Cable may contain thousands of AB-needed. That is in million time more than energy in explosive TNT. The density of energy may be also very high value up  $10^{21}$  J/m<sup>3</sup>. That is thousand billions of time more than energy density of a rocket fuel.

**7. Protection by AB-matter.** The AB-net (figs. 1d, 2a) may be used as filter for the radiation and molecules (matter). It is known, if the length of radiation wave is less than filter cell, the given type of radiation cannot penetrate through this grid. If diameter of molecule is more than filter cell, the molecule cannot penetrate through the given net. The AB-net (grid) may be used for the separation of different matters (gas or liquid), for example: for cheap getting the fresh water from sea water; for separation the carbon dioxide from atmosphere, chimneys, car exhaust tubes, oxygen from atmosphere, radioactive dust from atmosphere and water, etc. The AB-net may be used for protection from dangerous nuclear radiation, poisonous gases, and so on. We can create the invisible light wall which will protect us from terrorists.

Below is table which shows the some properties of some protection of AB-nets.

Table 1. Protection of some AB-nets (pnpn...) and their properties.

No	Type of radiation or molecules	Size of AB-net sell, m	Mass of AB-net kg/m <sup>2</sup>	Max. press stress, N/m	Max. tensile stress, N/m
1	Visible light	$10^{-7}$	$2 \cdot 10^{-5}$	$3 \cdot 10^8$	$3.35 \cdot 10^9$
2	Hard X-ray radiation	$10^{-12}$	2	$3 \cdot 10^{13}$	$3.35 \cdot 10^{14}$
3	Gamma (nuclear) radiation	$10^{-13}$	20	$3 \cdot 10^{14}$	$3.35 \cdot 10^{15}$
4	Protection from AB-needed	$2 \cdot 10^{-15}$	420	$1.5 \cdot 10^{16}$	$1.6 \cdot 10^{17}$
5	Protection from molecules	$2.7 \cdot 10^{-8}$	$7.4 \cdot 10^{-5}$	$1.11 \cdot 10^9$	$1.2 \cdot 10^{10}$

**8. AB-needed and space flight.** The AB-needed (cables) open the gigantic possibilities in the space research and flight.

You can use the AB-hand manipulator (arm) from AB-needed having length of hundreds millions kilometers and keeping the femto devices in end (fig.7d). If mass of devices is 1 – 10 kg, the mass of AB-hand must be 1 – 10 grams for 1 million of kilometers. The distance to Moon is 384,400 km, to Mars 78 millions km (when Mars is closest position, every two years). You can study and research these space bodies (include interior) from your home. Moreover, using the power AB-hand, you can



build house on the plane before you will travel to it.

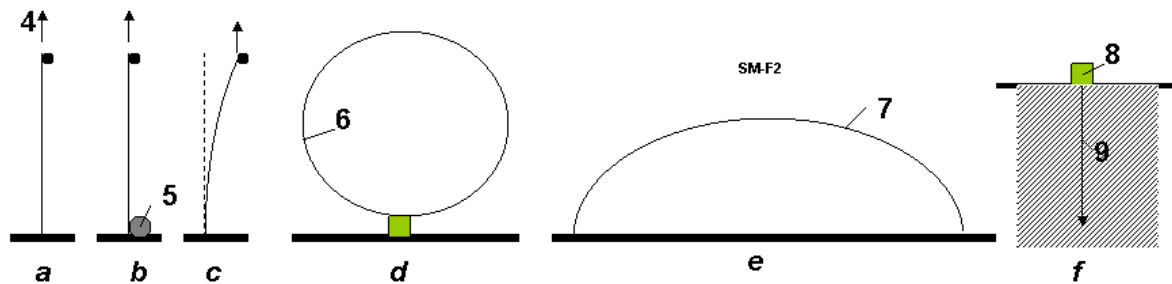
We can lift by AB-cable the loads into space in a distance in thousand km (figs. 6b, 7b), keep the motion less satellites, and delivery the satellites to other planets. No problem, to build the Space Elevator include GEO (and over) Space Elevator from Earth surface (fig.7c). No problem with conventional cable for Space Elevator. Any space garbage, meteorite from conventional matter cannot damage the femto cable because the femto cable penetrates the nano matter.

We can free and quick flight to space in the manner space ships (fig.7d). The small spool of AB-cable will accelerate and inhibit the space ships and permanent connection of him to Earth. Below reader finds computation the time, speed and some other parameters of space flights to planets of solar system by offered AB-space ship.

Table2. Computation of space flight to solar planets by manner AB-space ship.  
The acceleration and inhibition have  $g = 10\text{m/s}^2$ , mass of space ship is 3 tons.

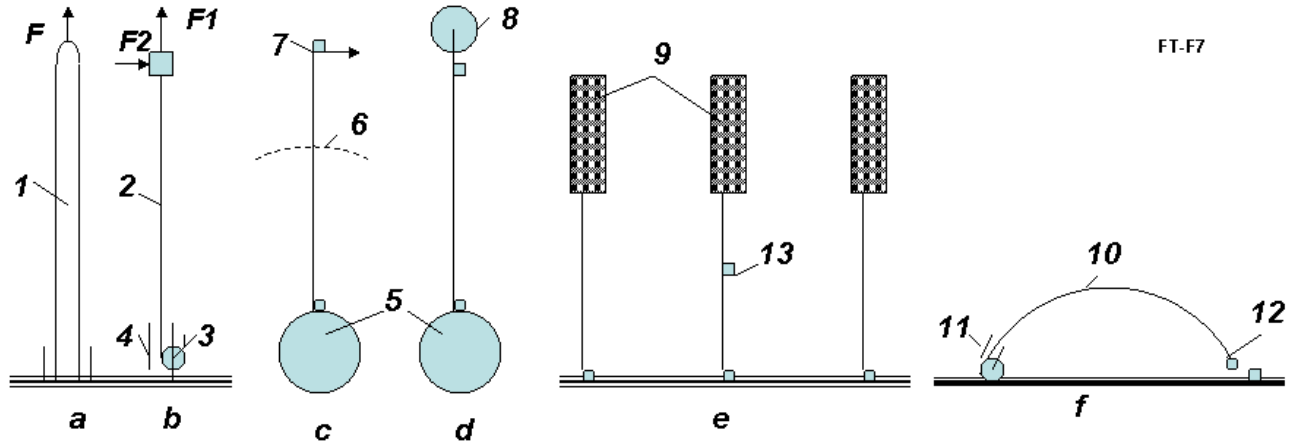
No	Planet	Distance from Sun $10^{10}$ km	Distance from Earth $10^{10}$ km	Flight* time, $10^3$ sec	Flight time, Days	Max. speed, km/s	Mass of AB-cable kg
1	Mercury	5.79	9.2	19.2	2.22	1382	184
2	Venus	10.8	4.2	13	1.5	1140	84
3	Earth	15	0	-	-	-	-
4	Mars	22.8	7.8	17.7	2.04	883	154
5	Jupiter	77.8	62.8	50.1	5.8	2239	1356
6	Suturn	142.7	127.7	71.5	8.28	2674	2550
7	Uranus	286.9	281.9	107	12.4	3271	5638
8	Neptune	449.7	434.7	132	15.3	3633	8694
9	Moon	-	0.0384	1.24	0.14	352	0.77
10	Sun	-	15	25.5	3	1597	300

\*include inhibition with  $g = 10\text{ m/s}^2$ .



**Fig.6.** Some construction from AB-string. *Notations:* *a* – vertical string (AB-needle). The big lift (support) force 4 does not depend from length; *b* – lifting the load to any altitude. 5 - spool of AB-string; *c* – stability of AB-string; *d* – ring 6 from AB-string; *e* – bridge (long arm) from AB-string; *f* – research of the Earth crust interior: 8 - installation (spool of AB-needle), 9 – AB-needle (string,cable).





**Fig. 7.** Applications of AB-needles. Notations: *a* – conventional children inflatable long tube illustrated the capability to accept the pressure in end of tube ( $F$  – force); *b* – illustration of AB-needle to lift the load, accepts the vertical and horizontal forces ( $F_1, F_2 = 0.5F_1$ ); *c* – AB-needles as the over GSO Space Elevator; *d* – AB-needles as space ship and the investigator of the planet interior (for example Moon); *e* – the building suspended at high altitude by AB – needles, *f* – the investigation of interior of building, men, etc. by AB-needles. 1- conventional children inflatable long tube (air balloon); 2 – AB-needles; 3 – reel of AB-needles; 4 – the guides of AB-needles; 5 – Earth; 6 – Geosynchronous orbit; 7 – space ship; 9 - building; 10 – AB-needle; 11 - the guides of AB-needles; 12 – devices (TV-camera, capture grid, weapon, etc.); 13 – elevator.

In any case the safety press force is very high because we can take the thousands AB-needles and push any load (space ship, anybody) or keep them at any altitude.

## 5. Production of AB-needles

The charged particles interact with electric and magnetic fields. The magnetic moment interacts with magnetic field. That allows designing the technologies for production of artificial AB-matter. Some offered technologies were described in [1]. Here the author offers some new technologies.

The possible particles is shown in Table 3.

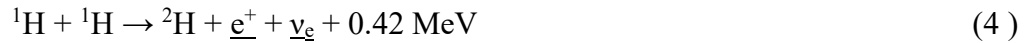
Table 3. Charge, impulse and magnetic moments of some nucleus

Z	Nucleus (particles)	Charge $+e=1.6 \cdot 10^{-19}$ C	Mass number	Impulse moment, $\hbar$	Magnetic* moment, $\mu_N$
0	n	0	1	1/2	-1.9125
1	p	1	1	1/2	2.7828
1	$^2\text{H} = \text{D}$	1	2	1	0.8565
2	$^3\text{He}$	2	3	1/2	-2.121
2	$^4\text{He}$	2	4	0	0
3	$^6\text{Li}$	3	6	1	0.821
3	$^7\text{Li}$	3	7	3/2	3.2332

\*Nuclear magnetron  $\mu_N = 5.051 \cdot 10^{-27}$  J/T. Sign “-“ shows: magnetic moment is opposite the impulse moment.

**Notes about possible form AB-needles.** The possible form of AB-needles are shown in fig. 8.

The **first form** marked 1 (pppp...) contains only line of protons. This form is cheapest and has maximum the pressure strength. But it is unknown, this form is possible or no. It is known the single hydrogen and single proton is stable. In other side the fusion of two SINGLE hydrogen nuclei  $^1\text{H}$  (protons) produces deuterium  $^2\text{H} = \text{D}$  ( $pn$ ) releasing a positron and a neutrino as one proton changes into a neutron:



The fusion reaction released in this step produces energy up to 0.42 MeV. The most of this energy is taken away by neutrino.

The positron immediately annihilates with an electron, and their mass energy is carried off by two gamma ray photos:



But the most nucleus has a lot of protons and they not relies the reaction (4). The AB-needle also has a lot of protons. If reaction (4) is released, the form 1 transfers in form 2 (fig. 8) and the process produces a lot of a nuclear energy. The ionized conventional hydrogen  $^1\text{H}$  may be used for production of AB-matter. I remain: the Universe is composed of about 80% hydrogen. In result we will have the AB-needle in form  $npnp\dots$  .

The **second form** of AB-needle is  $pnpn\dots$  marked 2 (fig.8). This form may be produced directly from deuterium  $D$  oriented by magnetic field along axis of AB-needles.

The **third form** of the double AB-needles marked 3 (fig. 8) also may be produced directly from deuterium  $D$  oriented by magnetic field perpendicular of axis of AB-needles.

The **forth form** of four-needles marked 4 (fig.8) may be produced directly from helium  $^4\text{He}$  oriented by magnetic field perpendicular of axis of AB-needles.

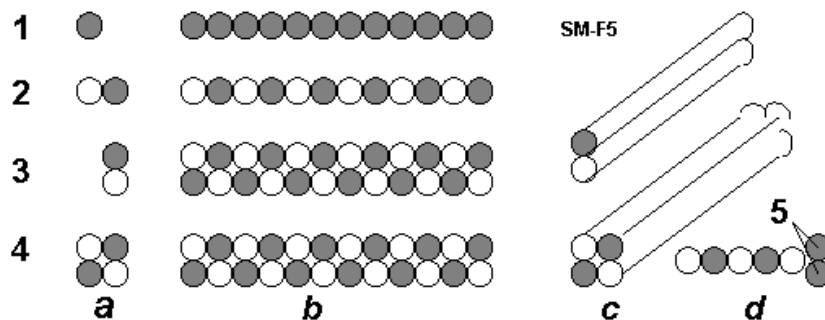


Fig. 8. Types of AB-needles. *Notations:* **a** – Nucleus: black is  $p$ , white is  $n$ ; **b** – AB-needles (side view); **c** – AB-needles in isometrical view; **d** – increasing the internal tensile stress by the double protons (5) located in the end of single AB-needle from protons (for increasing the tensile stress); 1- protons ( $p$ ). Single AB-needles from proton; 2 – deuterium  $^2\text{H} = \text{D}$  ( $pn$ ). Single AB-needles from deuterium; 3 - deuterium  $^2\text{H}$  ( $pn$ ). Double AB-needles from deuterium; 4 – helium  $^4\text{He}$ . 4 – square AB-needles from helium. 5 – double protons in end of single AB-needle.

#### Installations for production AB-needles.

1) **Toroid method.** One of installation for production of AB-needles is shown in fig. 9. The installation has a vacuum topoid 1 and particles gun 4 which injects charged particles into toroid. The perpendicular (to fig.) magnetic lines 2 penetrate the toroid. As result the charged particles 3 move in circles inside the toroid. This electric current of particles produces the magnetic field 5 (pinch-affect). This field pulls the particles in a cord and helps to keep them into the toroid ring.

The producing AB-needles 8 locate inside the toroid ring and are kept by special local magnetic field 9 in position along the circle axis of the toroid ring. That means the moving particles can connect to AB-needles only to end nucleus when they collide the forward end of AB-needle and their energy is sufficient to overcome the Coulomb repulsion. The toroid ring has the accelerators 6, 11 and focusers 7, 10 of particles. Their electric fields collect the scattered charged particles back to toroid axis.

Probability of hitting in the front end of the AB-needles is small. But the charged particles rotate into toroid a lot (millions) of times and join to end of AB-needles. Note they can connect only to end of AB-needle. Their perpendicular speed to the toroid circle axis does not enough for overcame the nuclear repulsion force.

Author wrote only the principal scheme (schematic diagram) of the AB-needle producing. The developing of this method may request a big research and work.

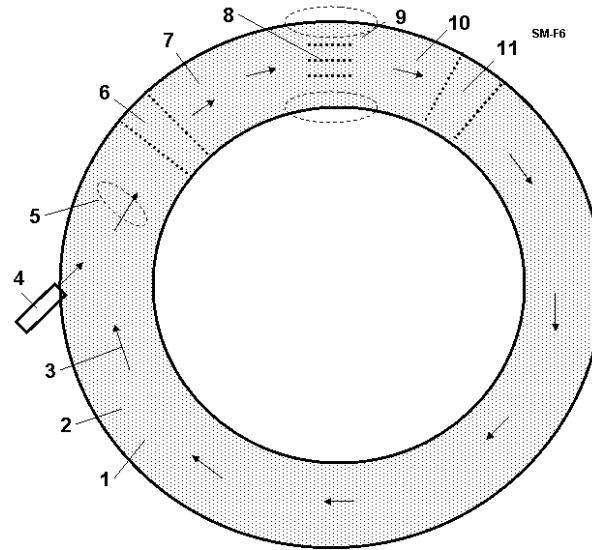


Fig.9. Toroid Producer of AB-needles (AB-matter). *Notations:* 1 – vacuum toroid; 2 – perpendicular (to sketch) magnetic lines; 3 – particles; 4 - particles gun; 5 – round magnetic lines from motion charged particles; 6 – electric accelerator; 7 – electric focuser; 8 – AB – needles; 9 – magnetic field keeping the AB-needles; 10 – electric focuser; 11 – electric accelerator.

2) The Second method: **Method particles traps**. That is shown in fig. 10. That is closed to method described in [1]. Feature is the net of traps 8 (fig.10a and 10b). They catch the particles and direct them to end of creating AB-needles. Advantage is high efficiency of production AB-matter (every charged particle will be used, small of energy consumption). Lack is the request of a special form of AB-matter (see 8 in fig. 10b). That method may be useful when we have enough AB-matter.

3) Third method: **Method standing waves**. The current special mirrors [4, Ch.12] and lasers allow to create the net of electromagnetic traps for AB-matter producer (fig. 11) from the monochromatic polarized electromagnetic standing waves (fig. 11a,b). That net may partially changes the net of AB-matter traps of the fig. 10b and increase the efficiency. This method may be useful for AB-matter producer in [1].

The threads from AB-Matter are stronger by millions of times than normal materials. They can be inserted as reinforcements, into conventional materials, which serve as a matrix, and are thus strengthened by thousands of times (see computation section in [1]).

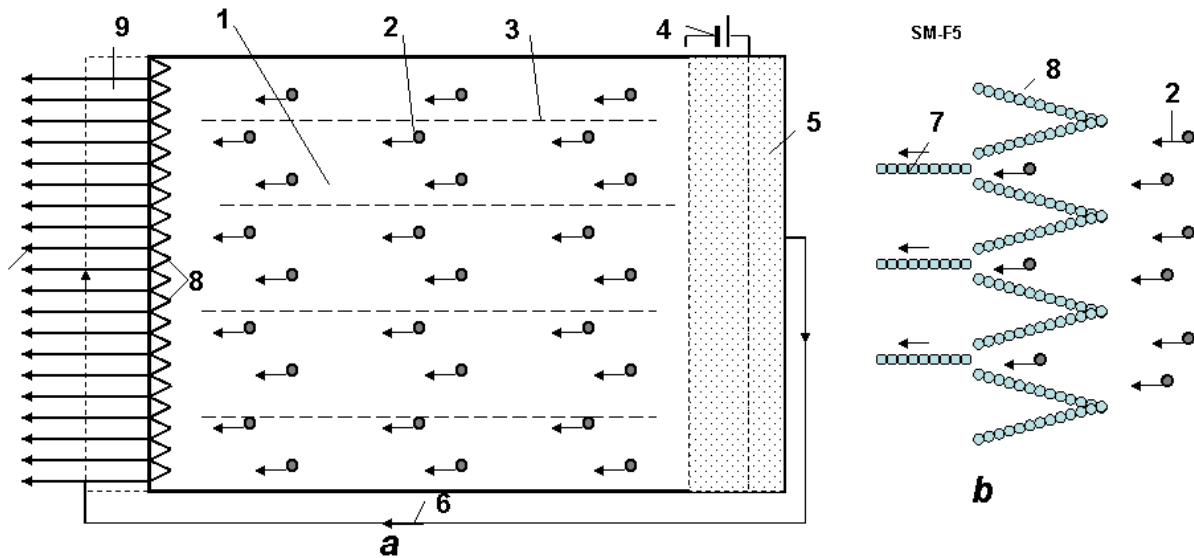


Fig. 10. Method particle traps for production of the AB-needles. Notations: **a** – device; **b** – particle traps; 1 - vacuum cell; 2- charged particles; 3 – magnetic lines; 4 – electric issue for the acceleration nets; 5 - plasma from particles; 6 – flow of electrons; 7 – AB-needles; 8 – trap made from AB-matter for the charged particles ( $p$ ,  ${}^2\text{H}$ ,  ${}^4\text{He}$ , etc.); 9 – cell for cover the AB-needles by electrons.

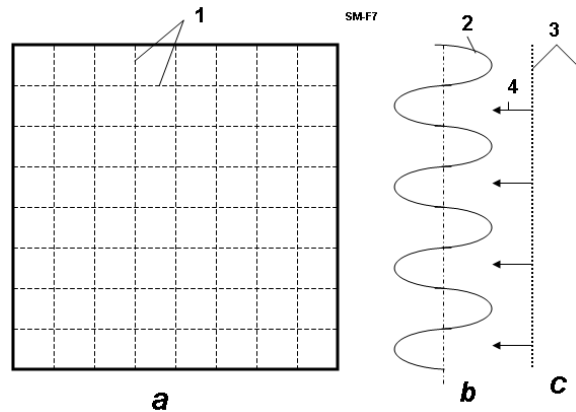


Fig.11. Net of electromagnetic traps for AB-matter producer. Notations: (a) – forward view; (b) – the monochromatic polarized electromagnetic standing waves (electrostatic part, side view); (c) – particles storage and accelerator; 1 – net from the perpendicular monochromatic polarized electromagnetic standing waves; 2 - the electromagnetic monochromatic polarized standing wave; 3 – electric accelerator of particles; 4 – particles.

The offered AB-producers can be used for production the new NANO-matters. Now the scientist offers to produce nano-matters by nano-robots. I think that is very difficult way. The nano-robot must has the devices for searching, recognizing, catching the flying molecules, delivers them in given place, connection to other selected molecules. That means the nano-robot must have a millions molecules. Difficult to get an elephant to catch the flies and glue them from the device. This productivity will be very low. The production of AB-matter may be easy.

Also we can ionize the molecules (create the charged particles!) and apply the modified offered methods for design and production of the nano-matters.

## Discussion

The Humanity will make a gigantic jump in technology when one will produce AB-matter. We consider unconventional application of AB-matter.

1. **Super Micro-World from AB-Matter: An Amusing Thought-Experiment.** AB-Matter may have  $10^{15} \div 10^{43}$  times more particles in a given volume than a single atom. A human being, man made from conventional matter, contains about  $5 \times 10^{26}$  molecules. That means that 'femto-beings' of equal complexity from AB-Matter (having same number of components) could be located in the volume of one microbe having size  $10 \mu = 10^{-5}$  m. It is difficult to make the nano-robot (one is large for Nano World). But the smart small femto-robot is suitable for Nano World. In future the people could make the artificial intelligent super micro F-beings which can withstand a huge temperature, acceleration of electric field, travel to other stars, other galactic, live in stars and travel through black holes to other Universes and times.

### 2. Stability of AB-matter.

Readers usually ask: the connection (proton to proton) gives a new element when, after 92 protons, this element is unstable?

*Answer:* That depends entirely on the type of connection. If we conventionally join the carbon atom to another carbon atom a lot of times, we then get the conventional piece of a coal. If we join the carbon atom to another carbon atom by the indicated **special forms**, we then get the very strong single-wall nanotubes, graphene nano-ribbon (super-thin film), armchair, zigzag, chiral, fullerite, torus, nanobud and other forms of nano-materials. That outcome becomes possible because the atomic force (van der Waals force, named for the Dutch physicist Johannes Diderik van der Waals, 1837-1923, etc.) is NON-SPHERICAL and active in the short (one molecule) distance. The nucleon nuclear force also is NON-SPHERICAL and they may also be active about the one nucleon diameter distance (Fig. 1). Moreover the nucleus have a **tensile electrostatic force** which allows to design the long linear structures. Moreover the proton is a small magnet. As magnet that (and nucleus) connects one to other specific side. That means we may also produce with them the strings, tubes, films, nets and other geometrical constructions.

The further studies are shown that AB-matter will be stability if:

- 1) The any sphere having radius  $R \approx 6 \times 10^{-15}$  m in any point of structure figs. 1 – 4 must contain NOT more 238 nucleons (about 92 of them must be protons). That means any cross-section area of the solid rod, beam and so on of AB-structure (for example figs. 1b,c,g) must contain NOT more about 36 nucleons in any circle with  $R \approx 6 \times 10^{-15}$  m.
- 2) AB-matter must contains the proton in a certain order because the electrostatic repel forces of them give the stability of the given structure.
- 3) The magnetic force of protons allows also gives the different form of AB-matter.

## Conclusion

The author offers a design for a new form of nuclear matter from nucleons (neutrons, protons), electrons, and other nuclear particles. He also suggested the necessary conditions of stability of AB-matter. He shows that the new AB-Matter has most extraordinary properties (for example, (in varying circumstances) remarkable tensile strength, stiffness, hardness, critical temperature, superconductivity, super-transparency, ghostlike ability to pass through matter, zero friction, etc.), which are millions of times better than corresponded properties of conventional molecular matter. He shows (in [2]) how to design aircraft, ships, transportation, thermonuclear reactors, and constructions, and so on from this new nuclear matter. These vehicles will have correspondingly amazing possibilities (invisibility, passing through any walls and amour, protection from nuclear bombs and any radiation, etc).

People may think this fantasy. But fifteen years ago most people and many scientists thought – nanotechnology is fantasy. Now many groups and industrial labs, even startups, spend hundreds of millions of dollars for development of nanotechnological-range products (precise chemistry, patterned atoms, catalysts, metamaterials, etc) and we have nanotubes (a new material which does not exist in Nature!) and other achievements beginning to come out of the pipeline in prospect. Nanotubes are stronger than steel by a hundred times—surely an amazement to a 19<sup>th</sup> Century observer if he could behold them.

Nanotechnology, in near term prospect, operates with objects (molecules and atoms) having the size in nanometer ( $10^{-9}$  m). The author here outlines perhaps more distant operations with objects (nuclei) having size in the femtometer range, ( $10^{-15}$  m, millions of times less smaller than the nanometer scale). The name of this new technology is femtotechnology.

I want to explain the main thrust of this by analogy. Assume we live some thousands of years ago in a great river valley where there are no stones for building and only poor timber. In nature we notice that there are many types of clay (nuclei of atom—types of element). One man offers to people to make from clay bricks (AB-Matter) and build from these bricks a fantastic array of desirable structures too complex to make from naturally occurring mounds of mud. The bricks enable by increased precision and strength things impossible before. A new level of human civilization begins.

I call upon scientists and the technical community to research and develop femtotechnology. I think we can reach in this field progress more quickly than in the further prospects of nanotechnology, because we have fewer (only 3) initial components (proton, neutron, electron) and interaction between them is well-known (3 main forces: strong, weak, electrostatic). The different conventional atoms number about 100, most common molecules are tens thousands and interactions between them are very complex (e.g. Van der Waals force).

It may be however, that nano and femto technology enable each other as well, as tiny bits of AB-Matter would be marvellous tools for nanomechanical systems to wield to obtain effects unimaginable otherwise.

What time horizon might we face in this quest? The physicist Richard Feynman offered his idea to design artificial matter from atoms and molecules at an American Physical Society meeting at Caltech on December 29, 1959. But only in the last 15 years we have initial progress in nanotechnology. On the other hand progress is becoming swifter as more and better tools become common and as the technical community grows.

Now are in the position of trying to progress from the ancient ‘telega’ haywagon of rural Russia (in analogy, conventional matter composites) to a ‘luxury sport coupe’ (advanced tailored nanomaterials). The author suggests we have little to lose and literal worlds to gain by simultaneously researching how to leap from ‘telega’ to ‘hypersonic space plane’. (Femotech materials and technologies, enabling all the wonders outlined here).

## REFERENCES

(The reader may find some of these articles at the author’s web page <http://www.scribd.com> , <http://arxiv.org> , <http://www.archive.org> , <http://aiaa.org> , search “Bolonkin” and in the books: "Non-Rocket Space Launch and Flight", Elsevier, London, 2005, 488 pages; “New Concepts, Ideas, Innovations in Aerospace, Technology and Human Science”, NOVA, 2006, 502 pages and “Macro-Projects: Environment and Technology”, NOVA 2007, 536 pages; “New Technologies and Revolutionary Projects”, Scribd, 2008, 324 pgs.).

1. Bolonkin A.A., Femtotechnology. Nuclear AB-Matter with Fantastic Properties, *American Journal of Engineering and Applied Sciences*. 2 (2), 2009, p.501-514. Presented as paper AIAA-2009-4620 to 7<sup>th</sup> Annual International Energy Convention Conference, 2-5 August 2009, Denver, CO, USA. [On line]: <http://www.scribd.com/doc/24045154> , <http://www.scribd.com/doc/24046679/> .



2. Bolonkin A.A., Femtotechnology: Design of the Strongest AB-Matter for Aerospace. Presented as paper AIAA-2009-4620 to 45 Joint Propulsion Conference, 2-5 August, 2009, Denver CO, USA. See also closed paper AIAA-2010-1556 in 48 Aerospace Meeting, New Horizons, 4 – 7 January, 2010, Orlando, FL, USA.

<http://www.archive.org/details/FemtotechnologyDesignOfTheStrongestAb-matterForAerospace>

3. Bolonkin A.A., Converting of Matter to Nuclear Energy by AB-Generator. *American Journal of Engineering and Applied Sciences*. 2 (4), 2009, p.683-693. [on line] <http://www.scribd.com/doc/24048466> .

4. Bolonkin A.A., "Non-Rocket Space Launch and Flight", Elsevier, 2005, <http://www.archive.org/details/Non-rocketSpaceLaunchAndFlight>, <http://www.scribd.com/doc/24056182> .

5. Bolonkin A.A., Book "New Concepts, Ideas and Innovation in Aerospace", NOVA, 2006 .<http://www.scribd.com/doc/24057071> .

<http://www.archive.org/details/NewConceptsIfeasAndInnovationsInAerospaceTechnologyAndHumanSciences> .

6. Bolonkin A.A., "Macro-Engineering: Environment and Technology", pp. 299-334, NOVA, 2007.

<http://Bolonkin.narod.ru/p65.htm>, <http://www.scribd.com/doc/24057930> .

<http://www.archive.org/details/Macro-projectsEnvironmentsAndTechnologies> .

7. Bolonkin A.A., "New Technologies and Revolutionary Projects", Scribd, 2008, 324 pgs, <http://www.scribd.com/doc/32744477> ,

<http://www.archive.org/details/NewTechnologiesAndRevolutionaryProjects> .

8. Bolonkin A.A., LIFE. SCIENCE. FUTURE (Biography notes, researches and innovations). Scribd, 2010, 208 pgs. 16 Mb. <http://www.scribd.com/doc/48229884>,

<http://www.archive.org/details/Life.Science.Future.biographyNotesResearchesAndInnovations> .

7

April 2011

Future suspended structures supported by AB-needles



## Chapter 4

# Space Wing Electro Relativistic AB-Ship

### Abstract

Author offers and develops the theory of a new class of space wing electro ship. A biplane wing and an electric field between the wings characterize this space ship. The interstellar and interplanetary mediums contain charged protons and other charged particles. The winged space ship can produce the lift, thrust and drag forces. The density of the space medium is small ( $10^0 - 10^5$  charged particles/cm<sup>3</sup>) but the high ship speed allows creating enough force for maneuvers, turning, acceleration and braking of ship especially at near relativistic speeds. Author shows the ratio of lift force/drag of the space wing electro ship may reach 100 and maneuver of wing space is big advantageous compared to maneuver using conventional rocket methods. In addition the biplane wing easily may be converted into a very efficient engine (brake) using external space matter and achieve something close to simple photon propulsion. That means the proposed wing-brake-engine is the most efficient and technologically realistic space drive available at the present time. The offered wing design allows collecting of particles from a very large space area. The method also allows decreasing the drag of a ship body.

**Key words:** space wing electro apparatus, AB-space ship, flight into space medium, non-rocket space flight, ramjet space engine, electrocraft

### Introduction

A major problem with using rocket propulsion to reach the velocities required for interstellar flight is the enormous amounts of fuel required. Since that fuel must itself be accelerated, this result in an approximately exponential increase in mass as a function of velocity change at non-relativistic speeds, asymptotically tending to infinity as it approaches the speed of light.

In 1960 the physicist Robert W. Bussard proposed an interstellar ramjet engine [1]. Bussard proposed a ramjet variant of a fusion rocket capable of fast interstellar spaceflight, using an enormous magnetic field (ranging from kilometers to many thousands of kilometers in diameter) as a ram scoop to collect and compress hydrogen from the interstellar medium. High speeds force the reactive mass into a progressively constricted magnetic field, compressing it until thermonuclear fusion occurs. The magnetic field then directs the energy as rocket exhaust opposite to the intended direction of travel, thereby accelerating the vessel. In principle, the Bussard ramjet avoids this problem by not carrying fuel with it. An ideal ramjet design could in principle accelerate indefinitely until its mechanism failed. Ignoring drag, a ship driven by such an engine could theoretically accelerate arbitrarily close to the speed of light, and would be a very effective interstellar spacecraft. In practice, since the force of drag produced by collecting the interstellar medium increases approximately as its speed squared at non-relativistic speeds and asymptotically tends to infinity as it approaches the speed of light (taking all measurements from the ship's perspective), any such ramjet would have a limiting speed where the drag equals thrust. To produce positive thrust, the fusion reactor must be capable of producing fusion while still giving the incident ions a net rearward acceleration (relative to the ship).

The collected propellant can be used as reaction mass in a plasma rocket engine, ion rocket engine, or even in an antimatter-matter annihilation powered rocket engine. Interstellar space contains an average of  $10^{-21}$  kg of mass per cubic meter of space, primarily in the form of non-ionized and ionized hydrogen, with smaller amounts of helium, and no significant amounts of other gasses. This means that



the ramjet scoop must sweep  $10^{18}$  cubic meters of space to collect one gram of hydrogen.

The obvious fuel source, the one proposed by Bussard, is fusion of hydrogen, the most common component of interstellar gas. Unfortunately, the proton-proton fusion rate is close to zero for this purpose: protons in the Sun on average survive for a billion years or more before reacting. Accordingly, an interstellar ramjet would have to be powered by other nuclear reactions, but the required isotopes are rare in the interstellar medium.

Bussard ramjet designs that use the collected hydrogen only as reaction mass are sometimes referred to as *ram-augmented* interplanetary or interstellar rockets (RAIR) to distinguish them from the designs that use the collected hydrogen as fuel.

**Discussions of feasibility.** T.A. Heppenheimer [2] analysed Bussard's original suggestion of fusing protons, but found the bremsstrahlung losses from compressing protons to fusion densities was greater than the power that could be produced by a factor of about 1 billion, thus indicating that the proposed version of the Bussard ramjet was infeasible.

There are a lot of principal physical and technology problems which disallow creating the Bussard ramjet. As it is shown in [3] Ch.4, pp.95-104 the ship's magnetic field is spinning up the charged particles which produce their own magnetic field opposed to the ship magnetic field and dramatically decreases it; the outer particles of the ship's ring magnetic field does not collect charged particles and not produce a drag; the collection region of magnetic ring becomes small when ship speed is high (close to a relativistic speed). The braking of particles by a plate (at a short distance) produces dangerous X and  $\gamma$  radiation. The fusion nuclear reactor is very complex, expensive and absent in present time. This itself produces a dangerous nuclear radiation and so on.

**Interstellar medium.** Although space is very empty and the stars in the Milky Way are very far apart, the space between the stars contains a very diffuse medium of gas and dust astronomers call the *interstellar medium (ISM)*. This medium consists of neutral hydrogen gas (HI), molecular gas (mostly H<sub>2</sub>), ionized gas (HII), and dust grains. The Milky Way Galaxy is filled with a very diffuse distribution of neutral hydrogen gas which has a typical density of about 1 atom/cm<sup>3</sup> ( $10^{-24}$ g/cm<sup>3</sup>).

The neutral hydrogen is distributed in clumpy fashion with cool, denser regions that astronomers call "clouds" but which are more like filaments. These regions have a typical temperature of about 100K and a density between 10--100 atoms/cm<sup>3</sup>. Surrounding the clouds is a warmer lower density medium with about 0.1 atom/cm<sup>3</sup> and  $T \sim 1000$ K.

**Molecular Clouds.** Comparatively dense ( $n_{\text{H}_2} > 1000$  molecules/cm<sup>3</sup>), cold ( $T \sim 10$ K) clouds of molecular hydrogen and dust, known as molecular clouds or dark clouds are the birthplaces of stars. We do not detect molecular hydrogen directly, but infer its characteristics from other molecules, most often CO. Over 50 other molecules have been detected including NH<sub>3</sub>, CH, OH, CS and molecules as complex as ethyl alcohol (C<sub>2</sub>H<sub>5</sub>OH - the stuff in whisky) have been found in Milky Way molecular clouds. The Horsehead Nebula (Messier Nebulae, Web Nebulae) to the right is produced by the incursion of a plume of dust from a molecular cloud, covering the lower half of the image, into a region of ionized hydrogen. A Giant Molecular Cloud (GMC) may have a mass of  $10^6 M_{\odot}$  and a diameter of 150 l.y. Within the GMCs are warm dense cores of order 2-3 l.y. in diameter, with  $T \sim 100$ K and densities as high as  $n \sim 10^7$ - $10^9$  molecules/cm<sup>3</sup>. It is in these regions where the star-formation process begins. There are thousands of GMCs in the Milky Way, mostly on the Spiral Arms and concentrated toward the Galactic Center. The total mass of molecular gas is estimated to be about equal to, or perhaps somewhat less ( $\sim 25\%$ ) than, the mass of HI gas.

About 99% of the interstellar medium is gas with about 90% of it in the form of hydrogen (atomic or molecular form), 10% helium, and traces of other elements. H II regions are regions of hot (several thousand K), thin hydrogen emission nebulae that glow from the fluorescence of hydrogen atoms. The roman numeral "II" of H II means that hydrogen is missing one electron. A He III nebula is made of helium gas with two missing electrons. A H I nebula is made of neutral atomic hydrogen. Ultraviolet

light from hot O and B stars ionizes the surrounding hydrogen gas. The famous H II region is the Orion Nebula. Another large H II region is the Lagoon Nebula in the constellation Sagittarius. It is about 5000 light years away and spans 90 by 40 arc minutes in our sky. Converting the angular size to a linear size, the Lagoon Nebula is about 130 by 60 light years in extent (the Orion Nebula is only 29 by 26 light years in size).

**Table 1.** Density different parts of Interstellar medium [1]

Principal Constituents of the ISM				
	Total Mass ( $M_{\odot}$ )	"Cloud" Mass ( $M_{\odot}$ )	Density ( $\text{cm}^{-3}$ )	Temperature (K)
HI gas	$\sim 5 \times 10^9$		0.1-10	100-1000
H <sub>2</sub> gas	$1-5 \times 10^9$	$10^5-10^6$	$10^3-10^5$	$\sim 10$
Dust	$\sim 5 \times 10^7$			$\sim 40$
HII gas		100-1000	$10^3-10^4$	10,000

Next to the Lagoon Nebula on our sky (but closer to us in space) is the Trifid Nebula, so-called because of the dust lanes that trisect the H II region behind them. The image below is nice one to illustrate the three types of nebulae: the red H II region behind a dark dust nebula (showing the effect of the extinction of light) and next to them a blue reflection nebula (showing the preferential scattering of shorter wavelengths).

H II regions also provide a convenient way to map the structure of a galaxy because they are so large and luminous. In our galaxy the H II regions are distributed in a spiral pattern.

The Solar system has a protonic Solar wind having density 10 – 70 protons and speed 400 – 1000 m/s at Earth orbit [4] Ch.13, p.246. The Earth's top atmosphere has about  $10^5$  charged particles/ $\text{cm}^3$  at altitude 200 – 600 km and above [3] Ch.3 p.48. The UV light of star ionizes the hydrogen at a gigantic distance.

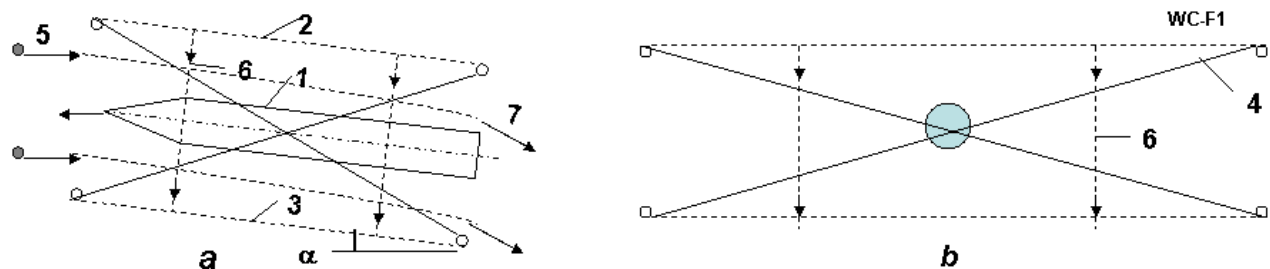
### Description of the offered space wing electro-ship.

The schematic diagram of the offered space wing electro-ship is shown in fig. 1. The ship has body 1, two biplane wings (light grids, nets): top 2 and lower 3 and bracings 4. The grids are charged electricity "+" and "-". They have electric field between them. Number 6 is lines of an electric intensity. The charged space medium 5 (protons, ions, plasma) entrance between wings in flight and wings turn (to deflect) the charged space particles 7 in down and thus produce the lift force. This lift force allows changing the direction of space flight and helping to maneuver the space ship.

The wings may have a perpendicular position to the flight direction. In this case they can work as the efficient propulsion system (engine) or an electric brake of the space ship. When installation is used as wings or engine that consumes electric energy. When they use as the brake, they generate electric energy. The wing grid is made from thin wire and has large cells relative to the wire area. They located along the flight direction and have negligibly small medium drag. They may also be formed as tubes (or balls) from a very thin film covered by electric conductivity layer. In this case the thickness of film

is very small and high energy space particles pierce through them.

The charged space medium (and plasma) is a mixture of the negative (electrons and protons) particles. The mass of electrons is less than the mass of protons by approximately two thousand times. Their acceleration proportionately more than the acceleration of protons. The electrons quickly leave the space between biplane wings. In addition, when the wing has a positive attack angle, the way of positive particles between biplane wings is more than the way of electrons. That way the offered wing produces the lift force and simultaneously the inductive grad 10 shown in fig.2c. The computation of lift force, drag, inductive drag, thrust and brake are discussed in Computation and Estimation section.

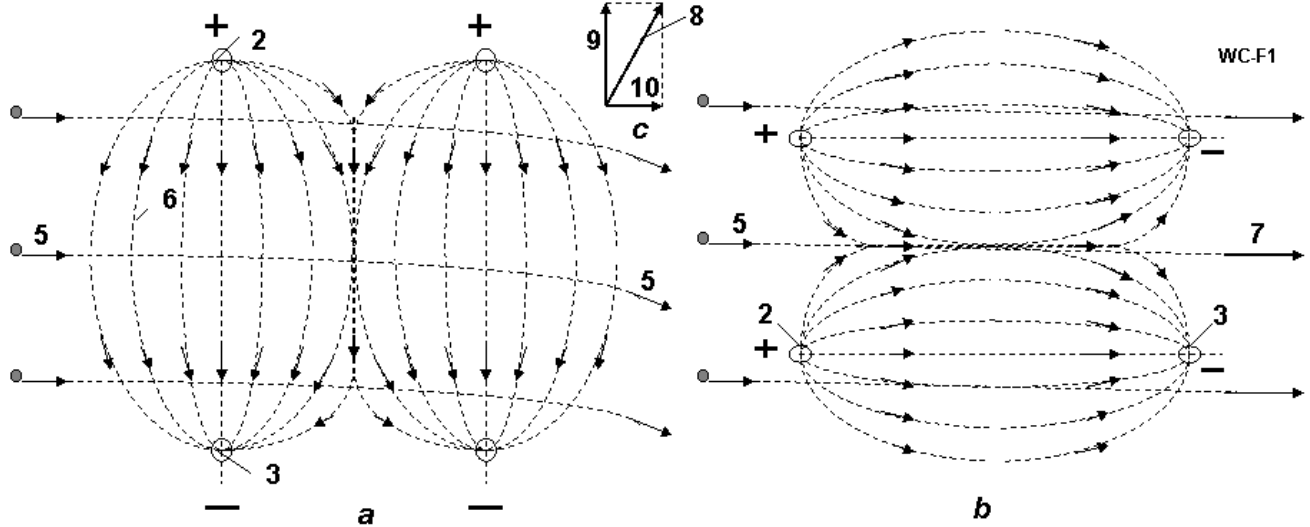


**Fig.1.** Space wing AB-electroship. *a* – site view; *b* – forward view. Notations: 1 – Body of electrocraft; 2 – upper positive charged electric net (upper wing). Nets (grids) 1 and 2 together create the biplane wing in the horizontal position (along the charge flow) and jet-engine in vertical position (perpendicular to charge flow); 3 – lower negative charged electric net (lower wing); 4 – bracing; 5 – space charged particles (in the most cases: proton) or a charged flow; 6 – line of electrical intensity; 7 – deflected flow after wing;  $\alpha$  – attack angle of wing.

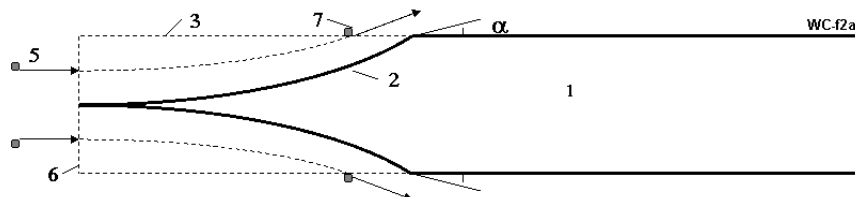
Element of one design of the suggested space wing is shown in fig.2. Fig.2a shows the horizontal position of the wing (vertical position of electric intensity lines relative to the direction of ship flight). In this position the wing deflects down the charged flow and produces the lift force and inductive drag. Fig. 2b shows the vertical position of the wing (horizontal position of electric intensity lines relative to the direction of ship flight). Note, in this position you can **transfer the wing into an electric engine** without turning of wing by a switching-on the voltage between horizontal elements of wing. In this position the wind will be working as propulsion system and produces thrust or drag.

Fig.3 shows the method for decreasing drag of the ship body 1 (fuselage of space ship). Relativistic particles cannot be deflected by sharp edges as the conventional high-speed molecules in aviation. They penetrate into body matter and can produce the radiation and radioactive isotopes. We can only deflect the charged particles by electric fields. There are two grids 2 and 3 having the electric field between them. The positive heavy particle 5 bends its trajectory between grids 2-3 and is deflected (see 7) before contacting the front part of the body in space. The negative particles (electrons) penetrate into the ship body and negatively charge the ship body. This negative charge may be used for charging the negative wing grid, or in the collector of positive particles 4 (**fig.6**), or for production of electricity [4].

The thin film 6 is used as ionizer of neutral particles. They loss the part of its kinetic energy (energy of ionization about 14 eV for hydrogen) but heavy positive particles avoid collision with ship body.

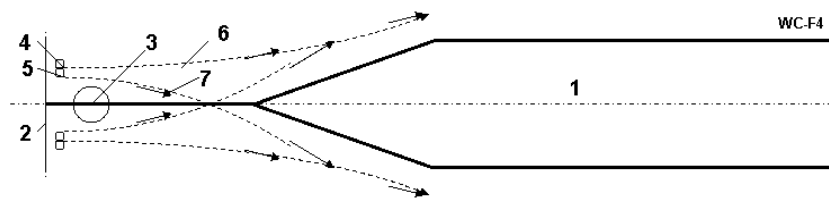


**Fig.2.** Element of space net wing. *a* – horizontal position of the wing or the vertical electric intensity lines; *b* - vertical position of the wing or the horizontal position of intensity lines; *c* – inductive drag of the wing. *Notations:* 7 – accelerated (braked) space charged particles; 8 – wing force; 9 – lift force; 10 – inductive force; other notations are same with fig. 1.



**Fig.3.** Body (fuselage) deflector of the charged particles (reducer of space drag). *Notations:* 1 – ship body (fuselage); 2, 3 – electric grids; 5 – flow of electric charges to a body entrance; 6 – thin film-ionizer. 7 – deflected positive charged particles.

The other design of fuselage deflector is shown in fig.4. Forward of body locates the ionizer from thin film and charged positive ball. The positive ball repels the protons and attractive the electrons. They avoid the collusion with ship body.

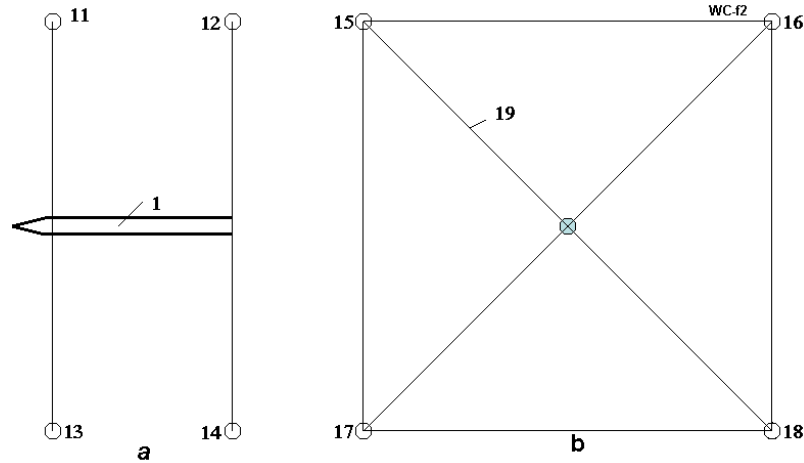


**Fig.4.** Other design of body (fuselage) deflector of the charged particles (reducer of space drag). *Notations:* 1 – ship body (fuselage); 2 – thin film ionizer; 3 – charged positive ball; 4 – charged positive particle (proton); 5 – charged negative particle (electron); 6 – trajectory of positive particle; 7 – trajectory of negative particle.

Fig.5 shows the simplest wing space ship. That has eight charged balls 11 - 18 from thin film covered by conductive layer. The balls are connected to space ship by the thin long wires 19 and rotated around ship. Centrifugal force compensates the attractive force of charged ball and lift force, thrust and drag forces. The ball allows gets an acceptable electric intensity on ball surface ( $< 100$  Mv).

This design allows covering a large space area (up to tens of square km). That allows also easy

conversion of the space wings into propulsion/drag system (without turning or translating the entire system) by switching of electric voltage into chosen other balls from a variety deployed throughout the craft (analogous to firing only certain rockets of a built in reaction control system (RCS) in traditional spacecraft, but with the reaction-mass free consumption of a reaction wheel--and without the reaction wheel's need for periodical purging of momentum.)



**Fig.5.** The simplest wing space AB-electro-craft. *a* – site view; *b* – forward view. Notation: 11 – 18 charged balls; 19 – brackets.

We can use for collection of the positive charged particles (protons) the negatively charged ball offered by author in [4] Ch.13. The ship is having achievable speed of 400 km/sec and the thin ball is having radius 5 m can collect the protons from area in 10 – 60 km in Solar System. This design of wing space ship is shown in fig.6. Here 4 is ball, 5 – electrostatic deflector of flow, 6 – electrical accelerator (brake).

The wing space ship can have the UV laser 2, which ionizes the neutral atoms ahead of ship. That allows the ship to have the lift force, thrust and brake in most areas of interstellar media. The stars having predominant UV light in their emission spectra ionize the interstellar hydrogen at gigantic distances. The requested energy for ionization of hydrogen H equals 13 eV. The energy of relativistic H particles is  $Mv$ . It is more profitable to ionize and deflect H from way than spend engine energy for compensation of ship drag.

## Theory, computations and estimation of a flight the wing space ship

**1. Common relations.** The relativistic theory [5] asserts the measurement of time  $t$ , speed  $v$  and distance  $S$  of moving object made a immobile observer (on Earth) and observer located in object (astronaut of space ship) gives the different result. The theory gives the following relations between them

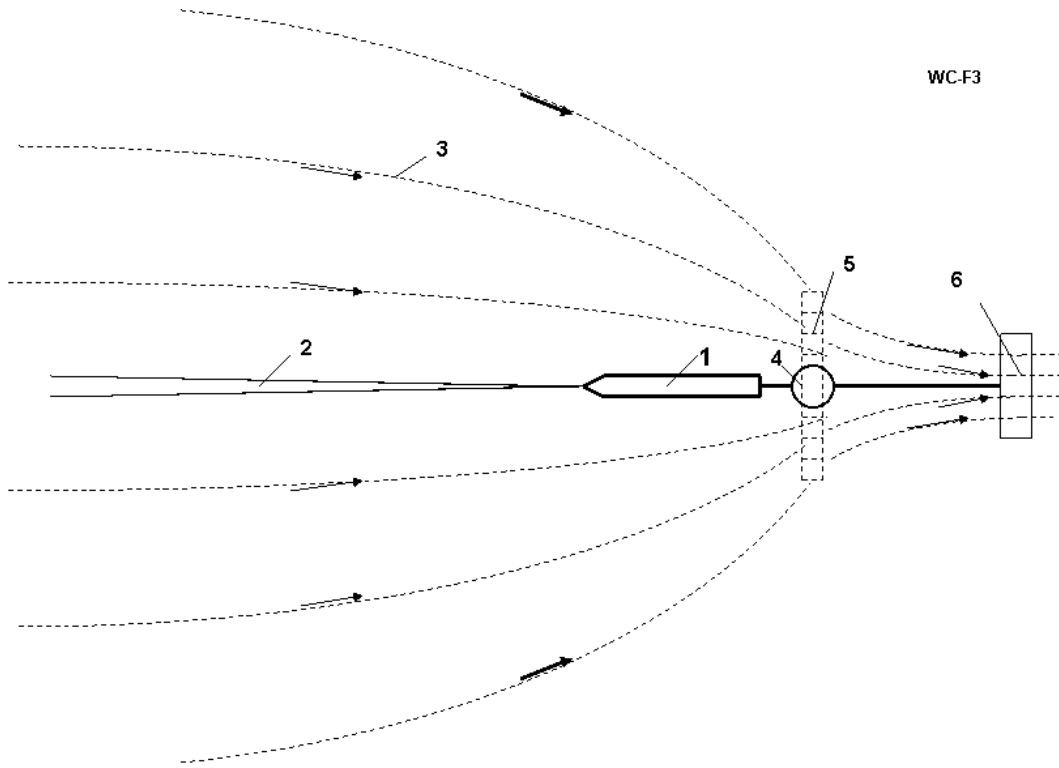
$$\frac{v}{c} = th\left(\frac{v_e}{c}\right), \quad \frac{dt}{dt_e} = ch\left(\frac{v_e}{c}\right), \quad \frac{ds}{ds_e} = \left[ ch\left(\frac{v_e}{c}\right) \right] / \left(\frac{v_e}{c}\right)^2, \quad (1)$$

where  $c = 3 \cdot 10^8$  m/s is light speed;  $v$  is speed of the moving object measured by immobile observer, m/s;  $v_e$  is speed measured by astronaut by calculation the acceleration and self time, m/s;  $t$  is time, sec;  $s$  is length, m. The subscript 'e' means the value is measured by astronaut. The other values are measured by Earth observer. The  $th$ ,  $ch$ ,  $sh$  are hyperbolic tangent, cosine and sine. Note the speed  $v_e$  calculated by astronaut may be any, in particular,  $v_e > c$ . The hyperbolic  $th x \leq 1$ .

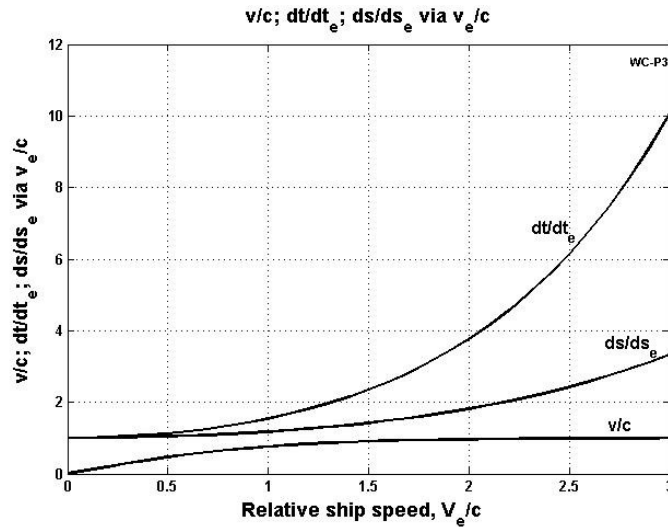
The hyperbolic  $th$ ,  $ch$ ,  $sh$  may be computed throw conventional function  $e^x$

$$sh x = \frac{e^x - e^{-x}}{2}, \quad chx = \frac{e^x + e^{-x}}{2}, \quad thx = \frac{e^x - e^{-x}}{e^x + e^{-x}}. \quad (2)$$

For small  $v_e/c \ll 1$  the  $v \approx v_e, t \approx t_e, s \approx s_e$ . The computations of magnitudes (1) presented in fig.7.



**Fig.6.** Space wing ship having the laser beam ionizer 2 and the electrostatic collector 4. *Notations:* 1 – space ship; 2 UV laser beam ionizer; 3 – trajectories of positive charged particles; 4 - negative charged thin film ball; 5 – electrostatic deflector of flow; 6 – electrical accelerator (brake).



**Fig.7.** Ratio speeds, times and lengths measured astronaut and Earth observer.

**2. Case of constant acceleration  $a$ .** In this case the relativistic equations may be integrated and we get the next relations between the time, speed and distance measured by Earth observer and astronaut:

$$t = 2 \left[ \frac{S}{a} \left( 1 + \frac{aS}{4c^2} \right) \right]^{0.5}, \quad t_e = \frac{2c}{a} \left[ ch^{-1} \left( 1 + \frac{aS}{2c^2} \right) \right], \quad t = \frac{2c}{a} \ln \left[ \frac{at_e}{c} + \sqrt{1 + \left( \frac{at_e}{c} \right)^2} \right], \quad (3)$$

where  $a = \text{const}$  acceleration of space ship measured by astronaut,  $\text{m/s}^2$ .  $S$  is distance,  $\text{m}$ .

The speed and distance are (in  $t_e = t = 0$ , values  $v(0) = S(0) = 0$ ):

$$v = \frac{at_e}{\sqrt{1 + (at_e/c)^2}}, \quad S = \frac{c^2}{a} \left[ \sqrt{1 + \left( \frac{at_e}{c} \right)^2} - 1 \right], \quad \bar{m} = \exp \left[ 2ch^{-1} \left( 1 + \frac{aS}{2c^2} \right) \right], \quad (4)$$

where  $\bar{m} = M / M_0$  is the rest of the relative mass of ship moved by the photon engine.

Let us consider the hypothetic flight to star system Alfa-Centaur (Alpha Centauri) located at a distance 4.3 light years from Earth with constant Earth acceleration  $a = 10 \text{ m/s}^2$ . The first half of distance the ship accelerates, the second it brakes. Then the maximum speed of ship will be  $v/c = 0.95$ , the astronaut time of flight will be 7.3 years, the Earth time will be 12 years. The radioed (beamed) information sent by astronauts about Alfa-Centaur (Alpha Centauri) will reached the Earth after 4.3 years.

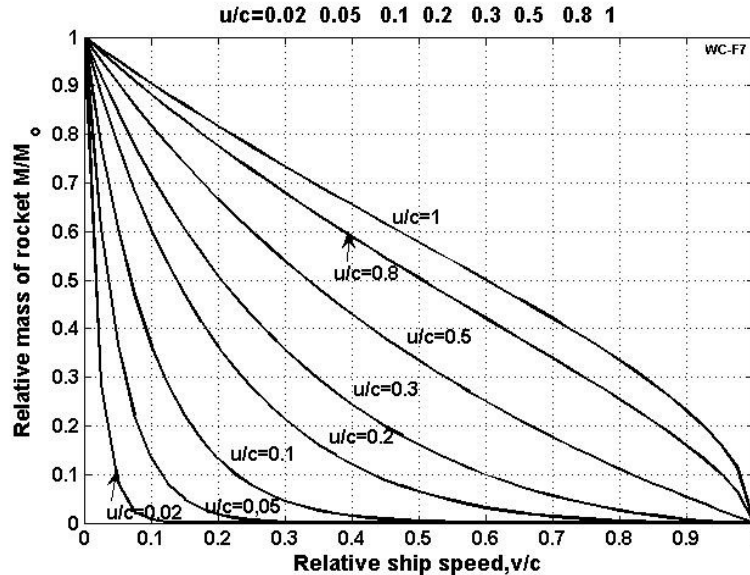
**3. Relative consumption of mass by rocket engine is**

$$\bar{m} = \left( \frac{1 - \bar{v}}{1 + \bar{v}} \right)^{1/(2\bar{u})}, \quad (5)$$

Where  $\bar{v} = v/c$  is relative ship speed;  $\bar{u} = u/c$  is relative speed of an exhaust mass (gas, photons, protons) measured by astronaut;  $\bar{m} = M / M_0$ ;  $M_0$  –initial mass of rocket,  $\text{kg}$ .

The photon engine having  $\bar{u} = u/c = 1$  spends about 40% of rocket mass for reaching relative speed  $\bar{v} = 0.5c = 150\,000 \text{ km/s}$ .

For  $v/c \ll 1$  the equation (5) became as the well-known equation  $\bar{m} = e^{-v/u}$ . Computations of the equation (5) are presented in fig.8.



**Fig.8.** Relative mass of rocket via relative speed of rocket and relative speed of exhaust mass.

**4. The dynamic pressure (drag) of space ship equals**

$$p_e = \rho_e c^2 sh^2(v_e/c), \quad \text{for } v_e/c \ll 1 \quad p_e = \rho_e v^2, \quad \text{for } v_e \gg 1 \quad p_e = 0.25 \rho_e c^2 e^{2v_e/c}, \quad (6)$$

where  $p_e$  is dynamic pressure,  $\text{N/m}^2$ ;  $\rho_e$  is density of space medium,  $\text{kg/m}^3$  (mass of proton is  $m_p = 1.67 \cdot 10^{-27} \text{ kg}$ ). The computation of equation (6) are presented in fig.9.



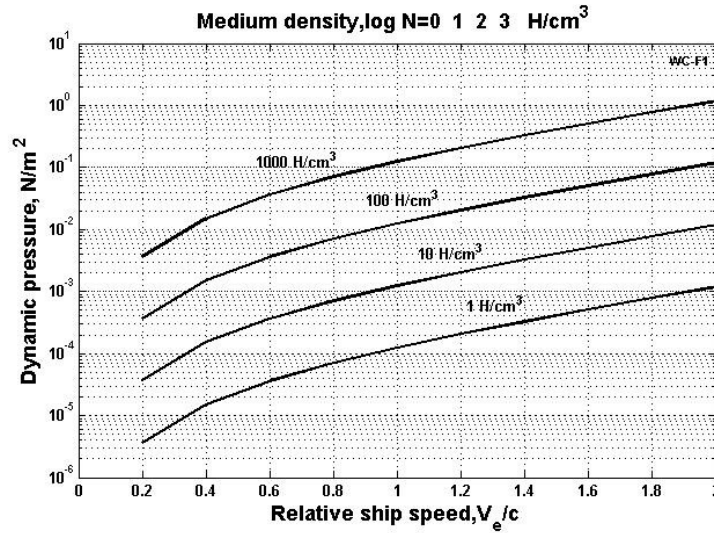


Fig.9. Dynamic pressure (drag) via relative space ship and media density.

**5. The thrust of the ramjet engine.** The thrust of unit ( $m^2$ ) of an entrance surface  $F$  [ $m^2$ ] in case of photon engine and the most efficiency using is

$$P_e / F = \rho_e c^2 \left[ \frac{1}{th(v_e/c)} - 1 \right] sh^2(v_e/c), \quad \text{for } v_e/c \ll 1 \quad P_e / F = \rho_e v_e c,$$

$$\text{for } v_e/c \gg 1 \quad P_e / F = \frac{1}{2} \rho_e c^2, \quad (7)$$

where  $P_e$  is thrust, N. The computations of equation (7) are presented in fig.10.

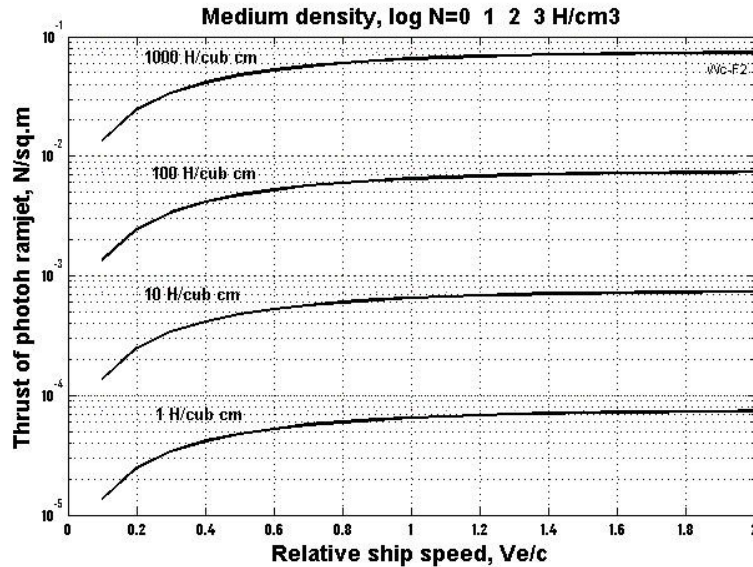


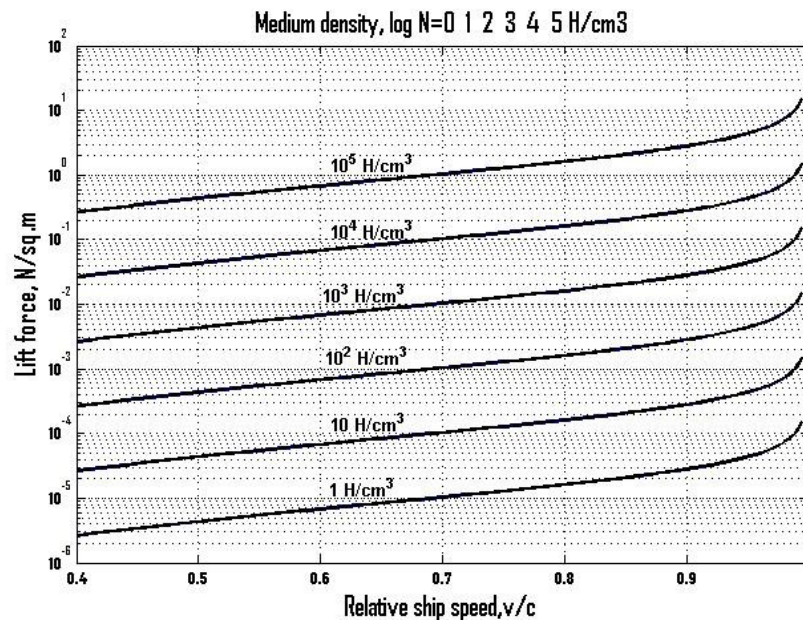
Fig.10. Thrust of photon ramjet engine via relative ship speed  $v_e/c$  and number protons (H) in  $1\text{cm}^3$ .

**6. Lift force and inductive drag.** The space wing shown in fig.1 (when one deflects a flow) produces the drag shown in fig.2c. The value of drag depends from angle of deflected flow. This angle  $\beta$  and inductive drag  $D_i$  [ $N/m^2$ ], lift force  $L$  [ $N/m^2$ ] approximately equals

$$\beta \approx V/v, \text{ where } V \approx \left(2 \frac{q}{m} U\right)^{1/2}, \quad s \approx \frac{V^2}{2a_p}, \quad E \approx qU, \quad D_i \approx \frac{\beta}{2} L, \quad L \approx \frac{\beta \rho_e v^2}{\sqrt{1-v^2/c^2}}, \quad (8)$$

where  $V$  is vertical (along electric tensile lines) speed in exit of wing, m/s;  $q$  is charge of particles, for proton  $q = 1.6 \cdot 10^{-19}$  C;  $m$  is mass of particles, for proton  $m_p = 1,67 \cdot 10^{-27}$  kg;  $U$  is change of electric voltage along particle way, V;  $s$  – way of particle along electric lines, m;  $a_p$  – acceleration of particle,  $m/s^2$ ;  $E$  – energy of particle along electric lines, eV. Conventionally  $V/c \ll 1$ . Acceleration of particle equals  $a_p \approx qE_p/m$ , where  $E_p$  is electric intensity, V/m;  $L$  is lift force,  $N/m^2$ . Lift force, media density and speed  $v$  are related to area  $F$  of the entrance into biplane wing.

The ratio  $k = L/D$  (where  $L$  is lift force,  $D$  is a full drag) can reach up  $k \approx 2/\beta \approx 100$  (conventional airplane has  $k$  about 12÷15). That means using wing space ship for maneuver is more profitable then rocket engine. The computations lift force  $L$  of equation (8) via relative ship speed and the media density (number of protons  $H$  in  $1 \text{ cm}^3$ ) are presented in fig.11.



**Fig.11.** Relative lift force  $L$  [ $N/m^2$ ] of wing ship via relative ship speed  $v/c$  and numbers of protons [ $H/cm^3$ ] in space media,  $\beta = 0.1$ .

**7. Drag of ship body.** It is very efficient using the electrostatic field (fig.3, 4) for decreasing the drag of ship body (fuselage). Proton is heavier by 1836 times than electron. Theoretically we can decrease the drag by the same factor spending but small electric energy.

**8. Collector of particles.** Electrostatic collector offered and developed by author in [4] Ch.13. That allows to collect charged particles from a gigantic area and to get matter for the ship.

## Conclusion

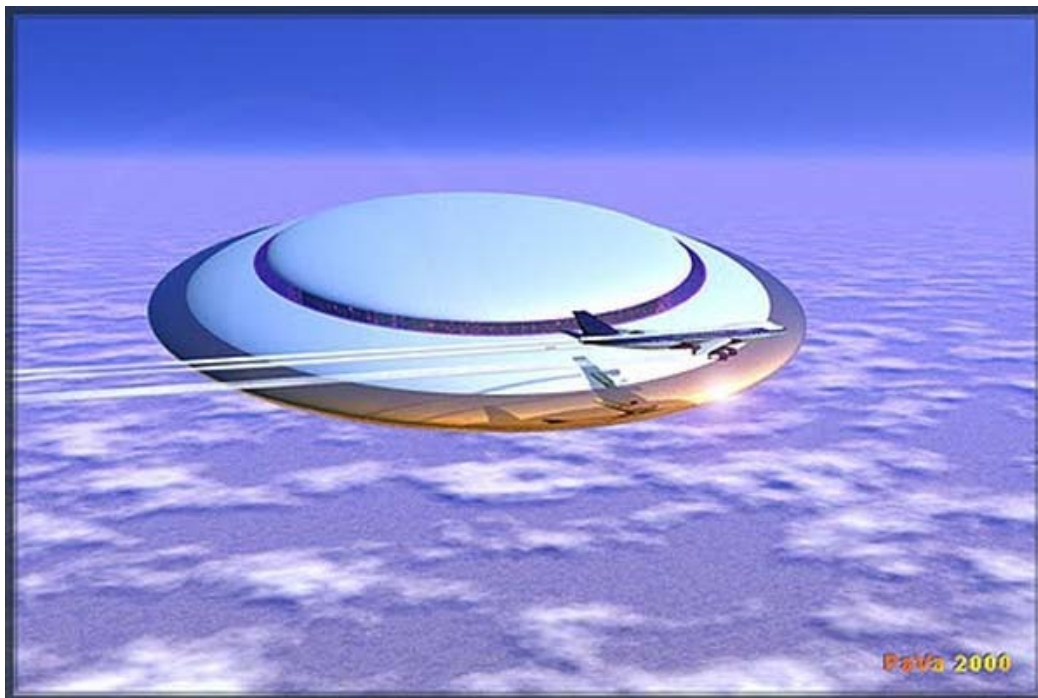
Author offers and develops a new wing space relativistic apparatus (space ship). And the propulsion system uses the electric energy. That apparatus allows changing the direction of flight and maneuvering (include orientation) of the space ship without using the rocket engine. He also offers the electrostatic method for decreasing the drag of ship fuselage and collects the charged particles from a huge area. That increases the efficiency of the wing ship and the ramjet relativistic propulsion system by thousands of times.

## References

1. Wikipedia. Bussard Ramjet. <http://wikipwdia.org> .
2. Heppenheimer, T.A. (1978). "On the Infeasibility of Interstellar Ramjets". *Journal of the British Interplanetary Society* **31**.
3. Bolonkin A.A., New Concepts, Ideas and Innovations in Aerospace, Technology and Human Sciences, NOVA, USA 2007.
4. Bolonkin A.A., Non-Rocket Space Launch and Flight, Elsevier, London, 2006.
5. Зингер Е., К механике фотонных ракет, Москва, Издательство ИЛ, 1968. Translation from the German: Sanger E., Zur mechanik der photonen-stranlantriebe, Verlag Munchen, 1966.

Further reading:

- 6) "Macro-Projects: Environments and Technologies", by A,Bolonkin, R.Cathcart, NOVA, 2007, 536 pgs. <http://www.scribd.com/doc/24057930> .  
<http://www.archive.org/details/Macro-projectsEnvironmentsAndTechnologies>
- 7) "New Technologies and Revolutionary Projects", by A. Bolonkin, Scribd, 2008, 324 pgs,  
<http://www.scribd.com/doc/32744477> ,  
<http://www.archive.org/details/NewTechnologiesAndRevolutionaryProjects>,  
<http://technica-molodezhi.ru/docs/Bolonkin/FIL13053195760N960350001/>
- 8) LIFE. SCIENCE. FUTURE (Biography notes, researches and innovations), by A. Bolonkin, Scribd, 2010, 208 pgs. 16 Mb.  
<http://www.scribd.com/doc/48229884>,  
<http://www.archive.org/details/Life.Science.Future.biographyNotesResearchesAndInnovations>
- 9) Universe, Human Immortality and Future Human Evaluation. By A. Bolonkin, Scribd. 2010r., 4.8 Mb.  
<http://www.archive.org/details/UniverseHumanImmortalityAndFutureHumanEvaluation>,  
<http://www.scribd.com/doc/52969933/>



## Chapter 5

# Wireless Transfer of Electricity from Continent to Continent

### Abstract

Author offers collections from his previous research of the revolutionary new ideas: wireless transferring electric energy in long distance – from one continent to other continent through Earth ionosphere and storage the electric energy into ionosphere. Early he also offered the electronic tubes as the method of transportation of electricity into outer space and the electrostatic space 100 km towers for connection to Earth ionosphere.

Early it is offered connection to Earth ionosphere by 100 km solid or inflatable towers. There are difficult for current technology. In given work the research this connection by thin plastic tubes supported in atmosphere by electron gas and electrostatic force. Building this system is cheap and easy for current technology.

The computed project allows to estimate the possibility of the suggested method.

**Key words:** transferring of electricity in space; transfer of electricity to spaceship, Moon, Mars; plasma MagSail; electricity storage; ionosphere transfer of electricity.

### Introduction

The production, storage, and transference of large amounts of electric energy is an enormous problem for humanity. These spheres of industry are search for, and badly need revolutionary ideas. If in production of energy, space launch and flight we have new ideas (see [1]-[15]), the new revolutionary ideas in transferring and storage energy are only in the works [1-6].

Important Earth mega-problem is efficient transfer of electric energy long distances (intra-national, international, intercontinental). The consumption of electric energy strongly depends on time (day or night), weather (hot or cold), from season (summer or winter). But electric station can operate most efficiently in a permanent base-load generation regime. We need to transfer the energy a far distance to any region that requires a supply in any given moment or in the special hydro-accumulator stations. Nowadays, a lot of loss occurs from such energy transformation. One solution for this macro-problem is to transfer energy from Europe to the USA during nighttime in Europe and from the USA to Europe when it is night in the USA. Another solution is efficient energy storage, which allows people the option to save electric energy.

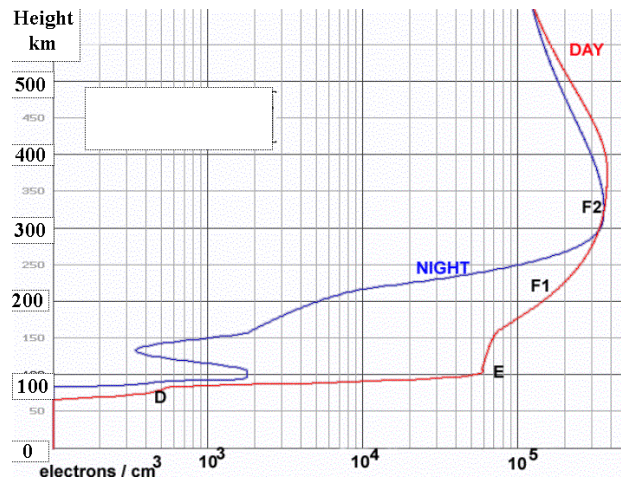
The storage of a big electric energy can help to solve the problem of cheap space launch. The problem of an acceleration of a spaceship can be solved by use of a new linear electrostatic engine suggested in [10] or Magnetic Space Launcher offered in [11]. However, the cheap cable space launch offered by author [12] requires use of gigantic energy in short time period. (It is inevitable for any launch method because we must accelerate big masses to the very high speed -  $8 \div 11$  km/s). But it is impossible to turn off whole state and connect all electric station to one customer. The offered electric energy storage can help solving this mega-problem for humanity.

The idea of wireless transfer energy through ionosphere was offered and researched by author in [1 - 6]. For connection to Earth ionosphere offered the 100 km solid, inflatable, electrostatic or kinetic towers [7 - 9]. But it is expensive and difficult for current technology.

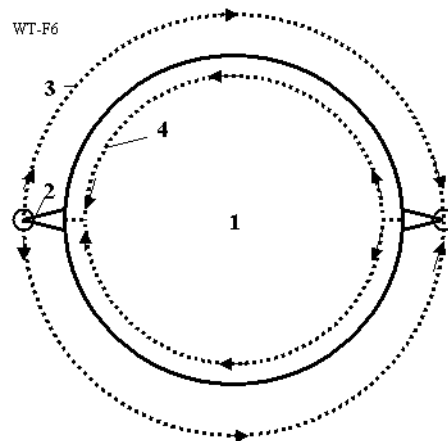
### Wireless transferring of electric energy in Earth.

It is interesting the idea of energy transfer from one Earth continent to another continent without wires. As it is known the resistance of infinity (very large) conducting medium does not depend from distance. That is widely using in communication. The sender and receiver are connected by only one wire, the other wire is Earth. The author offers to use the Earth's ionosphere as the second plasma cable. It is known the Earth has the first ionosphere layer *E* at altitude about 100 km (Fig. 1). The concentration of electrons in this layer reaches  $5 \times 10^4$   $1/\text{cm}^3$  in daytime and  $3.1 \times 10^3$   $1/\text{cm}^3$  at night (Fig. 1). This layer can be used as a conducting medium for transfer electric energy and communication in any point of the Earth. We need minimum two space 100 km. towers (Fig. 2). The cheap optimal inflatable, kinetic, and solid space towers are offered and researched by author in [6-9]. Additional innovations are a large inflatable conducting balloon at the end of the tower and big conducting plates in a sea (ocean) that would dramatically decrease the contact resistance of the electric system and conducting medium.

Theory and computation of these ideas are presented in Macroprojects section.



**Fig.1.** Concentration/ $\text{cm}^3$  of electrons (= ions) in Earth's atmosphere in the day and night time in the D, E, F1, and F2 layers of ionosphere.



**Fig.2.** Using the ionosphere as conducting medium for transferring a huge electric energy between continents and as a large storage of the electric energy. Notations: 1 - Earth, 2 - space tower (or electron tube) about 100 km of height, 3 - conducting *E* layer of Earth's ionosphere, 4 - back connection through Earth.



However the solid 100 km space towers are very expensive. Main innovation in this work is connection to ionosphere by cheap film tube filled by electron gas.

### **Electronic tubes**

The author's first innovations in electrostatic applications were developed in 1982-1983 [1]-[3]. Later the series articles of this topic were published in [4]-[15]. In particular, in the work [4-5] was developed theory of electronic gas and its application to building (without space flight!) inflatable electrostatic space tower up to the stationary orbit of Earth's satellite (GEO).

In given work this theory applied to special inflatable electronic tubes made from thin insulator film. It is shown the charged tube filled by electron gas is electrically neutral, that can has a high internal pressure of the electron gas.

The main property of AB electronic tube is a very low electric resistance because electrons have small friction on tube wall. (In conventional solid (metal) conductors, the electrons strike against the immobile ions located in the full volume of the conductor.). The abnormally low electric resistance was found along the lateral axis only in nanotubes (they have a tube structure!). In theory, metallic nanotubes can have an electric current density (along the axis) more than 1,000 times greater than metals such as silver and copper. Nanotubes have excellent heat conductivity along axis up 6000 W/m·K. Copper, by contrast, has only 385 W/m·K. The electronic tubes explain why there is this effect. Nanotubes have the tube structure and electrons can free move along axis (they have only a friction on a tube wall).

More over, the moving electrons produce the magnetic field. The author shows - this magnetic field presses against the electron gas. When this magnetic pressure equals the electrostatic pressure, the electron gas may not remain in contact with the tube walls and their friction losses. The electron tube effectively becomes a superconductor for any surrounding temperature, even higher than room temperature! Author derives conditions for it and shows how we can significantly decrease the electric resistance.

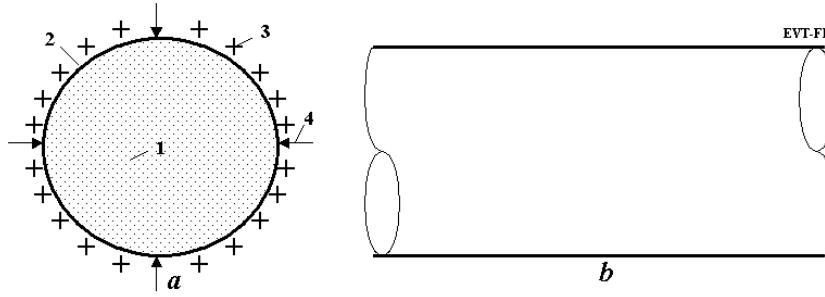
### **Description, Innovations, and Applications of Electronic tubes.**

An electronic AB-Tube is a tube filled by electron gas (fig.3). Electron gas is the lightest gas known in nature, far lighter than hydrogen. Therefore, tubes filled with this gas have the maximum possible lift force in atmosphere (equal essentially to the lift force of vacuum). The applications of electron gas are based on one little-known fact – the electrons located within a cylindrical tube having a positively charged cover (envelope) are in neutral-charge conditions – the total attractive force of the positive envelope plus negative contents equals zero. That means the electrons do not adhere to positive charged tube cover. They will freely fly into an AB-Tube. It is known, if the Earth (or other planet) would have, despite the massive pressures there, an empty space in Earth's very core, any matter in this (hypothetical!) cavity would be in a state of weightlessness (free fall). All around, attractions balance, leaving no vector 'down'.

Analogously, that means the AB-Tube is a conductor of electricity. Under electric tension (voltage) the electrons will collectively move without internal friction, with no vector 'down' to the walls, where friction might lie. In contrast to movement of electrons into metal (where moving electrons impact against a motionless ion grate). In the AB-Tube we have only electron friction about the tube wall. This friction is significantly less than the friction electrons would experience against ionic structures— and therefore so is the electrical resistance.

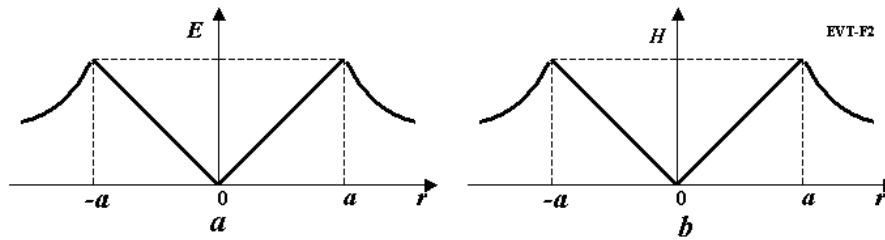
When the density of electron gas equals  $n = 1.65 \times 10^{16}/r \text{ 1/m}^3$  (where  $r$  is radius of tube, m), the electron gas has pressure equals atmospheric pressure 1 atm (see research below). In this case the tube cover may be a very thin—though well-sealed-- insulator film. The outer surface of this film is charged

positively by static charges equal the electron charges and AB-Tube is thus an electrically neutral body.



**Fig.3.** Electronic vacuum AB-Tube. *a)* Cross-section of tube. *b)* Side view. *Notation:* 1 – Internal part of tube filled by free electrons; 2 – insulator envelope of tube; 3 – positive charges on the outer surface of envelope (over this may be an additional film-insulator); 4 – atmospheric pressure.

Moreover, when electrons move into the AB-Tube, the electric current produces a magnetic field (fig.4). This magnetic field compresses the electron cord and decreases the contact (and friction, electric resistance) electrons to tube walls. In the theoretical section is received a simple relation between the electric current and linear tube charge when the magnetic pressure equals to electron gas pressure  $i = c\tau$  (where  $i$  is electric current, A;  $c = 3 \times 10^8$  m/s – is the light speed;  $\tau$  is tube linear electric charge, C/m). In this case the electron friction equals zero and AB-Tube becomes **superconductive at any outer temperature**. Unfortunately, this condition requests the electron speed equals the light speed. It is, however, no problem to set the electron speed very close to light speed. That means we can make the electric conductivity of AB-Tubes very close to superconductivity almost regardless of the outer temperature.



**Fig. 4.** Electrostatic and magnetic intensity into AB-Tube. *a)* Electrostatic intensity (pressure) via tube radius. *b)* Magnetic intensity (pressure) from electric current versus tube radius.

### Theory of Plasma Transfer for Electric Energy, Estimations and Computations Long Distance Wireless Transfer of Electricity on Earth.

The transferring of electric energy from one continent to other continent through ionosphere and the Earth surface is described again. For this transferring we need two space towers of 100 km height, the towers must have a big conducting ball at their top end and underground (better, underwater) plates for decreasing the contact electric resistance (a good Earth ground). The contacting ball is a large (up to 100 - 200 m diameter) inflatable gas balloon having a conductivity layer (covering, or coating).

Let us to offer the method which allows computation of the parameters and possibilities of this electric line.

The electric resistance and other values for a conductive medium can be estimated by the equations:

$$R = \frac{U}{I} = \frac{1}{2\pi a\lambda}, \quad W = IU = 2\pi a\lambda U^2, \quad E_a = \frac{U}{2a}, \quad (1)$$



where  $R$  is the electric resistance of a conductive medium,  $\Omega$  (for sea water  $\rho = 0.3 \Omega\text{m}$ );  $a$  is the radius of the contacting (source and receiving sphere) balloon, m;  $\lambda$  is the electric conductivity,  $(\Omega\text{m})^{-1}$ ;  $E_a$  is electric intensity on the balloon surface, V/m.

The conductivity  $\lambda$  of the  $E$ -layer of Earth's ionosphere as a rare ionized gas can be estimated by the equations:

$$\lambda = \frac{ne^2\tau}{m_e}, \quad \text{where } \tau = \frac{L}{v}, \quad L = \frac{kT_k}{\sqrt{2\pi r_m^2 p}}, \quad v^2 = \frac{8kT_k}{\pi m_e}, \quad (2)$$

where  $n = 3.1 \times 10^9 \div 5 \times 10^{11} \text{ 1/m}^3$  is density of free electrons in  $E$ -layer of Earth's ionosphere,  $1/\text{m}^3$ ;  $\tau$  is the time of electrons on their track, s;  $L$  is the length traversed by electrons on their track, m;  $v$  is the average electron velocity, in m/s;  $r_m = 3.7 \times 10^{-10}$  (for hydrogen  $\text{N}_2$ ) is diameter of gas molecule, m;  $p = 3.2 \times 10^{-3} \text{ N/m}^2$  is gas pressure for altitude 100 km,  $\text{N/m}^2$ ;  $m_e = 9.11 \times 10^{-31}$  is mass of electrons, kg.

The transfer power and efficiency are

$$W = IU, \quad \eta = 1 - R_c / R, \quad (3)$$

where  $R_c$  is common electric resistance of conductivity medium,  $\Omega$ ;  $R$  is total resistance of the electric system,  $\Omega$ .

See the detailed computations in the Macro-Projects section.

*Earth's ionosphere as the gigantic storage of electric energy.* The Earth surface and Earth's ionosphere is gigantic spherical condenser. The electric capacitance and electric energy storied in this condenser can be estimated by equations:

$$C = \frac{4\pi\epsilon_0}{1/R_0 - 1/(R_0 + H)} \approx 4\pi\epsilon_0 \frac{R_0^2}{H}, \quad E = \frac{CU^2}{2}, \quad (4)$$

where  $C$  is capacity of condenser, C;  $R_0 = 6.369 \times 10^6 \text{ m}$  is radius of Earth;  $H$  is altitude of  $E$ -layer, m;  $\epsilon_0 = 8.85 \times 10^{-12} \text{ F/m}$  is electrostatic constant;  $E$  is electric energy, J.

The leakage currency is

$$i = \frac{3\pi\lambda_a R_0^2}{H} U, \quad \lambda_a = n_a e \mu, \quad R_a = \frac{H}{4\pi\lambda_a R_0^2}, \quad t = CR_a, \quad (5)$$

where  $i$  leakage currency, A;  $\lambda_a$  is conductivity of Earth atmosphere,  $(\Omega\text{m})^{-1}$ ,  $n_a$  is free electron density of atmosphere,  $1/\text{m}^3$ ;  $\mu = 1.3 \times 10^{-4}$  (for  $\text{N}_2$ ) is ion mobility,  $\text{m}^2/(\text{sV})$ ;  $R_a$  is Earth's atmosphere resistance,  $\Omega$ ;  $t$  is time of discharging in  $e = 2.73$  times, s.

## Theory and Computation of Electronic Tube

Below the interested reader may find the evidence of main equations, estimations, and computations.

### 1. Relation between the linear electric charge of tube and electron gas pressure on tube surface:

$$p = \frac{\epsilon_0 E^2}{2}, \quad E = k \frac{2\tau}{r}, \quad \epsilon_0 = \frac{1}{4\pi k}, \quad \tau = \sqrt{\frac{2\pi r p}{k}}, \quad (6)$$

where  $p$  is electron pressure,  $\text{N/m}^2$ ;  $\epsilon_0 = 8.85 \times 10^{-12} \text{ F/m}$  –electrostatic constant;  $k = 9 \times 10^9 \text{ Nm}^2/\text{C}^2$  is electrostatic constant;  $E$  is electric intensity, V/m;  $\tau$  is linear charges of tube, C/m;  $r$  is radius of tube, m.

Example, for atmospheric pressure  $p = 10^5 \text{ N/m}^2$  we receive  $E = 1.5 \times 10^8 \text{ V/m}$ , N/C, the linear charge  $\tau = 0.00833r \text{ C/m}$ .

### 2. Density of electron (ion) in $1 \text{ m}^3$ in tube.

$$n = \frac{\tau}{\pi r^2 e} = \frac{1}{2\pi e k} \frac{E}{r} = 1.1 \cdot 10^8 \frac{E}{r}, \quad (7)$$

$$M_e = m_e n, \quad M_i = \mu n_p n, \quad \mu = \frac{m_i}{m_p},$$

where  $n$  is charge (electron or ion) density,  $1/\text{m}^3$ ;  $e = 1.6 \times 10^{-19}$  C is charge of electron;  $m_e = 9.11 \times 10^{-31}$  is mass of electron, kg;  $m_p = 1.67 \times 10^{-27}$  is mass of proton, kg;  $M_e$  is mass density of electron,  $\text{kg}/\text{m}^3$ ;  $M_i$  is mass density of ion,  $\text{kg}/\text{m}^3$ .

For electron pressure 1 atm the electron density (number particles in  $\text{m}^3$ ) is  $n = 1.65 \times 10^{16}/r$ .

**3. Electric resistance of AD-tube.** We estimate the friction of electron about the tube wall by gas-kinetic theory

$$F_B = \eta_B S V, \quad \eta_B = \frac{1}{6} \rho V, \quad \rho = m_e n,$$

$$\bar{F} = \frac{F}{S} = \frac{1}{6} m_e n V^2, \quad V = \frac{j}{en} = \frac{i}{en\pi r^2}, \quad (8)$$

where  $F_B$  is electron friction, N;  $\eta_B$  is coefficient of friction;  $S$  is friction area,  $\text{m}^2$ ;  $V$  is electron speed,  $\text{m}/\text{s}$ ;  $\rho$  is density of electron gas,  $\text{kg}/\text{m}^3$ ;  $\bar{F}$  is relative electron friction,  $\text{N}/\text{m}^2$ ;  $j$  is current density,  $\text{A}/\text{m}^2$ .

**4. Electric loss.** The electric loss (power) into tube is

$$P_T = \bar{F}_B S V, \quad S = 2\pi r L, \quad P_T = \frac{1}{3} \pi m_e n r L V^3,$$

$$P_T = \frac{m_e}{3e^3 \pi^2} \frac{i^3 L}{n^2 r^5} = 7.5 \cdot 10^{24} \frac{i^3 L}{n^2 r^5} \quad [W], \quad (9)$$

where  $P_T$  is electric loss, W;  $L$  is tube length, m;  $i$  is electric current, A.

**5. Relative electric loss is**

$$\bar{P}_T = \frac{P_T}{P}, \quad P = iU, \quad \bar{P}_T = \frac{m_e}{3\pi^2 e^3} \frac{i^2}{n^2 r^5} \frac{L}{U} = 7.5 \cdot 10^{24} \frac{i^2}{n^2 r^5} \frac{L}{U} = 7.4 \cdot 10^{25} \frac{j^2}{n^2 r} \frac{L}{U}, \quad (10)$$

Compare the relative loss the offered electric (tube) line and conventional electric long distance line. Assume the electric line have length  $L = 2000$  km, electric voltage  $U = 10^6$  V, electric current  $i = 300$  A, atmospheric pressure into tube. For offered line having tube  $r = 1$  m the relative loss equals  $\bar{P}_T = 0.005$ . For conventional electric line having cross section copper wire  $1 \text{ cm}^2$  the relative loss is  $\bar{P}_T = 0.105$ . That is in 21 times more than the offered electric line. The computation of Equation (10) for atmospheric pressure and for ratio  $L/U = 1$  are presented in fig. 5. As you see for electric line  $L = 1000$  km, voltage  $U = 1$  million V, tube radius  $r = 2.2$  m, the electric current  $i = 50$  A, the relative loss of electric power is one/millionth ( $10^{-6}$ ), (only 50 W for transmitted power 50 millions watt!). For connection Earth's surface with ionosphere we need only 100 km electronic tube in 100 km electrostatic tower [6].

Moreover, the offered electric line is cheaper by many times, may be levitated into the atmosphere at high altitude, does not need a mast and ground, doesn't require expensive copper, does not allow easy surface access to line tapping thieves who wish to steal the electric energy. And this levitating electric line may be suspended with equal ease over sea as over land.

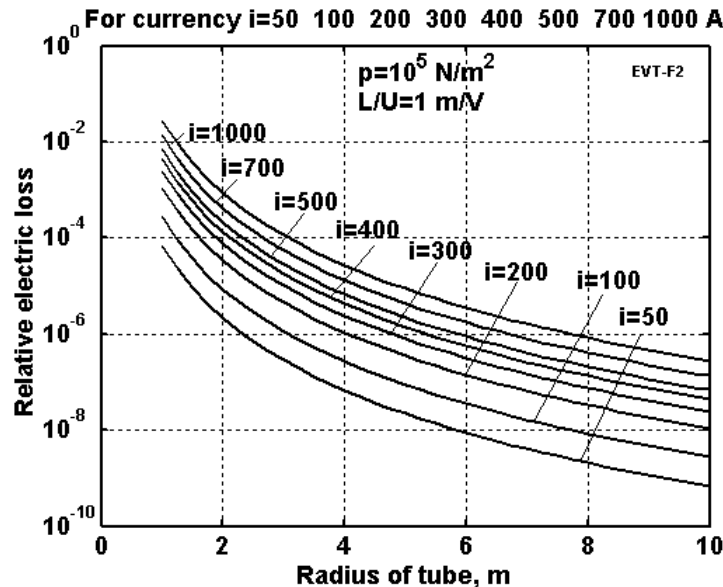
**6. Lift force of tube** ( $L_{F,1}$ , kg/m) and mass of 1 m length of tube ( $W_1$ , kg/m) is

$$L_{F,1} = \rho v = \rho \pi r^2, \quad W_1 = 2\pi r^2 \gamma \delta, \quad (11)$$

where  $\rho$  is air density, at sea level  $\rho = 1.225 \text{ kg}/\text{m}^3$ ;  $v$  is volume of 1 m of tube length,  $\text{m}^3$ ;  $\gamma$  is density of tube envelope, for most plastic  $\gamma = 1500 \div 1800 \text{ kg}/\text{m}^3$ ;  $\delta$  is film thickness, m.

*Example.* For  $r = 10$  m and  $\delta = 0.1$  mm, the lift force is 384 kg/m and cover mass is 11.3 kg/m.

**7. Artificial fiber and tube (cable) properties** [16]-[19]. Cheap artificial fibers are currently being manufactured, which have tensile strengths of 3-5 times more than steel and densities 4-5 times less than steel. There are also experimental fibers (whiskers) that have tensile strengths 30-100 times more than steel and densities 2 to 5 times less than steel. For example, in the book [16] p.158 (1989), there is a fiber (whisker)  $C_D$ , which has a tensile strength of  $\sigma = 8000$  kg/mm<sup>2</sup> and density (specific gravity) of  $\gamma = 3.5$  g/cm<sup>3</sup>. If we use an estimated strength of 3500 kg/mm<sup>2</sup> ( $\sigma = 7 \cdot 10^{10}$  N/m<sup>2</sup>,  $\gamma = 3500$  kg/m<sup>3</sup>), then the ratio is  $\gamma/\sigma = 0.1 \times 10^{-6}$  or  $\sigma/\gamma = 10 \times 10^6$ .



**Fig. 5.** Relative electric loss via radius of tube for electric **current**  $i = 50 \div 1000$  A, the atmospheric pressure into tube and ratio  $L/U = 1$ .

Although the described (1989) graphite fibers are strong ( $\sigma/\gamma = 10 \times 10^6$ ), they are at least still ten times weaker than theory predicts. A steel fiber has a tensile strength of 5000 MPA (500 kg/sq.mm), the theoretical limit is 22,000 MPA (2200 kg/mm<sup>2</sup>) (1987); polyethylene fiber has a tensile strength 20,000 MPA with a theoretical limit of 35,000 MPA (1987). The very high tensile strength is due to its nanotube structure [18].

Apart from unique electronic properties, the mechanical behavior of nanotubes also has provided interest because nanotubes are seen as the ultimate carbon fiber, which can be used as reinforcements in advanced composite technology. Early theoretical work and recent experiments on individual nanotubes (mostly MWNT's, Multi Wall Nano Tubes) have confirmed that nanotubes are one of the stiffest materials ever made. Whereas carbon-carbon covalent bonds are one of the strongest in nature, a structure based on a perfect arrangement of these bonds oriented along the axis of nanotubes would produce an exceedingly strong material. Traditional carbon fibers show high strength and stiffness, but fall far short of the theoretical, in-plane strength of graphite layers by an order of magnitude. Nanotubes come close to being the best fiber that can be made from graphite.

For example, whiskers of Carbon nanotube (CNT) material have a tensile strength of 200 Giga-Pascals and a Young's modulus over 1 Tera Pascals (1999). The theory predicts 1 Tera Pascals and a Young's modulus of 1-5 Tera Pascals. The hollow structure of nanotubes makes them very light (the specific density varies from 0.8 g/cc for SWNT's (Single Wall Nano Tubes) up to 1.8 g/cc for MWNT's, compared to 2.26 g/cc for graphite or 7.8 g/cc for steel). Tensile strength of MWNT's nanotubes reaches 150 GPa.

In 2000, a multi-walled carbon nanotube was tested to have a tensile strength of 63 GPa. Since carbon nanotubes have a low density for a solid of 1.3-1.4 g/cm<sup>3</sup>, its [specific strength](#) of up to 48,000 kN·m/kg is the best of known materials, compared to high-carbon steel's 154 kN·m/kg.

The theory predicts the tensile stress of different types of nanotubes as: Armchair SWNT - 120 GPa, Zigzag SWNT – 94 GPa.

Specific strength (strength/density) is important in the design of the systems presented in this paper; nanotubes have values at least 2 orders of magnitude greater than steel. Traditional carbon fibers have a specific strength 40 times that of steel. Since nanotubes are made of graphitic carbon, they have good resistance to chemical attack and have high thermal stability. Oxidation studies have shown that the onset of oxidation shifts by about 100<sup>0</sup> C or higher in nanotubes compared to high modulus graphite fibers. In a vacuum, or reducing atmosphere, nanotube structures will be stable to any practical service temperature (in vacuum up 2800 °C. in air up 750°C).

In theory, metallic nanotubes can have an electric current density (along axis) more than 1,000 times greater than metals such as silver and copper. Nanotubes have excellent heat conductivity along axis up 6000 W/mK. Copper, by contrast, has only 385 W/mK.

About 60 tons/year of nanotubes are produced now (2007). Price is about \$100 - 50,000/kg. Experts predict production of nanotubes on the order of 6000 tons/year and with a price of \$1 – 100/kg to 2012.

Commercial artificial fibers are cheap and widely used in tires and countless other applications. The authors have found only older information about textile fiber for inflatable structures (Harris J.T., Advanced Material and Assembly Methods for Inflatable Structures, AIAA, Paper No. 73-448, 1973). This refers to DuPont textile Fiber **B** and Fiber **PRD-49** for tire cord. They are 6 times strong as steel (psi is 400,000 or 312 kg/mm<sup>2</sup>) with a specific gravity of only 1.5. Minimum available yarn size (denier) is 200, tensile module is 8.8×10<sup>6</sup> (**B**) and 20×10<sup>6</sup> (**PRD-49**), and ultimate elongation (percent) is 4 (**B**) and 1.9 (**PRD-49**). Some data are in Table 1.

**Table 1.** Material properties

Material	Tensile strength kg/mm <sup>2</sup>	Density g/cm <sup>3</sup>	Fibers	Tensile strength kg/mm <sup>2</sup>	Density g/cm <sup>3</sup>
Whiskers					
AlB <sub>12</sub>	2650	2.6	QC-8805	620	1.95
B	2500	2.3	TM9	600	1.79
B <sub>4</sub> C	2800	2.5	Allien 1	580	1.56
TiB <sub>2</sub>	3370	4.5	Allien 2	300	0.97
SiC	1380-4140	3.22	Kevlar or Twaron	362	1.44
<b>Material</b>			Dynecta or Spectra	230-350	0.97
Steel prestressing strands	186	7.8	Vectran	283-334	0.97
Steel Piano wire	220-248		E-Glass	347	2.57
Steel A514	76	7.8	S-Glass	471	2.48
Aluminum alloy	45.5	2.7	Basalt fiber	484	2.7
Titanium alloy	90	4.51	Carbon fiber	565	1,75
Polypropylene	2-8	0.91	Carbon nanotubes	6200	1.34

Source: [16]-[19] and Howatson A.N., Engineering Tables and Data, p.41.

Industrial fibers have up to  $\sigma = 500 - 600 \text{ kg/mm}^2$ ,  $\gamma = 1500 - 1800 \text{ kg/m}^3$ , and  $\sigma/\gamma = 2,78 \times 10^6$ . But we are projecting use in the present projects the cheapest films and cables applicable (safety  $\sigma = 100 - 200 \text{ kg/mm}^2$ ).

**8. Dielectric strength of insulator.** As you see above, the tube needs film that separates the positive charges located in conductive layer from the electron gas located in the tube. This film must have a high dielectric strength. The current material can keep a high  $E$  (see table 2 is taken from [10]).

**Table 2.** Properties of various good insulators (recalculated in metric system)

Insulator	Resistivity Ohm-m.	Dielectric strength MV/m. $E_i$	Dielectric constant, $\epsilon$
Lexan	$10^{17}$ – $10^{19}$	320–640	3
Kapton H	$10^{19}$ – $10^{20}$	120–320	3
Kel-F	$10^{17}$ – $10^{19}$	80–240	2–3
Mylar	$10^{15}$ – $10^{16}$	160–640	3
Parylene	$10^{17}$ – $10^{20}$	240–400	2–3
Polyethylene	$10^{18}$ – $5 \times 10^{18}$	40–680*	2
Poly (tetra- fluoroethylene)	$10^{15}$ – $5 \times 10^{19}$	40–280**	2
Air (1 atm, 1 mm gap)		4	1
Vacuum ( $1.3 \times 10^{-3}$ Pa, 1 mm gap)		80–120	1

\*For room temperature 500 – 700 MV/m.

\*\* 400–500 MV/m.

Sources: Encyclopedia of Science & Technology (New York, 2002, Vol. 6, p. 104, p. 229, p. 231) and Kikoin [17] p. 321.

Note: Dielectric constant  $\epsilon$  can reach 4.5 - 7.5 for mica ( $E$  is up 200 MV/m), 6 -10 for glasses ( $E = 40$  MV/m), and 900 - 3000 for special ceramics (marks are CM-1, T-900) [17], p. 321, ( $E = 13$  -28 MV/m). Ferroelectrics have  $\epsilon$  up to  $10^4$  -  $10^5$ . Dielectric strength appreciably depends from surface roughness, thickness, purity, temperature and other conditions of materials. Very clean material without admixture (for example, quartz) can have electric strength up 1000 MV/m. As you see, we have the needed dielectric material, but it is necessary to find good (and strong) isolative materials and to research conditions which increase the dielectric strength.

**9. Tube cover thickness.** The thickness of the tube's cover may be found from Equation

$$\delta = \frac{rP}{\sigma}, \quad (12)$$

where  $p$  is electron pressure minus atmospheric pressure, N/m<sup>2</sup>. If electron pressure is little more then the atmospheric pressure the tube cover thickness may be very thin.

**10. Mass of tube cover.** The mass of tube cover is

$$M_1 = \delta\gamma, \quad M = 2\pi rL\gamma\delta, \quad (13)$$

where  $M_1$  is 1 m<sup>2</sup> cover mass, kg/m<sup>2</sup>;  $M$  is cover mass, kg.

**11. The volume  $V$  and surface of tube  $s$  are**

$$V = \pi r^2 L, \quad s = 2\pi rL, \quad (14)$$

where  $V$  is tube volume, m<sup>3</sup>;  $s$  is tube surface, m<sup>2</sup>.

**12. Relation between tube volume charge and tube liner charge** for neutral tube is

$$E_V = \frac{\rho r}{2\epsilon_0}, \quad E_s = \frac{\tau}{2\pi\epsilon_0 r}, \quad E_V = E_s, \quad \tau = \pi\rho r^2, \quad \rho = \frac{\tau}{\pi r^2}, \quad (15)$$

where  $\rho$  is tube volume charge, C/m<sup>3</sup>;  $\tau$  is tube linear charge, C/m.

**13. General charge of tube.** We got equation from

$$\tau = 2\pi\epsilon\epsilon_0 Er, \quad Q = \tau L, \quad Q = 2\pi\epsilon\epsilon_0 ErL, \quad (16)$$

where  $Q$  is total tube charge, C;  $\epsilon$  is dielectric constant (see Table 2).

**14. Charging energy.** The charged energy is computed by equation

$$W = 0.5QU, \quad U = \delta E, \quad W = 0.5Q\delta E, \quad (17)$$

where  $W$  is charge energy, J;  $U$  is voltage, V.

**15. Mass of electron gas.** The mass of electron gas is

$$M_e = m_e N = m_e \frac{Q}{e}, \quad (18)$$

where  $M_e$  is mass of electron gas, kg;  $m_e = 9.11 \times 10^{-31}$  kg is mass of electron;  $N$  is number of electrons,  $e = 1.6 \times 10^{-19}$  is the electron charge, C.

**16. Transfer of matter** (Matter flow of ion gas). If we change the electron gas by the ion gas, our tube transfer charged matter with very high speed

$$M = M_i \pi r^2 V, \quad M_i = \mu m_p n, \quad (19)$$

$$V = \frac{i}{en\pi r^2}, \quad M = \frac{m_p}{e} \mu i = 1.04 \cdot 10^{-8} \mu i,$$

where  $M$  is the mass flow, kg/s;  $M_i$  is the gas ion density, kg/m<sup>3</sup>;  $\mu = m_i/m_p$ ;  $V$  is ions speed, m/s.

*Example:* We want to transfer to a remote location the nuclear breeder fuel – Uranium-238. ( $\mu = 238$ ) by line having  $i = 1000$  A,  $r = 1$  m, ion gas pressure 1 atm. One day contains 86400 seconds.

The equation (19) gives  $M = 214$  kg/day, speed  $V = 120$  km/s. The AB-tubes are suitable for transferring small amounts of a given matter. For transferring a large mass the diameter of tube and electric current must be larger.

We must also have efficient devices for ionization and utilization of the de-ionization (recombination) energy.

The offered method allows direct conversion of the ionization energy of the electron gas or ion gas to light (for example, by connection between the electron and ion gases).

**17. Electron gas pressure.** The electron gas pressure may be computed by equation (11). This computation is presented in fig. 6.

As you see the electron pressure reaches 1 atm for an electric intensity 150 MV/m and for negligibly small mass of the electron gas.

**18. Power for support of charge.** Leakage current (power) through the cover may be estimated by equation

$$I = \frac{U}{R}, \quad U = \delta E = \frac{r\epsilon_0 E}{\sigma}, \quad R = \rho \frac{\delta}{s}, \quad I = \frac{sE}{\rho}, \quad W_l = IU = \frac{\delta s E^2}{\rho}, \quad (20)$$

where  $I$  is electric current, A;  $U$  is voltage, V;  $R$  is electric resistance, Ohm;  $\rho$  is specific resistance, Ohm·m;  $s$  is tube surface area, m<sup>2</sup>.

The estimation gives the support power has small value.

The proposed AB-Tube may become what we may term ‘quasi-superconductive’ when magnetic pressure equals electrostatic pressure. In this case electrons cannot contact with the tube wall, do not experience resistance friction and the AB-Tube thus experiences this ‘quasi-superconductivity’.

Let us to get this condition:

$$P_e = \frac{\epsilon_0 E^2}{2}, \quad P_m = \frac{B^2}{2\mu_0}, \quad P_e = P_m, \quad c = \frac{1}{\sqrt{\mu_0 \epsilon_0}}, \quad E = cB, \quad (21)$$

where  $P_e$  is electronic pressure, N/m<sup>2</sup>;  $P_m$  is magnetic pressure, N/m<sup>2</sup>;  $B$  is magnetic intensity, T;  $E$  is electric intensity, V/m;  $c$  is light speed,  $c = 3 \times 10^8$  m/s;  $\epsilon_0, \mu_0 = 4\pi \times 10^{-7}$  are electrostatic and magnetic constants. The relation  $E = cB$  is important result and condition of tube superconductivity. For electron pressure into tube 1 atm, the  $E = 1.5 \times 10^8$  V/m (see above) and  $B = 0.5$  T.



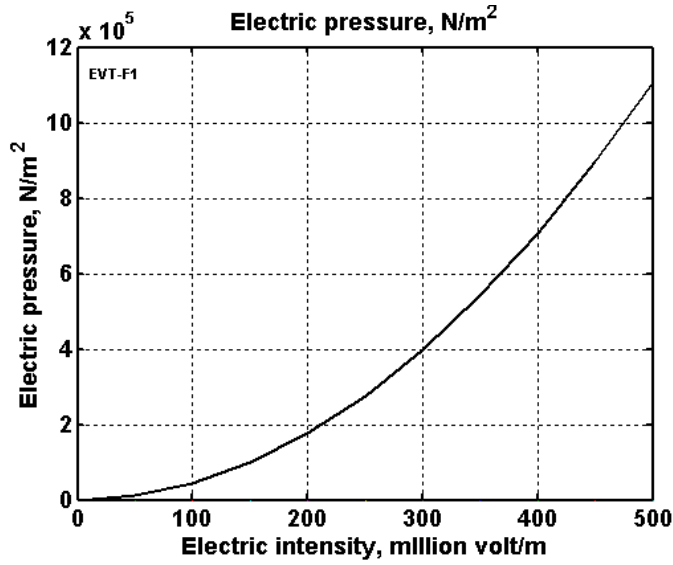


Fig. 6. Electron pressure versus electric intensity

### Quasi-superconductivity of AB-Tube.

From Eq. (21) we receive the relation between the electric current and the tube charge for AB-Tube ‘quasi-superconductivity’ as

$$E = cB, \quad E = \frac{1}{2\pi\epsilon_0} \frac{\tau}{r}, \quad B = \frac{\mu_0 i}{2\pi r}, \quad i = c\tau, \quad (22)$$

where  $i$  is electric current, A;  $\tau$  is liner charge of tube, C/m.

For electron pressure equals 1 atm and  $r = 1$  m the linear tube charge is  $\tau = 0.00833$  C/m (see above) and the request electric current is  $i = 2.5 \times 10^6$  A ( $j = 0.8$  A/m<sup>2</sup>). For  $r = 0.1$  m the current equals  $i = 2.5 \times 10^5$  A. And for  $r = 0.01$  m the current equals  $i = 2.5 \times 10^4$  A.

Unfortunately, the requested electron speed (for true and full normal temperature ‘superconductivity’) equals light speed  $c$ .

$$V = \frac{j}{en} = \frac{i}{en\pi r^2} = \frac{c\tau}{en\pi r^2} = \frac{c\tau}{\tau} = c, \quad (23)$$

That means we cannot exactly reach it, but we can come very close and we can have very low electric resistance of AB-Tube.

**Information about high speed of electron and ion beam.** Here  $\gamma = (1 - \beta^2)^{-1/2}$  is the relativistic scaling factor,  $\beta = v/c$ ,  $v$  is relative system speed; quantities in analytic formulas are expressed in SI or cgs units, as indicated; in numerical formulas  $I$  is in amperes (A),  $B$  is in gauss (G, 1 T = 10<sup>4</sup> G), electron linear density  $N$  is in cm<sup>-1</sup>, temperature, voltage, and energy are in MeV,  $\beta_z = v_z/c$ , and  $k$  is Boltzmann’s constant.

If the system is moved only along axis  $x$ , the Lorentz transformation are (“’” is marked mobile system):

$$t' = \gamma \left( t - \frac{vx}{c^2} \right), \quad x' = \gamma(x - vt), \quad y' = y, \quad z' = z, \quad (24)$$

$$w' = \frac{w - v}{1 - vw/c^2}, \quad M = \gamma m, \quad \vec{p} = M\vec{v}, \quad \vec{f} = \frac{d\vec{p}}{dt},$$

where  $t$  is time, s;  $w$  is speed into systems, m/s,  $v$  is system speed, m/s,  $M$  is relativistic mass, kg;  $p$  is momentum,  $f$  is force, N.

For computation electrostatic and magnetic fields about light speed are useful the equations of relativistic theory (Lorenz's Equations, In the immobile system (market "1")) the electric field is directed along axis  $y$ , the magnetic field is directed along axis  $z$ ):

$$\begin{aligned} E_x &= E_{1x}, & H_x &= H_{1x}, \\ \sqrt{1-\beta^2} E_y &= E_{1y} - vB_{1z}, & \sqrt{1-\beta^2} H_y &= H_{1y} + vD_{1z}, \\ \sqrt{1-\beta^2} E_z &= E_{1z} + vB_{1y}, & \sqrt{1-\beta^2} H_z &= H_{1z} - vD_{1y}, \end{aligned} \quad (25)$$

where lower index "1" means the immobile system coordinate,  $E$  is electric intensity, V/m;  $H$  is magnetic intensity, A/m;  $v$  is speed of mobile system coordinate along axis  $x$ , m/s;  $D$  is electric displacement. C/m<sup>2</sup>;  $\beta = v/c$  is relative speed one system about the other.

Relativistic electron gyroradius [22]:

$$r_e = \frac{mc^2}{eB} (\gamma^2 - 1)^{1/2} \quad (\text{cgs}) = 1.70 \cdot 10^3 (\gamma^2 - 1)^{1/2} B^{-1} \quad \text{cm}. \quad (26)$$

Relativistic electron energy:

$$W = mc^2 \gamma = 0.511 \gamma \quad \text{MeV}. \quad (27)$$

Bennett pinch condition:

$$I^2 = 2Nk(T_e + T_i)c^2 \quad (\text{cgs}) = 3.20 \cdot 10^{-4} N(T_e + T_i) \quad \text{A}^2. \quad (28)$$

Alfvén-Lawson limit:

$$I_A = (mc^3/e)\beta_z \gamma \quad (\text{cgs}) = (4\pi mc / \mu_0 e)\beta_z \gamma \quad (\text{SI}) = 1.70 \cdot 10^4 \beta_z \gamma \quad \text{A}. \quad (29)$$

The ratio of net current to  $I_A$  is

$$\frac{I}{I_A} = \frac{v}{\gamma}. \quad (30)$$

Here  $v = Nr_e$  is the Budker number, where  $r_e = e^2/mc^2 = 2.82 \cdot 10^{-13}$  cm is the classical electron radius. Beam electron number density is

$$n_b = 2.08 \cdot 10^8 J \beta^{-1} \quad \text{cm}^{-3}, \quad (31)$$

where  $J$  is the current density in A cm<sup>-2</sup>. For a uniform beam of radius  $a$  (in cm):

$$n_b = 6.63 \cdot 10^7 I a^{-2} \beta^{-1} \quad \text{cm}^{-3} \quad (32)$$

and

$$\frac{2r_e}{a} = \frac{v}{\gamma}, \quad (33)$$

Child's law: nonrelativistic space-charge-limited current density between parallel plates with voltage drop  $V$  (in MV) and separation  $d$  (in cm) is

$$J = 2.34 \cdot 10^3 V^{3/2} d^{-2} \quad \text{A cm}^{-2} \quad (34)$$

The condition for a longitudinal magnetic field  $B_z$  to suppress filamentation in a beam of current density  $J$  (in A cm<sup>-2</sup>) is

$$B_z > 47 \beta_z (\gamma J)^{1/2} \quad \text{G}. \quad (35)$$

Kinetic energy necessary to accelerate a particle is

$$K = (\gamma - 1)mc^2. \quad (36)$$

The de Broglie wavelength of particle is  $\lambda = h/p$ , where  $h = 6.6262 \times 10^{-34}$  J·s is Planck constant,  $p$  is particle momentum. Classical radius of electron is  $2.8179 \times 10^{-15}$  m.

## Macroprojects

**Wireless transferring energy between Earth's continents** (Fig. 2). Let us take the following initial data: Gas pressure at altitude 100 km is  $p = 3.2 \times 10^{-3} \text{ N/m}^2$ , temperature is 209 K, diameter nitrogen  $\text{N}_2$  molecule is  $3.7 \times 10^{-10} \text{ m}$ , the ion/electron density in ionosphere is  $n = 10^{10} \text{ 1/m}^3$ , radius of the conductivity inflatable balloon at top the space tower (mast) is  $a = 100 \text{ m}$  (contact area is  $S = 1.3 \times 10^5 \text{ m}^2$ ), specific electric resistance of a sea water is  $0.3 \text{ } \Omega \cdot \text{m}$ , area of the contact sea plate is  $1.3 \times 10^3 \text{ m}^2$ .

The computation used equation (1)-(2) and (15)-(17) [4] gives: electron track in ionosphere is  $L = 1.5 \text{ m}$ , electron velocity  $v = 9 \times 10^4 \text{ m/s}$ , track time  $\tau = 1.67 \times 10^{-5} \text{ s}$ , specific resistance of ionosphere is  $\rho = 4.68 \times 10^{-3} \text{ (}\Omega \cdot \text{m)}^{-1}$ , contact resistance of top ball (balloon) is  $R_1 = 0.34 \text{ } \Omega$ , contact resistance of the lower sea plates is  $R_2 = 4.8 \times 10^{-3} \text{ } \Omega$ , electric intensity on ball surface is  $5 \times 10^4 \text{ V/m}$ .

If the voltage is  $U = 10^7 \text{ V}$ , total resistance of electric system is  $R = 100 \text{ } \Omega$ , then electric current is  $I = 10^5 \text{ A}$ , transferring power is  $W = IU = 10^{12} \text{ W}$ , coefficient efficiency is 99.66%. That is power 1000 powerful electric plants, having power one billion watts. In practice we are not limited in transferring any energy in any Earth's point having the 100 km space mast and further transfer by ground-based electric lines in any geographical region of radius  $1000 \div 2000 \text{ km}$ .

**Earth's ionosphere as the storage electric energy.** It is using the equations (18)-(19) [4] we find the Earth's-ionosphere capacity  $C = 4.5 \times 10^{-2} \text{ C}$ . If  $U = 10^8 \text{ V}$ , the storage energy is  $E = 0.5CU^2 = 2.25 \times 10^{14} \text{ J}$ . That is large energy. About 20 of 100 tons rocket may be launched to space in 100 km orbit. This energy are produced a powerful electric plant in one day.

Let us now estimate the leakage of current. Cosmic rays and Earth's radioactivity create  $1.5 \div 10.4$  ions every second in  $1 \text{ cm}^3$ . But they quickly recombine in neutral molecule and the ions concentration is small. We take the ion concentration of lower atmosphere  $n = 10^6 \text{ 1/m}^3$ . Then the specific conductivity of Earth's atmosphere is  $2.1 \times 10^{-17} \text{ (}\Omega \cdot \text{m)}^{-1}$ . The leakage current is  $i = 10^{-7} \times U$ . The altitude of E-layer is 100 km. We take a thickness of atmosphere only 10 km. Then the conductivity of Earth's atmosphere is  $10^{-24} \text{ (}\Omega \cdot \text{m)}^{-1}$ , resistance is  $R_a = 10^{24} \text{ } \Omega$ , the leakage time (decreasing of energy in  $e = 2.73$  times) is  $1.5 \times 10^5$  years.

As you can clearly see the Earth's ionosphere may become a gigantic storage site of electricity.

The electric resistance of electronic tube is small.

## Discussing

The offered ideas and innovations may create a jump in space and energy industries. Author has made initial base researches that conclusively show the big industrial possibilities offered by the methods and installations proposed.

The offered inflatable electrostatic AB tube has indisputably remarkable operational advantages in comparison with the conventional electric lines. AB-tube may be also used for transfer electricity in long distance without using ionosphere.

The main innovations and applications of AB-Tubes are:

1. Transferring electric energy in a long distance (up 10,000 km) with a small electric loss.
2. 'Quasi-superconductivity'. The offered AB-Tube may have a very low electric resistance for any temperature because the electrons in the tube do not have ions and do not lose energy by impacts with ions. The impact the electron to electron does not change the total impulse (momentum) of couple electrons and electron flow. If this idea is proved in experiment, that will be big breakthrough in many fields of technology.

3. Cheap electric lines suspended in high altitude (because the AB-Tube can have lift force in atmosphere and do not need ground mounted electric masts and other support structures)
4. The big diameter AB-Tubes (including the electric lines for internal power can be used as tramway for transportation .
5. AB-Tubes can be used as vacuum tubes for an exit from the Earth's surface to outer space (out from Earth's atmosphere). That may be used by an Earth telescope for observation of sky without atmosphere hindrances, or sending of a plasma beam to space ships without atmosphere hindrances [12-14].
6. Transfer of electric energy from continent to continent through the Earth's ionosphere [4-5].
7. Inserting an anti-gravitator cable into a vacuum-enclosing AB-Tube for near-complete elimination of air friction [4-5]. Same application for transmission of mechanical energy for long distances with minimum friction and losses. [4-5].
8. Increasing in some times the range of a conventional gun. They can shoot through the vacuum tube (up 4-6 km) and projectile will fly in the rare atmosphere where air drag is small.
9. Transfer of matter a long distance with high speed (including in outer space, see other of author's works).
10. Interesting uses in nuclear and high energy physics engineering (inventions).

The offered electronic gas may be used as filling gas for air balloons, dirigibles, energy storage, submarines, electricity-charge devices (see also [4]-[15]).

Further research and testing are necessary. As that is in science, the obstacles can slow, even stop, applications of these revolutionary innovations.

### Summary

This new revolutionary idea - wireless transferring of electric energy in long distance through the ionosphere or by the electronic tubes is offered and researched. A rare plasma power cord as electric cable (wire) is used for it. It is shown that a certain minimal electric current creates a compressed force that supports the plasma cable in the compacted form. Large amounts of energy can be transferred many thousands of kilometers by this method. The requisite mass of plasma cable is merely hundreds of grams. It is computed that the macroproject: The transfer of colossal energy from one continent to another continent (for example, Europe to USA and back), using the Earth's ionosphere as a gigantic storage of electric energy.

### References

(Reader finds some of author's articles in <http://Bolonkin.narod.ru/p65.htm> and <http://arxiv.org> , search "Bolonkin", in books "*Non-Rocket Space Launch and Flight*", Elsevier, 2006, 488 pgs.; "*New concepts, Ideas, and Innovation in Aerospace, Technology and Human Science*", NOVA, 2007, 502 pgs.; *Macro-Projects: Environment and Technology*, NOVA, 2008, 536 pgs.).

1. Bolonkin, A.A., (1982), Installation for Open Electrostatic Field, Russian patent application #3467270/21 116676, 9 July, 1982 (in Russian), Russian PTO.
2. Bolonkin, A.A., (1983), Method of stretching of thin film. Russian patent application #3646689/10 138085, 28 September 1983 (in Russian), Russian PTO.
3. Bolonkin, A.A., Getting of Electric Energy from Space and Installation for It, Russian patent application #3638699/25 126303, 19 August, 1983 (in Russian), Russian PTO.
4. Bolonkin A.A., Wireless Transfer of Electricity in Outer Space. Presented to <http://Arxiv.org> on 4 January, 2007. Presented as paper AIAA-2007-0590 to 45th AIAA Aerospace Science Meeting, 8 - 11 January 2007, Reno, Nevada, USA.
5. Bolonkin A.A., AB Electronic Tubes and Quasi-Superconductivity at Room Temperature. Presented to <http://arxiv.org> on 8 April, 2008.

6. Bolonkin A.A., Optimal Electrostatic Space Tower , Presented as paper AIAA-2007-6201 to Space-2007 Conference, 18-20 September 2007, Long Beach, CA, USA. <http://arxiv.org> , search "Bolonkin"
7. Bolonkin A.A., Optimal Solid Space Tower, AIAA-2006-7717. ATIO Conference, 25-27 Sept. 2006, Wichita, Kansas, USA. <http://arxiv.org> .
8. Bolonkin A.A., Optimal Inflatable Space Tower with 3-100 km Height, Journal of the British Interplanetary Society, Vol.56, No. 3/4, 2003, pp.97-107.
9. Bolonkin A.A., Kinetic Space Towers. Presented as paper IAC-02-IAA.1.3.03 at World Space Congress-2002 10-19 October, Houston, TX, USA. Detail Manuscript was published as A.A.Bolonkin. "Kunetif Space Towers and Launchers", Journal of the British Interplanetary Society, Vol.57, No.1/2, 2004. pp.33-39.
10. Bolonkin A.A. Linear Electrostatic Engine, The work was presented as paper AIAA-2006-5229 for 42 Joint Propulsion Conference, Sacramento, USA, 9-12 July, 2005. Work is published in International journal AEAT, Vol.78, #6, 2006, pp.502-508.
11. Bolonkin A.A., Krinker M., Magnetic Space Launcher, 45 Joint Propulsion Conference, USA, 2009.
12. Bolonkin A.A., *Non-Rocket Space Launch and Flight*, Elsevier, London, 2006, 488 pgs.
13. Bolonkin A.A., "*New concepts, Ideas, and Innovation in Aerospace, Technology and Human Science*", NOVA, 2008, 502 pgs.
14. Bolonkin A.A., Cathcart R.B., "*Macro-Projects: Environment and Technology*", NOVA, 2009, 500 pgs.
15. *Macro-Engineering - A challenge for the future*. Collection of articles. Eds. V. Badescu, R. Cathcart and R. Schuiling, Springer, 2006. See article: "Space Towers" by A.Bolonkin.
16. Galasso F.S., *Advanced Fibers and Composite*, Gordon and Branch Science Publisher, 1989.
17. Kikoin, I.K., (ed.), *Tables of physical values*. Atomuzdat, Moscow, 1976 (in Russian).
18. Dresselhaus M.S., *Carbon Nanotubes*, Springer, 2000.
19. AIP. *Physics desk reference*, 3-rd Edition, Springer, 2003.
20. Wikipedia.

Special aircraft



## Chapter 6

# Transparent Inflatable Blanket for Cities

(for continual pleasant weather and protection from chemical , biological and radioactive weapons)

### Abstract

In a series of previous articles (see references) the author offered to cover a city or other important large installations or subregions by a transparent thin film supported by a small additional air overpressure under the form of an AB Dome. That allows keeping the outside atmospheric conditions (for example weather) away from the interior of the inflatable Dome, protecting a city by its' presence from chemical, bacterial, and radioactive weapons and even partially from aviation and nuclear bombs.

The building of a gigantic inflatable AB Dome over an empty flat surface is not difficult. The cover is spread on a flat surface and a ventilator pumps air under the film cover and lifts the new dome into place (inflation takes many hours). However, if we want to cover a city, garden, forest or other obstacle course (as opposed to an empty, mowed field) we cannot easily deploy the thin film over building or trees without risking damage to it by snagging and other complications. In this article is suggested a new method which solves this problem. The idea is to design a double film blanket filled by light gas (for example, methane, hydrogen, or helium - although of these, methane will be the most practical and least leaky). Sections of this AB Blanket are lighter than air and fly in atmosphere. They can be made on a flat area (serving as an assembly area) and delivered by dirigible or helicopter to station at altitude over the city. Here they connect to the already assembled AB Blanket subassemblies, cover the city in an AB Dome and protect it from bad weather, chemical, biological and radioactive fallout or particulates. After finish of dome building the light gas can be changed by air.

Two projects for Manhattan (NY, USA) and Moscow (Russia) are targets for a sample computation.

-----  
**Key words:** Dome for city, blanket for city, greenhouse, regional control of weather, protection of cities from chemical, biological and radioactive weapons.

### Introduction

**Idea.** The inflatable transparent thin film AB Dome offered and developed by author in [1-15] is a good means for converting a city or region into a subtropical garden with excellent weather, obtainable clean water from condensation (and avoided evaporation), saved energy for heating houses (in cold regions), reflecting energy for cooling houses (in hot regions), protection of city from chemical, bacterial, radioactive weapons in war time, even the provision of electricity etc.

However, the author did not describe the method – by which we can cover a city, forest or other obstacle-laden region by thin film.

This article suggests a method for covering the city and any surface which is neither flat nor obstruction free by thin film which insulates the city from outer environment, Earth's atmospheric instabilities, cold winter, strong wind, rain, hot weather and so on.

This new subassembly method of building an inflatable dome is named by the author 'AB-Blanket'. This idea is to design from a transparent double film a blanket, with the internal pockets or space filled by light gas (methane, hydrogen, helium). Subassemblies of the AB Blanket are lighter than air and fly in atmosphere. They can be made in a factory, spread on a flat area, filled by gas to float upwards, and delivered by dirigible or helicopter to a sky over the city. Here they are connected to the AB Dome in



building and as additional AB Blankets are brought into place, they cover the city and are sealed together. After finish of dome building the light gas can be changed by air. The film will be supported by small additional air pressure into Dome.



Current rigid structures

**Information about Earth's megacities.** A megacity is usually defined as a metropolitan area with a total population in excess of 10 million people. Some definitions also set a minimum level for population density (at least 2,000 persons/square km). Megacities can be distinguished from global cities by their rapid growth, new forms of spatial density of population, formal and informal economics. A megacity can be a single metropolitan area or two or more metropolitan areas that converge upon one another. The terms *megapolis* and *megalopolis* are sometimes used synonymously with *megacity*.

In 1800 only 3% of the world's population lived in cities. 47% did by the end of the twentieth century. In 1950, there were 83 cities with populations exceeding one million; but by 2007, this had risen to 468 agglomerations of more than one million. If the trend continues, the world's urban population will double every 38 years, say researchers. The UN forecasts that today's urban population of 3.2 billion will rise to nearly 5 billion by 2030, when three out of five people will live in cities.

The increase will be most dramatic in the poorest and least-urbanised continents, Asia and Africa. Surveys and projections indicate that all urban growth over the next 25 years will be in developing countries. One billion people, one-sixth of the world's population, now live in shanty towns,

By 2030, over 2 billion people in the world will be living in slums. Already over 90% of the urban population of Ethiopia, Malawi and Uganda, three of the world's most rural countries, live in slums.

In 2000, there were 18 megacities – conurbations such as Tokyo, New York City, Los Angeles, Mexico City, Buenos Aires, Mumbai (then Bombay), São Paulo, Karachi that have populations in

excess of 10 million inhabitants. Greater Tokyo already has 35 million, which is greater than the entire population of Canada.

By 2025, according to the *Far Eastern Economic Review*, Asia alone will have at least 10 megacities, including Jakarta, Indonesia (24.9 million people), Dhaka, Bangladesh (26 million), Karachi, Pakistan (26.5 million), Shanghai (27 million) and Mumbai (33 million). Lagos, Nigeria has grown from 300,000 in 1950 to an estimated 15 million today, and the Nigerian government estimates that the city will have expanded to 25 million residents by 2015. Chinese experts forecast that Chinese cities will contain 800 million people by 2020.

In 1950, New York was the only urban area with a population of over 10 million. Geographers have identified 25 such areas as of October 2005, as compared with 19 megacities in 2004 and only nine in 1985. This increase has happened as the world's population moves towards the high (75–85%) urbanization levels of North America and Western Europe. The 1990 census marked the first time the majority of US citizens lived in cities with over 1 million inhabitants.

In the 2000s, the largest megacity is the Greater Tokyo Area. The population of this urban agglomeration includes areas such as Yokohama and Kawasaki, and is estimated to be between 35 and 36 million. This variation in estimates can be accounted for by different definitions of what the area encompasses. While the prefectures of Tokyo, Chiba, Kanagawa, and Saitama are commonly included in statistical information, the Japan Statistics Bureau only includes the area within 50 kilometers of the Tokyo Metropolitan Government Offices in Shinjuku, thus arriving at a smaller population estimate. A characteristic issue of megacities is the difficulty in defining their outer limits and accurately estimating the population.



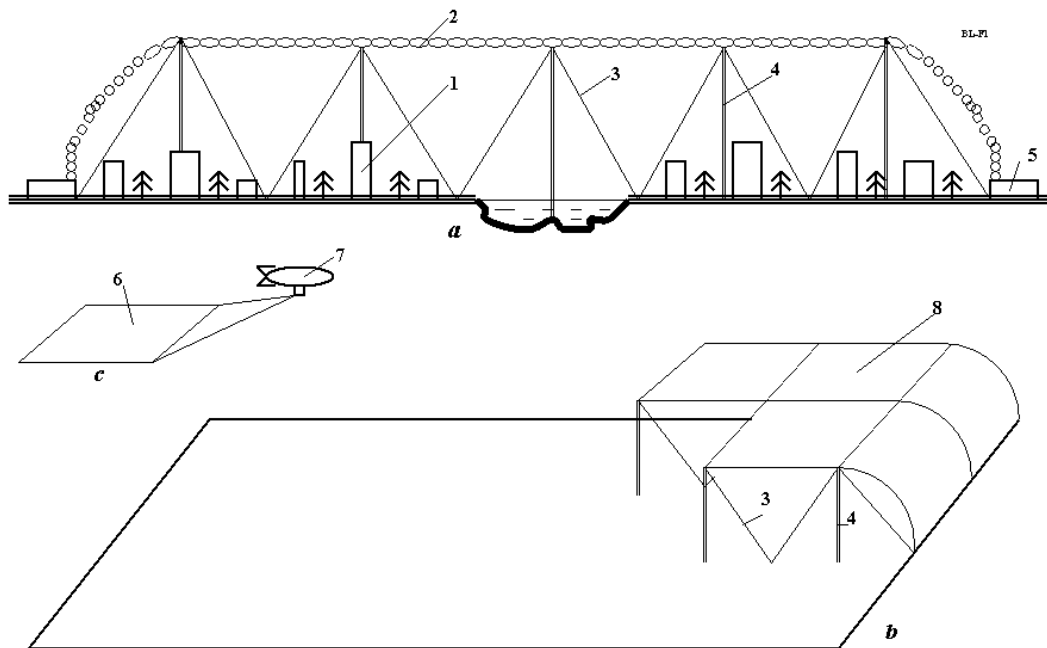
Project of rigid dome over central part of city.

## Description of Innovations

Our design of the dome from levitated AB Blanket sections is presented in Fig.1 that includes the thin inflated film plate parts. The innovations are listed here: (1) the construction is gas-inflatable; (2) each part is fabricated with very thin, transparent film (thickness is 0.05 to 0.2 mm) having controlled clarity (option); (3) the enclosing film has two conductivity layers plus a liquid crystal layer between them which changes its clarity, color and reflectivity under an electric voltage (option); (4) The space between double film is filled a light gas (for example: methane, hydrogen or helium). The air pressure inside the dome is more than the external atmosphere also for protection from outer wind, snow and ice.

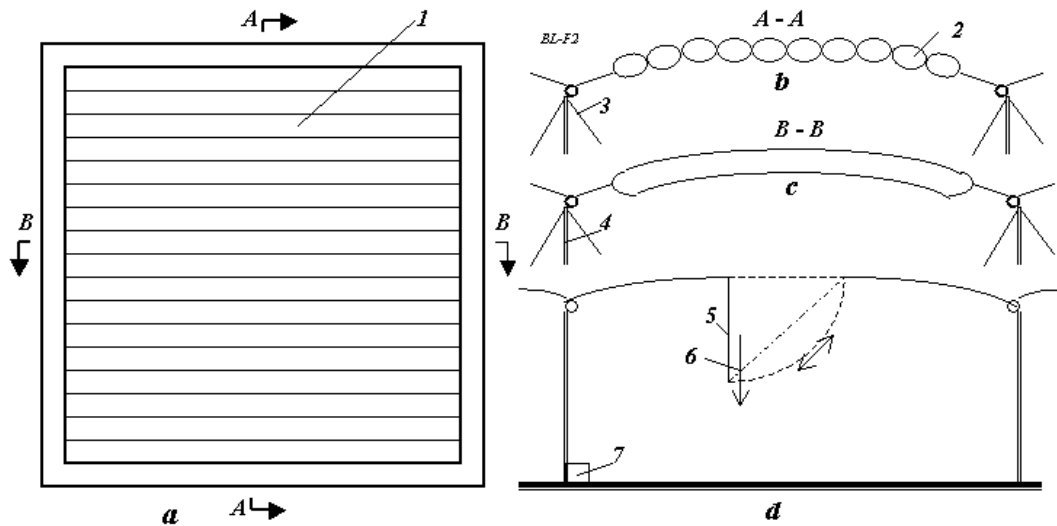
The film (textile) may be conventional (and very cheap) or advanced with realtime controlled clarity for cold and hot regions.

The city AB Dome, constructed by means of these AB Blankets, allows getting clean water from rain for drinking, washing and watering which will often be enough for a city population except in case of extreme density (We shall see this for our calculations in the case of Manhattan, below). This water collected at high altitude (Blanket conventionally located at 100 – 500 m) may produce electric energy by hydro-electric generators located at Earth's surface. Wind generators located at high altitude (at Blanket surface) can produce electric energy. Such an AB Dome saves a lot of energy (fuel) for house heating in winter time and cooling in summer time.



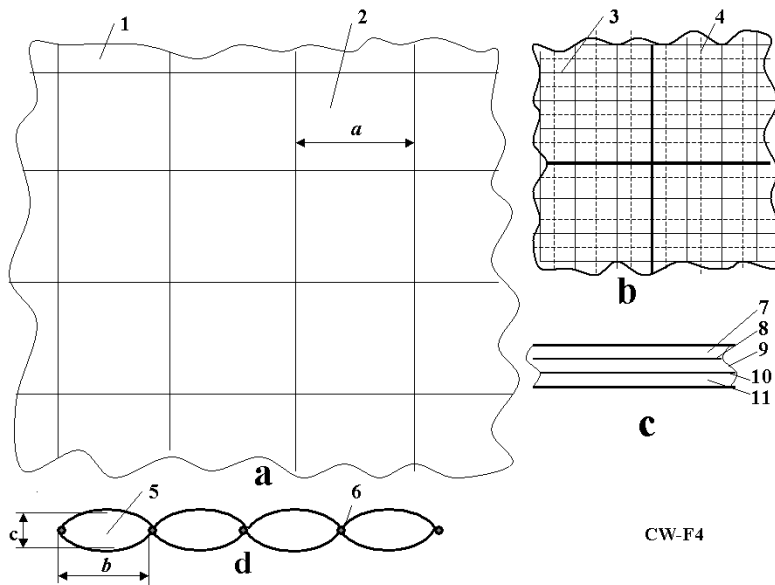
**Fig.1.** (a). Design of AB Blanket from the transparent film over city and (b) building the AB Dome from parts of Blanket. *Notations:* 1 – city; 2 – AB-Blanket; 3 – bracing wire (support cable); 4 – tubes for rain water, for lifting gas, signalization and control; 5 – enter. Exit and ventilator; 6 – part of Blanket; 7 – dirigible; 8 – building the Blanket.

Detail design of Blanket section is shown in fig.2. Every section contains cylindrical tubes filled a light gas, has margins (explained later in Discussion), has windows which can be open and closed (a full section may be window), connected to Earth's surface by water tube, tube for pumping gas, bracing gables and signal and control wires.



**Fig.2.** Design of AB Blanket section. (a) Typical section of Blanket (top view); (b) Cross-section A-A of Blanket; (c) Cross-section B-B of Blanket; (d) Typical section of Blanket (side view). *Notations:* 1 – part of Blanket; 2 – light lift gas (for example: methane, hydrogen or helium); 3 – bracing wire (support cable); 4 – tubes for rain water, for lifting gas, signalization and control; 5 – cover of windows; 6 – snow, ice; 7 – hydro-electric generator, air pump.

Fig. 3 illustrates the advanced thin transparent control Blanket cover we envision. The inflated textile shell—technical “textiles” can be woven or non-woven (films)—embodies the innovations listed: (1) the film is thin, approximately 0.05 to 0.3 mm. A film this thin has never before been used in a major building; (2) the film has two strong nets, with a mesh of about  $0.1 \times 0.1$  m and  $a = 1 \times 1$  m, the threads are about 0.3 - 1 mm for a small mesh and about 1 - 2 mm for a big mesh.



**Fig.3.** Design of advanced covering membrane. *Notations:* (a) Big fragment of cover with controlled clarity (reflectivity, carrying capacity) and heat conductivity; (b) Small fragment of cover; (c) Cross-section of cover (film) having 5 layers; (d) Longitudinal cross-section of cover; 1 - cover; 2 - mesh; 3 - small mesh; 4 - thin electric net; 5 - cell of cover; 6 – margins and wires; 7 - transparent dielectric layer; 8 - conducting

layer (about 1 - 3  $\mu$ ); 9 - liquid crystal layer (about 10 - 100  $\mu$ ); 10 - conducting layer; and 11 - transparent dielectric layer. Common thickness is 0.1 - 0.5 mm. Control voltage is 5 - 10 V.

The net prevents the watertight and airtight film covering from being damaged by vibration; (3) the film incorporates a tiny electrically conductive wire net with a mesh about  $0.1 \times 0.1$  m and a line width of about 100  $\mu$  and a thickness near 10  $\mu$ . The wire net is electric (voltage) control conductor. It can inform the dome maintenance engineers concerning the place and size of film damage (tears, rips, etc.); (4) the film has twin-layered with the gap —  $c = 1-3$  m and  $b = 3-6$  m—between film layers for heat insulation. In polar (and hot) regions this multi-layered covering is the main means for heat isolation and puncture of one of the layers won't cause a loss of shape because the second film layer is unaffected by holing; (5) the airspace in the dome's covering can be partitioned, either hermetically or not; and (6) part of the covering can have a very thin shiny aluminum coating that is about 1  $\mu$  (micron) for reflection of unnecessary solar radiation in equatorial or collect additional solar radiation in the polar regions [2].

The town cover may be used as a screen for projection of pictures, films and advertising on the cover at night time. In the case of Manhattan this alone might pay for it!

**Brif information about advanced cover film.** Our advanced Blanket cover (film) has 5 layers (fig. 3c): transparent dielectric layer, conducting layer (about 1 - 3  $\mu$ ), liquid crystal layer (about 10 - 100  $\mu$ ), conducting layer (for example,  $\text{SnO}_2$ ), and transparent dielectric layer. Common thickness is 0.3 - 1 mm. Control voltage is 5 - 10 V. This film may be produced by industry relatively cheaply.

**1. Liquid crystals (LC)** are substances that exhibit a phase of matter that has properties between those of a conventional liquid, and those of a solid crystal.

Liquid crystals find wide use in liquid crystal displays (LCD), which rely on the optical properties of certain liquid crystalline molecules in the presence or absence of an electric field. The electric field can be used to make a pixel switch between clear or dark on command. Color LCD systems use the same technique, with color filters used to generate red, green, and blue pixels. Similar principles can be used to make other liquid crystal based optical devices. Liquid crystal in fluid form is used to detect electrically generated hot spots for failure analysis in the semiconductor industry. Liquid crystal memory units with extensive capacity were used in Space Shuttle navigation equipment. It is also worth noting that many common fluids are in fact liquid crystals. Soap, for instance, is a liquid crystal, and forms a variety of LC phases depending on its concentration in water.

The conventional controlled clarity (transparency) film reflects superfluous energy back to space if too much. If film has solar cells it may convert part of the superfluous solar energy into electricity.

**2. Transparency.** In optics, transparency is the material property of allowing light to pass through. Though transparency usually refers to visible light in common usage, it may correctly be used to refer to any type of radiation. Examples of transparent materials are air and some other gases, liquids such as water, most glasses, and plastics such as Perspex and Pyrex. Where the degree of transparency varies according to the wavelength of the light. From electrodynamics it results that only a vacuum is really transparent in the strict meaning, any matter has a certain absorption for electromagnetic waves. There are transparent glass walls that can be made opaque by the application of an electric charge, a technology known as electrochromics. Certain crystals are transparent because there are straight lines through the crystal structure. Light passes unobstructed along these lines. There is a complicated theory "predicting" (calculating) absorption and its spectral dependence of different materials. The optic glass has transperance about 95% of light (visible) radiation. The transparency dipents from thickness and may be very high for thin film.

**3. Electrochromism** is the phenomenon displayed by some chemical species of reversibly changing color when a burst of charge is applied.

One good example of an electrochromic material is polyaniline which can be formed either by the

electrochemical or chemical oxidation of aniline. If an electrode is immersed in hydrochloric acid which contains a small concentration of aniline, then a film of polyaniline can be grown on the electrode. Depending on the redox state, polyaniline can either be pale yellow or dark green/black. Other electrochromic materials that have found technological application include the viologens and polyoxotungstates. Other electrochromic materials include tungsten oxide ( $\text{WO}_3$ ), which is the main chemical used in the production of electrochromic windows or smart windows.

As the color change is persistent and energy need only be applied to effect a change, electrochromic materials are used to control the amount of light and heat allowed to pass through windows ("smart windows"), and has also been applied in the automobile industry to automatically tint rear-view mirrors in various lighting conditions. Viologen is used in conjunction with titanium dioxide ( $\text{TiO}_2$ ) in the creation of small digital displays. It is hoped that these will replace LCDs as the viologen (which is typically dark blue) has a high contrast to the bright color of the titanium white, therefore providing a high visibility of the display.

### 3. THEORY AND COMPUTATIONS OF THE AB BLANKET

**1. Lift force of Blanket.** The specific lift force of Blanket is computed by equation:

$$L = g(q_a - q_g)V, \quad (1)$$

where  $L$  is lift force, N;  $g = 9.81 \text{ m/s}^2$  is gravity;  $q_a = 1.225 \text{ kg/m}^3$  is an air density for standard condition ( $T = 15^\circ\text{C}$ );  $q_g < q_a$  is density of lift light gas. For methane  $q_g = 0.72 \text{ kg/m}^3$ , hydrogen  $q_g = 0.09 \text{ kg/m}^3$ , helium  $q_g = 0.18 \text{ kg/m}^3$ ;  $V$  is volume of Blanket,  $\text{m}^3$ . For example, the section  $100 \times 100 \text{ m}$  of the Blanket filled by methane (the cheapest light gas) having the average thickness 3 m has the lift force  $15 \text{ N/m}^2$  or  $150,000 \text{ N} = 15 \text{ tons}$ .

**2. The weight (mass) of film** may be computed by equation

$$W = \gamma \delta S, \quad (2)$$

where  $W$  is weight of film, kg;  $\gamma$  is specific density of film (usually about  $\gamma = 1500 \div 1800 \text{ kg/m}^3$ );  $\delta$  is thickness, m;  $S$  is area,  $\text{m}^2$ . For example, the double film of thickness  $\delta = 0.05 \text{ mm}$  has weight  $W = 0.15 \text{ kg/m}^2$ . The section  $100 \times 100 \text{ m}$  of the Blanket has weight  $1500 \text{ kg} = 1.5 \text{ tons}$ .

**3. Weight (mass) of support cable** (bracing wire) is computed by equation:

$$W_c = \gamma_c \frac{hLS}{\sigma}, \quad (3)$$

where  $W_c$  is weight of support cable, kg;  $\gamma_c$  is specific density of film (usually about  $\gamma_c = 1800 \text{ kg/m}^3$ );  $\sigma$  is safety density of cable,  $\text{N/m}^2$ . For cable from artificial fiber  $\sigma = 100 \div 150 \text{ kg/mm}^2 = (1 \div 1.5) \times 10^9 \text{ N/m}^2$ . For example, for  $\sigma = 100 \text{ kg/mm}^2$ ,  $h = 500 \text{ m}$ ,  $L = 10 \text{ N/m}^2$ ,  $W_c = 0.009 \text{ kg/m}^2$ . However, if additional air pressure into dome is high, for example, lift force  $L = 1000 \text{ N/m}^2$  (air pressure  $P = 0.01 \text{ atm} - 0.01 \text{ bar}$ ), the cable weight may reach  $0.9 \text{ kg/m}^2$ . That may be requested in a storm weather when outer wind and wind dynamic pressure is high.

As wind flows over and around a fully exposed, nearly completely sealed inflated dome, the weather affecting the external film on the windward side must endure positive air pressures as the wind stagnates. Simultaneously, low air pressure eddies will be present on the leeward side of the dome. In other words, air pressure gradients caused by air density differences on different parts of the sheltering dome's envelope is characterized as the "buoyancy effect". The buoyancy effect will be greatest during the coldest weather when the dome is heated and the temperature difference between its interior and exterior are greatest. In extremely cold climates, such as the Arctic and Antarctica, the buoyancy effect tends to dominate dome pressurization, causing the Blanket to require reliable anchoring.

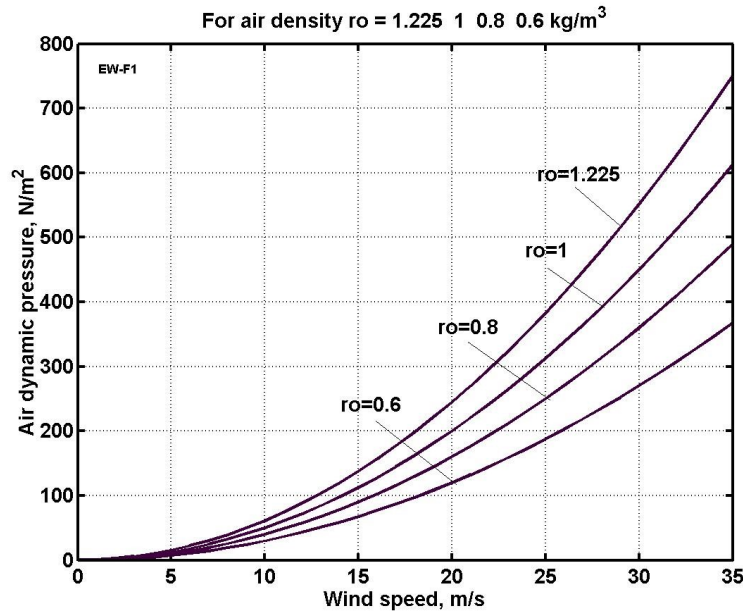
**4. The wind dynamic pressure** is computed by equation



$$p_d = \frac{\rho V^2}{2}, \quad (4)$$

where  $p_d$  is wind dynamic pressure,  $\text{N/m}^2$ ;  $\rho$  is air density, for altitude  $H = 0$  the  $\rho = 1.225 \text{ kg/m}^3$ ;  $V$  is wind speed,  $\text{m/s}$ . The computation is presented in fig.4.

The small overpressure of 0.01 atm forced into the AB-Dome to inflate it produces force  $p = 1000 \text{ N/m}^2$ . That is greater than the dynamic pressure ( $740 \text{ N/m}^2$ ) of very strong wind  $V = 35 \text{ m/s}$  (126  $\text{km/hour}$ ). If it is necessary we can increase the internal pressure by some times if needed for very exceptional storms.



**Fig. 4.** Wind dynamic pressure versus wind speed and air density  $\rho$ . The  $\rho_0 = 0.6$  is for  $H \approx 6 \text{ km}$ .

**5. The thickness of the dome envelope**, its sheltering shell of film, is computed by formulas (from equation for tensile strength):

$$\delta_1 = \frac{Rp}{2\sigma}, \quad \delta_2 = \frac{Rp}{\sigma}, \quad (5)$$

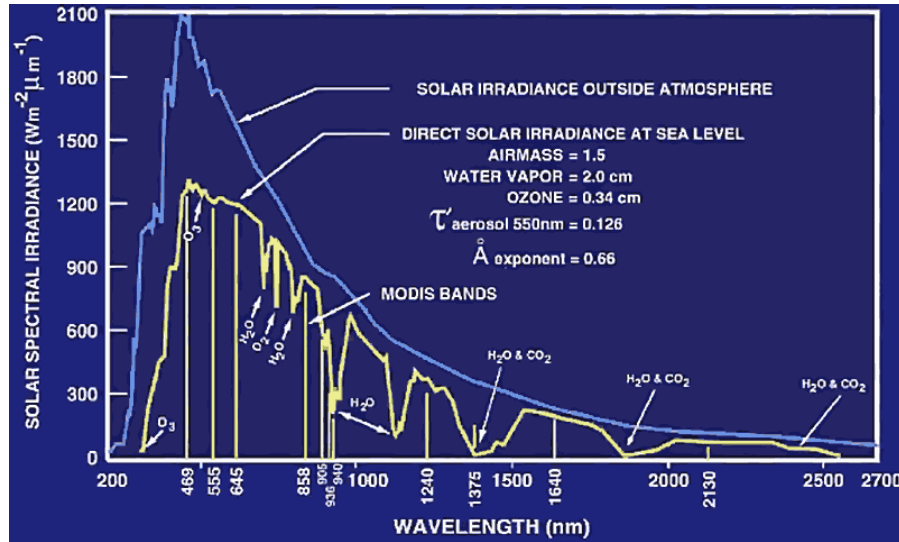
where  $\delta_1$  is the film thickness for a spherical dome,  $\text{m}$ ;  $\delta_2$  is the film thickness for a cylindrical dome,  $\text{m}$ ;  $R$  is radius of dome,  $\text{m}$ ;  $p$  is additional pressure into the dome,  $\text{N/m}^2$ ;  $\sigma$  is safety tensile stress of film,  $\text{N/m}^2$ .

For example, compute the film thickness for dome having radius  $R = 50 \text{ m}$ , additional internal air pressure  $p = 0.01 \text{ atm}$  ( $p = 1000 \text{ N/m}^2$ ), safety tensile stress  $\sigma = 50 \text{ kg/mm}^2$  ( $\sigma = 5 \times 10^8 \text{ N/m}^2$ ), cylindrical dome.

$$\delta = \frac{50 \times 1000}{5 \times 10^8} = 0.0001 \text{ m} = 0.1 \text{ mm} \quad (5)'$$

**6. Solar radiation.** Our basic computed equations, below, are derived from a Russian-language textbook [19]. Solar radiation impinging the orbiting Earth is approximately  $1400 \text{ W/m}^2$ . The average Earth reflection by clouds and the sub-aerial surfaces (water, ice and land) is about 0.3. The Earth-atmosphere adsorbs about 0.2 of the Sun's radiation. That means about  $q_0 = 700 \text{ W/m}^2$ s of solar energy (heat) reaches our planet's surface at the Equator. The solar spectrum is graphed in Fig. 5.





**Fig.5.** Spectrum of solar irradiance outside atmosphere and at sea level with absorption of electromagnetic waves by atmospheric gases. Visible light is  $0.4 - 0.8 \mu$  ( $400 - 800 \text{ nm}$ ).

The visible part of the Sun's spectrum is only  $\lambda = 0.4$  to  $0.8 \mu$ . Any warm body emits radiation. The emission wavelength depends on the body's temperature. The wavelength of the maximum intensity (see Fig. 5) is governed by the black-body law originated by Max Planck (1858-1947):

$$\lambda_m = \frac{2.9}{T}, \quad [mm], \quad (6)$$

where  $T$  is body temperature, °K. For example, if a body has an ideal temperature  $20 \text{ }^\circ\text{C}$  ( $T = 293 \text{ }^\circ\text{K}$ ), the wavelength is  $\lambda_m = 9.9 \mu$ .

The energy emitted by a body may be computed by employment of the Josef Stefan-Ludwig Boltzmann law.

$$E = \varepsilon \sigma_s T^4, \quad [W/m^2], \quad (7)$$

where  $\varepsilon$  is coefficient of body blackness ( $\varepsilon = 0.03 \div 0.99$  for real bodies),  $\sigma_s = 5.67 \times 10^{-8} [W/m^2 \cdot K]$  Stefan-Boltzmann constant. For example, the absolute black-body ( $\varepsilon = 1$ ) emits (at  $T = 293 \text{ }^\circ\text{C}$ ) the energy  $E = 418 \text{ W/m}^2$ .

Amount of the maximum solar heat flow at  $1 \text{ m}^2$  per 1 second of Earth surface is

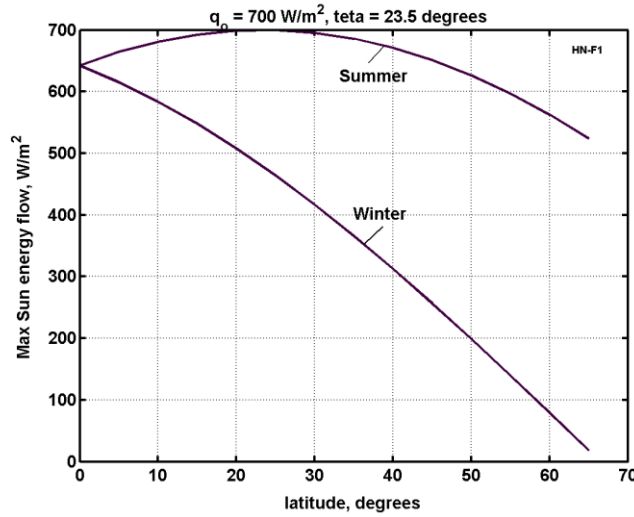
$$q = q_o \cos(\varphi \pm \theta) \quad [W/m^2], \quad (8)$$

where  $\varphi$  is Earth longitude,  $\theta$  is angle between projection of Earth polar axis to the plate which is perpendicular to the ecliptic plate and contains the line Sun-Earth and the perpendicular to ecliptic plate. The sign "+" signifies Summer and the "-" signifies Winter,  $q_o \approx 700 \text{ W/m}^2$  is the annual average solar heat flow to Earth at equator corrected for Earth reflectance.

This angle is changed during a year and may be estimated for the Arctic by the following the first approximation equation:

$$\theta = \theta_m \cos \omega, \quad \text{where} \quad \omega = 2\pi \frac{N}{364}, \quad (9)$$

where  $\theta_m$  is maximum  $\theta$ ,  $|\theta_m| = 23.5^\circ = 0.41 \text{ radian}$ ;  $N$  is number of day in a year. The computations for Summer and Winter are presented in fig.6.



**Fig.6.** Maximum Sun radiation flow at Earth surface as function of Earth latitude and season.

The heat flow for a hemisphere having reflector (fig.1) at noon may be computed by equation

$$q = c_1 q_0 [\cos(\varphi - \theta) + S \sin(\varphi + \theta)], \quad (10)$$

where  $S$  is fraction (relative) area of reflector to service area of "Evergreen" dome. Usually  $S = 0.5$ ;  $c_1$  is film transparency coefficient ( $c_1 \approx 0.9 - 0.95$ ).

The daily average solar irradiation (energy) is calculated by equation

$$Q = 86400 c q t, \quad \text{where } t = 0.5(1 + \tan \varphi \tan \theta), \quad |\tan \varphi \tan \theta| \leq 1, \quad (11)$$

where  $c$  is daily average heat flow coefficient,  $c \approx 0.5$ ;  $t$  is relative daylight time,  $86400 = 24 \times 60 \times 60$  is number of seconds in a day.

The computation for relative daily light period is presented in Fig. 7.

The heat loss flow per 1 m<sup>2</sup> of dome film cover by convection and heat conduction is (see [19]):

$$q = k(t_1 - t_2), \quad \text{where } k = \frac{1}{1/\alpha_1 + \sum_i \delta_i / \lambda_i + 1/\alpha_2}, \quad (12)$$

where  $k$  is heat transfer coefficient, W/m<sup>2</sup>K;  $t_{1,2}$  are temperatures of the inter and outer multi-layers of the heat insulators, °C;  $\alpha_{1,2}$  are convection coefficients of the inter and outer multi-layers of heat insulators ( $\alpha = 30 \div 100$ ), W/m<sup>2</sup>K;  $\delta_i$  are thickness of insulator layers;  $\lambda_i$  are coefficients of heat transfer of insulator layers (see Table 1), m;  $t_{1,2}$  are temperatures of initial and final layers °C.

The radiation heat flow per 1 m<sup>2</sup>s of the service area computed by equations (7):

$$q = C_r \left[ \left( \frac{T_1}{100} \right)^4 - \left( \frac{T_2}{100} \right)^4 \right], \quad \text{where } C_r = \frac{c_s}{1/\varepsilon_1 + 1/\varepsilon_2 - 1}, \quad c_s = 5.67 \text{ [W/m}^2\text{K}^4], \quad (13)$$

where  $C_r$  is general radiation coefficient,  $\varepsilon$  are black body rate (Emittance) of plates (see Table 2);  $T$  is temperatures of plates, °K.

The radiation flow across a set of the heat reflector plates is computed by equation

$$q = 0.5 \frac{C'_r}{C_r} q_r, \quad (14)$$

where  $C'_r$  is computed by equation (8) between plate and reflector.

The data of some construction materials is found in Table 1, 2.

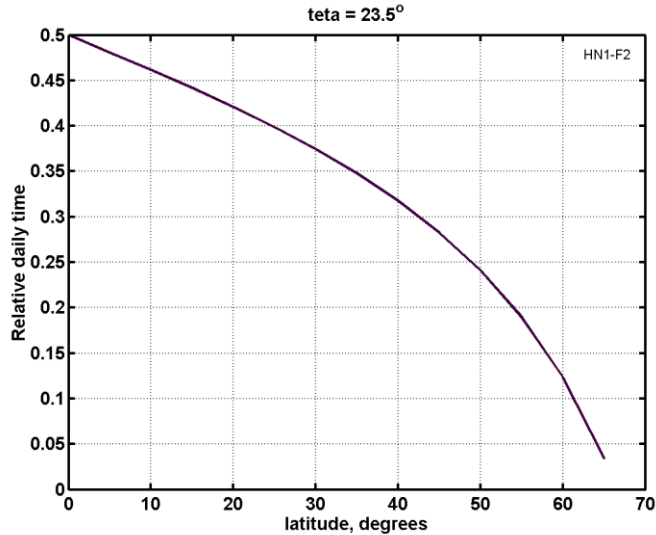


Fig.7. Relative daily light time relative to Earth latitude.

Table 1. [19], p.331. Heat Transfer.

Material	Density, $\text{kg/m}^3$	Thermal conductivity, $\lambda$ , $\text{W/m} \cdot ^\circ\text{C}$	Heat capacity, $\text{kJ/kg} \cdot ^\circ\text{C}$
Concrete	2300	1.279	1.13
Baked brick	1800	0.758	0.879
Ice	920	2.25	2.26
Snow	560	0.465	2.09
Glass	2500	0.744	0.67
Steel	7900	45	0.461
Air	1.225	0.0244	1

As the reader will see, the air layer is the best heat insulator. We do not limit its thickness  $\delta$ .

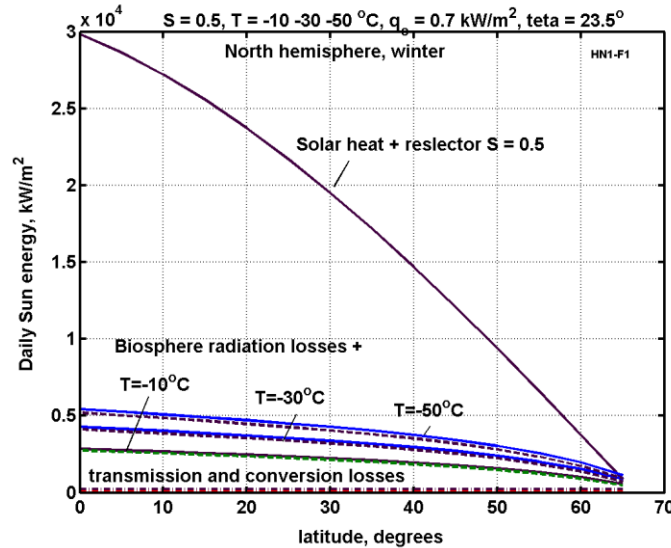
Table 2. Nacshekin (1969), p. 465. Emittance,  $\varepsilon$  (Emissivity)

Material	Temperature, $T$ $^\circ\text{C}$	Emittance, $\varepsilon$
Bright Aluminum	50 ÷ 500 $^\circ\text{C}$	0.04 - 0.06
Bright copper	20 ÷ 350 $^\circ\text{C}$	0.02
Steel	50 $^\circ\text{C}$	0.56
Asbestos board	20 $^\circ\text{C}$	0.96
Glass	20 ÷ 100 $^\circ\text{C}$	0.91 - 0.94
Baked brick	20 $^\circ\text{C}$	0.88 - 0.93
Tree	20 $^\circ\text{C}$	0.8 - 0.9
Black vanish	40 ÷ 100 $^\circ\text{C}$	0.96 - 0.98
Tin	20 $^\circ\text{C}$	0.28

As the reader will notice, the shiny aluminum louver coating is an excellent mean jalousie (louvered window, providing a similar service to a Venetian blind) which serves against radiation losses from the dome.

The general radiation heat  $Q$  computes by equation [11]. Equations [6] – [14] allow computation of the heat balance and comparison of incoming heat (gain) and outgoing heat (loss).

The computations of heat balance of a dome of any size in the coldest wintertime of the Polar Regions are presented in Fig. 8.



**Fig. 8.** Daily heat balance through 1 m<sup>2</sup> of dome during coldest winter day versus Earth's latitude (North hemisphere example). Data used for computations (see Eq. (6) - (14)): temperature inside of dome is  $t_1 = +20$  °C, outside are  $t_2 = -10, -30, -50$  °C; reflectivity coefficient of mirror is  $c_2 = 0.9$ ; coefficient transparency of film is  $c_1 = 0.9$ ; convectively coefficients are  $\alpha_1 = \alpha_2 = 30$ ; thickness of film layers are  $\delta_1 = \delta_2 = 0.0001$  m; thickness of air layer is  $\delta = 1$  m; coefficient of film heat transfer is  $\lambda_1 = \lambda_3 = 0.75$ , for air  $\lambda_2 = 0.0244$ ; ratio of cover blackness  $\varepsilon_1 = \varepsilon_3 = 0.9$ , for louvers  $\varepsilon_2 = 0.05$ .

The heat from combusted fuel is found by equation

$$Q = c_t m / \eta, \quad (15)$$

where  $c_t$  is heat rate of fuel [J/kg];  $c_t = 40$  MJ/kg for liquid oil fuel;  $m$  is fuel mass, kg;  $\eta$  is efficiency of heater,  $\eta = 0.5 - 0.8$ .

In Fig. 8 the alert reader has noticed: the daily heat loss is about the solar heat in the very coldest Winter day when a dome located above 60° North or South Latitude and the outside air temperature is  $-50$  °C.

**7. Properties and Cost of material.** The cost some material are presented in Table 3 (2005-2007). Properties are in Table 4. Some difference in the tensile stress and density are result the difference sources, models and trademarks.

**Table 3.** Average cost of material (2005-2007)

Material	Tensile stress, MPa	Density, g/cm <sup>3</sup>	Cost USD \$/kg
<b>Fibers:</b>			
Glass	3500	2.45	0.7
Kevlar 49, 29	2800	1.47	4.5
PBO Zylon AS	5800	1.54	15
PBO Zylon HM	5800	1.56	15
Boron	3500	2.45	54
SIC	3395	3.2	75
Saffil (5% SiO <sub>2</sub> +Al <sub>2</sub> O <sub>3</sub> )	1500	3.3	2.5
<b>Matrices:</b>			

Polyester	35	1,38	2
Polyvinyl	65	1.5	3
Aluminum	74-550	2.71	2
Titanium	238-1500	4.51	18
Borosilicate glass	90	2.23	0.5
Plastic	40-200	1.5-3	2 - 6
<b>Materials:</b>			
Steel	500 - 2500	7.9	0.7 - 1
Concrete	-	2.5	0.05
Cement (2000)	-	2.5	0.06-0.07
Melted Basalt	35	2.93	0.005

**Table 4.** Material properties

Material	Tensile strength kg/mm <sup>2</sup>	Density g/cm <sup>3</sup>	Fibers	Tensile strength kg/mm <sup>2</sup>	Density g/cm <sup>3</sup>
<b>Whiskers</b>					
AlB <sub>12</sub>	2650	2.6	QC-8805	620	1.95
B	2500	2.3	TM9	600	1.79
B <sub>4</sub> C	2800	2.5	Allien 1	580	1.56
TiB <sub>2</sub>	3370	4.5	Allien 2	300	0.97
SiC	1380-4140	3.22	Kevlar or Twaron	362	1.44
<b>Material</b>			Dynecta or Spectra	230-350	0.97
Steel prestressing strands	186	7.8	Vectran	283-334	0.97
Steel Piano wire	220-248		E-Glass	347	2.57
Steel A514	76	7.8	S-Glass	471	2.48
Aluminum alloy	45.5	2.7	Basalt fiber	484	2.7
Titanium alloy	90	4.51	Carbon fiber	565	1,75
Polypropylene	2-8	0.91	Carbon nanotubes	6200	1.34

Source: Howatson A.N., Engineering Tables and Data, p.41.

**8. Closed-loop water cycle.** The closed Dome allows creating a closed loop cycle, when vapor water in the day time will returns as condensation or dripping rain in the night time. A reader can derive the equations below from well-known physical laws Nacshekin [19](1969). Therefore, the author does not give detailed explanations of these.

**Amount of water in atmosphere.** Amount of water in atmosphere depends upon temperature and humidity. For relative humidity 100%, the maximum partial pressure of water vapor for pressure 1 atm is shown in Table 5.

**Table 5.** Maximum partial pressure of water vapor in atmosphere for given air temperature (pressure is 1 atm)

<i>t</i> , C	-10	0	10	20	30	40	50	60	70	80	90	100
<i>p</i> ,kPa	0.287	0.611	1.22	2.33	4.27	7.33	12.3	19.9	30.9	49.7	70.1	101

The amount of water in 1 m<sup>3</sup> of air may be computed by equation

$$m_w = 0.00625 [p(t_2)h - p(t_1)], \quad (16)$$

where  $m_w$  is mass of water, kg in 1 m<sup>3</sup> of air;  $p(t)$  is vapor (steam) pressure from Table 4, relative  $h = 0 \div 1$  is relative humidity. The computation of equation (16) is presented in fig.9. Typical relative humidity of atmosphere air is 0.5 - 1.

**Computation of closed-loop water cycle.** Assume the maximum safe temperature is achieved in the daytime. When dome reaches the maximum (or given) temperature, the control system fills with air the space 5 (Fig.3) between double-layers of the film cover. That protects the inside part of the dome from further heating by outer (atmospheric) hot air. The control system decreases also the solar radiation input, increasing reflectivity of the liquid crystal layer of the film cover. That way, we can support a constant temperature inside the dome.

The **heating** of the dome in the daytime may be computed by equations:

$$q(t) = q_0 \sin(\pi t / t_d), \quad dQ = q(t)dt, \quad Q = \int_0^{t_d} dQ, \quad Q(0) = 0, \quad M_w = \int_0^{t_d} a dT, \quad (17)$$

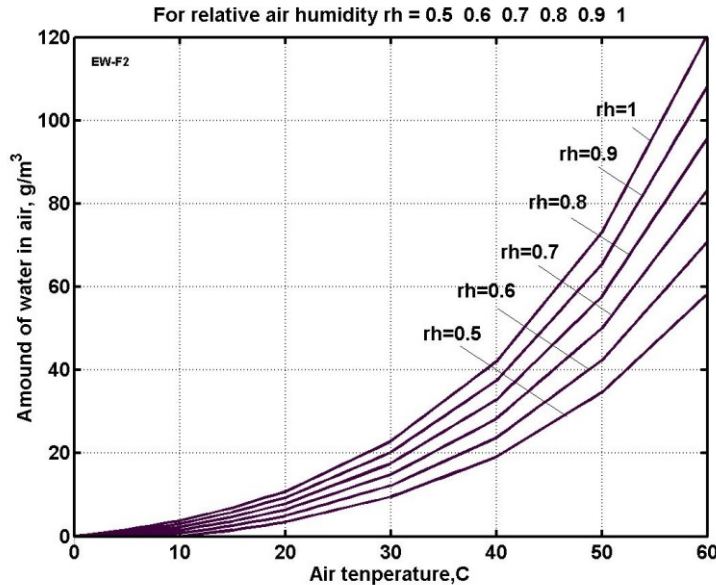
$$dT = \frac{dQ}{C_{p1}\rho_1\delta_1 + C_{p2}\rho_2H + rHa}, \quad a = 10^{-5}(5.28T + 2), \quad T = \int_0^{t_d} dT, \quad T(0) = T_{min},$$

where  $q$  is heat flow,  $J/m^2 s$ ;  $q_0$  is maximal Sun heat flow in daily time,  $q_0 \approx 100 \div 900, J/m^2 s$ ;  $t$  is time,  $s$ ;  $t_d$  is daily (Sun) time,  $s$ ;  $Q$  is heat,  $J$ ;  $T$  is temperature in dome (air, soil),  $^{\circ}C$ ;  $C_{p1}$  is heat capacity of soil,  $C_{p1} \approx 1000 J/kg$ ;  $C_{p2} \approx 1000 J/kg$  is heat capacity of air;  $\delta_1 \approx 0.1 m$  is thickness of heating soil;  $\rho_1 \approx 1000 kg/m^3$  is density of the soil;  $\rho_2 \approx 1.225 kg/m^3$  is density of the air;  $H$  is thickness of air (height of cover),  $H \approx 5 \div 300 m$ ;  $r = 2,260,000 J/kg$  is evaporation heat,  $a$  is coefficient of evaporation;  $M_w$  is mass of evaporation water,  $kg/m^3$ ;  $T_{min}$  is minimal temperature into dome after night,  $^{\circ}C$ .

The convective (conductive) cooling of dome at night time may be computed as below

$$q_t = k(T_{min} - T(t)), \quad \text{where} \quad k = \frac{1}{1/\alpha_1 + \sum_i \delta_i / \lambda_i + 1/\alpha_2} \quad (18)$$

where  $q_t$  is heat flow through the dome cover by convective heat transfer,  $J/m^2 s$  or  $W/m^2$ ; see the other notation in Eq. (12). We take  $\delta = 0$  in night time (through active control of the film).



**Fig. 9.** Amount of water in 1 m<sup>3</sup> of air versus air temperature and relative humidity (rh).  $t_l = 0^{\circ}C$ .

The radiation heat flow  $q_r$  (from dome to night sky, radiation cooling) may be estimated by equations (10).

$$q_r = C_r \left[ \left( \frac{T_{\min}}{100} \right)^4 - \left( \frac{T(t)}{100} \right)^4 \right], \quad \text{where } C_r = \frac{c_s}{1/\varepsilon_1 + 1/\varepsilon_2 - 1}, \quad c_s = 5.67 \text{ [W/m}^2\text{K}^4\text{]}, \quad (19)$$

where  $q_r$  is heat flow through dome cover by radiation heat transfer, J/m<sup>2</sup>s or W/m<sup>2</sup>; see the other notation in Eq. (10). We take  $\varepsilon = 1$  in night time (through active control of the film).

The other equations are same (17)

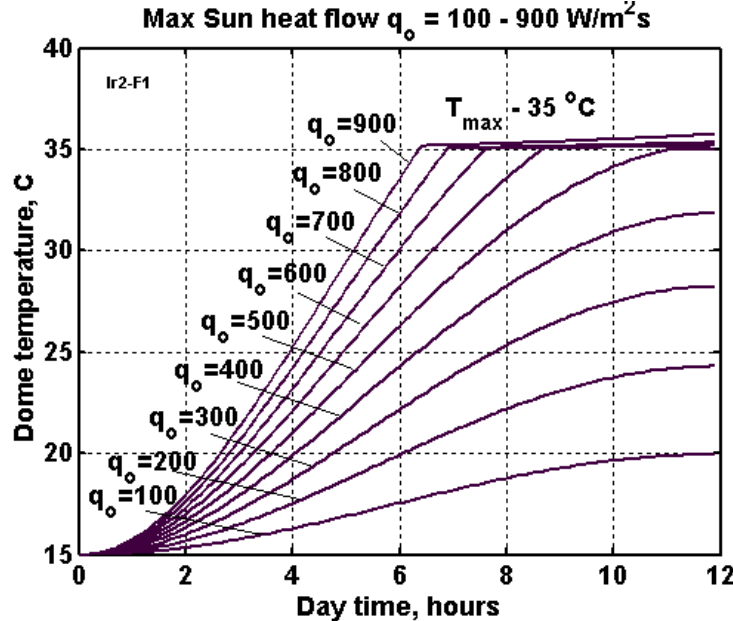
$$dQ = [q_t(t) + q_r(t)]dt, \quad Q = \int_0^{t_d} dQ, \quad Q(0) = 0, \quad M_w = \int_0^{t_d} a dT, \quad (20)$$

$$dT = \frac{dQ}{C_{p1}\rho_1\delta_1 + C_{p2}\rho_2H + rHa}, \quad a = 10^{-5}(5,28T + 2), \quad T = \int_0^{t_d} dT, \quad T(0) = T_{\min},$$

Let us take the following parameters:  $H = 135$  m,  $\alpha = 70$ ,  $\delta = 1$  m between cover layers,  $\lambda = 0.0244$  for air. Result of computation for given parameter are presented in figs. 10 – 11.

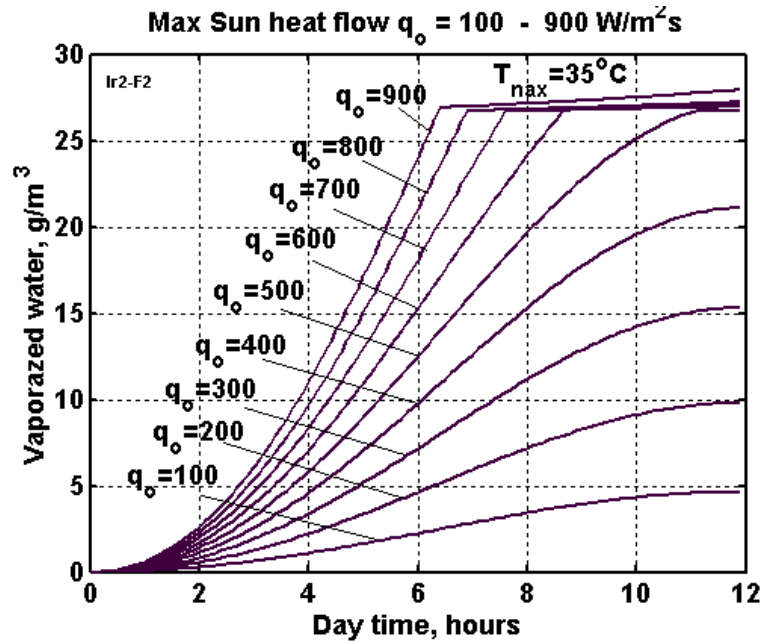
For dome cover height  $H = 135$  m the night precipitation (maximum) is  $0.027 \times 135 = 3.67$  kg (liter) or 3.67 mm/day (Fig.12). The AB Dome's internal annual precipitation under these conditions is 1336.6 mm (maximum). If it is not enough, we can increase the height of dome cover. The globally-averaged annual precipitation is about 1000 mm on Earth.

As you see, we can support the same needed temperature in a wide range of latitudes at summer and winter time. That means the covered regions are not hostage to their location upon the Earth's surface (up to latitude  $20^\circ - 30^\circ$ ), nor Earth's seasons, nor it is dependant upon outside weather. Our design of Dome is not optimal, but rather selected for realistic parameters.



**Fig. 10.** Heating of the dome by solar radiation from the night temperature of  $15^\circ\text{C}$  to  $35^\circ\text{C}$  via daily maximal solar radiation ( $\text{W/m}^2$ ) for varying daily time. Height of dome film cover equals  $H = 135$  m. The control temperature system limits the maximum internal dome temperature to  $35^\circ\text{C}$ .





**Fig.11.** Water vaporization for 100% humidity of the air for different maximal solar radiation ( $W/m^2$ ) levels delivered over varying daily time. Height of dome film cover equals  $H = 135$  m. The temperature control system limits the maximum internal dome temperature to 35 C.

## Projects

### Project 1. Manhattan (district of New-York, USA).

**Manhattan Island**, in New York Harbor, is the largest part of the Borough of Manhattan, one of the Five Boroughs which form the City of New York. With a 2007 population of 1,620,867 living in a land area of 22.96 square miles (59.47  $km^2$ ), New York County is the most densely populated county in the United States at 70,595 residents per square mile (27,267/ $km^2$ ). It is also one of the wealthiest counties in the United States, with a 2005 personal per capita income above \$100,000.

Area (land) of Manhattan is 22.96 sq mi (59.5  $km^2$ ,  $A \approx 60$   $km^2$ ), population 1,620,867 inhabitants, density 70,595/sq mi (27,256.9/ $km^2$ ).

Average annual high temperature is 17C (62F), average annual low temperature is 8C (47F). The average high monthly temperature is 30C (July), the average low monthly temperature is -4C (January). Annual rainfall is 1,124 mm.

#### Computation and estimation of cost:

**Film.** Requested area of double film is  $A_f = 3 \times 60$   $km^2 = 180$   $km^2$ . If thickness of film is  $\delta = 0.1$  mm, specific density  $\gamma = 1800$   $kg/m^3$ , the mass of film is  $M = \gamma \delta A_f = 32,500$  tons or  $m = 0.54$   $kg/m^2$ . If cost of film is  $c$  - \$2/kg, the total cost of film is  $C_f = cM = \$65$  millions or  $c_a = \$1.08/m^2$ .

If average thickness of a gas layer inside the AB-Blanket is  $\delta = 3$  m, the total volume of gas is  $V = \delta A = 1.8 \times 10^8$   $m^3$ . One  $m^3$  of methane ( $CH_4$ ) has lift force  $l = 0.525$   $kg/m^3$  or Blanket of thickness  $\delta = 3$  m has lift force  $l = 1.575$   $kg/m^2$  or the total Blanket lift force is  $L = 94.5 \times 10^3$  tons. Cost of methane is  $c = \$0.4/m^3$ , volume is  $V = \delta A = 1.8 \times 10^8$   $m^3$ . But we did not take in account because after finishing building the AB Dome the methane will be changed for overpressured air. (Thus \$72 million in methane would not be kept in inventory, but if the AB-Blankets were each 1% of the final area, neglecting leaks only \$720,000 worth of methane would be in play at any one time. With some designs step by step methane replacement with air will be possible (if overpressure support is introduced

another way, etc.)

**Support cables.** Let us take an additional air pressure as  $p = 0.01 \text{ atm} = 1000 \text{ N/m}^2$ , safety tensile stress of artificial fiber  $\sigma = 100 \text{ kG/mm}^2$ , specific density  $\gamma = 1800 \text{ kg/m}^3$ ,  $s = 1 \text{ m}^2$ , and altitude of the Blanket  $h = 500 \text{ m}$ . Then needed cross-section of cable is  $1 \text{ mm}^2$  per  $1 \text{ m}^2$  of Blanket and mass of the support cable is  $m = \gamma ph/\sigma = 0.9 \text{ kg}$  per  $1 \text{ m}^2$  of Blanket. If cost of fiber is  $\$1/\text{kg}$ , the cost of support cable is  $c_c = \$0.9/\text{m}^2$ . Total mass of the support cables is 54,000 tons.

The average cost of air and water **tubes and control system** we take  $c_t = \$0.5/\text{m}^2$ .

The **total cost** of  $1 \text{ m}^2$  material is  $C = c_a + c_c + c_t = 1.08 + 0.9 + 0.5 = \$2.48/\text{m}^2 \approx \$2.5/\text{m}^2$  or  $\$150$  millions of the USA dollars for Manhattan area. The work will cost about  $\$100$  million. *The total cost of Blanket construction for Manhattan is about **\\$250 million** US dollars.*

The clean (rain) water is received from  $1 \text{ m}^2$  of covered area is  $1.1 \text{ kL/year}$ . That is enough for the Manhattan population. The possible energy (if we install at extra expense hydro-electric generators and utilize pressure (50 atm) of the rain water) is about  $4000 \text{ kJ/m}^2$  in year. That covers about 15% of city consumption.

Manhattan receives a permanent warm climate and saves a lot of fuel for home heating (decreased pollution of atmosphere) in winter time and save a lot of electric energy for home cooling in the summer time.

## Project 2. Moscow (Russia)

Area (land) of Moscow is  $1,081 \text{ km}^2$  ( $417.4 \text{ sq mi}$ ), population (as of the 2002 Census) 10,470,318 inhabitants, density  $9,685.8/\text{km}^2$  ( $25,086.1/\text{sq mi}$ ).

Average annual high temperature is  $9.1\text{C}$ , average annual low temperature is  $2.6\text{C}$ . The average high monthly temperature is  $24\text{C}$  (July)(Record is  $36.5\text{C}$ ), the average low monthly temperature is  $-8\text{C}$  (January)(Record low is  $-42.2\text{C}$ ). Annual rainfall is  $705 \text{ mm}$ .

**Estimation.** The full Moscow area is significantly more the Manhattan area (by 18 times) and has less population density (by 3 times). We can cover only the most important central part of Moscow, the place where are located the Government and business offices, tourist hotels, theaters and museums. If this area equals  $60 \text{ km}^2$  the cost of construction will be cheaper than  $\$250$  million US because the labor cost less (by 3 -5 times) then the USA. But profit from Moscow Blanket may be more then from the Manhattan cover because the weather is colder in Moscow than in New York.

## DISCUSSION

As with any innovative macro-project proposal, the reader will naturally have many questions. We offer brief answers to the most obvious questions our readers are likely to ponder.

### (1) *The methane gas is fuel. How about fire protection?*

The AB Blanket is temporarily filled by methane gas for air delivery and period of Dome construction. After finish of dome construction the methane will be changed by air and the Blanket will be supported at altitude by small additional air pressure into AB-Dome.

The second reason: the Blanket contains methane in small separated cylindrical sections (in piece  $100 \times 100 \text{ m}$  has about 30 these sections, see fig.2) and every piece has special anti-fire margins (fig.2). If one cylindrical section will be damaged, the gas flows up (it is lighter then air), burns down only from this section (if film cannot easy burn) and piece get only hole. In any case the special margins do not allow the fire to set fire to next pieces.

### (2) *Carbonic acid (smoke, $\text{CO}_2$ ) from industry and cars will pollute air into dome.*

The smoke from industry can be deleted out from dome by film tubes acting as feedthroughs (chimneys) to the outer air. The cars (exhaust pipes) can be provided by a carbonic acid absorber. The evergreen plants into Dome will intensely absorb  $\text{CO}_2$  especially if concentration of  $\text{CO}_2$  will be over the regular values in conventional atmosphere (but safe for people). We can also

periodically ventilate the Dome in good weather by open the special windows in Dome (see fig.1) and turn on the ventilators like we ventilate the apartment. We can install heat exchangers and permanently change the air in the dome (periodically wise to do anyway because of trace contaminant buildups).

(3) *How can snow be removed from Dome cover?*

We can pump a warm air between the Blanket layers and melt show and pass the water by rain tubes. We can drop the snow by opening the Blanket windows (fig.2d).

(4) *How can dust be removed from the Dome cover?*

The Blanket is located at high altitude (about 500 m). Air at this altitude has but little dust. The dust that does infall and stick may be removed by rain, washdown tubes or air flow from blowers or even a helicopter close pass.

(5) *Storm wind overpressures?*

The storm wind can only be on the bounding (outside) sections of dome. Dome has special semi-spherical and semi-cylindrical form factor. We can increase the internal pressure in storm time to add robustness.

(6) *Cover damage.*

The envelope contains a rip-stop cable mesh so that the film cannot be damaged greatly. Electronic signals alert supervising personnel of any rupture problems. The needed part of cover may be reeled down by control cable and repaired. Dome has independent sections.

## Conclusion

The building of gigantic inflatable AB-Dome over an empty flat surface is not difficult. The cover spreads on said flat surface and a ventilator pumps air under the cover (the edges being joined and secured gas-tight) and the overpressure, over many hours, lifts the dome. However, if we want to cover a city, garden, forest we cannot easily spread the thin film over building or trees. In given article is suggested a new method which solves this problem. Idea is in design the double film Blanket filled by light gas (methane, hydrogen, helium). Subassemblies of the AB Dome, known as AB Blankets, are lighter then air and fly in atmosphere. They can be made on a flat area and delivered by dirigible or helicopter to the sky over the city. Here they are connected to the AB Dome under construction, cover the city and protect it from bad weather, chemical, biological and radioactive weapons and particulate falls. After finish of building the light gas can be changed by air.

## References

(The reader may find some of these articles at the author's web page: <http://Bolonkin.narod.ru/p65.htm>, <http://arxiv.org> , search term "Bolonkin", in the book "*Non-Rocket Space Launch and Flight*", Elsevier, London, 2006, 488 pgs., in book "*New Concepts, Ideas, Innovations in Aerospace, Technology and Human Science*", NOVA, 2007, 502 pgs., and in book "*Macro-Projects: Environment and Technology*", NOVA, 2008, 500 pgs.)

1. Bolonkin, A.A., (2003), "Optimal Inflatable Space Towers with 3-100 km Height", *Journal of the British Interplanetary Society* Vol. 56, pp. 87 - 97, 2003.
2. Bolonkin A.A., Cathcart R.B., (2006a), Inflatable 'Evergreen' Polar Zone Dome (EPZD) Settlements, 2006, <http://arxiv.org> search term is "Bolonkin".
3. Bolonkin, A.A., (2006b), Control of Regional and Global Weather, 2006, <http://arxiv.org> search for "Bolonkin".
4. Bolonkin A.A., (2006d), Cheap Textile Dam Protection of Seaport Cities against Hurricane Storm Surge Waves, Tsunamis, and Other Weather-Related Floods, 2006. <http://arxiv.org>.
5. Cathcart R.B. and Bolonkin, A.A., (2006e), Ocean Terracing, 2006. <http://arxiv.org>.
6. Bolonkin A.A., (2006g), *Non-Rocket Space Launch and Flight*, Elsevier, London, 2006, 488 ps.

7. Bolonkin, A.A. and R.B. Cathcart, (2006i), Inflatable 'Evergreen' Dome Settlements for Earth's Polar Regions. Clean Technologies and Environmental Policy. DOI 10.1007/s10098.006-0073.4.
8. *Macro-Engineering: A Challenge for the Future*. Springer, (2006). 318 pages. Collection of articles. See articles of A. Bolonkin and R. Cathcart.
9. Bolonkin A.A., Cathcart R.B., (2007b), Inflatable 'Evergreen' dome settlements for Earth's Polar Regions. Journal "Clean Technologies and Environmental Policy", Vol 9, No. 2, May 2007, pp.125-132.
10. Bolonkin, A.A., (2007c), "*New Concepts, Ideas, and Innovations in Aerospace, Technology and Human Life*". NOVA, 2007, 502 pgs.
11. Bolonkin A.A., (2007e), AB Method of Irrigation without Water (Closed-loop water cycle). Presented to <http://arxiv.org> in 2007 search "Bolonkin".
12. Bolonkin A.A., (2007f), Inflatable Dome for Moon, Mars, Asteroids and Satellites, Presented as paper AIAA-2007-6262 by AIAA Conference "Space-2007", 18-20 September 2007, Long Beach. CA, USA.
13. Bolonkin, A.A., (2007h), Cheap artificial AB-Mountains, Extraction of Water and Energy from Atmosphere and Change of Country Climate <http://arxiv.org>, 2007.
14. Bolonkin, A.A.,(2007i) "Optimal Inflatable Space Towers with 3-100 km Height", *Journal of the British Interplanetary Society* Vol. 56, pp. 87 - 97, 2003.
15. Bolonkin, A.A., Cathcart R.B., (2008b), *Macro-Projects: Environment and Technology*. NOVA, 500 pgs.
16. Bolonkin A.A., Cheap Method of City Protection from Rockets and Nuclear Warheads. <http://arxiv.org> search "Bolonkin". 2007.
17. Bolonkin A.A., Cheap Artificial AB-Mountains, Extraction of Water and Energy from Atmosphere and Change of Regional Climate. Presented to <http://arxiv.org> in 2007 search "Bolonkin".
18. Gleick, Peter; et al. (1996). [Encyclopedia of Climate and Weather](#). Oxford University Press.
19. Nасhekin, V.V., (1969), Technical thermodynamic and heat transmission. Public House High University, Moscow. 1969 (in Russian).
17. *Wikipedia*. Some background material in this article is gathered from Wikipedia under the Creative Commons license.





Current air support structures



Inside of inflatable structure. New technologies allowed the Generations Sports Complex to cover an area 2 football fields in length by almost a football field wide without support columns to get in the way





Inside of inflatable structure



Current big Inflatable structures



Fstructures.com

Current middle inflatable dome



Small inflatable structure



Left: Possibility of inflatable structure



Right: Inside of botanic garden





Artificial beach



Exhibition hall

## Chapter 7

# Live of Humanity in Outer Space without Space Suite

## Abstract

The author proposes and investigates his old idea - a living human in space without the encumbrance of a complex space suit. Only in this condition can biological humanity seriously attempt to colonize space because all planets of Solar system (except the Earth) do not have suitable atmospheres. Aside from the issue of temperature, a suitable partial pressure of oxygen is lacking. In this case the main problem is how to satiate human blood with oxygen and delete carbonic acid gas (carbon dioxide). The proposed system would enable a person to function in outer space without a space suit and, for a long time, without food. That is useful also in the Earth for sustaining working men in an otherwise deadly atmosphere laden with lethal particulates (in case of nuclear, chemical or biological war), in underground confined spaces without fresh air, under water or a top high mountains above a height that can sustain respiration.

**Key words:** Space suit, space colonization, space civilization, life on Moon, Mars and other planets, people existing in space.

## Introduction

**Short history.** A fictional treatment of Man in space without spacesuit protection was famously treated by Arthur C. Clarke in at least two of his works, “Earthlight” and the more famous “2001: A Space Odyssey”. In the scientific literature, the idea of sojourning in space without complex space suits was considered seriously about 1970 and an initial research was published in [1] p.335 – 336. Here is more detail research this possibility.

**Humans and vacuum.** Vacuum is primarily an asphyxiant. Humans exposed to vacuum will lose consciousness after a few seconds and die within minutes, but the symptoms are not nearly as graphic as commonly shown in pop culture. Robert Boyle was the first to show that vacuum is lethal to small animals. Blood and other body fluids do boil (the medical term for this condition is ebullism), and the vapour pressure may bloat the body to twice its normal size and slow circulation, but tissues are elastic and porous enough to prevent rupture. Ebullism is slowed by the pressure containment of blood vessels, so some blood remains liquid. Swelling and ebullism can be reduced by containment in a flight suit. Shuttle astronauts wear a fitted elastic garment called the Crew Altitude Protection Suit (CAPS) which prevents ebullism at pressures as low as 15 Torr (2 kPa). However, even if ebullism is prevented, simple evaporation of blood can cause decompression sickness and gas embolisms. Rapid evaporative cooling of the skin will create frost, particularly in the mouth, but this is not a significant hazard.

Animal experiments show that rapid and complete recovery is the norm for exposures of fewer than 90 seconds, while longer full-body exposures are fatal and resuscitation has never been successful.<sup>[4]</sup> There is only a limited amount of data available from human accidents, but it is consistent with animal data. Limbs may be exposed for much longer if breathing is not impaired. Rapid decompression can be much more dangerous than vacuum exposure itself. If the victim holds his breath during decompression, the delicate internal structures of the lungs can be ruptured, causing death. Eardrums may be ruptured by rapid decompression, soft tissues may bruise and seep blood, and the stress of shock will accelerate oxygen consumption leading to asphyxiation.

In 1942, the Nazi regime tortured Dachau concentration camp prisoners by exposing them to vacuum. This was an experiment for the benefit of the German Air Force (Luftwaffe), to determine the human body's capacity to survive high altitude conditions.

Some extremophile microorganisms, such as Tardigrades, can survive vacuum for a period of years.

**Respiration (physiology).** In animal physiology, respiration is the transport of oxygen from the clean air to the tissue cells and the transport of carbon dioxide in the opposite direction. This is in contrast to the biochemical definition of respiration, which refers to cellular respiration: the metabolic process by which an organism obtains energy by reacting oxygen with glucose to give water, carbon dioxide and ATP (energy). Although physiologic respiration is necessary to sustain cellular respiration and thus life in animals, the processes are distinct: cellular respiration takes place in individual cells of the animal, while physiologic respiration concerns the bulk flow and transport of metabolites between the organism and external environment.

In unicellular organisms, simple diffusion is sufficient for gas exchange: every cell is constantly bathed in the external environment, with only a short distance for gases to flow across. In contrast, complex multicellular organisms such as humans have a much greater distance between the environment and their innermost cells, thus, a respiratory system is needed for effective gas exchange. The respiratory system works in concert with a circulatory system to carry gases to and from the tissues.

In air-breathing vertebrates such as humans, respiration of oxygen includes four stages:

- *Ventilation* from the ambient air into the alveoli of the lung.
- *Pulmonary gas exchange* from the alveoli into the pulmonary capillaries.
- *Gas transport* from the pulmonary capillaries through the circulation to the peripheral capillaries in the organs.
- *Peripheral gas exchange* from the tissue capillaries into the cells and mitochondria.

Note that ventilation and gas transport require energy to power mechanical pumps (the diaphragm and heart respectively), in contrast to the passive diffusion taking place in the gas exchange steps.

Respiratory physiology is the branch of human physiology concerned with respiration.

**Respiration system.** In humans and other mammals, the respiratory system consists of the airways, the lungs, and the respiratory muscles that mediate the movement of air into and out of the body. Within the alveolar system of the lungs, molecules of oxygen and carbon dioxide are passively exchanged, by diffusion, between the gaseous environment and the blood. Thus, the respiratory system facilitates oxygenation of the blood with a concomitant removal of carbon dioxide and other gaseous metabolic wastes from the circulation. The system also helps to maintain the acid-base balance of the body through the efficient removal of carbon dioxide from the blood.

**Circulation.** The right side of the heart pumps blood from the right ventricle through the pulmonary semilunar valve into the pulmonary trunk. The trunk branches into right and left pulmonary arteries to the pulmonary blood vessels. The vessels generally accompany the airways and also undergo numerous branchings. Once the gas exchange process is complete in the pulmonary capillaries, blood is returned to the left side of the heart through four pulmonary veins, two from each side. The pulmonary circulation has a very low resistance, due to the short distance within the lungs, compared to the systemic circulation, and for this reason, all the pressures within the pulmonary blood vessels are normally low as compared to the pressure of the systemic circulation loop.

Virtually all the body's blood travels through the lungs every minute. The lungs add and remove



many chemical messengers from the blood as it flows through pulmonary capillary bed. The fine capillaries also trap blood clots that have formed in systemic veins.

**Gas exchange.** The major function of the respiratory system is gas exchange. As gas exchange occurs, the acid-base balance of the body is maintained as part of homeostasis. If proper ventilation is not maintained, two opposing conditions could occur: 1) respiratory acidosis, a life threatening condition, and 2) respiratory alkalosis.

Upon inhalation, gas exchange occurs at the alveoli, the tiny sacs which are the basic functional component of the lungs. The alveolar walls are extremely thin (approx. 0.2 micrometres), and are permeable to gases. The alveoli are lined with pulmonary capillaries, the walls of which are also thin enough to permit gas exchange.

**Membrane oxygenator.** A membrane oxygenator is a device used to add oxygen to, and remove carbon dioxide from the blood. It can be used in two principal modes: to imitate the function of the lungs in cardiopulmonary bypass (CPB), and to oxygenate blood in longer term life support, termed Extracorporeal membrane oxygenation, ECMO. A membrane oxygenator consists of a thin gas permeable membrane separating the blood and gas flows in the CPB circuit; oxygen diffuses from the gas side into the blood, and carbon dioxide diffuses from the blood into the gas for disposal.

The introduction of microporous hollow fibres with very low resistance to mass transfer revolutionised design of membrane modules, as the limiting factor to oxygenator performance became the blood resistance [Gaylor, 1988]. Current designs of oxygenator typically use an extraluminal flow regime, where the blood flows outside the gas filled hollow fibres, for short term life support, while only the [homogeneous](#) membranes are approved for long term use.

**Heart-lung machine.** The heart-lung machine is a mechanical pump that maintains a patient's blood circulation and oxygenation during heart surgery by diverting blood from the venous system, directing it through tubing into an artificial lung (oxygenator), and returning it to the body. The oxygenator removes carbon dioxide and adds oxygen to the blood that is pumped into the arterial system.

**Space suit.** A space suit is a complex system of garments, equipment and environmental systems designed to keep a person alive and comfortable in the harsh environment of outer space. This applies to extra-vehicular activity (EVA) outside spacecraft orbiting Earth and has applied to walking, and riding the Lunar Rover, on the Moon.

Some of these requirements also apply to pressure suits worn for other specialized tasks, such as high-altitude reconnaissance flight. Above Armstrong's Line (~63,000 ft/~19,000 m), pressurized suits are needed in the sparse atmosphere. Hazmat suits that superficially resemble space suits are sometimes used when dealing with biological hazards.

A conventional space suit must perform several functions to allow its occupant to work safely and comfortably. It must provide: A stable internal pressure, Mobility, Breathable oxygen, Temperature regulation, Means to recharge and discharge gases and liquids, Means of collecting and containing solid and liquid waste, Means to maneuver, dock, release, and/or tether onto spacecraft.

**Operating pressure.** Generally, to supply enough oxygen for respiration, a spacesuit using pure oxygen must have a pressure of about 4.7 psi (32.4 kPa), equal to the 3 psi (20.7 kPa) partial pressure of oxygen in the Earth's atmosphere at sea level, plus 40 torr (5.3 kPa) CO<sub>2</sub> and 47 torr (6.3 kPa) water vapor pressure, both of which must be subtracted from the alveolar pressure to get alveolar oxygen partial pressure in 100% oxygen atmospheres, by the alveolar gas equation. The latter two figures add to 87 torr (11.6 kPa, 1.7 psi), which is why many modern spacesuits do not use 3 psi, but 4.7 psi (this is

a slight overcorrection, as alveolar partial pressures at sea level are not a full 3 psi, but a bit less). In spacesuits that use 3 psi, the astronaut gets only  $3 - 1.7 = 1.3$  psi (9 kPa) of oxygen, which is about the alveolar oxygen partial pressure attained at an altitude of 6100 ft (1860 m) above sea level. This is about 78% of normal sea level pressure, about the same as pressure in a commercial passenger jet aircraft, and is the realistic lower limit for safe ordinary space suit pressurization which allows reasonable work capacity.

Movements are seriously restricted in the suits, with a mass of more than 110 kilograms each (Shenzhou 7 space suit). The current space suits are very expensive. Flight-rated NASA spacesuits cost about \$22,000,000. While other models may be cheaper, sale is not currently open even to the wealthy public. Even if spaceflight were free (a huge if) a person of average means could not afford to walk in space or upon other planets.

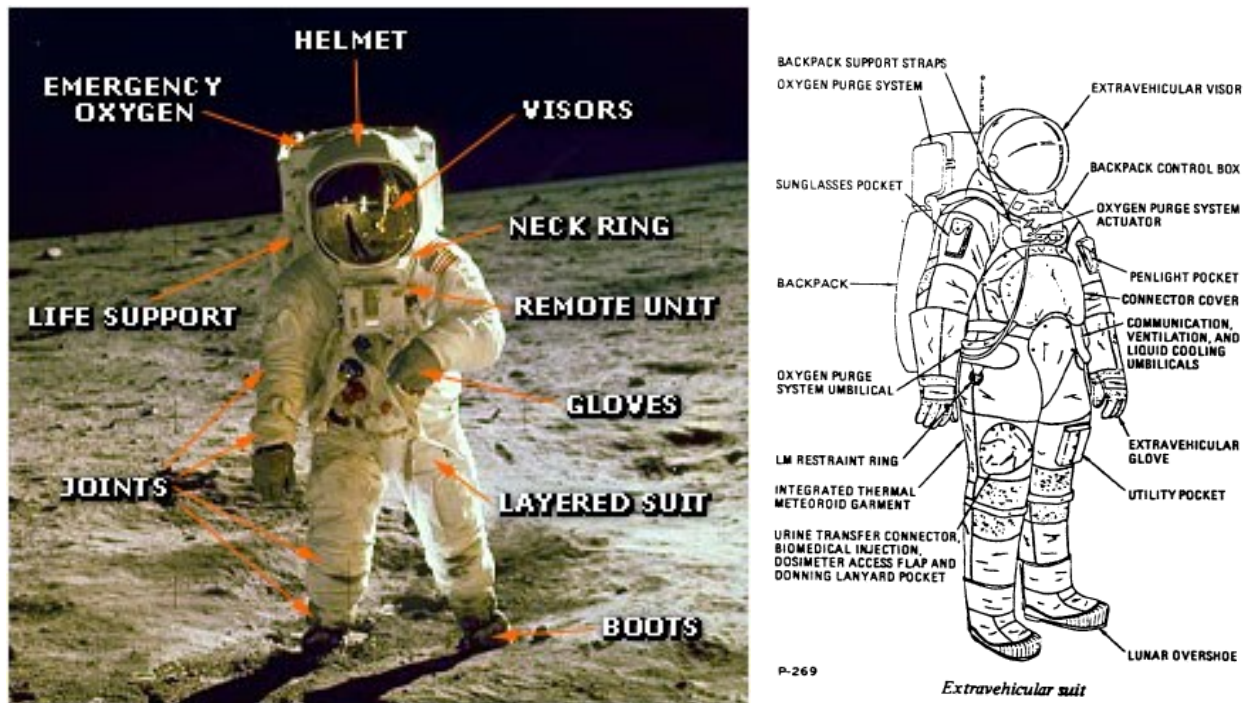


Fig. 1. a. Apollo 11 A7L space suit. b. Diagram showing component parts of A7L space suit.

### Brief Description of Innovation

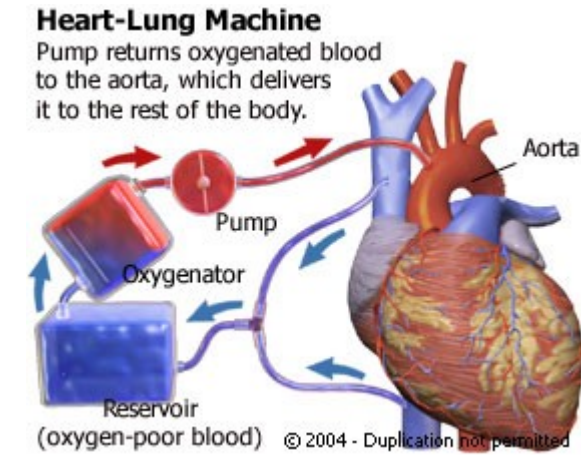
A space suit is a very complex and expensive device (Fig. 1). Its function is to support the person's life, but it makes an astronaut immobile and slow, prevents him or her working, creates discomfort, does not allow eating in space, have a toilet, etc. Astronauts need a space ship or special space habitat located not far from away where they can undress for eating, toilet activities, and rest.

Why do we need a special space suit in outer space? There is only one reason – we need an oxygen atmosphere for breathing, respiration. Human evolution created lungs that aerates the blood with oxygen and remove carbon dioxide. However we can also do that using artificial apparatus. For example, doctors, performing surgery on someone's heart or lungs connect the patient to a heart – lung machine that acts in place of the patient's lungs or heart.

We can design a small device that will aerate the blood with oxygen and remove the carbon dioxide. If a tube from the main lung arteries could be connected to this device, we could turn on (off) the artificial breathing at any time and enable the person to breathe in a vacuum (on an asteroid or planet without atmosphere) in a degraded or poisonous atmosphere, or under water, for a long time. In space

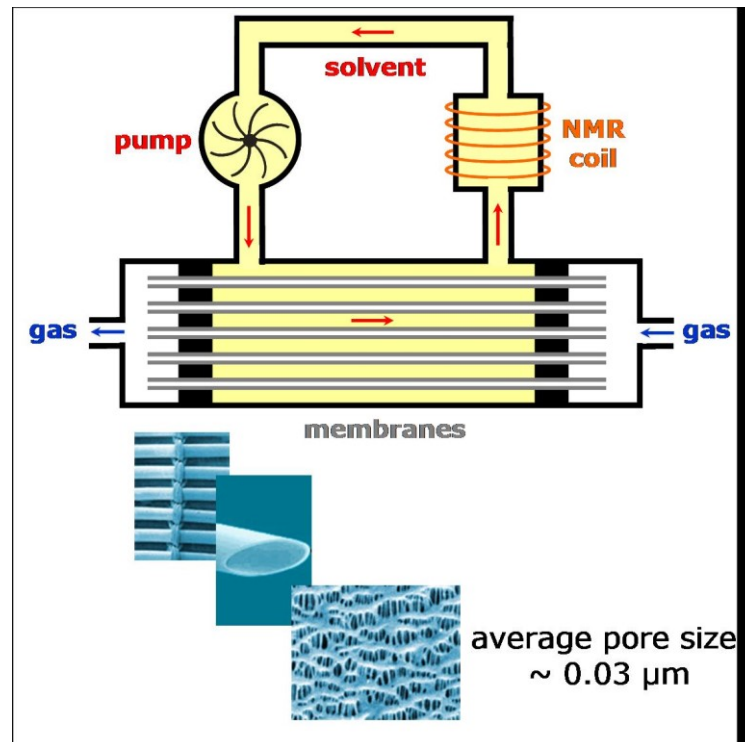
we can use a conventional Earth manufacture oversuit (reminiscent of those used by workers in semiconductor fabs) to protect us against solar ultraviolet light.

The sketch of device which saturates the blood with oxygen and removes the carbon dioxide is presented in fig.2. The Heart-Lung machines are widely used in current surgery.



**Fig.2.** Principal sketch of heart-Lung Machine

The main part of this device is oxygenator, which aerates the blood with oxygen and removes the carbon dioxide. The principal sketch of typical oxygenator is presented in fig. 3.



**Fig.3.** Principal sketch of oxygenator.

Current oxygenator is shown in Fig. 4.

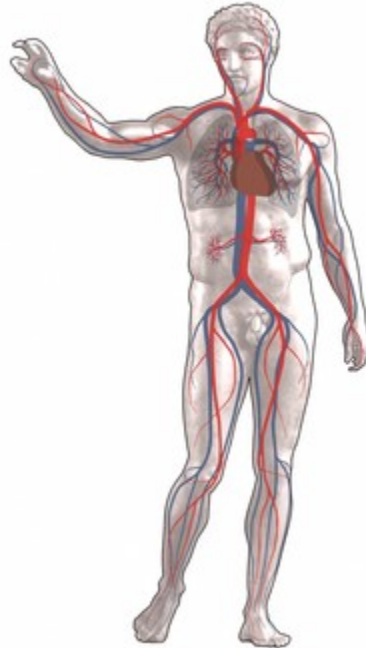
The **circulatory system** is an organ system that moves nutrients, gases, and wastes to and from [cells](#), helps fight diseases and helps stabilize body temperature and pH to maintain homeostasis. This system may be seen strictly as a blood distribution network, but some consider the circulatory system as

composed of the cardiovascular system, which distributes blood, and the lymphatic system, which distributes lymph. While humans, as well as other vertebrates, have a closed cardiovascular system (meaning that the blood never leaves the network of arteries, veins and capillaries), some invertebrate groups have an open cardiovascular system. The most primitive animal phyla lack circulatory systems. The lymphatic system, on the other hand, is an open system.



**Fig. 4.** Oxygenators

The human blood circulatory system is shown in Fig. 5.



**Fig.5.** The human circulatory system. Red indicates oxygenated blood, blue indicates deoxygenated.

The main components of the human circulatory system are the heart, the blood, and the blood vessels. The circulatory system includes: the pulmonary circulation, a "loop" through the [lungs](#) where blood is oxygenated; and the systemic circulation, a "loop" through the rest of the body to provide oxygenated blood. An average adult contains five to six quarts (roughly 4.7 to 5.7 liters) of blood, which consists of plasma that contains red blood cells, white blood cells, and platelets.



Two types of fluids move through the circulatory system: blood and lymph. The blood, heart, and blood vessels form the cardiovascular system. The lymph, lymph nodes, and lymph vessels form the lymphatic system. The cardiovascular system and the lymphatic system collectively make up the circulatory system.

The simplest form of intravenous access is a [syringe](#) with an attached **hollow needle**. The needle is inserted through the skin into a vein, and the contents of the syringe are injected through the needle into the bloodstream. This is most easily done with an arm vein, especially one of the metacarpal veins. Usually it is necessary to use a constricting band first to make the vein bulge; once the needle is in place, it is common to draw back slightly on the syringe to aspirate blood, thus verifying that the needle is really in a vein; then the constricting band is removed before injecting.

When man does not use the outer air pressure in conventional space suite, he not has opposed internal pressure except the heart small pressure in blood. The skin vapor easy stop by film clothes or make small by conventional clothes.

The current lung devices must be re-designed for space application. These must be small, light, cheap, easy in application (using hollow needles, no operation (surgery)!), work a long time in field conditions. Wide-ranging space colonization by biological humanity is impossible without them.

### **Artificial Nutrition.**

Application of offered devices gives humanity a unique possibility to be a long time without conventional nutrition. Many will ask, “who would want to live like that?” But in fact many crew members, military, and other pressured personnel routinely cut short what most would consider normal dining routines. And there are those morbidly obese people for whom dieting is difficult exactly because (in an unfortunate phrase!) many can give up smoking ‘cold turkey’, but few can give up ‘eating cold turkey’! Properly ‘fed’ intravenously, a person could lose any amount of excess weight he needed to, while not suffering hunger pains or the problems the conventional eating cycle causes. It is known that people in a coma may exist some years in artificial nutrition inserted into blood. Let us consider the current state of the art.

**Total parenteral nutrition (TPN)**, is the practice of feeding a person intravenously, bypassing the usual process of eating and digestion. The person receives nutritional formulas containing [salts](#), glucose, amino acids, lipids and added vitamins.

Total parenteral nutrition (TPN), also referred to as Parenteral nutrition (PN), is provided when the gastrointestinal tract is nonfunctional because of an interruption in its continuity or because its absorptive capacity is impaired. It has been used for comatose patients, although enteral feeding is usually preferable, and less prone to complications. Short-term TPN may be used if a person's digestive system has shut down (for instance by Peritonitis), and they are at a low enough weight to cause concerns about nutrition during an extended hospital stay. Long-term TPN is occasionally used to treat people suffering the extended consequences of an accident or surgery. Most controversially, TPN has extended the life of a small number of children born with nonexistent or severely deformed guts. The oldest were eight years old in 2003.

The preferred method of delivering TPN is with a medical infusion pump. A sterile bag of nutrient solution, between 500 mL and 4 L is provided. The pump infuses a small amount (0.1 to 10 mL/hr) continuously in order to keep the vein open. Feeding schedules vary, but one common regimen ramps up the nutrition over a few hours, levels off the rate for a few hours, and then ramps it down over a few more hours, in order to simulate a normal set of meal times.

Chronic TPN is performed through a central intravenous catheter, usually in the subclavian or jugular vein. Another common practice is to use a PICC line, which originates in the arm, and extends

to one of the central veins, such as the subclavian. In infants, sometimes the umbilical vein is used.

Battery-powered ambulatory infusion pumps can be used with chronic TPN patients. Usually the pump and a small (100 ml) bag of nutrient (to keep the vein open) are carried in a small bag around the waist or on the shoulder. Outpatient TPN practices are still being refined.

Aside from their dependence on a pump, chronic TPN patients live quite normal lives.

Central IV lines flow through a catheter with its tip within a large vein, usually the superior vena cava or inferior vena cava, or within the right atrium of the heart.

There are several types of catheters that take a more direct route into central veins. These are collectively called *central venous lines*.

In the simplest type of central venous access, a catheter is inserted into a subclavian, internal jugular, or (less commonly) a femoral vein and advanced toward the heart until it reaches the superior vena cava or right atrium. Because all of these veins are larger than peripheral veins, central lines can deliver a higher volume of fluid and can have multiple lumens.

Another type of central line, called a Hickman line or Broviac catheter, is inserted into the target vein and then "tunneled" under the skin to emerge a short distance away. This reduces the risk of infection, since bacteria from the skin surface are not able to travel directly into the vein; these catheters are also made of materials that resist infection and clotting.

### Testing

The offered idea may be easily investigated in animals on Earth by using currently available devices. The experiment includes the following stages:

- 1) Using a hollow needle, the main blood system of a good healthy animal connects to a current heart-lung machine.
- 2) The animal is inserted under a transparent dome and air is gradually changed to a neutral gas (for example, nitrogen). If all signs are OK, we may proceed to the following stage some days later.
- 3) The animal is inserted under a transparent dome and air is slowly (tens of minutes) pumped out. If all signs are OK we may start the following stage.
- 4) Investigate how long time the animal can be in vacuum? How quick we can decompress and compress? How long the animal may live on artificial nutrition? And so on.
- 5) Design the lung (oxygenator) devices for people which will be small, light, cheap, reliable, safe, which delete gases from blood (especially those that will cause 'bends' in the case of rapid decompression, and work on decreasing the decompressing time).
- 6) Testing the new devices on animals then human volunteers.

### Advantages of offered system.

The offered method has large advantages in comparison with space suits:

- 1) The lung (oxygenator) devices are small, light, cheaper by tens to hundreds times than the current space suit.
- 2) It does not limit the activity of a working man.
- 3) The working time increases by some times. (less heat buildup, more supplies per a given carry weight, etc)
- 4) It may be widely used in the Earth for existing in poison atmospheres (industry, war), fire, rescue operation, under water, etc.
- 5) Method allows permanently testing (controlling) the blood and immediately to clean it from any poison and gases, wastes, and so on. That may save human lives in critical medical situations and in fact it may become standard emergency equipment.
- 6) For quick save the human life.

- 7) Pilots for high altitude flights.
- 8) The offered system is a perfect rescue system because you turn off from environment and exist INDEPENDENTLY from the environment. (Obviously excluding outside thermal effects, fires etc—but for example, many fire deaths are really smoke inhalation deaths; the bodies are often not burned to any extent. In any case it is much easier to shield searing air from the lungs if you are not breathing it in!)

### Conclusion.

The author proposes and investigates his old idea – a living human in space without the encumbrance of a complex space suit. Only in this condition can biological humanity seriously attempt to colonize space because all planets of Solar system (except the Earth) do not have suitable atmospheres. Aside from the issue of temperature, a suitable partial pressure of oxygen is lacking. In this case the main problem is how to satiate human blood with oxygen and delete carbonic acid gas (carbon dioxide). The proposed system would enable a person to function in outer space without a space suit and, for a long time, without food. That is useful also in the Earth for sustaining working men in an otherwise deadly atmosphere laden with lethal particulates (in case of nuclear, chemical or biological war), in underground confined spaces without fresh air, under water or a top high mountains above a height that can sustain respiration. There also could be numerous productive medical uses.

### REFERENCES

- (The reader may find some of these articles at the author's web page <http://Bolonkin.narod.ru/p65.htm> and in this book "*Non-Rocket Space Launch and Flight*", Elsevier, London, 2006, 488 pages and in his book "*New Concepts, Ideas, Innovations in Aerospace, Technology and Human Science*", NOVA, 2007, 502 pages and in book "*Macro-Projects: Environment and Technology*", NOVA, 2008, 536 pgs.)
1. Bolonkin A.A., *Non-Rocket Space Launch and Flight*, Elsevier, 2006, 488 pgs.
  2. Bolonkin, A.A., Cathcart R.B., Inflatable 'Evergreen' Polar Zone Dome (EPZD) Settlements, 2006. <http://arxiv.org> search term "Bolonkin".
  3. Bolonkin, A.A. and R.B. Cathcart, Inflatable 'Evergreen' Dome Settlements for Earth's Polar Regions. *Clean Technologies and Environmental Policy*. DOI 10.1007/s10098.006-0073.4.
  4. Bolonkin, A.A., Control of Regional and Global Weather. 2006. <http://arxiv.org> search for "Bolonkin".
  5. Bolonkin, A.A., AB Method of Irrigation without Water (Closed-loop water cycle). 2007. <http://arxiv.org> search for "Bolonkin".
  6. Bolonkin, A.A., Cheap Textile Dam Protection of Seaport Cities against Hurricane Storm Surge Waves, Tsunamis, and Other Weather-Related Floods, 2006. <http://arxiv.org>.
  7. Bolonkin, A.A., Cheap artificial AB-Mountains, Extraction of Water and Energy from Atmosphere and Change of Country Climate <http://arxiv.org>, 2007.
  8. Bolonkin, A.A. and R.B. Cathcart, The Java-Sumatra Aerial Mega-Tramway, 2006. <http://arxiv.org>.
  9. Bolonkin, A.A., "Optimal Inflatable Space Towers with 3-100 km Height", *Journal of the British Interplanetary Society* Vol. 56, pp. 87 - 97, 2003.
  10. Bolonkin A.A., Inflatable Dome for Moon, Mars, Asteroids and Satellites, Presented as paper AIAA-2007-6262 by AIAA Conference "Space-2007", 18-20 September 2007, Long Beach. CA, USA
  11. Bolonkin, A.A., Electrostatic Space Towers, 2007, <http://arxiv.org>, search "Bolonkin".
  12. Bolonkin, A.A., *Non-Rocket Space Launch and Flight*, Elsevier, London, 2006, 488 pages.
  13. Bolonkin, A.A., "New Concepts, Ideas, Innovations in Aerospace, Technology and Human Science", NOVA, 2008, 430 pgs.
  14. *Macro-Engineering: A Challenge for the Future*. Springer, 2006. 318 pages. Collection articles.
  15. Wikipedia. Some background material in this article is gathered from Wikipedia under the Creative Commons license.

## Chapter 8

# Magnetic Space Launcher\*

### Abstract

A method and facilities for delivering payload and people into outer space are presented. This method uses, in general, engines located on a planetary surface. The installation consists of a space apparatus, power drive stations, which include a flywheel accumulator (for storage) of energy, a variable reducer, a powerful homopolar electric generator and electric rails. The drive stations accelerate the apparatus up to hypersonic speed.

The estimations and computations show the possibility of making this project a reality in a short period of time (for payloads which can tolerate high  $g$ -forces). The launch will be very cheap at a projected cost of \$3 - \$5 per pound. The authors developed a theory of this type of the launcher.

**Key words:** space launcher, magnetic launcher, railgun, space accelerator, homopolar electric generator, flywheel accumulator.

\*Presented as paper AIAA-2009-5261 to 45<sup>th</sup> AIAA Joint Propulsion Conference, 2-5 August 2009, Denver, CO, USA.

## 1. Introduction

At present, rockets are used to carry people and payloads into space, or to deliver bombs over long distances. This method is very expensive, and requires a well-developed industry, high technology, expensive fuel, and complex devices.

Other than rockets, methods to reach the space velocities are the space elevator, the hypersonic tube air rocket, cable space accelerator, circle launcher and space keeper, centrifugal launcher [1-9], electrostatic liner accelerator [10]. Several new non-rockets methods were also proposed by one of author at the World Space Congress-2002, Houston, USA, 10-19 October 2002.

The space elevator requires very strong nanotubes, as well as rockets and high technology for the initial development. The tube air rocket and non-rocket systems require more detailed research. The electromagnetic transport system, suggested by Minovich (US Patent, 4,795,113, 3 January, 1989)[11], is not realistic at the present time. It requires a vacuum underground tunnel 1530 kilometers long located at a depth of 40 kilometers. The project requires a power cooling system (because the temperature is very high at this depth), a complex power electromagnetic system, and a huge impulse of energy that is greater than the energy of all the electric generating stations on Earth.

This article suggests a very simple and inexpensive method and installation for launching into space.

This is a new space launcher system for delivering hypersonic speeds. This method uses a homopolar electric generator, any conventional power engines (mechanical, electrical, gas turbines), and flywheels (as storage energy) conveniently located on the ground where suspension of weight is not a factor.

### **General information about previous works regarding to our topic.**

Below is common information useful for understanding proposed ideas and research.

A **rocket** is a vehicle, missile or aircraft which obtains thrust by the reaction to the ejection of fast moving fluid from within a rocket engine. Chemical rockets operate due to hot exhaust gas made from "propellant" acting against the inside of an expansion nozzle. This generates forces that both accelerate the gas to extremely high speed, as well as, since every action has an equal and opposite reaction, generating a large thrust on the rocket.

The history of rockets goes back to at least the 13th century, possibly earlier. By the 20th century it included human spaceflight to the Moon, and in the 21st century rockets have enabled commercial space tourism.

Rockets are used for fireworks and weaponry, as launch vehicles for artificial satellites, human spaceflight and exploration of other planets. While they are inefficient for low speed use, they are, compared to other propulsion systems, very lightweight, enormously powerful and can achieve extremely high speeds.

Chemical rockets contain a large amount of energy in an easily liberated form, and can be very dangerous, although careful design, testing, construction and use can minimise the risks.

A rocket engine is a jet engine that takes all its reaction mass ("*propellant*") from within tankage and forms it into a high speed jet, thereby obtaining thrust in accordance with Newton's third law. Rocket engines can be used for spacecraft propulsion as well as terrestrial uses, such as missiles. Most rocket engines are internal combustion engines, although non combusting forms also exist.

**Railgun.** Scientists use a railgun for high acceleration of a small conducting body. A railgun is a form of gun that converts electrical energy (rather than the more conventional chemical energy from an explosive propellant) into projectile kinetic energy. It is not to be confused with a coilgun (Gauss gun). Rail guns use magnetic force to drive a projectile. Unlike gas pressure guns, rail guns are not limited by the speed of sound in a compressed gas, so they are capable of accelerating projectiles to extremely high speeds (many kilometers per second).

A wire carrying an electrical current, when in a magnetic field, experiences a force perpendicular to the direction of the current and the direction of the magnetic field.

In an electric motor, fixed magnets create a magnetic field, and a coil of wire is carried upon a shaft that is free to rotate. An electrical current flows through the coil causing it to experience a force due to the magnetic field. The wires of the coil are arranged such that all the forces on the wires make the shaft rotate, and so the motor runs.

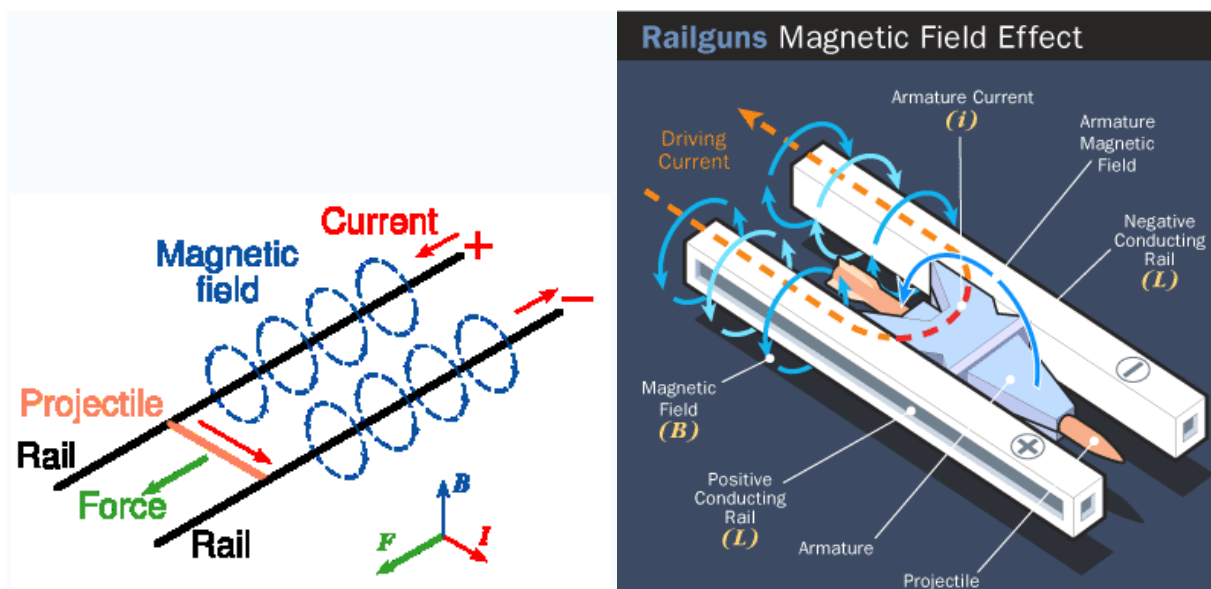


Fig.1. Schematic diagrams of a railgun.

A railgun consists of two parallel metal rails (hence the name) connected to an electrical power supply. When a conductive projectile is inserted between the rails (from the end connected to the power

supply), it completes the circuit. Electrical current runs from the positive terminal of the power supply up the positive rail, across the projectile, and down the negative rail, back to the power supply (Fig. 1).

This flow of current makes the railgun act like an electromagnet, creating a powerful magnetic field in the region of the rails up to the position of the projectile. In accordance with the right-hand rule, the created magnetic field circulates around each conductor. Since the current flows in opposite direction along each rail, the net magnetic field between the rails (**B**) is directed vertically. In combination with the current (**I**) flowing across the projectile, this produces a Lorentz force which accelerates the projectile along the rails. The projectile slides up the rails away from the end with the power supply.

If a very large power supply providing a million amperes or so of current is used, then the force on the projectile will be tremendous, and by the time it leaves the ends of the rails it can be travelling at many kilometres per second. 20 kilometers per second has been achieved with small projectiles explosively injected into the railgun. Although these speeds are theoretically possible, the heat generated from the propulsion of the object is enough to rapidly erode the rails. Such a railgun would require frequent replacement of the rails, or use a heat resistant material that would be conductive enough to produce the same effect.

The need for strong conductive materials with which to build the rails and projectiles; the rails need to survive the violence of an accelerating projectile, and heating due to the large currents and friction involved act against the longevity of the system. The force exerted on the rails consists of a recoil force - equal and opposite to the force propelling the projectile, but along the length of the rails (which is their strongest axis) - and a sideways force caused by the rails being pushed by the magnetic field, just as the projectile is. The rails need to survive this without bending, and thus must be very securely mounted.

The power supply must be able to deliver large currents, with both capacitors and compulsators being common.

The rails need to withstand enormous repulsive forces during firing, and these forces will tend to push them apart and away from the projectile. As rail/projectile clearances increase, electrical arcing develops, which causes rapid vaporization and extensive damage to the rail surfaces and the insulator surfaces. This limits most research railguns to one shot per service interval.

Some have speculated that there are fundamental limits to the exit velocity due to the inductance of the system, and particularly of the rails; but United States government has made significant progress in railgun design and has recently floated designs of a railgun that would be used on a naval vessel. The designs for the naval vessels, however, are limited by their required power usages for the magnets in the rail guns. This level of power is currently unattainable on a ship and reduces the usefulness of the concept for military purposes.

Massive amounts of heat are created by the electricity flowing through the rails, as well as the friction of the projectile leaving the device. This leads to three main problems: melting of equipment, safety of personnel, and detection by enemy forces. As briefly discussed above, the stresses involved in firing this sort of device require an extremely heat-resistant material. Otherwise the rails, barrel, and all equipment attached would melt or be irreparably damaged. Current railguns are not sufficiently powerful to create enough heat to damage anything; however the military is pushing for more and more powerful prototypes. The immense heat released in firing a railgun could potentially injure or even kill bystanders. The heat released would not only be dangerous, but easily detectable. While not visible to the naked eye, the heat signature would be unmistakable to infrared detectors. All of these problems can be solved by the invention of an effective cooling method.

Railguns are being pursued as weapons with projectiles that do not contain explosives, but are given extremely high velocities: 3500 m/s (11,500 ft/s) or more (for comparison, the M16 rifle has a muzzle speed of 930 m/s, or 3,000 ft/s), which would make their kinetic energy equal or superior to the energy yield of an explosive-filled shell of greater mass. This would allow more ammunition to be carried and eliminate the hazards of carrying explosives in a tank or naval weapons platform. Also, by firing at



higher velocities railguns have greater range, less bullet drop and less wind drift, bypassing the inherent cost and physical limitations of conventional firearms - *"the limits of gas expansion prohibit launching an unassisted projectile to velocities greater than about 1.5 km/s and ranges of more than 50 miles [80 km] from a practical conventional gun system."*

If it is even possible to apply the technology as a rapid-fire automatic weapon, a railgun would have further advantages in increased rate of fire. The feed mechanisms of a conventional firearm must move to accommodate the propellant charge as well as the ammunition round, while a railgun would only need to accommodate the projectile. Furthermore, a railgun would not have to extract a spent cartridge case from the breech, meaning that a fresh round could be cycled almost immediately after the previous round has been shot.

**Tests of Railgun.** Full-scale models have been built and fired, including a very successful 90 mm bore, 9 MJ (6.6 million foot-pounds) kinetic energy gun developed by DARPA, but they all suffer from extreme rail damage and need to be serviced after every shot. Rail and insulator ablation issues still need to be addressed before railguns can start to replace conventional weapons. Probably the most successful system was built by the UK's Defence Research Agency at Dundrennan Range in Kirkcudbright, Scotland. This system has now been operational for over 10 years at an associated flight range for internal, intermediate, external and terminal ballistics, and is the holder of several mass and velocity records.

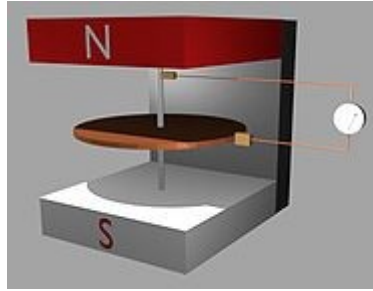
The United States military is funding railgun experiments. At the University of Texas at Austin Institute for Advanced Technology, military railguns capable of delivering tungsten armor piercing bullets with kinetic energies of nine million joules have been developed. Nine mega-joules is enough energy to deliver 2 kg of projectile at 3 km/s - at that velocity a tungsten or other dense metal rod could penetrate a tank.

The United States Naval Surface Warfare Center Dahlgren Division demonstrated an 8 mega-joule rail gun firing 3.2 kilogram (slightly more than 7 pounds) projectiles in October of 2006 as a prototype of a 64 mega-joule weapon to be deployed aboard Navy warships. Such weapons are expected to be powerful enough to do a little more damage than a BGM-109 Tomahawk missile at a fraction of the projectile cost.

Due to the very high muzzle velocity that can be attained with railguns, there is interest in using them to shoot down high-speed missiles.

**A homopolar generator** is a DC electrical generator that is made when a magnetic electrically conductive rotating disk has a different magnetic field passing through it (it can be thought of as slicing through the magnetic field). This creates a voltage and current difference between 2 contact points, one in the center of the disk the other on the outside of the disk. For simplicity one contact point can be considered positive +, and the other contact point can be considered ground or negative (- or 0). In general the 2 contact points are linked together as the armature. It has the same polarity at every point, so that the armature that passes through the magnetic field lines of force continually move in the same direction. The device is electrically symmetrical (bidirectional), and generates continuous direct current. It is also known as a unipolar generator, acyclic generator, disk dynamo, or Faraday disk (Fig.2). Relatively speaking they can source tremendous electric current (10 to 10000 amperes) but at low potential differences (typically 0.5 to 3 volts). This property is due to the fact that the homopolar generator has very low internal resistance.

The device consists of a conducting flywheel rotating in a magnetic field with one electrical contact near the axis and the other near the periphery. It has been used for generating very high currents at low voltages in applications such as welding, electrolysis and railgun research. In pulsed energy applications, the angular momentum of the rotor is used to store energy over a long period and then release it in a short time.



**Fig.2.** Basic Faraday disc generator

One of the larger homopolar generators that was produced by Parker Kinetic Designs via the collaboration of Richard Marshall, William Weldon, and Herb Woodson. Parker Kinetic Designs have produced devices which can produce five megaamperes. Another large homopolar generator was built by Sir Mark Oliphant at the Research School of Physical Sciences and Engineering, Australian National University. It produced 500 megajoules and was used as an extremely high-current source for experimentation from 1962 until it was disassembled in 1986. Oliphant's construction was capable of supplying currents of up to 2 megaamperes.

### **Magnets.**

**Neodymium magnets** are very strong relative to their mass, but are also mechanically fragile. High-temperature grades will operate at up to 200 and even 230°C but their strength is only marginally greater than that of a samarium-cobalt magnet. As of 2008 neodymium magnets cost about \$44/kg, \$1.40 per BHmax.

Most neodymium magnets are anisotropic, and hence can only be magnetised along one direction although B10N material is isotropic. During manufacture fields of 30-40 kOe are required to saturate the material. Neodymium magnets have a coercivity (required demagnetisation field from saturation) of about 10,000-12,000 Oersted. Neodymium magnets (or “neo” as they are known in the industry) are graded in strength from N24 to the strongest, N55. The theoretical limit for neodymium magnets is grade N64. The number after the N represents the magnetic energy product, in megagauss-oersteds (MGOe) ( $1 \text{ MG}\cdot\text{Oe} = 7,958 \cdot 10^3 \text{ T}\cdot\text{A/m} = 7,958 \text{ kJ/m}^3$ ). N48 has a remnant static magnetic field of 1.38 teslas and an  $H$  (magnetic field intensity) of 13,800 Oersteds (1.098 MA/m). By volume one requires about 18 times as much ceramic magnetic material for the equivalent magnet lifting strength, and about 3 to 5 times as much for the equivalent dipole moment. A neodymium magnet can hold up to 1300 times its own weight.

The neodymium magnet industry is continually working to push the maximum energy product (strength) closer to the theoretical maximum of 64 MGOe. Scientists are also working hard to improve the maximum operating temperature for any given strength.

*Physical and mechanical properties:* Electrical resistivity 160  $\mu\text{-ohm}\cdot\text{cm}/\text{cm}^2$ ; Density 7.4-7.5  $\text{g}/\text{cm}^3$ ; Bending strength 24  $\text{kg}/\text{mm}^2$ ; Compressive strength 80  $\text{kg}/\text{mm}^2$ ; Young's modulus  $1.7 \times 10^4 \text{ kg}/\text{mm}^2$ ; Thermal conductivity 7.7  $\text{kcal}/\text{m}\cdot\text{h}\cdot^\circ\text{C}$ ; Vickers hardness 500 – 600.

**Samarium-cobalt** magnets are primarily composed of samarium and cobalt. They have been available since the early 1970s. This type of rare-earth magnet is very powerful, however they are brittle and prone to cracking and chipping. Samarium-cobalt magnets have Maximum Energy Products (BHmax) that range from 16 Mega-Gauss Oersteds (MGOe) to 32 MGOe, their theoretical limit is 34 MGOe. Samarium Cobalt magnets are available in two "series", namely Series 1:5 and Series 2:17.

*Material properties:* Density: 8.4  $\text{g}/\text{cm}^3$  ; Electrical Resistivity  $0.8 \times 10^{-4} \Omega\cdot\text{cm}$ ; Coefficient of thermal expansion (perpendicular to axis): 12.5  $\mu\text{m}/(\text{m}\cdot\text{K})$  .

**Alnico** is an acronym referring to alloys which are composed primarily of aluminium (symbol Al), nickel (symbol Ni) and cobalt (symbol Co), hence *al-ni-co*, with the addition of iron, copper, and sometimes titanium, typically 8–12% Al, 15–26% Ni, 5–24% Co, up to 6% Cu, up to 1% Ti, and the

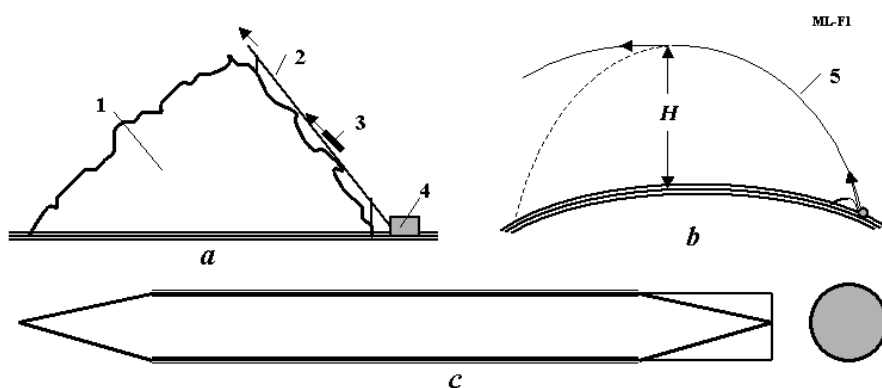
balance is Fe. The primary use of alnico alloys is magnet applications.

Alnico remanence ( $B_r$ ) may exceed 12,000 G (1.2 T), its coercion force ( $H_c$ ) can be up to 1000 oersted (80 kA/m), its energy product ( $(BH)_{\max}$ ) can be up to 5.5 MG·Oe (44 T·A/m)—this means alnico can produce high magnetic flux in closed magnetic circuit, but has relatively small resistance against demagnetization.

As of 2008, Alnico magnets cost about \$20/pound or \$4.30/ $BH_{\max}$ .

## 2. Description of Suggested Launcher

**Brief Description.** The installation includes (see notations in Figs. 3, 4): a gun, two electric rails 2, a space apparatus 3, and a drive station 4 (fig.3). The drive station includes: a homopolar electric generator 1 (fig. 4), a variable reducer 3, a fly-wheel energy storage 5, an engine 6, and master drive clutches 2, 4, 6.



**Fig.3.** Magnetic Launcher. (a) Side view; (b) Trajectory of space apparatus; (c) Hypersonic apparatus. *Notations:* 1 – hill (side view); 2 – railing; 3 – shell; 4 – drive station; 5 – space trajectory.

The system works in the following way:

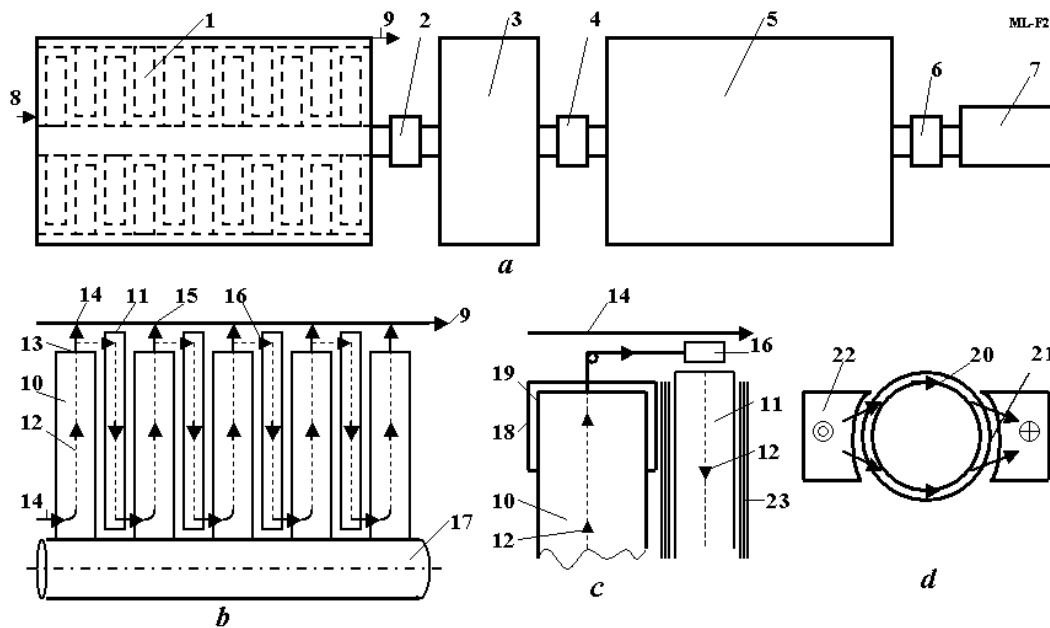
The engine 7 accelerates the flywheel 5 to maximum safe rotation speed. At launch time, the fly wheel connects through the variable reducer 3 to the homopolar electric generator 1 which produces a high-amperage current. The gas gun takes a shot and accelerates the space apparatus “c” (fig.3) up to the speed of 1500 – 2000 m/s. The apparatus leaves the gun and gains further motion on the rails 2 (fig. 3, fig. 4d) where its body turns on the heavy electric current from the electric generator. The magnetic force of the electric rails accelerates the space apparatus up to speeds of 8000 m/s. (or more) The initial acceleration with a gas gun can decrease the size and cost of the installation when the final speed is not high. The gas gun cannot produce a projectile speed of more than about 2000 m/s. The railgun does not have this limit, but produces some engineering problems such as the required short (pulsed) gigantic surge of electric power, sliding contacts for some millions of amperes current, storage of energy, etc.

The current condensers have a small electric capacity 0.002 MJ/kg ([2], p.465). We would need about  $10^{10}$  J energy and 5000 tons of these expensive condensers. The fly-wheels made of cheap artificial fiber have capacity about 0.5 MJ/kg ([2], p.464). The need mass of fly-wheel is decreased to a relatively small 25 – 30 tons. The unit mass of a fly-wheel is significantly cheaper then unit mass of the electric condenser.

The offered design of the magnetic launcher has many innovations which help to overcome the obstacles afforded by a conventional railgun. Itemizing some of them:

1. Fly-wheels from artificial fiber.
2. Small variable reducer with smooth change of turns and high variable rate.

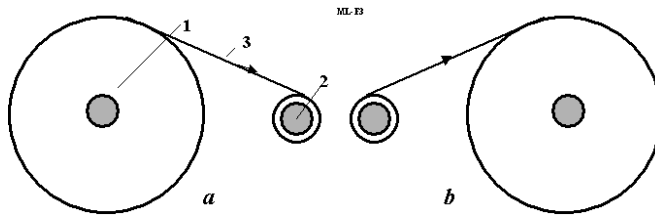
3. Multi-stage monopolar electric generator having capacity of producing millions of amperes and a variable high voltage during a short time.
4. Sliding mercury (gallium) contact having high pass capacity.
5. Double switch having high capacity and short time switching.
6. Special design of projectile (conductor ring) having permanent contact with electric rail.
7. Thin (lead) film on projectile contacts that improve contact of projectile body and the conductor rail.
8. Homopolar generator has magnets inserted into a disk (wheel) form. That significantly simplifies the electric generator.
9. The rails and electric generator can have internal water-cooling.
10. The generator can return rotation energy back to a flywheel after shooting, while rails can return the electromagnetic energy to installation. That way a part of shot energy may be returned. This increases the coefficient of efficiency of the launch installation.



**Fig.3.** Drive station. *(a)* Main components of drive station; *(b)* Rotors and connection disks (wheels); *(c)* Association of rotor and connection disk; *(d)* Association of shell and electric rails (plough or sled). *Notations:* 1 – Electric homopolar generator; 2, 4, 6 – master drive clutch; 3 – variable reducer; 5 – fly-wheel; 7 – engine; 8 – enter of electric line; 9 – exit of electric line; 10 – disk (wheel) of rotor (rigid attachment to shaft 17); 11 – motionless conductor (rigid attachment to stator); 12 – electric current; 13 – sliding contact; 14, 15 – exit conductor; 16 – double switch from electric line 14 to conductor 11; 18 – sliding contact; 19 – mercury; 20 – electric ring; 21 – thin film; 22 – electric rail.

The fly-wheel has a disadvantage in that it decreases its' turning speed when one spends its energy. The prospective space apparatus and space launcher needs, on the contrary, an increase of voltage for accelerating the payload. The homopolar generator really would like to increase the number of revolutions thus increasing the voltage. The offered variable reducer approaches this ideal, keeping constant or even increasing the speed of rotation of the electric generator. In addition, the multi-stage electric generator can additionally increase its' voltage by chaining (concatenation of turning on in series mode) its stages or sections.

The sketch of the variable reducer is shown in fig.5. The tape (inertial transfer roll) 3 rotates from shaft 1 (electric generator) to shaft 2 (fly-wheel). In starting position the tape (roll) diameter  $d_1$  of shaft 1 is big while the tape (roll) diameter  $d_2$  of the fly-wheel is small and rotation speed of electric generator is small. During the rotation, the tape (roll) diameter of shaft 1 decreases, while the corresponding diameter around shaft 2 increases and the rotation speed of the electric generator increases (assuming a correct design of the reducer). The total change of the rotation speed is  $(d_1/d_2)^2$ . For example, if  $d_1/d_2 = 7$ , the total change of rotary speed is 49. This way the rotation speed of the electric generator either increases or stays constant in spite of the fact that the rotary speed of the flywheel is decreasing. The multi-stage electric generator achieves the additional increasing of voltage. Its' sections turn on in series.



**Fig.5.** Variable reducer. (a) Start position; (b) final position. Notations: 1 – shift of electric generator; 2 – shift of fly-wheel; 3 – tape (inertial transfer roll).

### Theory and computations. Project.

Below is advanced theory of the magnetic launcher and a computation of a sample project.

Let us take the mass of a space apparatus payload  $m = 150$  kg, speed after gas gun  $V_o = 1500$  m/s and final speed  $V = 8000$  m/s.

1. *Estimation of gas gun and magnet accelerator.* Let us take the length of gun barrel  $l = 15$  m. Then average projectile acceleration is

$$a = \frac{V_o^2}{2l} = \frac{(1500)^2}{2 \cdot 15} = 7.5 \cdot 10^4 \text{ m/s}^2. \quad (1)$$

Let us take this acceleration as constant value for main rail magnet acceleration. Then time  $t$ , length  $L$  of magnetic acceleration, force  $F$ , and energy  $A$  are

$$V = V_o + at; \quad t = (V - V_o) / a = 8.67 \cdot 10^{-2} \text{ s}, \quad L = V_o t + at^2 / 2 = 412 \text{ m}, \quad (2)$$

$$F = ma = 1.12 \cdot 10^7 \text{ N}, \quad A = mV^2 / 2 = 4.8 \cdot 10^9 \text{ J}$$

2. *Requested electric current and maximal opposed electric intensity from space ship acceleration.*

Let us take the distance between rail  $d = 0.2$ m and semi-thickness of rail  $a_1 = 0.05$ m.

The request electric currency  $i$  and maximum opposed electric intension  $E_m$  are

$$i = \left( \frac{\pi F}{\mu_o} \left( \ln \left| \frac{d - a_1}{a_1} \right| \right)^{-1} \right)^{0.5} = 5 \cdot 10^6 \text{ A}, \quad E_m = \frac{\mu_o}{\pi} i V \ln \left| \frac{d - a_1}{a_1} \right| = 17.6 \cdot 10^3 \text{ V}, \quad (3)$$

where  $\mu_o = 4\pi \times 10^{-7}$  – magnet constant.

3. *Resistance of electric rails.* Let us consider a copper rail with safety limit of temperature increase  $\Delta T = 200$ K. The copper has electric resistance  $\rho = 1.7 \times 10^{-8}$   $\Omega$ .m specific density  $\gamma = 8430$  kg/m<sup>3</sup>, heat capacity  $c_p = 90$  J/kg.K. From the equation of heat balance we have need of the cross-section area  $s$  of rail:

$$s = i \sqrt{\frac{\rho t}{c_p \gamma \Delta T}} = 0.0158 \text{ m}^2, \quad r = \rho \frac{2L}{s} = 9.34 \cdot 10^{-4} \Omega, \quad U_r = ir = 4670 \text{ V}. \quad (4)$$

where  $r$  is electric resistance, Ohm;  $U_r$  maximal electric intensity from Ohm resistance of rails, V.

4. *Maximal request voltage  $U_m$ , average electric power  $N$  and electric energy  $A$  are:*

$$U_m = E_m + U_r = 22.3 \cdot 10^3 \text{ V}, \quad N = 0.5iU_m = 5.5 \cdot 10^{10} \text{ W}, \quad A = Nt = 4.71 \cdot 10^9 \text{ J}, \quad (5)$$

The maximal electric power is two times more than 11 MkW. In our computation we neglect the loss of voltage in the generator.

5. *Rotor of the electric generator.* Radius of rotor the  $n$  ( $n = 20$ ) studies electric generator  $R$  for magnetic intensity  $B = 1.2 \text{ T}$ , and maximal the rotary speed  $V_r = 600 \text{ m/s}$  is

$$R = \frac{2U_m}{nBV_r} = 3.1 \text{ m}. \quad (6)$$

If one disk of rotor has mass of 200 kg, the total mass of rotor will be  $m_r = 200 \times 20 = 4000 \text{ kg}$ .

6. *Fly-wheel.* Assume the fly-wheel made from artificial fiber having a safe tensile stress  $\sigma = 100 \text{ kg/mm}^2 = 10^9 \text{ N/m}^2$ , specific density  $\gamma = 2000 \text{ kg/m}^3$ . Then a safe rotary speed  $V_f = (\sigma/\gamma)^{0.5} = 710 \text{ m/s}$  and mass  $M$  of fly-wheel is

$$M = 2A/V_f^2 + m_r = 20,000 + 4,000 = 24,000 \approx 25,000 \text{ kg} = 25 \text{ tons}. \quad (7)$$

We added 1 ton for friction in fly-wheel, reducer, generator, and loss in connection wire from electric generator to the rail. The maximal number of angular velocity is  $\omega = V_f/R = 229 \text{ radian/s} = 36.5 \text{ revolution/s}$ .

7. *Coefficient efficiency of rails is  $\eta_1 = E_m/U_m = 0.79$ .*

8. *Inductance  $L_i$  and energy  $W$  of a rail magnetic field are*

$$L_i = \frac{\mu_o}{2} \left( 0.5 + \ln \frac{d}{a} \right) L = 3.45 \cdot 10^{-4} \text{ H}, \quad W = \frac{iL_i}{2} = 4.33 \cdot 10^9 \text{ J}. \quad (8)$$

9. *Maximal repulsion force of rails is*

$$F_1 = \frac{\mu_o}{2\pi d} i^2 = 2.5 \cdot 10^7 \text{ N/m} = 2.5 \cdot 10^3 \text{ tons/m}. \quad (9)$$

This will merit your attention – this force is high and rails need in strong connection.

10. *Loss of launched apparatus speed in Earth's atmosphere is about 100 m/s (see [1], pp.48-39, 135).*

11. *Additional required fuel mass to achieve delta-v at top of the trajectory (Fig.3) for circularization of the Earth orbit. (Typically a few hundred meters a second required velocity change.)*

If rail angle is  $\theta = 35^\circ$  degrees, the request orbit altitude is  $H = 4000 \text{ km}$  and a solid rocket apparatus engine has impulse  $w = 2000 \text{ m/s}$ , then request relative fuel mass is 0.2 (see [1], pp. 136-137).

If  $\theta = 40 - 45^\circ$ ,  $H = 400 \text{ km}$ ,  $w = 2280 - 3410 \text{ m/s}$  the request relative fuel is about 0.1.

This means: from total mass of apparatus  $m = 150 \text{ kg}$  the payload may be 100 -- 115 kg, the fuel 15 - 30 kg and the projectile body 15 - 35 kg.

12. *Cost of launch one kg of payload.* Assume the conventional turbo engine is used for moving the fly-wheel. Let us take the coefficient of efficiency the engine  $\eta_1 = 0.3$  and the coefficient of efficiency of our launcher  $\eta_2 = 0.6$ . Then the requested amount of a fuel (gas, benzene) for one launch is

$$m_f = \frac{A}{\eta_1 \eta_2 q} = 623 \text{ kg}, \quad (10)$$

where  $A = 4.71 \times 10^9 \text{ J}$  is energy (see (5)),  $q = 42 \times 10^6 \text{ J/kg}$  is heat capacity of fuel.



If cost of fuel is  $c = \$0.5/\text{kg}$  (end of 2008) and payload is 100 kg, the fuel cost per one kg is

$$C_f = c \cdot m_f / m_p = \$3.11/\text{kg} . \quad (11)$$

If frequency of launches is  $t = 30$  min, the need power of engine is  $N_e = A/\eta_2 t = 4.36 \times 10^3$  kW. That is power of a middle aviation turbo engine.

Let us assume the cost of magnetic launcher is 50 millions of dollars, lifetime of installation is 10 year and mountain is \$2 millions of dollars per year. The launcher works the 350 days and launches 100 kg payload every 30 min (This means about 5000kg/day and 1750 tons/year). Then additional cost from installation is  $C_i = \$2.86/\text{kg}$  and total cost is

$$C = C_f + C_i \approx \$6/\text{kg}. \quad (12)$$

Compare this to the current cost of launching 1 kg of payload from \$2500- \$50000.

## Conclusion

The research shows the magnetic launcher can be built by the current technology. This significantly (by a thousand times) decreases the cost of space launches. Unfortunately, if we want to use the short rail way (412 m), any launcher request a big acceleration about  $7.5 \cdot 10^3$  g and may be used only for unmanned, hardened payload. If we want design the manned launcher the rail way must be 1100 km for acceleration  $a = 3g$  (untrained passengers) and about 500 km ( $a = 6g$ ) for trained cosmonauts.

Our design is not optimal. For example, the computation shows, if we increase our rail track only by 15 m, we do not need gas gun initial acceleration. That significantly decreases the cost of installation and simplifies its construction.

The reader can recalculate the installation for his own scenarios.

## References

(The reader may find some of these articles, in the WEB of Cornel University <http://arxiv.org> , search term "Bolonkin" and at the author's web page: <http://Bolonkin.narod.ru/p65.htm>)

1. Bolonkin A.A., Non-Rocket Space Launch and Flight, Elsevier, 2006, 488 pgs.
2. Bolonkin A.A., New Concepts, Ideas and Innovations in Aerospace, Technology and Human Sciences, NOVA, 2008, 502 pgs.
3. Bolonkin A.A., Cathcart R.B., Macro-Projects: Environment and Technology, NOVA, 2008, 537 pgs.
4. A. Bolonkin, M. Krinker., Magnetic Propeller for Uniform Magnetic Field Levitation <http://arxiv.org/ftp/arxiv/papers/0807/0807.1948.pdf> (12 July, 2008).
5. A. Bolonkin, M. Krinker. Magnetic Propeller. Article presented as paper AIAA-2008-4610 to 44th Joint Propulsion Conference, 20-24 July, 2008, Hartford, CT,
6. A. Bolonkin, M. Krinker. , Magnetic Propeller for Uniform Magnetic Field. (Ch.13 . in the book "Macro-Projects: Environment and Technology", NOVA, 2009)
7. A.A. Bolonkin, Earth Accelerator for Space Ships and Missiles, *JBIS*, Vol. 56, No. 11/12, 2003, pp. 394–404.
8. A.A. Bolonkin, "Space Cable Launchers", Paper No. 8057 presented at the Symposium "The Next 100 years", Dayton, OH, USA, 14-17 July, 2003.
9. A.A. Bolonkin, Centrifugal Space Launcher, Presented as paper AIAA-2005-4035 at the 41<sup>st</sup> Propulsion Conference, 10-12 July 2005, Tucson, AZ, USA.
10. A.A. Bolonkin, Electrostatic Linear Engine and Cable Space AB Launcher, Paper AIAA-2006-5229 for 42 Joint Propulsion Conference, Sacramento, USA, 9-12 July, 2006. See also AEAT Vol.78, No.2006, pp. 502-508.

11. M. Minovich, "Electromagnetic Transportation System for Manned Space Travel", US Patent #4,795,113, January 3 1989.
12. D.E. Koell, *Handbook of Cost Engineering*, TCS, Germany, 2000.
13. *Wikipedia*. Some background material in this article is gathered from Wikipedia under the Creative Commons license. <http://wikipedia.org> .



## Chapter 9

# Lower Current and Plasma Magnetic Railguns

### Abstract

It is well-known that the magnetic railgun theoretically allows a very high 'exhaust velocity' of projectile. The USA and England have tried to research and develop working railgun installations. However the researchers had considerable problems in testing. The railgun requests very high (millions of amperes,) electric current (but low voltage). As result the rails and contacts burn and melt. The railgun can make only ONE shot between repairs, cannot shoot a big and high speed projectile, and has low efficiency.

The heat and inductive losses of railgun depend upon the square of electric current. If we decrease electric current by ten times, we decrease the losses by one hundred times. But the current design of railgun does not allow decreasing the current because that leads to loss --also by the square-- of electromotive force.

In this article the author describes new ideas, theory and computations for design of new magnetic lower cost accelerators for railgun projectiles and space apparatus. This design decreases the requested electric current (and loss) in hundreds times. This design requires a similar increase in voltage (because the energy for acceleration is the same). But no super heating, burn and melting rails, contacts, or big losses. The power and mass of projectiles and space apparatus can be increased in a lot of times. High voltage current does not require special low voltage equipment and may be used directly from the electric stations, saving huge amounts of money.

Author also suggests a new plasma magnetic accelerator, which has no traditional sliding mechanical contacts, significantly decreases the mass of electrical contacts and increases the useful mass of projectile in comparison with a conventional railgun.

Important advantages of the offered design are the lower (up to some tens of times) usage of electric current of high voltage and a very high efficiency coefficient closeto 95% (compare with efficiency of the current railgun which equals 20 – 40%). The suggested accelerators may be produced by present technology.

The projects of railguns are computed herein.

-----  
**Key words:** railgun, space launcher, low current magnetic space launcher, magnetic accelerator, plasma magnetic launcher, AB-Accelerator.

## 1. Introduction

At present, rockets are used to carry people and payloads into space, or to deliver bombs over long distances. This method is very expensive, and requires a well-developed industry, high technology, expensive fuel, and complex devices.

Other than rockets, methods to reach altitudes and speeds of interest (even prospectively) are the space elevator, the hypersonic tube air rocket, cable space accelerator, circle launcher and space keeper, centrifugal launcher [1-9], electrostatic liner accelerator [10]. Several new non-rockets methods were also proposed by the author at the World Space Congress-2002, Houston, USA, 10 – 19 October 2002. Some new ideas are in the works [11]-[13].

The space elevator requires very strong nanotubes, as well as rockets and high technology for the initial development. The tube air rocket and non-rocket systems require more detailed research. The

electromagnetic transport system, suggested by Minovich (US Patent, 4,795,113, 3 January, 1989)[20], is not realistic at the present time. It requires a vacuum underground tunnel 1530 kilometers long located at a depth of 40 kilometers. The project requires an active cooling system (because the temperature is very high at this depth), a complex power electromagnetic system, and a huge impulse of energy that is greater than the energy of all the electric generating stations on Earth.

This article suggests a very simple and inexpensive methods and installations for launching into space.

**Railgun.** Scientists use a railgun for high acceleration of a small conducting body. A railgun is a form of gun that converts electrical energy (rather than the more conventional chemical energy from an explosive propellant) into projectile kinetic energy. It is not to be confused with a coilgun (Gauss gun). Rail guns use magnetic force to drive a projectile. Unlike gas pressure guns, rail guns are not limited by the speed of sound in a compressed gas, so they are capable of accelerating projectiles to extremely high speeds (many kilometers per second).

A wire carrying an electrical current, when in a magnetic field, experiences a force perpendicular to the direction of the current and the direction of the magnetic field.

A railgun consists of two parallel metal rails (hence the name) connected to an electrical power supply. When a conductive projectile is inserted between the rails (from the end connected to the power supply), it completes the circuit. Electrical current runs from the positive terminal of the power supply up the positive rail, across the projectile, and down the negative rail, back to the power supply (Fig.1).

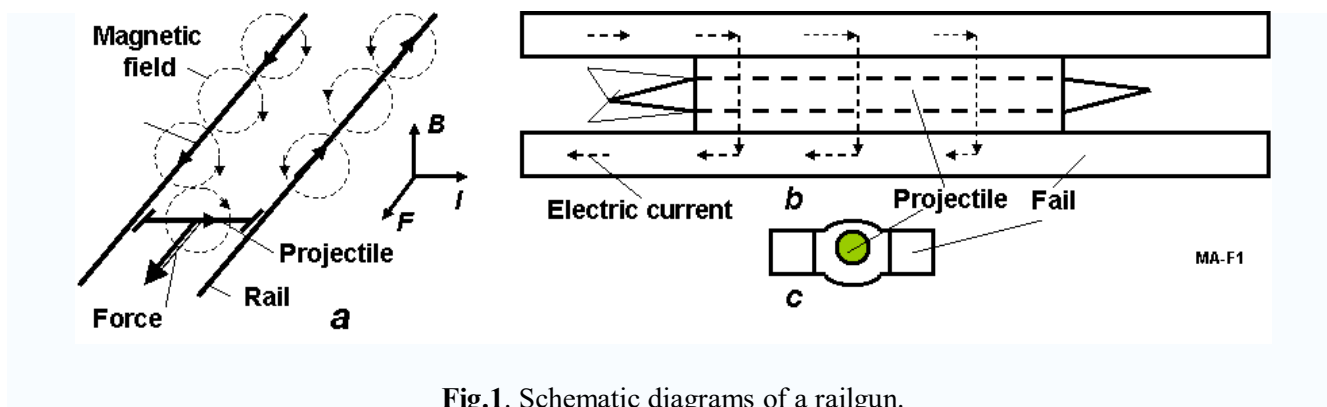
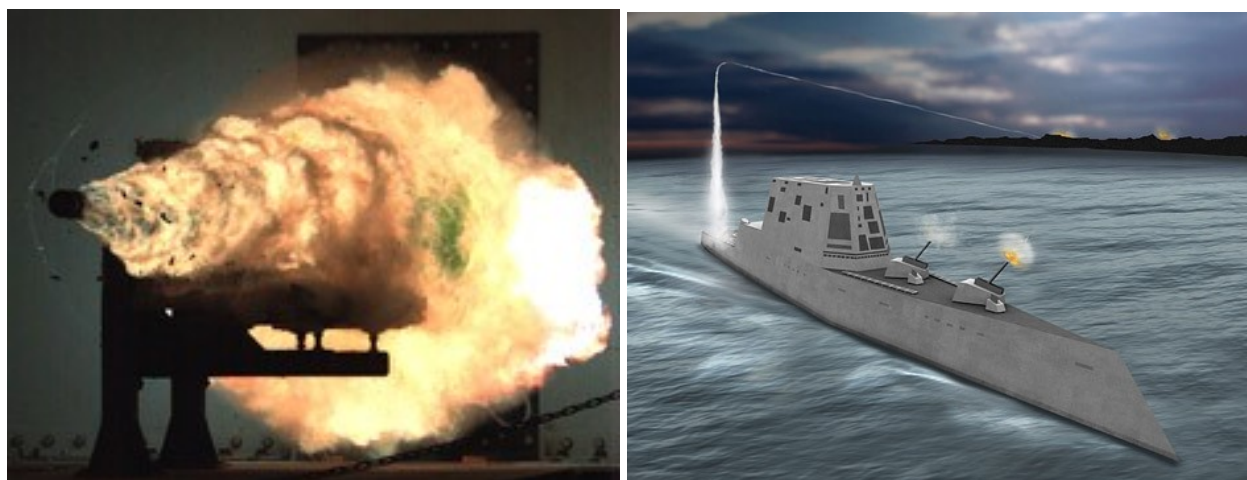


Fig.1. Schematic diagrams of a railgun.

This flow of current makes the railgun act like an electromagnet, creating a powerful magnetic field in the region of the rails up to the position of the projectile. In accordance with the right-hand rule, the created magnetic field circulates around each conductor. Since the current flows in opposite direction along each rail, the net magnetic field between the rails ( $B$ ) is directed vertically. In combination with the current ( $I$ ) flowing across the projectile, this produces a Lorentz force which accelerates the projectile along the rails. The projectile slides up the rails away from the end with the power supply.

If a very large power supply providing a million amperes or so of current is used, then the force on the projectile will be tremendous, and by the time it leaves the ends of the rails it can be travelling at many kilometres per second. 20 kilometers per second has been achieved with small projectiles explosively injected into the railgun. Although these speeds are theoretically possible, the heat generated from the propulsion of the object is enough to rapidly erode the rails. Such a railgun would require frequent replacement of the rails, or use a heat resistant material that would be conductive enough to produce the same effect (fig.2, left). Please notice the gigantic cloud of plasma behind the projectile. That is the result of an electric arc between the contacts. About 70 – 80% of electric energy is lost uselessly.



**Fig.2.** (left) Naval Surface Warfare Center test firing in January 2008, leaving a plume of plasma behind the projectile; (right) the future military ship used the railguns.

The need for strong conductive materials with which to build the rails and projectiles; the rails need to survive the violence of an accelerating projectile, and heating due to the large currents and friction involved acts against the longevity of the system. The force exerted on the rails consists of a recoil force - equal and opposite to the force propelling the projectile, but along the length of the rails (which is their strongest axis) - and a sideways force caused by the rails being pushed by the magnetic field, just as the projectile is. The rails need to survive this without bending, and thus must be very securely mounted.

The power supply must be able to deliver large currents, with both capacitors and compulsators being common.

The rails need to withstand enormous repulsive forces during firing, and these forces will tend to push them apart and away from the projectile. As rail/projectile clearances increase, electrical arcing develops, which causes rapid vaporization and extensive damage to the rail surfaces and the insulator surfaces. This limits most research railguns to one shot per service interval.

Some have speculated that there are fundamental limits to the exit velocity due to the inductance of the system, and particularly of the rails; but United States government has made significant progress in railgun design and has recently floated designs of a railgun that would be used on a naval vessel. The designs for the naval vessels, however, are limited by their required power usages for the magnets in the rail guns. This level of power is currently unattainable on a ship and reduces the usefulness of the concept for military purposes.

Massive amounts of heat are created by the electricity flowing through the rails, as well as the friction of the projectile leaving the device. This leads to three main problems: melting of equipment, safety of personnel, and detection by enemy forces. As briefly discussed above, the stresses involved in firing this sort of device require an extremely heat-resistant material. Otherwise the rails, barrel, and all equipment attached would melt or be irreparably damaged. Current railguns are not sufficiently powerful to create enough heat to damage anything; however the military is pushing for more and more powerful prototypes. The immense heat released in firing a railgun could potentially injure or even kill bystanders. The heat released would not only be dangerous, but easily detectable. While not visible to the naked eye, the heat signature would be unmistakable to infrared detectors. All of these problems can be solved by the invention of an effective cooling method.

Railguns are being pursued as weapons with projectiles that do not contain explosives, but are given extremely high velocities: 3500 m/s (11,500 ft/s) or more (for comparison, the M16 rifle has a muzzle



speed of 930 m/s, or 3,000 ft/s), which would make their kinetic energy equal or superior to the energy yield of an explosive-filled shell of greater mass. This would allow more ammunition to be carried and eliminate the hazards of carrying explosives in a tank or naval weapons platform. Also, by firing at higher velocities railguns have greater range, less bullet drop and less wind drift, bypassing the inherent cost and physical limitations of conventional firearms - *"the limits of gas expansion prohibit launching an unassisted projectile to velocities greater than about 1.5 km/s and ranges of more than 50 miles [80 km] from a practical conventional gun system."*

If it is ever possible to apply the technology as a rapid-fire automatic weapon, a railgun would have further advantages in increased rate of fire. The feed mechanisms of a conventional firearm must move to accommodate the propellant charge as well as the ammunition round, while a railgun would only need to accommodate the projectile. Furthermore, a railgun would not have to extract a spent cartridge case from the breech, meaning that a fresh round could be cycled almost immediately after the previous round has been shot.

**Tests of Railgun.** Full-scale models have been built and fired, including a very successful 90 mm bore, 9 MJ (6.6 million foot-pounds) kinetic energy gun developed by DARPA, but they all suffer from extreme rail damage and need to be serviced after every shot. Rail and insulator ablation issues still need to be addressed before railguns can start to replace conventional weapons. Probably the most successful system was built by the UK's Defence Research Agency at Dundrennan Range in Kirkcudbright, Scotland. This system has now been operational for over 10 years at an associated flight range for internal, intermediate, external and terminal ballistics, and is the holder of several mass and velocity records.

The United States military is funding railgun experiments. At the University of Texas at Austin Institute for Advanced Technology, military railguns capable of delivering tungsten armor piercing bullets with kinetic energies of nine million joules have been developed. Nine mega-joules is enough energy to deliver 2 kg of projectile at 3 km/s - at that velocity of a tungsten or other dense metal rod could penetrate a tank.

The United States Naval Surface Warfare Center Dahlgren Division demonstrated an 8 mega-joule rail gun firing 3.2 kilogram (slightly more than 7 pounds) projectiles in October of 2006 as a prototype of a 64 mega-joule weapon to be deployed aboard Navy warships. Such weapons are expected to be powerful enough to do a little more damage than a BGM-109 Tomahawk missile at a fraction of the projectile cost.

Due to the very high muzzle velocity that can be attained with railguns, there is interest in using them to shoot down high-speed missiles.

## Description of Innovations and Problems in AB-Launchers

### Low current multi-loop railguns

**Description of multi-loop Launchers .** The conventional magnetic accelerator (railgun) is shown in fig.1. That contains two the conductive rails connected by a **sliding** jumper. Electric current produces the magnetic field and magnetic force. The jumper accepts the magnetic force and accelerates the projectile. Main defects of conventional rail gun: The rail gun requires a gigantic current (millions of amperes) of low voltage, rails have large electric resistance, strongly heating up, contacts burn, installation is damaged and requires repair after every shot. The energy charge is high (small coefficient of efficiency). You see the gigantic plasma column behind the small projectile in fig.2 (left)). The repulsive force between rails is gigantic (thousands of tons) and installation is thus heavy and expensive if it is to survive a single shot.

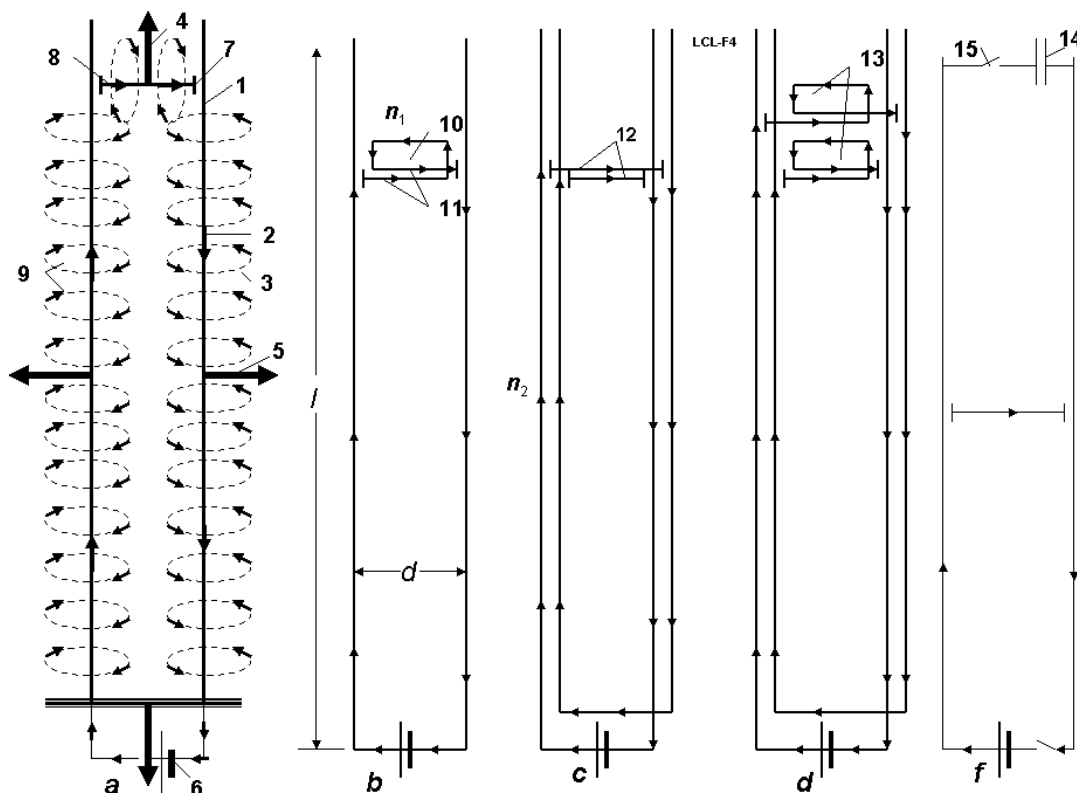
*Description..* The fig.3a shows the principal scheme of the conventional railgun. The installation of fig.3a includes the long vertical wire 2, moved jumper 8, sliding contacts 7 and electric source 6. The



electric current produces the magnetic field 3 (magnetic column), the magnetic field creates the vertical 4 and horizontal 5 forces. Vertical force 4 accelerates the useful load at top of the installation.

This design is used in a rail gun [6] but the author made many innovations that allow applying these ideas to this new application as the efficient magnetic accelerators. Some of them are listed below.

**Innovations.** The figs.3b-3f show schemes of the suggested accelerators. The author offers the following innovations having the next advantages:



**Fig. 3.** Conventional and low current launchers. (a) Conventional high current and low voltage railgun; (b) Offered low current launcher with the wire horizontal multi-loops (version 1); (c) Offered low current launcher with the wire vertical multi-loops (version 2); (d) Offered low current launcher with the wire horizontal and vertical multi-loops (version 3); (e) RailGun with condenser. (version 4).

*Notations:* 1 – installation, 2 – vertical wire, 3 – magnetic field from vertical wire; 4 – moved vertical force from jumper; 5 – magnetic force from vertical electric wire, 6 – electric source, 7- sliding contact, 8 – horizontal jumper, 9 - magnetic column, 10 – multi-loop spool, 11, 12 – horizontal force wire connected in one bunch, 13 – force multi-loops spools connected in one spool, 14 – condenser, 15 – electric switch.

1) *Version 1* (fig.3b). The horizontal wire (fig.3a, former sliding jumper 8 of fig.3a) is made in a form of closed-loop spool (fig.3b, #10). The lower part of this spool (fig.3b, #11) located in place of former jumper near the magnetic field of vertical wire (fig.3b). The top part of this spool (fig.3b, #10) located at top – out of the magnetic field of vertical wire 2. As the result the magnetic field of the vertical wire 2 activates only on horizontal wires 11. But now we have here not one wire with current  $i$ , we have  $n$  wires and current  $ni$ . The magnetic force 4 and requested 4 voltage increases by  $n$  times! The force spool 10 can have some hundreds loops and force will be more in same times than in case of fig 3a. For same vertical force the electric current in the vertical connection wires 2 may be decreases in  $n_1 = n$  times, where  $n_1$  is number of horizontal loops. The electric current may be relatively small (only some tens of thousands of amperes, not millions) and of the high voltage. The

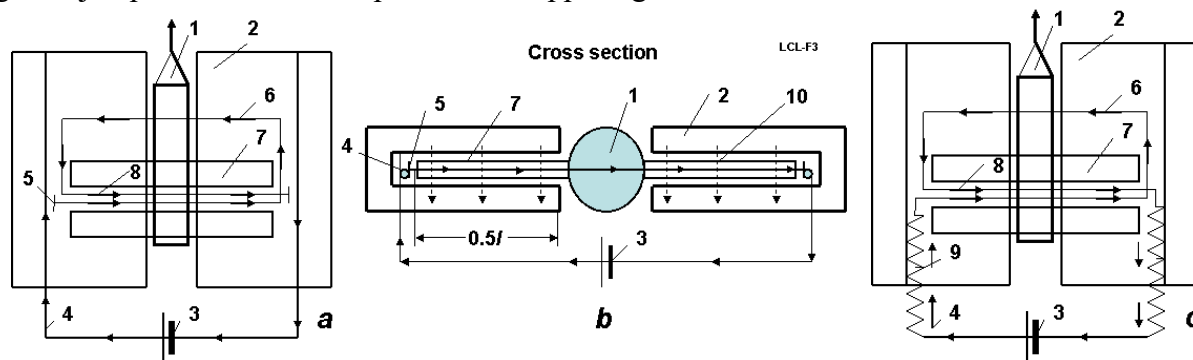
- request vertical wire may be relatively thin. The heating, contact and inductive losses decrease in  $n_1$  times, where  $n_1$  is number of horizontal loops. The number of contacts  $N=2$  is same (not increases).
- 2) *Version 2* (fig.3c). Installation contains the vertical closed loops  $n_2$ . For same vertical force the electric current decreases in  $n_2$  times, the voltage increases by  $n_2$  times. The number of contacts  $N$  also increases by  $n_2$  times. But heating of every contact decreases by  $n_2^2$ . Common electric heat, contact and inductive losses decrease by  $n_2$  times.
  - 3) *Version 3* (fig.3d). That is composition of versions 1 and 2. For same vertical force the electric current decreases by  $n_1n_2$  times. The number of contacts  $N$  increases in  $n_2$  times. But heating of every contact decreases by  $n_1n_2$ . Common electric heat, contact and inductive losses decrease in  $n_1n_2$  times.
  - 4) *Version 4* (fig.3f). The main electric loss in conventional railgun is an inductive loss, which produces a gigantic inductive current and plasma flash. This loss may be significantly decreases by switching the condenser in the end of the projectile track.

The main innovation is a top loop 10 (right angle spool [1]), which increases the number of horizontal wires 11 (multi-loops), magnetic intensity in area under 11 and lift force 4. We can make a lot of loops up to some hundreds and increase the lift force by hundreds of times. For a given lift force we can decrease the required current in many times and decreases the mass of the source wire 2. That does not necessarily mean that we decrease the required electric energy (power) because the new installation needs a higher voltage.

### Multi-loop Railguns with permanent magnets

Main function of the vertical wire 2 (fig.3a) creates the magnetic field between wire 2. This field interacts with the magnetic field from a jumper 8 (fig.3a) or the horizontal wires 11 (fig.3b), 12 (fig.3c) and creates the vertical force 4 (fig.3a). For getting enough force requires a high electric current. However, the needed intensity magnetic field we can produce by means of conventional magnets.

This idea explored in multi-loop launcher (accelerator) is offered in fig.4. The launcher has two strong magnets 2 and the multi-loop spool 6. The spool connects through the sliding contacts 5 (fig.4a) to the electric source 3. The design of fig. 4c has the spring wires 9 and not has the sliding contacts 5. The suggested launcher has two the motive magnetic jumpers 7, which significantly increase and close the magnetic lines in the lower part 8 of the force spool 6. The top part of the force spool has not the magnetic jumper 7 and does not produce the opposing motive force.



**Fig.4.** Offered launcher with the permanent magnets. (a) Top view; (b) Cross section; (c) Launcher having the spring wires. *Notations:* 1 – projectile, 2 – magnet, 3 – electric source, 4 – electric current, 5 – sliding contact, 6 – force (jumper) multi-loop spool (top part); 7 – magnetic jumper; 8 – lower part of the multi-loop top (force) electric spool; 9 – the spring electric wire; 10 – magnetic lines;  $0.5l$  is length of a magnetic active zone in one side of wire.

The offered accelerator is closest to the direct current linear electric engine but has four differing important features: It has a spool part of it located out of the strong magnetic lines, the installation has the motive magnetic jumpers, the installation uses constant non-interrupted current, launcher can omit the sliding contacts (fig.4c).

This magnetic accelerator may be suitable for a space launcher having small accelerations.

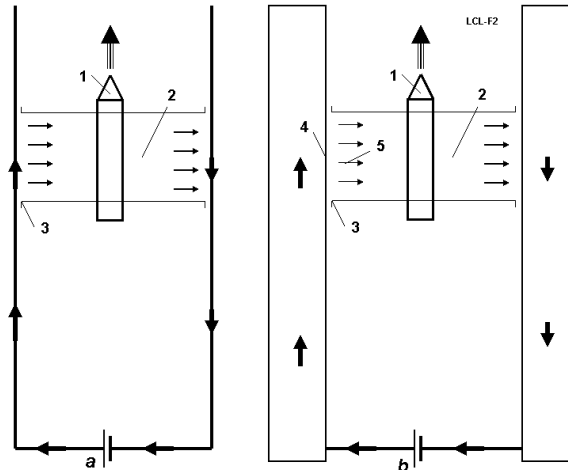
### Plasma magnetic launcher

The jumper 4 (fig.3a), force spools 10, 12, 13 (figs. 3b,c,d), magnetic jumpers 7 (fig.4) can have a big mass and significantly decrease the useful load (in 2 – 3 and more times). For decreasing of this imperfect the author offers the plasma jumper (fig.5). Plasma in jumper has very small mass because plasma has a small density. The plasma can have a high conductivity closed to a metal conductor. But plasma conductor (jumper) can have a big cross-section area and a low electric resistance. Electric conductivity of plasma does not depend from its density. The plasma may be very rarefied. That means the head transfer to walls of a channel may be very small and so not damage them. For example the plasma of Earth radiation belts has a million degrees but spaceman and space apparatus not damage.

The thin wire may be initial initiator of a of plasma cable. Then a plasma conductor supports the big current.

The second advantage of plasma launcher is a gas sliding contact. That cannot burn and is more robust against damage.

The offered plasma cable may be used in other technical fields [2] –[4]. This problem needs further research.



**Fig.5.** Offered plasma launchers. (a) Launcher having conventional vertical wire and plasma jumper; (b) Launcher having vertical and horizontal (jumper) plasma wires. Notations: 1 - projectile, 2 – horizontal plasma jumper, 3 – gas sealing, 4 – conducting tube, 5 – electric current into plasma.

## Theory of Magnetic AB-Launchers

### General Equations

- 1. Conventional Railgun (fig. 3a).** The force, inductive opposed voltage from moved jumper (projectile) and inductive efficiency  $\eta$  may be computed by equations:

$$F = \frac{1}{\pi} \mu_0 i^2 b, \quad b = \ln \left| \frac{d-a}{a} \right|, \quad U = \frac{1}{\pi} \mu_0 i V b, \quad \eta \approx 0.56, \quad (1)$$

where  $F$  is magnetic force, N;  $\mu_0 = 4\pi \cdot 10^{-7}$  – magnetic constant, H/m;  $d$  is distance between centers of vertical wire, m;  $a$  is radius of wire or half thickness of a conductive layer (plate conductor), m;  $b \approx 2 - 10$ ;  $i$  is electric current in the vertical and single horizontal wire, A;  $V$  is projectile (jumper)

speed, m/s;  $U$  is inductive opposed voltage,  $V$  (the speed changes from 0 to  $V_{\max}$  and the voltage changes from 0 to  $U_{\max}$ );  $\eta$  is an inductive efficiency.

**2. Multi-loops launcher, version 1 (fig.3b)** (having only horizontal loops). Proof of magnetic force equation. We use only well-known physical laws (magnetic force on the electric conductor located into magnetic field):

$$dF = n_1 i B dl, \quad B = \mu_0 H, \quad H = \frac{i}{2\pi a}, \quad F = \frac{\mu_0 n_1 i^2}{2\pi} \int_a^{d-a} \frac{1}{l} dl = \frac{\mu_0 n_1 i^2}{2\pi} \ln \left| \frac{d-a}{a} \right|. \quad (2)$$

The force from two vertical wires is

$$F = \frac{\mu_0 n_1 i^2}{\pi} \ln \left| \frac{d-a}{a} \right| = \frac{\mu_0 n_1 i^2 b}{\pi}, \quad U = \frac{1}{\pi} \mu_0 n_1 i V b, \quad \eta = \frac{1}{1 + 0.86/n_1}, \quad (3)$$

where  $n_1$  is number of wire loops at horizontal connection (fig.3b, #11) (in proposed force spool), number of wire loops may be some hundreds;  $\mu_0 = 4\pi \cdot 10^{-7}$  – magnetic constant, H/m;  $i$  is electric current in the vertical and single horizontal wire, A;  $H$  is magnetic intensity in V/m,  $B$  is magnetic intensity in T;  $l$  is acceleration distance, m.

The magnetic field acts only on the lower horizontal part  $l$  of the right-angled force spool because the top horizontal part is far from vertical support wire (at top of installation).

The equation (2) without the spools ( $n_1 = 1$ ) is the well-known equation (1) for the rail gun. The proposed innovation (the force multi-loop spool) increases the force by  $n_1$  times (for same current  $i$ ) but simultaneously increases the required the projectile voltage also by  $n_1$  times if the installation changes its size (for example, the projectile moves thus altering the effective length of the connection).

The spool also creates a strong magnetic field but this field acts only on the spool and produces tensile stress only into the spool. It easily is compensated for by film, fiber or composed material (reinforcement) located in the force spool.

Example: for  $i = 10^4$  A,  $n_1 = 10^3$ ,  $b = 10$  the force is  $F = 4 \cdot 10^5$  N = 40 tons. If  $i = 2 \cdot 10^4$  A, the  $F = 160$  tons. If  $i = 10^5$  A, the  $F = 4000$  tons. Approximately that is the weight of the structure, which can be accelerated or suspended over Earth's surface [5].

Look your attention the inductive loss decreases in  $n_1$  times (last equation in (3)).

For given force  $F$  the required current is

$$i = \left( \frac{\pi F}{\mu_0 n_1 b} \right)^{0.5}, \quad (4)$$

Example: For  $F = 300,000$  N,  $n_1 = 10^3$ ,  $b = 10$  the  $i = 8.7 \cdot 10^3$  A.

Repulsive force between the vertical wires. This force  $F_1$  for a wire length of 1 m is

$$F_1 = \frac{\mu_0 i^2}{2\pi d}, \quad (5)$$

Example: for  $i = 10^4$  A,  $d = 0.1$  m, the force is  $F_1 = 200$  N/m = 20 kgf/m.

Mass of an electric coil. The mass of the electric force top spool (loops) is

$$M_s \approx 3q n_1 d, \quad (6)$$

where  $q$  is mass 1 m wire.

Example: for  $n_1 = 100$ ,  $d = 0.1$  m,  $q \approx 2 \cdot 10^{-2}$  kg/m, the mass one spool is 0.6 kg.

Acceleration time and maximal speed. Trip time  $t$  [s] with constant acceleration equals :

$$t = \sqrt{2S/a_a}, \quad V_{\max} = a_a t, \quad (7)$$

Here  $V_{\max}$  is maximal speed, m/s;  $S$  is acceleration distance, m.

*Inductive efficiency of Railgun and AB-Launcher.* If we neglect the electric heat and friction loss in wire, rails and contacts, the efficiency coefficient of Railgun and AB-Launcher is

$$\eta = \frac{E}{E + E_i}, \quad E = FS, \quad F = \frac{\mu_0 n_1 i^2 b}{\pi}, \quad \eta = \frac{1}{1 + \frac{\pi}{4n_1 b} \left(0.5 + \ln \frac{d}{a}\right)} \approx \frac{1}{1 + \frac{1.1\pi}{4n_1}}. \quad (8)$$

As you see the efficiency coefficient of Railgun depends only from  $n_1$  – number of coils of the force spool. For conventional railgun  $n_1 = 1$  and  $\eta = 0.537$ . If we account the electric and friction loss in wire, rails and contacts, the efficiency coefficient of Railgun will be about  $\eta = 0.2 - 0.3$ . The AB-Accelerator has  $n_1 \approx 100$  and does not have the large electric and friction loss in wire, rails and contacts. Its inductive efficiency coefficient is about 0.95. It is  $\sim 2 - 4$  times more than a conventional railgun or rockets. That is the most efficient among all known space launchers.

*Safe density of the electric current in wire.* The electric current into launcher is very high and electric wire is heated and can melt and burn. Let us to find the safety density of electric current in wire not cooled and cooled by a liquid (for example, evaporate water). Let us take 1 m of wire. The heat energy from the electric current is

$$E = Ri^2 t, \quad R = \rho / s, \quad s = m / \gamma, \quad j = i / s, \quad E = \rho j^2 m t / \gamma, \quad (9)$$

where  $E$  is an electric heat energy in 1 m wire, J/m;  $R$  is electric resistance, Ohm;  $i$  is electric current, A;  $t$  is time, sec;  $\rho$  is the specific electric resistance (for copper  $\rho = 1.75 \cdot 10^{-8} \Omega \cdot \text{m}$ );  $s$  is cross-section area,  $\text{m}^2$ ;  $m$  is mass 1m of wire, kg;  $\gamma$  is the specific wire density,  $\text{kg}/\text{m}^3$ ,  $\gamma = 8930 \text{ kg}/\text{m}^3$  for cooper;  $j$  is current density,  $\text{A}/\text{m}^2$ .

Let us to find the energy (heat) absorbs the wire and the cooling liquid

$$Q = C_{pm} m \Delta T_m + (C_p \Delta T + r) m_l, \quad Q = E, \quad j = \left[ \frac{\gamma [C_{pm} \Delta T + (C_p \Delta T + r) m_l / m]}{\rho t} \right]^{0.5}, \quad (10)$$

where  $Q$  is absorbed energy, J/m;  $C_{pm}$  is thermal capacity of wire (for copper  $C_{pm} = 0.39 \text{ kJ}/\text{kg} \cdot \text{K}$ );  $C_p$  is thermal capacity of a liquid (for water  $C_p = 4.19 \text{ kJ}/\text{kg} \cdot \text{K}$ );  $r$  is heat evaporation (for water  $r = 2260 \text{ kJ}/\text{kg}$ );  $\Delta T_m$  is a safety decrement of a wire temperature, K;  $\Delta T$  is a safety decrement of a liquid temperature, K;  $m_l$  is mass of liquid in 1 m of wire, kg/m;  $\gamma$  is specific density of wire (for copper  $\gamma = 8930 \text{ kg}/\text{m}^3$ ).

**Example:** For copper wire without a cooling liquid for the shot time  $t = 0,003$  sec, safety temperature  $\Delta T_m = 80^\circ\text{K}$ , we has the  $j = 3.26 \cdot 10^3 \text{ A}/\text{mm}^2$ . For copper wire with a water cooling liquid having  $m_l/m = 1$  for safety  $\Delta T_m = \Delta T = 80^\circ\text{K}$ , we has the  $j = 21 \cdot 10^3 \text{ A}/\text{mm}^2$ .

- 3. Multi-loops launcher, version 2 (fig.3c)** (having only vertical loops). The Force and inductive voltage are

$$F = \frac{\mu_0 n i^2 b}{\pi}, \quad U = \frac{1}{\pi} \mu_0 n i V b, \quad \eta = \frac{1}{1 + 0.86/n}, \quad (11)$$

where  $n = n_1 + n_2$  is number horizontal and vertical loops.

- 4. Multi-loops launcher, version 3 (fig.3d)** (having horizontal and vertical loops). The force and inductive voltage are

$$F = \frac{\mu_0 n_1 n_2 i^2 b}{\pi}, \quad U = \frac{1}{\pi} \mu_0 n_1 n_2 i V b, \quad \eta = \frac{1}{1 + 0.86 n_2 / n_1}, \quad (12)$$

where  $n_2$  is number of vertical wire.

- 5. Method turn-off the energy source** during acceleration. It is known that the inductive devices (as railgun) function as storage of electric energy. They accumulate the electric energy when the electric current is increases and return this energy (produce the electric current the same direction when the electric current is decreases). Author offers to turn-off the energy source in during projectile acceleration and uses the accumulated inductive energy in rails for further acceleration of

projectile. This method significantly decreases the final current, plasma flash and increases the gun energy efficiency but unfortunately, radically increases the length of gun barrel.

Let us to estimate the length of barrel from the law of energy. Assume that an induce energy is full transferred to projectile energy. Then (for conventional railgun):

$$E_i = \frac{i^2 L}{2}, \quad L = \frac{\mu_o l}{2} \left( 0.5 + \ln \frac{d}{a} \right), \quad E = \frac{m}{2} (V_1^2 - V_0^2), \quad E_i = E, \quad \frac{V_1}{V_0} = \left[ 1 + \frac{\mu_o i^2 l}{2mV_0^2} \left( 0.5 + \ln \frac{d}{a} \right) \right]^{0.5}, \quad (13)$$

where  $E_i$  is the maximal inductive energy, J;  $E$  is the kinetic energy, J;  $V_1$  is final projectile speed, m/s;  $V_0$  is a projectile speed in moment of turn-off of the current, m/s;  $m$  is mass of projectile, kg;  $l$  is length of barrel in time of a maximal current, m; the other notations are same with previous equations.

The requested increase of gun barrel length is

$$E_1 = F_1 l_1, \quad F_1 = \frac{\mu_o i_1^2 b n_1 n_2}{\pi}, \quad E_i = E_1, \quad i_1 \approx \frac{1}{2} i, \quad \frac{l_1}{l} \approx \frac{\pi}{n_1 n_2} \frac{0.5 + \ln(d/a)}{b}, \quad (14)$$

where  $E_1$  is additional energy to projectile, J;  $l_1$  is additional length of barrel, m;  $i_1$  is average electric current after switch of the electric source, A; the other notations are same with previous equations.

The estimations for typical parameters of Railgun show the increasing of speed is about 30 ÷ 40%, but the requested lengthening of the barrel is ~ 3 – 5 times.

**6. Radio impulse.** The plasma flush produces also the powerful electro-magnetic impulse which decamouflage of the Railgun. The energy of this impulse equals about the energy of inductive energy. Let us to estimate the period (frequency) of electromagnetic impulse. We consider the Railgun as an oscillation circuit from magnetic spool and condenser.

$$T = 2\pi \sqrt{L_i C}, \quad L_i = \frac{\mu_o l}{2} \left( 0.5 + \ln \frac{d}{a} \right), \quad C = \frac{\pi \varepsilon_o l}{\ln(d/a)}, \quad T = \sqrt{2} \pi^{3/2} \frac{l}{c} \sqrt{1 + \frac{0.5}{\ln(d/a)}}, \quad (15)$$

Where  $C$  is capacity of Railgun as condenser, C;  $c = 1/\sqrt{\varepsilon_o \mu_o} = 3 \cdot 10^8$  is the light speed in vacuum, m/s .

The estimation shows that radio impulse of Railgun is located in the metric diapason. (octave)

$$T = 1/\nu \approx 2.7 \cdot 10^{-8} l. \quad (16)$$

Equations (13), (14) are correct for condition  $r \leq 2\sqrt{L/C}$  . Where  $r$  is an ohm resistance,  $\Omega$ . This condition is correct in our case. That means the radio locator can catch the shot in distance of thousand kilometers.

**8. Voltage in moment projectile disconnection.** In moment of disconnection all inductive energy locates in a rail magnetic field. If that is transferred into the condenser energy the condenser voltage will be

$$E_c = E_i, \quad \frac{CU^2}{2} = \frac{i^2 L_i}{2}, \quad U^2 = \left[ \frac{\mu_o}{2\pi \varepsilon_o} \left( 0.5 + \ln \frac{d}{a} \right) \ln \frac{d}{a} \right] i^2, \quad (17)$$

for  $\ln \frac{d}{a} = 3, \quad U \approx 6.85 \cdot 10^2 i,$

where  $E_c$  is maximal energy of condenser, J;  $U$  is the maximal voltage, V.

The electric current is very high (some million volts). That way the voltage in rails in disconnection of projectile is also very high (tens of millions volts).



Below into Table 1 it is presented the summary comparison of different versions of the offered multi-loop magnetic launchers (low current magnetic accelerators) for *same acceleration force*.

**Table 1.** Comparison of launchers

Type of launchers	Electric current	Max. accel. voltage	Number of contacts	Useful mass of projectile	Inductive eff. coefficient	General eff. coefficient
Conventional railgun	$i_o$	$U_o$	$N = 2$	$m_o$	$\eta_{io} \approx 0.53$	$\eta_o$
Offered railgun Version 1	$i = i_o / \sqrt{n_1}$	$U = \sqrt{n_1} U_o$	$N = 2$	$m < m_o$	$\eta_i > \eta_{io}$	$\eta > \eta_o$
Offered railgun Version 2	$i = i_o / n_2$	$U = n_2 U_o$	$N = 2n_2$	$m = m_o$	$\eta_i = \eta_{io}$	$\eta > \eta_o$
Offered railgun Version 3	$i = i_o / \sqrt{n_1 n_2}$	$U = \sqrt{n_1 n_2} U_o$	$N = 2n_2$	$m \leq m_o$	$\eta_i > \eta_{io}$ for $n_1 > n_2$	$\eta > \eta_o$

### Computation of the Permanent Magnetic AB-Launcher (fig.4).

In this design the vertical wire changes the permanent magnets. Here we can have also four design (versions) of fig.3a-d. Let us to give the computation equations for these cases.

1. *Conventional railgun (one horizontal jumper, fig.3a).*

$$F = lBi, \quad U = lBV, \quad (18)$$

where  $l$  is length of wire into an intensity magnetic field of permanent magnate,  $m$  (see Fig.4b);  $B$  is magnetic intensity into area of active wire,  $T$ .

2. *Multi-loops launcher (having only horizontal loops, fig.3b).*

$$F = lBn_1i, \quad U = lBn_1V, \quad (19)$$

3. *Multi-loops launcher (having only vertical loops, fig.3c).*

$$F = lBni, \quad U = lBnV, \quad (20)$$

4. *Multi-loops launcher (having horizontal and vertical loops, fig.3d).*

$$F = lBn_1n_2i, \quad U = lBn_1n_2V. \quad (21)$$

The launcher with the permanent magnet having a lot of coils has a small current. That can have a spring vertical wire and not have a sliding contact (fig.4c).

The properties of launchers with permanent magnets are strong depending from  $B$ . Below is short information about magnets.

### **Short information about Magnets** [16]-[23].

**Neodymium magnets** are very strong relative to their mass, but are also mechanically fragile. High-temperature grades will operate at up to 200 and even 230°C but their strength is only marginally greater than that of a samarium-cobalt magnet. As of 2008 neodymium magnets cost about \$44/kg, \$1.40 per BHmax.

Most neodymium magnets are anisotropic, and hence can only be magnetized along one direction although B10N material is isotropic. During manufacture fields of 30-40 kOe are required to saturate the material. Neodymium magnets have a coercivity (required demagnetisation field from saturation) of about 10,000-12,000 Oersted. Neodymium magnets (or “neo” as they are known in the industry) are graded in strength from N24 to the strongest, N55. The theoretical limit for neodymium magnets is grade N64. The number after the N represents the magnetic energy product, in megagauss-oersteds (MGOe) ( $1 \text{ MG} \cdot \text{Oe} = 7,958 \cdot 10^3 \text{ T} \cdot \text{A/m} = 7,958 \text{ kJ/m}^3$ ). N48 has a remnant static magnetic field of 1.38 teslas and an  $H$  (magnetic field intensity) of 13,800 Oersteds (1.098 MA/m). By volume one requires about 18 times as much ceramic magnetic material for the equivalent magnet lifting strength,

and about 3 to 5 times as much for the equivalent dipole moment. A neodymium magnet can hold up to 1300 times its own weight.

The neodymium magnet industry is continually working to push the maximum energy product (strength) closer to the theoretical maximum of 64 MGOe. Scientists are also working hard to improve the maximum operating temperature for any given strength.

*Physical and mechanical properties:* Electrical resistivity 160  $\mu\text{-ohm-cm/cm}^2$ ; Density 7.4-7.5  $\text{g/cm}^3$ ; Bending strength 24  $\text{kg/mm}^2$ ; Compressive strength 80  $\text{kg/mm}^2$ ; Young's modulus  $1.7 \times 10^4 \text{ kg/mm}^2$ ; Thermal conductivity 7.7  $\text{kcal/m-h-}^\circ\text{C}$ ; Vickers hardness 500 – 600.

**Samarium-cobalt** magnets are primarily composed of samarium and cobalt. They have been available since the early 1970s. This type of rare-earth magnet is very powerful, however they are brittle and prone to cracking and chipping. Samarium-cobalt magnets have Maximum Energy Products (BH<sub>max</sub>) that range from 16 Mega-Gauss Oersteds (MGOe) to 32 MGOe, their theoretical limit is 34 MGOe. Samarium Cobalt magnets are available in two "series", namely Series 1:5 and Series 2:17.

*Material properties:* Density: 8.4  $\text{g/cm}^3$ ; Electrical Resistivity  $0.8 \times 10^{-4} \Omega \cdot \text{cm}$ ; Coefficient of thermal expansion (perpendicular to axis): 12.5  $\mu\text{m}/(\text{m} \cdot \text{K})$ .

**Alnico** is an acronym referring to alloys which are composed primarily of aluminium (symbol Al), nickel (symbol Ni) and cobalt (symbol Co), hence *al-ni-co*, with the addition of iron, copper, and sometimes titanium, typically 8–12% Al, 15–26% Ni, 5–24% Co, up to 6% Cu, up to 1% Ti, and the balance is Fe. The primary use of alnico alloys is magnet applications.

Alnico remanence (**B<sub>r</sub>**) may exceed 12,000 G (1.2 T), its coercion force (**H<sub>c</sub>**) can be up to 1000 oersted (80 kA/m), its energy product (**(BH)<sub>max</sub>**) can be up to 5.5 MG·Oe (44 T·A/m)—this means alnico can produce high magnetic flux in closed magnetic circuit, but has relatively small resistance against demagnetization.

As of 2008, Alnico magnets cost about \$20/pound or \$4.30/BH<sub>max</sub>.

**Electrolytic steel.** The good properties have conventional electrolytic steel, which uses in conventional electric engines, electric machines, transformer. That is cheap, has the magnetic intensity up 1.7 T and easy magnetize. After shot the magnate with outer magnetizing returns the induced energy in an electric network. The magnetic field is created only in shot.

### Computation of the Plasma Magnetic Launcher

The Plasma Magnetic Launcher is computed as the conventional Railgun. The specific electric resistance is computed by equation

$$\rho = 1.03 \cdot 10^{-4} z T^{-3/2} \ln \Lambda, \quad [\Omega \cdot \text{m}], \quad (22)$$

where  $z$  is ion charge (conventional  $z = 1$ );  $T$  is plasma temperature in eV;  $\ln \Lambda$  is Coulombs logarithm ( $\ln \Lambda \approx 3 \div 10$ ). The electric resistance of plasma for  $T = 100$  eV is close to metal conductors. However the plasma jumper can have a large contact area, have a small mass and a gas sliding contact.

## Projects

The most suitable computation for the proposed projects is made in examples in Theoretical section. That way much data is given without detailed explanation. Our design is not optimal but merely for estimation of the main data.

### Project. AB-Accelerator for warship projectile

The DARPA and NAVY (USA) and UK have a program for the warship railgun capable to accelerate a 2 kg projectile up to speeds of 3 km/s (see end of Introduction). We take the common projectile mass  $m = 10$  kg (projectile + wire system), final speed  $V = 3$  km/s and estimate the parameters of the suggested accelerator.

Let us take the projectile acceleration  $a = 10^5 g = 10^6 \text{ m/s}^2$ . The requested force is  $F = ma = 10^7 \text{ N}$ , the requested length of barrel is  $S = V^2/2a = 4.5 \text{ m}$ , the acceleration time is  $t = V/a = 0.003 \text{ sec}$ . Kinetic energy of projectile is  $E = mV^2/2 = 4.5 \cdot 10^7 \text{ J}$ . The average power is  $P = E/t = 1.5 \cdot 10^{11} \text{ W}$ .

The needed electric current and some other parameters for different versions  $d = 0.05 \text{ m}$ ,  $b = 2$  (see Eq. (1) - (4)) is:

1) *Version 1 (conventional,  $n = 1$ )*. Request current is  $i \approx 3.54 \cdot 10^6 \text{ A}$ . The maximal acceleration voltage (Eq.(3)) is  $U_m = 8.5 \cdot 10^3 \text{ V}$ . The maximal only projectile power  $P_m = iU_m = 3 \cdot 10^{10} \text{ W}$ . The safety density of the electric current without cooling is  $j = 7.55 \cdot 10^3 \text{ A/mm}^2$ , (Eq. (10),  $\Delta T_m = 80^\circ\text{K}$ ). Cross section of rail is  $s = i/j = 4.7 \cdot 10^2 \text{ mm}^2$ .

Let us take the distance between vertical wire  $d = 0.05 \text{ m}$ . The repulse force between vertical wire is (Eq.(5))  $= 5 \cdot 10^7 \text{ N/m}$ .

2) *Version 2 ( $n_1 = 100$ )*. Request current is  $i \approx 3.54 \cdot 10^5 \text{ A}$ . The maximal acceleration voltage (Eq.(3)) is  $U_m = 8.5 \cdot 10^4 \text{ V}$ . The maximal only projectile power  $P_m = iU_m = 3 \cdot 10^{10} \text{ W}$ . The safety density of the electric current is  $j = 7.55 \cdot 10^3 \text{ A/mm}^2$ , (Eq. (10),  $\Delta T_m = 80^\circ\text{K}$ ). Cross section of rail is  $s = i/j = 4.7 \cdot 10^1 \text{ mm}^2$ . Let us take the distance between vertical wire  $d = 0.05 \text{ m}$ . The repulse force between vertical wire is (Eq.(5))  $= 5 \cdot 10^5 \text{ N/m}$ .

The heat loss and plasma flash decreases approximately in 10 times, but useful mass of projectile decreases about 60% because the wire spool at projectile has a mass.

3) *Version 3* is combination of version 1 and 2.

4) *Version 4* does not have lacks of version 2, but one has more contacts ( $N = 2n$ ) with weaker electric current (by  $n$  times).

## Conclusion

In this article the author describes the new ideas, theory and computations for design the new low electric current launchers for the railgun projectile and space apparatus.

Important advantage of the offered design is the lower (up some tens times) used electric current of high voltage and the very high inductive efficiency coefficient close to 0.9 (compared with efficiency of the current railgun equal to 20 – 40%). The suggested launchers may be produced by present technology.

The problems of needed electric energy become far simpler. At first, AB-Launchers have a high efficiency and spend in 2 – 3 times less energy than a conventional railgun; the second, AB-Launcher uses the high voltage energy closed to a voltage of the electric stations. That means the power electric station can be directly connected to AB-Launcher in period of acceleration without expensive transformers and condensers. The power of strong electric plant is enough for launching the space apparatus of some hundreds of kilograms.

The offered magnetic space launcher is a thousand times cheaper than the well-known cable space elevator. NASA is spending for research of space elevator hundreds of millions of dollars. A small part of this sum is enough for R&D of the magnetic launcher and to make a working model.

The proposed innovation (multi- electric AB-spool, permanent magnetic rails, plasma magnetic launcher) allows also solving the problem of the conventional railgun (having the projectile speed 3 -5 km/s). The current conventional railgun uses a very high ampere electric current (millions A) and low voltage. As the result the rails corrode, burn, melt The suggested AB-spool allows decreases the required the electric current by tens of times (simultaneously the required voltage is increased by the same factor).

Small cheap magnetic prototypes would be easily tested.

The computed projects are not optimal. That is only illustration of an estimation method. The reader can recalculate the AB-Launchers for his own scenarios (see also [1]-[23]).

## References

(The reader may find some of these articles, at the author's web page: <http://Bolonkin.narod.ru/p65.htm> , in <http://www.scribd.org> , in the WEB of Cornell University <http://arxiv.org> , and in <http://aiaa.org> search term "Bolonkin")

1. Bolonkin A.A., Magnetic Space AB-Accelerator. <http://www.scribd.com/doc/26885058>
2. Bolonkin A.A., Non-Rocket Space Launch and Flight, Elsevier, 2006, 488 pgs. <http://www.scribd.com/doc/24056182> , <http://Bolonkin.narod.ru/p65.htm> .
3. Bolonkin A.A., New Concepts, Ideas and Innovations in Aerospace, Technology and Human Sciences, NOVA, 2007, 502 pgs. <http://www.scribd.com/doc/24057071>, <http://Bolonkin.narod.ru/p65.htm>
4. Bolonkin A.A., Cathcart R.B., Macro-Projects: Environment and Technology, NOVA, 2008, 537 pgs. <http://www.scribd.com/doc/24057930> . <http://Bolonkin.narod.ru/p65.htm> .
5. Bolonkin A., Magnetic Suspended AB-Structures and Immobile Space Stations, <http://www.scribd.com/doc/25883886>
6. Bolonkin A., Krinker M., Magnetic Space Launcher. Presented as paper AIAA-2009-5261 to 45<sup>th</sup> AIAA Joint Propulsion Conference, 2-5 August 2009, Denver, CO, USA. <http://www.scribd.com/doc/24051286> or <http://aiaa.org> search "Bolonkin".
7. Bolonkin A.A., Earth Accelerator for Space Ships and Missiles, *JBIS*, Vol. 56, No. 11/12, 2003, pp. 394–404. <http://Bolonkin.narod.ru/p65.htm>
8. Bolonkin A.A., "Space Cable Launchers", Paper No. 8057 presented at the Symposium "The Next 100 years", Dayton, OH, USA, 14-17 July, 2003. <http://Bolonkin.narod.ru/p65.htm>
9. Bolonkin A.A., Centrifugal Space Launcher, Presented as paper AIAA-2005-4035 at the 41<sup>st</sup> Propulsion Conference, 10-12 July 2005, Tucson, AZ, USA. <http://aiaa.org>, <http://www.scribd.com/doc/24056182> Ch.10.
10. Bolonkin A.A., Electrostatic Linear Engine and Cable Space AB Launcher, Paper AIAA-2006-5229 for 42 Joint Propulsion Conference, Sacramento, USA, 9-12 July, 2006. See also AEAT Vol.78, No.2006, pp. 502-508. <http://aiaa.org>, <http://Bolonkin.narod.ru/p65.htm>
11. Bolonkin A., Krinker M., Magnetic Propeller for Uniform Magnetic Field Levitation <http://arxiv.org/ftp/arxiv/papers/0807/0807.1948.pdf> (12 July, 2008).
12. Bolonkin A., Krinker M.. Magnetic Propeller. Article presented as paper AIAA-2008-4610 to 44th Joint Propulsion Conference, 20-24 July, 2008, Hartford, CT, <http://aiaa.org> .
13. Bolonkin A., Krinker M. , Magnetic Propeller for Uniform Magnetic Field. (Ch.13 . in the book "Macro-Projects: Environment and Technology", NOVA, 2008) <http://www.scribd.com/doc/24057930> . <http://Bolonkin.narod.ru/p65.htm>
14. AIP. Physics Desk References, 3-rd Edition. Springer. 2003.
15. Krinker M., Review of New Concepts, Ideas and Innovations in Space Towers. <http://www.scribd.com/doc/26270139>, <http://arxiv.org/ftp/arxiv/papers/1002/1002.2405.pdf>
16. Galasso F.S., Advanced Fibers and Composite. Gordon and Branch Science Publisher, 1989.
17. Kikoin I.K., Editor. Table of Physical Values, Moscow, 1976, 1007 ps. (in Russian).
18. Koshkin H.I., Shirkevich M.G., Directory of Elementary Physics, Nauka, 1982.
19. Koell D.E., *Handbook of Cost Engineering*, TCS, Germany, 2000.
20. Minovich M., "Electromagnetic Transportation System for Manned Space Travel", US Patent #4,795,113, January 3, 1989.
21. Nасhekin V.V., Technical Thermodynamics and Heat Transfer, Moscow, 1969 (in Russian).
22. *Wikipedia*. Some background material in this article is gathered from Wikipedia under the Creative Commons license. <http://wikipedia.org> .
23. <http://NASA-NIAC.narod.ru> , <http://auditing-science.narod.ru>

## Chapter 10

# Superconductivity Space Accelerator

### Abstract

In this Chapter the author describes a new idea, theory and computations for design of a new magnetic low cost accelerator for railgun projectile and space apparatus. The suggested design does not have the traditional current rails and sliding contacts. This accelerates the projectile and space apparatus by a magnetic column which can have a length of some kilometers, produces a very high acceleration and projectile (apparatus) final speed of up to 8 - 10 km/s.

Important advantages of the offered design is the low (up to some thousands of times) used electric current of high voltage and very high efficiency coefficient close to 1 (compare with efficiency of the current railgun which equals 20 – 40%). The suggested accelerator may be produced by present technology.

The projects: railgun and space accelerator are computed.

-----  
**Key words:** railgun, space launcher, magnetic space launcher, magnetic accelerator, AB-Accelerator .

### 1. Introduction

At present, rockets are used to carry people and payloads into space, or to deliver bombs over long distances. This method is very expensive, and requires a well-developed industry, high technology, expensive fuel, and complex devices.

Other than rockets, methods to reach altitudes and speeds of interest (even prospectively) are the space elevator, the hypersonic tube air rocket, cable space accelerator, circle launcher and space keeper, centrifugal launcher [1-9], electrostatic liner accelerator [10]. Several new non-rockets methods were also proposed by the author at the World Space Congress-2002, Houston, USA, 10 – 19 October 2002.

The space elevator requires very strong nanotubes, as well as rockets and high technology for the initial development. The tube air rocket and non-rocket systems require more detailed research. The electromagnetic transport system, suggested by Minovich (US Patent, 4,795,113, 3 January, 1989)[11], is not realistic at the present time. It requires a vacuum underground tunnel 1530 kilometers long located at a depth of 40 kilometers. The project requires an active cooling system (because the temperature is very high at this depth), a complex power electromagnetic system, and a huge impulse of energy that is greater than the energy of all the electric generating stations on Earth.

This article suggests a very simple and inexpensive method and installation for launching into space.

This is a new space launcher system for delivering hypersonic speeds. This method uses a low electric current (but a high voltage). Installation does not have a electric current rail or sliding electric contact and has a very high efficiency. This method requires superconductivity, but this problem is successfully solved by author's innovations in design of the working superconductivity wire.

#### General information about previous works regarding to this topic.

Below is common information useful for understanding proposed ideas and research.

A **rocket** is a vehicle, missile or aircraft which obtains thrust by the reaction to the ejection of fast moving fluid from within a rocket engine. Chemical rockets operate due to hot exhaust gas made from "propellant" acting against the inside of an expansion nozzle. This generates forces that both accelerate

the gas to extremely high speed, as well as, since every action has an equal and opposite reaction, generating a large thrust on the rocket.

The history of rockets goes back to at least the 13th century, possibly earlier. By the 20th century it included human spaceflight to the Moon, and in the 21st century rockets have enabled commercial space tourism.

Rockets are used for fireworks and weaponry, as launch vehicles for artificial satellites, human spaceflight and exploration of other planets. While they are inefficient for low speed use, they are, compared to other propulsion systems, very lightweight, enormously powerful and can achieve extremely high speeds.

Chemical rockets contain a large amount of energy in an easily liberated form, and can be very dangerous, although careful design, testing, construction and use can minimise the risks.

A rocket engine is a jet engine that takes all its reaction mass ("*propellant*") from within tankage and forms it into a high speed jet, thereby obtaining thrust in accordance with Newton's third law. Rocket engines can be used for spacecraft propulsion as well as terrestrial uses, such as missiles. Most rocket engines are internal combustion engines, although non combusting forms also exist.

**Railgun.** Scientists use a railgun for high acceleration of a small conducting body. A railgun is a form of gun that converts electrical energy (rather than the more conventional chemical energy from an explosive propellant) into projectile kinetic energy. It is not to be confused with a coilgun (Gauss gun). Rail guns use magnetic force to drive a projectile. Unlike gas pressure guns, rail guns are not limited by the speed of sound in a compressed gas, so they are capable of accelerating projectiles to extremely high speeds (many kilometers per second).

A wire carrying an electrical current, when in a magnetic field, experiences a force perpendicular to the direction of the current and the direction of the magnetic field.

In an electric motor, fixed magnets create a magnetic field, and a coil of wire is carried upon a shaft that is free to rotate. An electrical current flows through the coil causing it to experience a force due to the magnetic field. The wires of the coil are arranged such that all the forces on the wires make the shaft rotate, and so the motor runs.

A railgun consists of two parallel metal rails (hence the name) connected to an electrical power supply. When a conductive projectile is inserted between the rails (from the end connected to the power supply), it completes the circuit. Electrical current runs from the positive terminal of the power supply up the positive rail, across the projectile, and down the negative rail, back to the power supply. This flow of current makes the railgun act like an electromagnet, creating a powerful magnetic field in the region of the rails up to the position of the projectile. In accordance with the right-hand rule, the created magnetic field circulates around each conductor. Since the current flows in opposite direction along each rail, the net magnetic field between the rails ( $\mathbf{B}$ ) (see Ch.7, Fig.1) is directed vertically. In combination with the current ( $\mathbf{I}$ ) flowing across the projectile, this produces a Lorentz force which accelerates the projectile along the rails. The projectile slides up the rails away from the end with the power supply.

If a very large power supply providing a million amperes or so of current is used, then the force on the projectile will be tremendous, and by the time it leaves the ends of the rails it can be travelling at many kilometres per second. 20 kilometers per second has been achieved with small projectiles explosively injected into the railgun. Although these speeds are theoretically possible, the heat generated from the propulsion of the object is enough to rapidly erode the rails. Such a railgun would require frequent replacement of the rails, or use a heat resistant material that would be conductive enough to produce the same effect. Please notice the gigantic cloud of plasma behind the projectile. That is the result of a electric arc between the contacts. About 70 – 80% of electric energy is lost uselessly.

The need for strong conductive materials with which to build the rails and projectiles; the rails need to survive the violence of an accelerating projectile, and heating due to the large currents and friction involved acts against the longevity of the system. The force exerted on the rails consists of a recoil force - equal and opposite to the force propelling the projectile, but along the length of the rails (which is their strongest axis) - and a sideways force caused by the rails being pushed by the magnetic field, just as the projectile is. The rails need to survive this without bending, and thus must be very securely mounted.

The power supply must be able to deliver large currents, with both capacitors and compulsators being common.

The rails need to withstand enormous repulsive forces during firing, and these forces will tend to push them apart and away from the projectile. As rail/projectile clearances increase, electrical arcing develops, which causes rapid vaporization and extensive damage to the rail surfaces and the insulator surfaces. This limits most research railguns to one shot per service interval.

Some have speculated that there are fundamental limits to the exit velocity due to the inductance of the system, and particularly of the rails; but United States government has made significant progress in railgun design and has recently floated designs of a railgun that would be used on a naval vessel. The designs for the naval vessels, however, are limited by their required power usages for the magnets in the rail guns. This level of power is currently unattainable on a ship and reduces the usefulness of the concept for military purposes.

Massive amounts of heat are created by the electricity flowing through the rails, as well as the friction of the projectile leaving the device. This leads to three main problems: melting of equipment, safety of personnel, and detection by enemy forces. As briefly discussed above, the stresses involved in firing this sort of device require an extremely heat-resistant material. Otherwise the rails, barrel, and all equipment attached would melt or be irreparably damaged. Current railguns are not sufficiently powerful to create enough heat to damage anything; however the military is pushing for more and more powerful prototypes. The immense heat released in firing a railgun could potentially injure or even kill bystanders. The heat released would not only be dangerous, but easily detectable. While not visible to the naked eye, the heat signature would be unmistakable to infrared detectors. All of these problems can be solved by the invention of an effective cooling method.

Railguns are being pursued as weapons with projectiles that do not contain explosives, but are given extremely high velocities: 3500 m/s (11,500 ft/s) or more (for comparison, the M16 rifle has a muzzle speed of 930 m/s, or 3,000 ft/s), which would make their kinetic energy equal or superior to the energy yield of an explosive-filled shell of greater mass. This would allow more ammunition to be carried and eliminate the hazards of carrying explosives in a tank or naval weapons platform. Also, by firing at higher velocities railguns have greater range, less bullet drop and less wind drift, bypassing the inherent cost and physical limitations of conventional firearms - *"the limits of gas expansion prohibit launching an unassisted projectile to velocities greater than about 1.5 km/s and ranges of more than 50 miles [80 km] from a practical conventional gun system."*

If it is ever possible to apply the technology as a rapid-fire automatic weapon, a railgun would have further advantages in increased rate of fire. The feed mechanisms of a conventional firearm must move to accommodate the propellant charge as well as the ammunition round, while a railgun would only need to accommodate the projectile. Furthermore, a railgun would not have to extract a spent cartridge case from the breech, meaning that a fresh round could be cycled almost immediately after the previous round has been shot.

**Tests of Railgun.** Full-scale models have been built and fired, including a very successful 90 mm bore, 9 MJ (6.6 million foot-pounds) kinetic energy gun developed by DARPA, but they all suffer from extreme rail damage and need to be serviced after every shot. Rail and insulator ablation issues still need to be addressed before railguns can start to replace conventional weapons. Probably the most successful system was built by the UK's Defence Research Agency at Dundrennan Range in



Kirkcudbright, Scotland. This system has now been operational for over 10 years at an associated flight range for internal, intermediate, external and terminal ballistics, and is the holder of several mass and velocity records.

The United States military is funding railgun experiments. At the University of Texas at Austin Institute for Advanced Technology, military railguns capable of delivering tungsten armor piercing bullets with kinetic energies of nine million joules have been developed. Nine mega-joules is enough energy to deliver 2 kg of projectile at 3 km/s - at that velocity a tungsten or other dense metal rod could penetrate a tank.

The United States Naval Surface Warfare Center Dahlgren Division demonstrated an 8 mega-joule rail gun firing 3.2 kilogram (slightly more than 7 pounds) projectiles in October of 2006 as a prototype of a 64 mega-joule weapon to be deployed aboard Navy warships. Such weapons are expected to be powerful enough to do a little more damage than a BGM-109 Tomahawk missile at a fraction of the projectile cost.

Due to the very high muzzle velocity that can be attained with railguns, there is interest in using them to shoot down high-speed missiles.

## **Description of Innovations and Problems**

### **New type of magnetic acceleration (magnetic AB-column)**

**1. Description of Innovations.** The conventional magnetic accelerator (railgun) is shown in fig.1. That contains two the conductive rails connected by a **sliding** jumper. Electric currents produce the magnetic field and magnetic force. The jumper accepts the magnetic force and accelerates the projectile. Main defects of conventional rail gun: The rail gun requires a gigantic current (millions of amperes) of low voltage, rails have large electric resistance, strongly heating up, contacts burn, installation is damaged and requires repair after every shot. The energy charge is high (small coefficient of efficiency. You see the gigantic plasma column behind the small projectile in fig.2). The repulsive force between rails is gigantic (thousands of tons) and installation is thus heavy and expensive if it is to survive a single shot.

*Description.* The fig.3a shows the suggested accelerator without the force and connection spools. Installation includes the long vertical loop from electric wire 1 and electric source 6. The electric current 2 produces the magnetic field 3 (magnetic column), the magnetic field creates the vertical 4 and horizontal 5 forces. These forces balance the film (or filament, fiber) connection 15. Vertical force 4 accelerates the useful load at top of the installation and supports wires and film connection).

This design is used in a rail gun [5] but the author made many innovations that allow applying this idea to this new application as an efficient magnetic accelerator. Some of them are listed below.

*Innovations.* The author offers the following innovations having the next advantages:

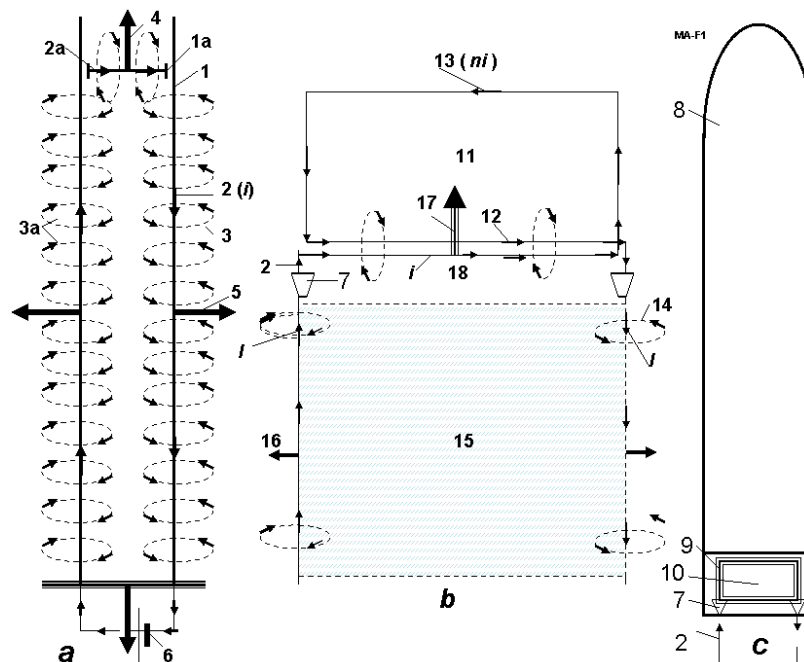
- 1) The horizontal wire (fig.3a, #2a, former sliding jumper of fig.2) is made in a form of closed-loop spool (fig.3b, #11). The lower part of this spool (fig.3b, #12) located in place of former jumper near the magnetic field of vertical wire (fig.3b). The top part of this spool (fig.3b, #13) located at top – out of the magnetic field of vertical wire 2. As the result the magnetic field of the vertical wire 2 activates only on horizontal wires 12. But now we have here not one wire 2a with current  $i$ , we have  $n$  wires and current  $ni$ . The magnetic force 17 and requested voltage increases by  $n$  times! The force spool 11 can have some thousands loops and force 17 will be more in same times then in case 2a of fig 3a. That means the electric current in the connection wires 2 may be relatively small (only some thousands of amperes, not millions) and of high voltage. The request vertical wire may be relatively thin.

- 2) Application of special connection spool. The accelerator has the connection spool 7 (fig.3, detail spool in fig.4). That allows increases the acceleration distance up to some kilometers and deletes the sliding electric contacts.
- 3) The wire is superconductive and has special design (fig.4). That allows simply cooling the wires in a short time (the superconductivity needs a low temperature). Their cooling time may be short because requested time of acceleration may be short. For example, rail gun shot lasts about 0.1 second, the space apparatus acceleration is about tens seconds.
- 4) Absence of long rails. ‘Confinement recoil’ of projectile is accepted by the magnetic columns 3a (fig.3a) from vertical wires [4].

The main innovation is a top loop 11 (right angle spool [4]), which increases the number of horizontal wires 12, magnetic intensity in area 17 and lift force 16. We can make a lot of loops up to some thousands and increase the lift force by thousands of times. For a given lift force we can decrease the required current in many times and decreases the mass of source wire 2. That does not necessarily mean that we decrease the required electric power because the new installation needs a higher voltage. The proposed construction creates the MAGNETIC COLUMN 3a that produces a lift force some thousands of times more than a conventional rail gun.

The second important innovation is the connection spool, which increases the acceleration distance, deletes the sliding contacts and heavy rails.

*Quadratic magnetic column.* The quadratic four wire magnetic column ([4], Fig.2) is more efficient, stable, safe, reliable and controlled than two wire magnetic column Fig.1. It can control of space ship direction (by changing current in vertical wires). It is important for high altitude space apparatus.



**Fig.1.** Principal sketch of the Magnetic AB-Accelerator. *Notations:* (a) Principal sketch of conventional (one turn) magnetic accelerator, (b) – Multi-loop force spool at top of accelerator (same force spool located at ground), (c) – rocket (projectile) with detachable magnetic accelerator at bottom. *Parts:* 1 – magnetic installation with magnetic column, 1a – sliding contact, 2 – vertical wire and direction of electric current  $i$ , 2a – horizontal wire (jumper) and direction of electric current  $i$ , 3 – magnetic field from vertical electric wire, 3a – magnetic column, 4 – magnetic force from horizontal electric wire (jumper), 5 – magnetic force from vertical electric wire, 6 – electric source, 7 – connection spool, 8 – rocket (projectile),

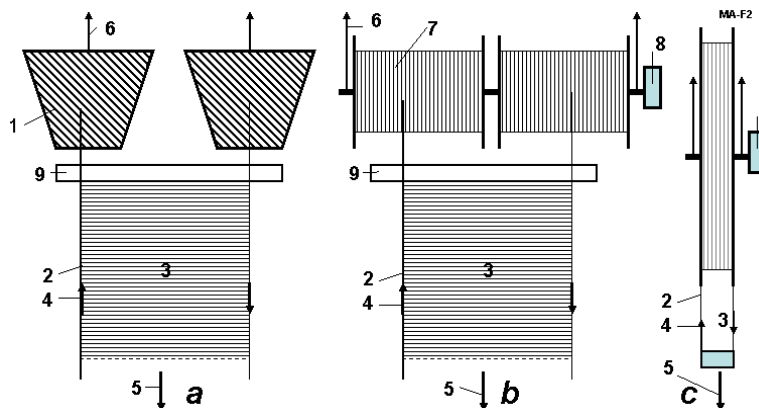
9 – force spool, 10 – magnetic accelerator, 11 – wire multi-loop superconductive force spool at top (same spool located also on Earth surface), 12 – lower wires of loop (force spool), 13 – top wires of loop (force spool), 14 – magnetic field from vertical wire, 15 – thin film or artificial fiber connected the vertical wires for compensation the magnetic repulse force, 16 – repulsive magnetic force, 17 – acceleration force, 18 – area strong magnetic field,  $i$  – electric current in vertical wire,  $ni$  – electric current in the force spool.

**2. Connection spools.** The connection spools can be located at accelerator and at the ground. Every design has its advantages and limitations. Three constructions of the connection spools are presented in fig.2. The first design (fig.4a) has immobile vertical spools. That is simple but results in a limited safe high speed of the launched apparatus and requires the connection device 9. The second design (fig.2b) has the horizontal spool rotated by an engine. This connection spool is limited by the safe rotary speed of the spool and also requires the connection device 9. The third design (fig.4c) has engine and also limited by a safety rotary of spool, but it does not request the connection device 9 because the wires are connected by fiber before spooling in the connection spool.

The limitation is about 1 – 3 km/s for the current artificial fiber (whiskers) having a safe tensile stresses about 200 - 1000 kgf/mm<sup>2</sup>. But if we use nanotubes, the limit is more by 5 -10 times.

**3. Cooling system of superconductive wire.** The current superconductive conductors do not spend electric energy and pass very large electric current densities, but they require an cooling system because the current superconductive materials have the critical temperature of about 100 - 180 K (see Table #1 below). The wire located into Earth's atmosphere (up 50 – 80 km) needs cooling.

However, the present computational methods of heat transfer are well developed and the weight and the induced expenses for cooling are small (for example, cooling by liquid nitrogen) [4] (see also Computation and Projects sections).

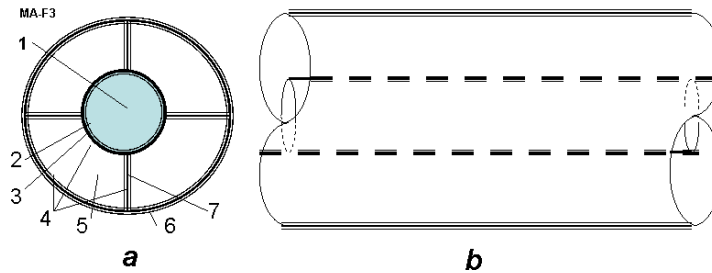


**Fig. 2.** Possible installations of connection spools for AB-Accelerator. *Notations:* (a) Immobile vertical connection spool, (b) Rotated horizontal connection spool, (c) Type connection spool. Parts: 1 – immobile vertical connection spool, 2 – vertical superconductive wire, 3 – filaments connected the vertical wire and keeping the repulsive magnetic force of vertical wires, 4 – electric current, 5 – motion of connection wire, 6 – vertical wire to the force spool, 7 – connection wire in connection spool, 8 – engine for rotation of the connection spool, 9 – device for connection the vertical wires by filaments.

The suggested design of a cooled superconductive wire is present in fig.5. The wire contains two elastic tubes. The insulated internal tube is coated inside-- the superconductive layer, outside is coated--the highly reflective layer. The outer tube is made from the strong artificial fiber and covered by the highly reflective layers. The space between tubes is vacuumed or filed by air (it is worse but may apply for short cooling time) or heat protection.

The wire works the following way. The liquid nitrogen (77 K) from special heat protection capsule is injected into the internal tube in many places (needles) and instantly cooling the superconductive layer to lower than the critical temperature.

While the nitrogen evaporates the temperature is 77 K and installation can accelerate the projectile or space apparatus. After acceleration the accelerator separates, wires are spooling and installation is ready for next shot.



**Fig.3.** Superconductive wires. (a) Cross-section of superconductive wires, (b) – side view. *Notations:* 1 - strong elastic tube (internal part is used for cooling of superconductive layer by liquid nitrogen, external part is used for reflective layer), 2 – superconductive layer, 3 - insulator, 4 – high reflective layer, 5 – vacuum or air, or heat-insulated material (fiber), 6 – strong outer tube (internal and external surface is covered by reflective coating), 7 – connection the internal and outer tubes.

#### 4. Superconductive materials.

There are hundreds of new superconductive materials (type 2) having critical temperature  $70 \div 120$  K and more. Some of the superconductive materials are presented in Table 1 (2001). The widely used  $\text{YBa}_2\text{Cu}_3\text{O}_7$  has mass density  $7 \text{ g/cm}^3$ .

**Table 1.** Transition temperature  $T_c$  and upper critical magnetic field  $B = H_{c2}(0)$  of some examined superconductors [14 ], p. 752.

Crystal	$T_c$ (K)	$H_{c2}$ (T)
$\text{La}_{2-x}\text{Sr}_x\text{CuO}_4$	38	$\geq 80$
$\text{YBa}_2\text{Cu}_3\text{O}_7$	92	$\geq 150$
$\text{Bi}_2\text{Sr}_2\text{Ca}_2\text{Cu}_3\text{O}_{10}$	110	$\geq 250$
$\text{TlBa}_2\text{Ca}_2\text{Cu}_3\text{O}_9$	110	$\geq 100$
$\text{Tl}_2\text{Ba}_2\text{Ca}_2\text{Cu}_3\text{O}_{10}$	125	$\geq 150$
$\text{HgBa}_2\text{Ca}_2\text{Cu}_3\text{O}_8$	133	$\geq 150$

The last decisions are: Critical temperature is 176 K, up to 183 K. Nanotube has critical temperature of 12 - 15 K,

Some organic matters have a temperature of up to 15 K. Polypropylene, for example, is normally an insulator. In 1985, however, researchers at the Russian Academy of Sciences discovered that as an oxidized thin-film, polypropylene have a conductivity  $10^5$  to  $10^6$  that is higher than the best refined metals.

Boiling temperature of liquid nitrogen is 77.3 K, air 81 K, oxygen 90.2 K, hydrogen 20.4 K, helium 4.2 K [17]. Specific density of liquid air is  $920 \text{ kg/m}^3$ , nitrogen  $804 \text{ kg/m}^3$ ; evaporation heat is liquid air is 213 kJ/kg, nitrogen 199 kJ/kg [18].

Unfortunately, most superconductive material is not strong and needs a strong covering for structural support.

**5. Advantages.** The offered magnetic accelerator has big advantages in comparison with railguns and other space launchers. Compare it with the space rocket.

1. The AB-Accelerator is very cheap. The cost is about one million USD (rail gun) to some millions (space launcher) [19].
2. The consumables cost is very small and primarily the needed electric energy (about 3 – 5 \$/kg)[19].
3. The productivity is very high (tens launches in day).
4. The accelerator uses the current well developed technology and may be researched and developed in a short time.
5. The accelerator (special platform) may initially to accelerate current rockets up to speed 700 – 1000 m/s and lift them to the altitude 5 – 10 km. That increases the payload the current rockets up 50% .
6. Accelerator uses the high voltage (up to 1 MV) electric currency. That allows to directly connect accelerator to current power electric stations (in night time during periods of slack power use) and to launch a space apparatus without expensive electric energy storage in the form of capacitors (used in present time).
7. Accelerator has a coefficient of energy efficiency closed to 1. It is the most efficient among the known space launchers.

In comparison with current Railgun the suggested accelerator has the following advantages:

1. No problem with burn of rail and contact.
2. No damage and repair of installation after every shot.
3. Limit in speed of projectile is high (7 – 9 km/s).
4. No limit to mass of projectile.
5. Installation is cheaper.
6. Installation requires ~2 – 3 times less of energy than same output conventional railgun.

**6. Application and further development.** Idea of the magnetic AB-column may be applied to the suspending of houses, buildings, towns, multi-floor cities, to a small flying city-state located over ocean in the international water, (avoiding some of the liabilities of sea-surface communities during storms) to levitating space stations, to communication masts and towers [4]. This idea may be easily tested in small cheap magnetic constructions for simple projects, on a small scale.

## Theory of Magnetic AB-Acceleration

**1. Magnetic force acting on horizontal wire.** Proof of magnetic force equation. We use only well-known physical laws (magnetic force on the electric conductor located into magnetic field):

$$dF = niBdl, \quad B = \mu_0 H, \quad H = \frac{i}{2\pi a}, \quad F = \frac{\mu_0 n i^2}{2\pi} \int_a^{d-a} \frac{1}{l} dl = \frac{\mu_0 n i^2}{2\pi} \ln \left| \frac{d-a}{a} \right|. \quad (1)$$

The force from two vertical wires is

$$F = \frac{\mu_0 n i^2}{\pi} \ln \left| \frac{d-a}{a} \right| = \frac{\mu_0 n i^2 b}{\pi}, \quad \text{where } b = \ln \left| \frac{d-a}{a} \right|, \quad (2)$$

where  $F$  is magnetic force, N;  $n$  is number of wire loops at horizontal connection (fig.3, #11)(in proposed force spool), number of wire loops may be some thousands;  $\mu_0 = 4\pi \cdot 10^{-7}$  – magnetic constant, H/m;  $d$  is distance between centers of vertical wire, m;  $a$  is radius of wire (internal tube) or thickness of a conductive layer (plate conductor), m;  $b \approx 5 – 10$ ;  $i$  is electric current in the

vertical and single horizontal wire,  $A$ ;  $H$  is magnetic intensity in V/m,  $B$  is magnetic intensity in T;  $l$  is distance, m.

The magnetic field acts only on the lower horizontal part of the right-angled force spool because the top horizontal part is far from vertical support wire (at top of installation).

The equation (2) without the spools ( $n = 1$ ) is the well-known equation for the rail gun. The proposed innovation (the right-angled force spool) increases the force by  $n$  times but simultaneously increases the required voltage also by  $n$  times if the installation changes its size (for example, altitude) or the projectile moves.

The spool also creates a strong magnetic field but this field acts only on the spool and produces tensile stress only into the spool. It easy is compensated for by film, fiber or composed material (reinforcement) located in the force spool.

Example: for  $i = 10^4$  A,  $n = 10^3$ ,  $b = 10$  the force is  $F = 4 \cdot 10^5$  N = 40 tons. If  $i = 2 \cdot 10^4$  A, the  $F = 160$  tons. If  $i = 10^5$  A, the  $F = 4000$  tons. Approximately that is the weight of the structure, which can be accelerated or suspended over Earth's surface.

The stationary (immovable) installation using superconductive wires doesn't need maintenance (hovering) energy. If installation is lifting (the projectile is moving), the accelerator requires input energy (electric voltage). This voltage and power are computed as below:

$$U = \frac{\mu_0 n i V b}{\pi}, \quad P = iU, \quad (3)$$

where  $V$  is speed of projectile or a top force spool of installation, m/s.

For given force  $F$  the required current is

$$i = \left( \frac{\pi F}{\mu_0 n b} \right)^{0.5}, \quad (4)$$

Example: For  $F = 300,000$  N,  $n = 10^3$ ,  $b = 10$  the  $i = 8.7 \cdot 10^3$  A.

**2. Repulsive force between the vertical wires.** This force  $F_1$  for wire length of 1 m is

$$F_1 = \frac{\mu_0 i^2}{2\pi d}, \quad (5)$$

Example: for  $i = 10^4$  A,  $d = 2$  m, the force is  $F_1 = 10$  N/m = 1 kgf/m.

**3. Mass of film (or fiber) for balance of the repulsive force** of wire in length 1 m:

$$F_1 = \frac{\mu_0 i^2}{2\pi d}, \quad F_2 = \delta\sigma, \quad F_1 = F_2, \quad m_f = \gamma\delta d, \quad m_f = \frac{\mu_0 \gamma}{2\pi\sigma} i^2, \quad (6)$$

Where  $F_2$  is film (fiber) balance force for length 1 m, N/m;  $\gamma$  is specific mass of film (fiber), kg/m<sup>3</sup>;  $\sigma$  is the safety tensile stress of a film (fiber), N/m<sup>2</sup>;  $\delta$  is thickness of film, m;  $m_f$  is mass of film (fiber), kg/m.

Example: for the current cheap artificial fiber  $\gamma = 1800$  kg/m<sup>3</sup>,  $\sigma = 2 \cdot 10^9$  N/m<sup>2</sup> (safety  $\sigma = 200$  kgf/mm<sup>2</sup>) (see Table 3),  $i = 10^4$  A the mass  $m_f = 1.8 \cdot 10^{-5}$  kg/m. That is only 1.8 kg over 100 km of distance.

**4. Mass of superconductive layer.** Mass of 1 m vertical electric wire (superconductive layer) is

$$m_w = \gamma_w s, \quad s = i / j, \quad m_w = \gamma_w i / j, \quad (7)$$

where  $m_w$  is mass of electric wire of 1 m length (only superconductive layer), kg/m;  $\gamma_w$  is specific density of superconductive layer, kg/m<sup>3</sup>;  $s$  is cross-section area of layer, m<sup>2</sup>;  $j$  is density of the electric current, A/m<sup>2</sup>.

Example: for superconductive wire  $j = 10^{12}$  A/m<sup>2</sup>,  $\gamma_w \approx 10^4$  kg/m<sup>3</sup>,  $i = 10^4$  A the liner mass of superconductive layer is  $m_w = 10^{-4}$  kg/m or 10 kg on 100 km of a wire length,  $s = 10^{-2}$  mm<sup>2</sup>.

**5. Mass of vertical tubes** may be estimated by equation

$$m_v = \gamma_v F_v / \sigma, \quad \text{where} \quad F_v = gq(H)H + q(H)V^2, \quad (8)$$

where  $m_v$  is mass of 1 m vertical tube (wire without superconductive layer and nitrogen), kg/m;  $\gamma_v \approx 1800 \text{ kg/m}^3$  is specific density of tube (artificial fiber or nanotubes);  $F_v$  is force, N;  $\sigma$  is safe tensile stress, N/m<sup>2</sup>;  $q$  is full mass of 1 m tube included the mass of conductor and nitrogen, kg/m;  $H$  is vertical length of wire, m;  $V$  is apparatus speed, m/s;  $g = 9.81 \text{ m/s}^2$  is gravity acceleration. For railgun values  $H = 0$ ,  $q$  may be constant and easy for estimation (see point 7). For space apparatus with high speed and altitude the optimal  $q(H)$  is variable and you must apply the method of successive approximation or others. In other case average  $q = 0.5q(V_m, H_m)$ , where  $V_m, H_m$  are maximal speed and altitude.

Example: For  $F_v = 1000 \text{ N}$ ,  $\gamma = 1800 \text{ kg/m}^3$  and  $\sigma = 200 \text{ kgf/mm}^2 = 2 \cdot 10^9 \text{ N/m}^2$ , the  $m_v = 0.9 \text{ g/m}$ .

**6. Mass of liquid nitrogen** for 1 m wire may be estimated by equation

$$m_n = \gamma_n s_n, \quad (9)$$

where  $\gamma_n = 804 \text{ kg/m}^3$  is specific density of nitrogen;  $s_n$  is cross-section of internal tube, m<sup>2</sup>;

Example: For  $s_n = 1 \text{ mm}^2$ , the  $m_n = 0.8 \text{ g/m}$ .

**7. Total mass of 1 m of wire.** The total mass 1 m of wire is

$$q = m_w + m_v + m_n. \quad (10)$$

If we summarize the above examples, we get about  $q \approx 2 \text{ g/m}$ . For high altitude this value is function of  $H$ .

**8. Mass of an electric coil.** The mass of the superconductive electric force spool (loops) is

$$M_s \approx 3qnd. \quad (11)$$

Example: for  $n = 1000$ ,  $d = 1 \text{ m}$ ,  $q \approx 2 \cdot 10^{-3} \text{ kg/m}$ , the mass one spool is 6 kg.

**9. Total mass of wire.** That is mass of two vertical cable, cooling system, control system, etc.

$$M_c = 2qH + M_s, \quad (12)$$

where  $q$  is linear support mass for height 1 m, kg/m;  $H$  is wire length, m.

Example: for  $q = 0.002 \text{ kg/m}$  and  $H = 10^5 \text{ m} = 100 \text{ km}$  the supported mass is 406 kg. That includes mass of the cooling system by liquid nitrogen. We need it only in altitude 70 – 100 km. Over this altitude no conventional heat transfer is required and a cooling super reflective layer has  $q \approx 0.001 \text{ kg/m}$  or 100 kg on 100 km.

**10. Tensile stress in connection wire.** Limitations on connection wire from acceleration (safety speed and vertical distance for spool design of fig.4) is.

$$F = m_s V = qV^2, \quad \sigma_v = \gamma V^2, \quad \sigma_h = g\gamma H, \quad \sigma = \sigma_v + \sigma_h = \gamma V^2 + g\gamma H, \quad (13)$$

where  $V$  is wire (apparatus) speed, m/s;  $H$  is apparatus altitude, m/s;  $\sigma_v$  is speed stress, N/m<sup>2</sup>;  $\sigma_h$  is altitude stress, N/m<sup>2</sup>;  $\sigma$  is general safety stress, N/m<sup>2</sup>;  $\gamma$  is specific average mass (tube) density, kg/m<sup>3</sup>,  $g = 9.81 \text{ m/s}^2$  is gravity.  $F$  is force, N;  $m_s$  is second mass, kg/s;  $q$  is linear wire mass, kg/m.

Example: For cheap artificial fiber having safety stress  $\sigma = 200 \text{ kgf/mm}^2 = 2 \cdot 10^9 \text{ N/m}^2$ ,  $\gamma \approx 1.8 \cdot 10^3 \text{ kg/m}^3$  the  $V = 1050 \text{ m/s}$ ,  $H = 110 \text{ km}$ . For nanotube having  $\sigma = 10,000 \text{ kgf/mm}^2 = 10^{11} \text{ N/m}^2$ ,  $\gamma \approx 1.8 \cdot 10^3 \text{ kg/m}^3$  the  $V = 7.4 \text{ km/s}$ ,  $H = 5500 \text{ km}$ . Nanotubes are expensive but requested amount is small. The price of nanotubes decreases every year. The limit of  $H$  significantly decreases if accelerate apparatus has an enough horizontal speed because a part of wire losses a weight. The variable cross-section of wire (conic form) can also significantly increases limit of  $H$ .

The mass of wire system usually equals 5 – 15% of a common mass of projectile (accelerated apparatus). That mass may be significantly decreased (by 2 -3 times), if the cross-section of wire is made variable.

**11. Weight of parts of the installation at different altitude.** The weight (and needed support force) of the installation parts is different on different altitude because the gravity acceleration is different and Earth is rotating. This force  $F_w$  [N] is computed by equation:



$$F_w = mg = mg_0 \left[ \left( \frac{R_0}{R} \right)^2 - \frac{\omega R}{g_0} \right], \quad (14)$$

where  $m$  is mass of installation part, kg;  $g_0 = 9.81 \text{ m/s}^2$  is Earth's acceleration;  $R_0 = 6378 \text{ km} = 6.378 \cdot 10^6 \text{ m}$  is Earth radius, m;  $R = R_0 + H$  is radius at the located part, m;  $\omega = 72.685 \cdot 10^{-6} \text{ rad/sec}$  is Earth angle speed, 1/s;  $g$  is Earth gravity (include Earth rotation) at the given altitude,  $\text{m/s}^2$ . Geosynchronous orbit is  $R_g = 42200 \text{ km}$ . At altitude  $H = 0$  the  $F_w \approx mg_0$ , at altitude  $H = R_g - R_0$  the  $F_w \approx 0$ .

- 12. The force required for supporting and vertical accelerating of space apparatus** computes by Eqs. (2), (12) and below:

$$F_c = m(g + a_a), \quad (15)$$

where  $a_a$  is apparatus acceleration,  $\text{m/s}^2$ .

Example: for levitate apparatus having mass  $m = 10,000 \text{ kg}$  and an acceleration  $a_a = g_0 = 10 \text{ m/s}^2$  the force (15) is  $F_c = 2 \cdot 10^5 \text{ N}$  and required an electric current  $i = 5 \cdot 10^3 \text{ A}$  (Eq. (4) for  $n = 1000$ ,  $b = 10$ ).

- 13. Acceleration time and maximal speed.** Trip time  $t$  [s] with constant acceleration equals :

$$t = \sqrt{2S/a_a}, \quad V_{\max} = a_a t, \quad (16)$$

Here  $V_{\max}$  is maximal speed, m/s;  $S$  is distance, m.

Example: for  $S = 100 \text{ km}$ ,  $a_a = 10 \text{ m/s}^2$  the acceleration time is  $t = 141 \text{ sec}$ ,  $V_{\max} = 1410 \text{ m/s}$ ; for  $a_a = 50 \text{ m/s}^2$ ,  $S = 100 \text{ km}$  the  $t \approx 63 \text{ sec}$ ,  $V_{\max} = 3.15 \cdot 10^3 \text{ m/s}$ .

- 14. Needed voltage and power.** Required voltage and power computed by equations

$$U = \frac{\mu_0 n i V}{\pi} \ln \left| \frac{d-a}{a} \right| = \frac{1}{\pi} \mu_0 n i V b, \quad P = iU, \quad (17)$$

where  $U$  is voltage, V;  $V$  is apparatus speed, m/s;  $P$  is power, W. The rest nomenclature is same Eq. (2).

Example: For mass of apparatus  $m = 10 \text{ tons}$ , the electric current  $i = 5 \cdot 10^3 \text{ A}$ ,  $n = 1000$ ,  $b = 10$ , maximal velocity  $V_{\max} = 10^3 \text{ m/s}$  the maximum voltage is  $U_{\max} = 2 \cdot 10^4 \text{ V}$ ; maximal electric power is  $P_{\max} = 10^8 \text{ W}$ .

- 15. The additional energy is needed for unrolling of the magnetic loop.** Inductance  $L_i$  and energy  $E$  of a tower magnetic field are

$$L_i = \frac{\mu_0}{2} \left( 0.5 + \ln \frac{d}{a} \right) S, \quad E_i = \frac{i^2 L_i}{2}, \quad (18)$$

where  $S$  is length of loop, m. The rest nomenclature is same with Eq. (2).

Example: For  $i = 10^4 \text{ A}$ ,  $b = 10$ ,  $S = 100 \text{ km}$ , the  $L_i = 0.66 \text{ H}$ ,  $E_i = 3.3 \cdot 10^7 \text{ J}$ . This energy losses in moment of disconnection projectile from accelerator.

- 16. Efficiency of Railgun and AB-Accelerator.** If we neglect the electric and friction loss in wire, rails and contacts, the efficiency coefficient of Railgun and AB-Accelerator is

$$\eta = \frac{E}{E + E_i}, \quad E = FS, \quad F = \frac{\mu_0 n i^2 b}{\pi}, \quad \eta = \frac{1}{1 + \frac{\pi}{4nb} \left( 0.5 + \ln \frac{d}{a} \right)} \approx \frac{1}{1 + \frac{1,1\pi}{4n}}. \quad (19)$$

As you see the efficiency coefficient of Railgun depends only from  $n$  – number of coil of force spool. For conventional railgun  $n = 1$  and  $\eta = 0.537$ . If we account the electric and friction loss in wire, rails and contacts, the efficiency coefficient of Railgun will be about  $\eta = 0.2 - 0.3$ . The AB-Accelerator has  $n \approx 1000$  and does not have the electric and friction loss in wire, rails and contacts. Its efficiency coefficient is about 0.999. It is in 3 – 5 times more then a conventional railgun or rockets. That is the most efficiency among all known space launchers.

**17. Magnetic intensity in connection wire and spools and magnetic pressure.** Magnetic intensity in vertical wire  $B_w$  and in spool  $B_s$  are computed (estimated) by equations:

$$H_w = \frac{i}{2\pi r_w}, \quad B_w = \mu_0 H_w, \quad B_w = \frac{\mu_0 i}{2\pi r_w}, \quad H_s = \frac{ni}{2r_s}, \quad B_s = \frac{\mu_0 ni}{2r_s}, \quad (20)$$

where  $r_w$  is radius of wire (or tube is outer/inside covered by superconductive layer).m;  $r_s$  is average radius of spool, m.

Example: For  $i = 10^4$  A and internal tube of wire  $r_w = 0.001$  m the  $B_w \approx 2$  T; for spool  $r_s = 1$  m,  $i = 10^3$  A and number of coil revolution  $n = 1000$  the  $B_s = 2\pi = 6.28$  T. Both values are less 100 – 250 T which is safety for superconductive conductor (see Table 1).

The specific magnetic pressure in the wire and spool are

$$p = B^2 / 2\mu_0. \quad (21)$$

Here  $p$  is pressure, N/m<sup>2</sup>, (outer for wire and inside for spool);  $B$  is  $B_w$  or  $B_s$  respectively.

Example: For  $i = 10^4$  A, tube  $r_w = 0.01$  m and  $B_w \approx 0.2$  T the  $p = 1.5 \cdot 10^4$  N/m<sup>2</sup> = 0.15 atm; for spool  $r_s = 1$  m, number of coil revolution  $n = 1000$ ,  $B_s = 2\pi = 6.28$  T the  $p = 3.14 \cdot 10^5$  N/m<sup>2</sup> = 3.14 atm.

**18. Computation of the cooling system.** The following equations allow direct computation of the proposed project cooling systems.

1) Equation of heat balance of a body in vacuum (space)

$$\zeta q s_1 = C_s \varepsilon_a \left( \frac{T}{100} \right)^4 s_2, \quad (22)$$

where  $\zeta = 1 - \xi$  is absorption coefficient of outer radiation,  $\xi$  is reflection coefficient;  $q$  is heat flow, W/m<sup>2</sup> (from Sun at Earth's orbit  $q = 1400$  W/m<sup>2</sup>, from Earth  $q \approx 440$  W/m<sup>2</sup>);  $s_1$  is area under outer radiation, m<sup>2</sup>;  $C_s = 5.67$  W/m<sup>2</sup>K is heat coefficient;  $\varepsilon_a \approx 0.02 \div 0.98$  is blackness coefficient;  $T$  is body temperature, K;  $s_2$  is area of body or screen, m<sup>2</sup>.

Example 1: For good conventional reflective mirror having  $\zeta = 0.05$ ,  $\varepsilon_a \approx 1$ ,  $s_2 = 2 s_1$  the temperature of body under the solar radiation  $q = 1400$  W/m<sup>2</sup> is  $T = 158$  K, under Earth radiation  $q \approx 440$  W/m<sup>2</sup> the  $T = 118$  K. But if we use the special high reflective mirror (cover) proposed by author in [1] Ch. 12 and Ch. 3 in Attn. and having  $\zeta = 10^{-6}$ ,  $\varepsilon_a \approx 1$ ,  $s_2 = 2 s_1$ , the temperature of body (vertical wire) in space (vacuum) under the solar radiation  $q = 1400$  W/m<sup>2</sup> is only  $T = 10.5$  K. That is more than enough for the superconductive wire.

2) Radiation heat flow  $q$  [W/m<sup>2</sup>] between two parallel screens

$$q = C_a \left[ \left( \frac{T_1}{100} \right)^4 - \left( \frac{T_2}{100} \right)^4 \right], \quad C_a = \varepsilon_a C_s, \quad \varepsilon_a = \frac{1}{1/\varepsilon_1 + 1/\varepsilon_2 - 1}, \quad (23)$$

where the lower index  $1, 2$  shows (at  $T$  and  $\varepsilon$ ) the number of screens;  $C_a$  is coerced coefficient of heat transfer between two screens. For bright aluminum foil  $\varepsilon = 0.04 \div 0.06$ . For foil covered by thin bright layer of silver  $\varepsilon = 0.02 \div 0.03$ .

The total amount of the heat flows  $Q$  [J/s] across the cylindrical surface is

$$Q = \frac{1}{1/\varepsilon_1 + (F_2/F_1)(1/\varepsilon_2 - 1)} C_s F_1 \left[ \left( \frac{T_2}{100} \right)^4 - \left( \frac{T_1}{100} \right)^4 \right], \quad (24)$$

where  $F_2$  is area of the outer cylinder, m<sup>2</sup>;  $F_1$  is area of internal cylinder, m<sup>2</sup>.

When we use a vacuum and row ( $n$ ) of the thin screens, the heat flow is

$$q_n = \frac{1}{n+1} \frac{C'_a}{C_a} q, \quad (25)$$

where  $q_n$  is heat flow to protected wire,  $W/m^2$ ;  $C'_a$  is coerced coefficient of heat transfer between wire and the nearest screen,  $C_a$  is coerced coefficient of heat transfer between two near by screens;  $n$  is number of additional screen (revolutions of vacuumed thin foil around central superconductive wire).

Example 1: for  $C'_a = C_a$ ,  $n = 1$ ,  $\varepsilon = 0.05$ ,  $T_1 = 288$  K (15 C, average Earth temperature),  $T_2 = 77.3$  K (liquid nitrogen) we have the  $q_n = 5.7$   $W/m^2$ .

Expense of cooling liquid and power for converting back the vapor into cooling liquid are

$$m_c = q_n / \alpha, \quad M_c = Qt / \alpha, \quad (26)$$

where  $m_c$  is vapor mass of cooling liquid,  $kg/m^2 \cdot sec$ ;  $M_c$  is total mass of cooling liquid in time  $t$  [s],  $J$ ;  $\alpha$  is evaporation heat,  $J/kg$  (see Table 2).

The 100 km loop requires approximately 25 kg/day of liquid nitrogen. If we take more additional screens ( $n > 1$ ), the required cooling is decreased.

- 3) When we use the conventional heat protection, the amount of cool energy, heat flow through cylindrical tube and protection time are computed by equations

$$Q = \alpha \gamma s, \quad P = \frac{2\pi\lambda(T_2 - T_1)}{\ln(d_2 / d_1)}, \quad t = \frac{Q}{P}, \quad (27)$$

where  $Q$  is amount of cooling energy in 1 m of wire,  $J/m$ ;  $P$  is heat flow through cylindrical tube,  $W/m$ ;  $t$  – is cooling time,  $sec$ ;  $\lambda$  - heat conductivity coefficient,  $W/m \cdot K$ . For air  $\lambda = 0.0244$ , for glass-wool  $\lambda = 0.037$ ;  $\alpha$  is heat evaporation,  $kJ/kg$  (Table #2);  $\gamma$  is density of a cooling liquid,  $kg/m^3$  (Table #2);  $s$  cross-section of cooling canal,  $m^2$ ;  $T_2 = 288$  K is outer (air) temperature,  $K$ ;  $T_1 = 77$  K is temperature of nitrogen,  $K$ ;  $d_2$  is outer diameter of wire tube,  $m$ ;  $d_1$  is internal diameter of wire tube,  $m$ ;

Example: For  $d_1 = 1.5$  mm,  $d_2 = 3.5$  mm the cooling time about 1 minute.

The vacuum screening is strong efficiency and light (mass) than the conventional cooling protection.

**Table 2.** Boiling temperature and heat of evaporation of some relevant liquids [18], p.68; [17] p.57.

Liquid	Boiling temperature, K	Heat varoparation, $\alpha$ kJ/kg	Specific density, $kg/m^3$
Hydrogen	20.4	472	67.2
Nitrogen	77.3	197.5	804.3
Air	81	217	980
Oxygen	90.2	213.7	1140
Carbonic acid	194.7	375	1190

**Table 3.** Density, temperature, head conduction, heat capacity, temperature conduction of materials [20], p.351.

	Density $\rho$ $kg/m^3$	Tempe- rature $T$ $^{\circ}C$	Heat con- ductivity $\lambda$ $W/m \cdot K$	Heat capacity $c$ $kJ/kg \cdot K$	Temperature conductivity $a$ $10^6, m^2/s$
Air	1.29	0	0.0244	1.005	18.8
Glass wool	200	0	0.037	0.67	0.278
Miner.wool	200	50	0.0465	0.321	0.258
Cork	200	27	0.0419	1.884	0.117

These data are sufficient for a quick computation of the cooling systems characteristics.

Using the correct design of multi-screens, high-reflectivity mirror or the solar and planetary energy screen, and assuming a hard outer space vacuum between screens, we get a very small heat flow and a very small expenditure for refrigerant (some gram/m<sup>2</sup> per day in Earth). In outer space the protected body can have low temperature without special liquid cooling system ([4], Fig.3).

For example, the space body ([4], Fig. 4a) with innovative prism reflector [1] Ch. 3A ( $\rho = 10^{-6}$ ,  $\varepsilon_a = 0.9$ ) will have temperature about 12 K in outer space. The protection [1], Fig.3b gives more low temperature. The usual multi-screen protection of Fig. 4c gives the temperature: the first screen - 160 K, the second - 75 K, the third - 35 K, the fourth - 16 K.

**19. Cable material.** Let us consider the following experimental and industrial fibers, whiskers, and nanotubes:

Experimental nanotubes CNT (carbon nanotubes) have a tensile strength of 200 Giga-Pascals (20,000 kg/mm<sup>2</sup>). Theoretical limit of nanotubes is 30,000 kg/mm<sup>2</sup>. Young's modulus exceeds a Tera Pascal, specific density  $\gamma = 1800 \text{ kg/m}^3$  (1.8 g/cc) (year 2000).

For safety factor  $n = 2.4$ ,  $\sigma = 8300 \text{ kg/mm}^2 = 8.3 \times 10^{10} \text{ N/m}^2$ ,  $\gamma = 1800 \text{ kg/m}^3$ ,  $(\sigma/\gamma) = 46 \times 10^6$ . The SWNTs nanotubes have a density of 0.8 g/cm<sup>3</sup>, and MWNTs have a density of 1.8 g/cm<sup>3</sup> (average 1.34 g/cm<sup>3</sup>). Unfortunately, even in 2010 CE, nanotubes are very expensive to manufacture. For whiskers  $C_D$   $\sigma = 8000 \text{ kg/mm}^2$ ,  $\gamma = 3500 \text{ kg/m}^3$  (1989) [1], p. 33. Cost about \$400/kg (2001). For industrial fibers  $\sigma = 500 - 600 \text{ kg/mm}^2$ ,  $\gamma = 1800 \text{ kg/m}^3$ ,  $\sigma/\gamma = 2,78 \times 10^6$ . Cost about 2 - 5 \$/kg (2003).

Relevant statistics for some other experimental whiskers and industrial fibers are given in Table 4 below.

**Table 4.** Tensile strength and density of whiskers and fibers

Material	Tensile strength	Density		Tensile strength	Density
Whiskers	kg/mm <sup>2</sup>	g/cm <sup>3</sup>	Fibers	kg/mm <sup>2</sup>	g/cm <sup>3</sup>
AlB <sub>12</sub>	2650	2.6	QC-8805	620	1.95
B	2500	2.3	TM9	600	1.79
B <sub>4</sub> C	2800	2.5	Thorael	565	1.81
TiB <sub>2</sub>	3370	4.5	Alien 1	580	1.56
SiC	2100-4140	3.22	Alien 2	300	0.97
Al oxide	2800-4200	3.96	Kevlar	362	1.44

See Reference [1] p. 33.

**20. Balancing of wire by voltage.** If space station or apparatus spends energy, the vertical wire has voltage. That means they have the different linear electric charges and attract one to other. Let us find the required voltage between them and consumed power.

$$F_3 = \frac{\mu_0}{2\pi d} i^2, \quad F_4 = \frac{1}{2\pi\varepsilon_0} \tau^2. \quad \text{From } F_3 = F_4 \quad \text{we get } \tau = (\mu_0\varepsilon_0)^{0.5} i = \frac{1}{3} 10^{-8} i, \quad (28)$$

where  $R_3$  is a repelling magnetic force, N/m;  $F_4$  is an attractive electrostatic force, N/m;  $\tau$  is a linear electric charge, C/m;  $\varepsilon_0 = 8.85 \cdot 10^{-12}$  is electrostatic constant, F/m;  $i$  is electric current in vertical wire, A.

For equilibrium the voltage  $U$  between the vertical wires and consumed power  $P$  must be

$$U = \int_a^{d-a} E \frac{dl}{l} = \frac{\tau}{2\pi\varepsilon_0} \ln \left| \frac{d-a}{a} \right| = \frac{\tau b}{2\pi\varepsilon_0} = 60bi, \quad P = iU. \quad (29)$$

Example: For  $i = 10^3 \text{ A}$ ,  $b = 3$  the  $U = 1.8 \cdot 10^5 \text{ V}$  and  $P = 1.8 \cdot 10^5 \text{ kW}$ . That value is big and this method of compensation is less suitable.

**21. Profit from space acceleration.** If we increase the initial speed of conventional rocket on  $\Delta V$  the relative payload increases in

$$A = e^{\Delta V/w}, \quad (30)$$

where  $w$  is speed of an exhaust rocket gas, m/s.

Example. If  $\Delta V = 1000$  m/s,  $w = 2500$  m/s the  $A = 1.49 \approx 1.5$ . That is increasing net payload by 50%.

If  $\Delta V = 7000$  m/s,  $w = 2500$  m/s the  $A = 16.4$ . That is increasing net payload by 1640%. A modern medium launcher thus becomes the equivalent of a Saturn V.

## Projects

The most suitable computation for the proposed projects is made in Examples in Theoretical section. That way much data is given without detailed explanation. Our design is not optimal but merely for estimation of the main data.

**Note about using conventional conductors.** The magnetic AB-Accelerator requires high density electric current (about  $10^4 - 10^6$  A/mm<sup>2</sup>) and very low electric resistance. This condition is satisfied only by superconductive wire at the present time. In other cases (with non-superconductive wire) the lift force is less than the wire and AB-spool weight and construction spends very much energy. Unfortunately, the current superconductive material requires a low temperature. Their cooling is made by cheap liquid nitrogen. However the conventional conductor may be used for modeling, research and testing the suspended (levitated) constructions in the development period before a 'flight article' is ready.

### Project 1. AB-Accelerator for warship projectile

The DARPA and NAVY (USA) and UK have a program for the warship railgun capable to accelerate a 2 kg projectile up to speeds of 3 km/s (see end of Introduction). We take the common projectile mass  $m = 10$  kg (9 kg projectile + 1 kg wire system), final speed  $V = 3$  km/s and estimate the parameters of the suggested accelerator.

Let us take the acceleration  $a = 10^4 g = 10^5$  m/s<sup>2</sup>. The requested force is  $F = ma = 10^6$  N, the requested length of wire is  $S = V^2/2a = 45$  m, the acceleration time is  $t = V/a = 0.03$  sec. Kinetic energy of projectile is  $E = mV^2/2 = 4.5 \cdot 10^7$  J. The average power is  $P = E/t = 1.5 \cdot 10^9$  W.

The needed electric current for  $n = 1000$ ,  $b = 10$  (see Eq. (4)) is  $i \approx 1.6 \cdot 10^4$  A. The maximal voltage (Eq.(3)) is  $U_m = 2 \cdot 10^5$  V, The maximal power  $P_m = iU_m = 3.2 \cdot 10^9$  W.

Let us take the distance between vertical wire  $d = 0.1$  m. The repulse force between vertical wire is (Eq.(5)) = 512 N/m.

Let us take the linear wire mass  $q = 0.002$  kg/m. The connection length of wire is 90 m, the force spool wire is 300 m. The total mass complex (together with nitrogen wire is  $M_w = qL = 0.002 \cdot 390 = 0.78$  kg. Let us take the simplest motionless (not rotated) connection spools, (fig. 4a). The maximal tensile stress will be at maximal projectile speed (Eq.(13))  $\sigma = \gamma V^2 = 1800 \cdot 9 \cdot 10^6 = 16.2 \cdot 10^9$  N/m<sup>2</sup> = 1630 kgf/mm<sup>2</sup>. This stress can be withstood only by nanotubes (or whiskers, see Table 2). That is a disadvantage of the AB-Accelerator. But amount of nanotube is small and so is the price if a projectile is not big. If we use the nanotube for cover of the wire we can increase the maximal speed of projectile up 7 km/s (see Theoretical section).

### Project 2. AB-Accelerator for space tourism suborbital rocket

At present time a prospective space tourism suborbital rocket may be lifted by aircraft and started at altitude 8 - 10 km with 'first stage aircraft' speed of 250 m/s . Consider the acceleration for such a conventional rocket which is acceptable for cosmonauts (5 gs).

Let us take the final speed of the accelerator  $V = 1000$  m/s, the acceleration  $a = 5g = 50$  m/s<sup>2</sup>, time of acceleration  $t = 20$  sec. and mass of tourism rocket  $m = 100,000$  kg.

The requested force is  $F = ma = 5 \cdot 10^6$  N, the requested length of wire is  $S = V^2/2a = 10$  km, the Kinetic energy of projectile is  $E = mV^2/2 = 5 \cdot 10^{10}$  J. The average power is  $P = E/t = 2.5 \cdot 10^9$  W.

The needed electric current for  $n = 1000$ ,  $b = 10$  (see Eq. (4)) is  $i = 3.46 \cdot 10^4$  A. The maximal voltage (Eq.(3)) is  $U_m = 1.4 \cdot 10^5$  V, The maximal power  $P_m = iU_m = 5 \cdot 10^9$  W. The average power is  $P = 0.5P_m = 2.5 \cdot 10^9$  W.

Let us take the distance between vertical wires as  $d = 1$  m. The repulse force between vertical wire is (Eq.(5)) = 240 N/m.

Let us take the linear wire mass  $q = 0.003$  kg/m. The connection length of wire is 10,000 m, the force spool wire is 3000 m. The total mass complex (together with nitrogen wire is  $M_w = qL = 0.003 \cdot 23,000 = 69$  kg. Let us take the simplest motionless (not rotated connection spools, fig. 4a). The maximal tensile stress will be at maximal projectile speed and altitude (Eq.(13))  $\sigma = \gamma V^2 + g\gamma H = 2 \cdot 10^9$  N/m<sup>2</sup> = 200 kgf/mm<sup>2</sup>. This stress can be withstood by conventional artificial fiber (see Table 2).

Notice what this has achieved—the space tourism rocket can be a good fraction of 100 tons, the size of a small airliner—and can be maneuvered entirely by a low-maintenance cold gas system—for easy reuse. All the expense of the carrier aircraft and the consumable rocket has been offloaded onto a amortizable AB-Accelerator.

If we use the nanotube for cover of wire we can increase the maximal speed of space ship up 7 km/s (see Theoretical section).

For maximal acceleration speed  $V = 1000$  m/s the payload increases in 50% (without addition from high initial altitude). For acceleration speed  $V = 7000$  m/s the payload increases in 1640% (see Eq.(32)). As noted before, with such a multiplier a medium boost vehicle (~10 tons payload, say a Falcon 9) can become thus the equivalent of a Saturn 5. Even a Falcon 1 (<1 ton payload) can become thus the equivalent of a Falcon 9.

## Conclusion

In this article the author describes new idea, theory and computations for design the new magnetic low cost accelerator for railgun projectile and space apparatus. The suggested design does not have the traditional current rails and sliding contacts. That accelerates the projectile and space apparatus by a magnetic column which can have a length of some kilometers, produces the very high acceleration and the projectile (apparatus) speed up 8 km/s.

Important advantage of the offered design is the lower (up some thousands times) used electric current of high voltage and the very high efficiency coefficient close to 1 (compared with efficiency of the current railgun equal to 20 – 40%). The suggested accelerator may be produced by present technology.

The important advantage of the offered method for space apparatus is following: The method does not need designing new rockets. What is needed is to design only a simple accelerator (accelerate platform). Any current rocket may be installed on this platform and accelerated up high speed and lifted on high altitude before started. That radically increases payload and decreases the cost of launching. The platform (force spool) and wires disconnects from the rocket after acceleration. Platform returns by parachute, the wires reel back to start.

The problems of needed electric energy become far simpler. At first, AB-Accelerator has very high efficiency and spend in 2 – 3 times less energy than a conventional railgun; the second, AB-Accelerator uses the high voltage energy same with voltage the electric stations. That means the power electric station can be directly connected to AB-Accelerator in period of acceleration without expensive transformers and condensers. The power of strong electric plant is enough for launching the rocket (space apparatus) of some hundreds of tons.

The offered magnetic space accelerator is a thousand times cheaper than the well-known cable space elevator. NASA is spending for research of space elevator hundreds of millions of dollars. A small part of this sum is enough for R&D of the magnetic accelerator and make a working model!

The proposed innovation (upper electric AB-spool) allows also solving the problem of the conventional railgun (having the projectile speed 3 -5 km/s). The current conventional railgun uses a very high ampere electric current (millions A) and low voltage. As the result the rails burn. The suggested superconductive AB-spool allows decreases the required electric current by thousands of times (simultaneously the required voltage is increased by the same factor). No rails, therefore no damage to the rails.

Small cheap magnetic prototypes would be easily tested.

The computed projects are not optimal. That is only illustration of an estimation method. The reader can recalculate the AB-Accelerator for his own scenarios (see also [1]-[22]).

## References

(The reader may find some of these articles, at the author's web page: <http://Bolonkin.narod.ru/p65.htm> , in <http://www.scribd.org> , in the WEB of Cornell University <http://arxiv.org> , and in <http://aiaa.org> search term "Bolonkin")

1. Bolonkin A.A., Non-Rocket Space Launch and Flight, Elsevier, 2006, 488 pgs. <http://www.scribd.com/doc/24056182> , <http://Bolonkin.narod.ru/p65.htm> .
2. Bolonkin A.A., New Concepts, Ideas and Innovations in Aerospace, Technology and Human Sciences, NOVA, 2007, 502 pgs. <http://www.scribd.com/doc/24057071> , <http://Bolonkin.narod.ru/p65.htm>
3. Bolonkin A.A., Cathcart R.B., Macro-Projects: Environment and Technology, NOVA, 2008, 537 pgs. <http://www.scribd.com/doc/24057930> . <http://Bolonkin.narod.ru/p65.htm> .
4. Bolonkin A., Magnetic Suspended AB-Structures and Immobile Space Stations, <http://www.scribd.com/doc/25883886>
5. Bolonkin A., Krinker M., Magnetic Space Launcher. Presented as paper AIAA-2009-5261 to 45<sup>th</sup> AIAA Joint Propulsion Conference, 2-5 August 2009, Denver, CO, USA. <http://www.scribd.com/doc/24051286> or <http://aiaa.org> search "Bolonkin".
6. Bolonkin A., Krinker M. , Magnetic Propeller for Uniform Magnetic Field. (Ch.13 . in the book "Macro-Projects: Environment and Technology", NOVA, 2008) <http://www.scribd.com/doc/24057930> . <http://Bolonkin.narod.ru/p65.htm>
7. Bolonkin A.A., Earth Accelerator for Space Ships and Missiles, *JBIS*, Vol. 56, No. 11/12, 2003, pp. 394–404. <http://Bolonkin.narod.ru/p65.htm> .
8. Bolonkin A.A., "Space Cable Launchers", Paper No. 8057 presented at the Symposium "The Next 100 years", Dayton, OH, USA, 14-17 July, 2003. <http://Bolonkin.narod.ru/p65.htm>
9. Bolonkin A.A., Centrifugal Space Launcher, Presented as paper AIAA-2005-4035 at the 41<sup>st</sup> Propulsion Conference, 10-12 July 2005, Tucson, AZ, USA. <http://aiaa.org>, <http://www.scribd.com/doc/24056182> Ch.10.
10. Bolonkin A.A., Electrostatic Linear Engine and Cable Space AB Launcher, Paper AIAA-2006-5229 for 42 Joint Propulsion Conference, Sacramento, USA, 9-12 July, 2006. See also AEAT Vol.78, No.2006, pp. 502-508. <http://aiaa.org>, <http://Bolonkin.narod.ru/p65.htm>
11. Bolonkin A., Krinker M., Magnetic Propeller for Uniform Magnetic Field Levitation <http://arxiv.org/ftp/arxiv/papers/0807/0807.1948.pdf> (12 July, 2008).



12. Bolonkin A., Krinker M.. Magnetic Propeller. Article presented as paper AIAA-2008-4610 to 44th Joint Propulsion Conference, 20-24 July, 2008, Hartford, CT, <http://aiaa.org> .
13. Minovich M., “Electromagnetic Transportation System for Manned Space Travel”, US Patent #4,795,113, January 3, 1989.
14. AIP. Physics Desk References, 3-rd Edition. Springer. 2003.
15. Krinker M., Review of New Concepts, Ideas and Innovations in Space Towers. <http://www.scribd.com/doc/26270139>, <http://arxiv.org/ftp/arxiv/papers/1002/1002.2405.pdf>
16. Galasso F.S., Advanced Fibers and Composite. Gordon and Branch Science Publisher, 1989.
17. Kikoin I.K., Editor. Table of Physical Values, Moscow, 1976, 1007 ps. (in Russian).
18. Koshkin H.I., Shirkevich M.G., Directory of Elementary Physics, Nauka, 1982.
19. Koell D.E., *Handbook of Cost Engineering*, TCS, Germany, 2000.
20. Naschekin V.V., Technical Thermodynamics and Heat Transfer, Moscow, 1969 (in Russian).
21. *Wikipedia*. Some background material in this article is gathered from Wikipedia under the Creative Commons license. <http://wikipedia.org> .
22. <http://NASA-NIAC.narod.ru> , <http://auditing-science.narod.ru>



**MagLev**

## Chapter 11

# Magnetic Suspended AB-Structures and Immobile Space Stations\*

### Abstract

In this chapter the author provides new ideas, theory and computations for building with the current technology low cost magnetic suspended structures and motionless space stations up to 37,000 (geosynchronous orbit) kilometers of altitude. These structures (towers) can be used for launching of spaceships, radio, television, and communication transmissions, for tourism, scientific observation of the Earth's surface, weather of the top atmosphere and military radiolocation. Main idea and attribute of invention is the following: The suspended structures (space station) is supported by a MAGNETIC column which has a mass (weight) close to zero. Author estimates two projects of motionless magnetic space stations: one of height = to 100 km and the second project up to 37000 km (geosynchronous orbit).

These projects are not expensive and do not require a high crane or complex technology. They do require superconductive material and a thin strong film composed of artificial fibers. Both materials are fabricated by current industry. The structures (space stations) can easily be built using present technology without rockets. The construction is built by unreeling of a special roll. Structures (towers) can be used (for communication, tourism, etc.) during the construction process and provide self-financing for further construction. The building does not require work at high altitudes; all construction can be done at the Earth's surface.

The transport system (climber) consists of a very simple magnetic engine provided by electricity from a wire connecting the structure with the Earth.

Problems involving security, control, repair, and stability of the proposed towers are shortly considered. The author is prepared to discuss these and other problems with serious organizations desiring to research and develop this project.

Magnetic towers may also become a civic symbol giving any city a distinctive landmark such as the Eiffel Tower in Paris or the Ostankino Tower in Moscow.

-----  
**Key words:** suspended AB-structure, space tower, magnetic tower, geosynchronous tower, AB towers, motionless satellite, motionless space station.

\* It has been published online 15 December 2010, in the ASCE, **Journal of Aerospace Engineering**(Vol.24,No.1,2011,pp.102-111),

### Introduction

**Brief History.** The idea of building a tower high above the Earth into the heavens is very old [1]. The writings of the revered Moses, about 1450 BC, in Genesis, Chapter 11, refer to an early civilization that in about 2100 BC tried to build a tower to heaven out of brick and tar. This construction was called the Tower of Babel, and was reported to be located in Babylon in ancient Mesopotamia. Later in chapter 28, about 1900 BC, Jacob had a dream about a staircase or ladder built to heaven. This construction was called Jacob's Ladder. More contemporary writings on the subject date back to K.E. Tsiolkovski in his manuscript "Speculation about Earth and Sky and on Vesta," published in 1895 [2-3]. Idea of Space Elevator was suggested and developed by Russian scientist Yuri Artsutanov and was

published in the Sunday supplement of newspaper “Komsomolskaya Pravda” in 1960 [4]. This idea inspired Sir Arthur Clarke to write his novel, *The Fountains of Paradise*, about a Space Elevator located on a fictionalized Sri Lanka, which brought the concept to the attention of the entire world [5].

Today, the world’s tallest construction is a television transmitting tower near Fargo, North Dakota, USA. It stands 629 m high and was built in 1963 for KTHI-TV. The CN Tower in Toronto, Ontario, Canada is the world’s tallest building. It is 553 m in height, was built from 1973 to 1975, and has the world’s highest observation desk at 447 m. The tower structure is concrete up to the observation deck level. Above is a steel structure supporting radio, television, and communication antennas. The total weight of the tower is 130,073 tons.

At present time (2009) the highest structure is Burj Dubai (UAE) having pinnacle height of 822 m, built in 2009 and used for office, hotel, residential.

The Ostankino Tower in Moscow is 540 m in height and has an observation desk at 370 m. The world’s tallest office building is the Petronas Towers in Kuala Lumpur, Malaysia. The twin towers are 452 m in height. They are 10 m taller than the Sears Tower in Chicago, Illinois, USA.

Current materials make it possible even today to construct towers many kilometers in height. However, conventional towers are very expensive, costing tens of billions of dollars. When considering how high a tower can be built, it is important to remember that it can be built to many kilometers of height if the base is large enough.

**The tower’s applications.** High towers (3–100 km) have numerous applications for government and commercial purposes:

- Communication boost: A tower tens of kilometers in height near metropolitan areas could provide much higher signal strength than orbital satellites.
- Low Earth orbit (LEO) communication satellite replacement: Approximately six to ten 100-km-tall towers could provide the coverage of a LEO satellite constellation with higher power, permanence, and easy upgrade capabilities.
- Entertainment and observation desk for tourists. Tourists could see over a huge area, including the darkness of space and the curvature of the Earth’s horizon.
- Drop tower: tourists could experience several minutes of free-fall time. The drop tower could provide a facility for experiments.
- A permanent observatory on a tall tower would be competitive with airborne and orbital platforms for Earth and space observations.
- Solar power receivers: Receivers located on tall towers for future space solar power systems would permit use of higher frequency, wireless, power transmission systems (e.g. lasers).
- Transfer of electric energy from one continent to other continent.

## **Short review of main types of the proposed Space towers**

**1. Solid towers** [6]-[8]. The review of conventional solid high altitude and space towers is in [26]. The first solid space tower was proposed in [2-3]. The optimal solid towers are researched in detail in the series of works [6-8]. These works contain computation of the optimal (minimum weight) solid space towers of up to 40,000 km height. Particularly authors considered solid space tower having the rods filled by light gas as hydrogen or helium. It is shown the solid space tower from conventional material (steel, composites) can be built up to 100-200 km. The GEO tower requires structural diamond.

**2. Inflatable tower** [9]-[12]. The optimal (minimum weight of cover) inflatable towers were researched and computed in [9-12].

The proposed inflatable towers are cheaper by factors of hundreds. They can be built on the Earth's surface and their height can be increased as necessary. Their base is not large. The main innovations in this project are the application of helium, hydrogen, or warm air for filling inflatable structures at high altitude and the solution of a safety and stability problem for tall (thin) inflatable columns, and utilization of new artificial materials, as artificial fiber, whisker and nanotubes.

**3. Circle (centrifugal) Space Towers Tower (Space Keeper) [16 - 17].** The installation includes: a closed-loop cable made from light, strong material (such as artificial fibers, whiskers, filaments, nanotubes, composite material) and a main engine, which rotates the cable at a fast speed in a vertical plane. The centrifugal force makes the closed-loop cable a circle. The cable circle is supported by two pairs (or more) of guide cables, which connect at one end to the cable circle by a sliding connection and at the other end to the planet's surface. The installation has a transport (delivery) system comprising the closed-loop load cables (chains), two end rollers at the top and bottom that can have medium rollers, a load engine and a load. The top end of the transport system is connected to the cable circle by a sliding connection; the lower end is connected to a load motor. The load is connected to the load cable by a sliding control connection.

The Circle tower has many variants.

**4. Kinetic and Cable Space Tower [13-15].** The installation includes: a strong closed-loop cable, rollers, any conventional engine, a space station (top platform), a load elevator, and support stabilization cables (expansions).

The installation works in the following way. The engine rotates the bottom roller and permanently moves the closed-loop cable at high speed. The cable reaches a top roller at high altitude, turns back and moves to the bottom roller. When the cable turns back it creates a reflected (centrifugal) force. This force can easily be calculated using centrifugal theory, or as reflected mass using a reflection (momentum) theory. The force keeps the space station suspended at the top roller; and the cable (or special cabin) allows the delivery of a load to the space station. The station has a parachute that saves the people if the cable or engine fails.

The theory shows, that current widely produced artificial fibers allow the cable to reach altitudes up to 100 km (see Projects 1 and 2 in [14]). If more altitude is required a multi-stage tower must be used (see Project 3 in [14]). If a very high altitude is needed (geosynchronous orbit or more), a very strong cable made from nanotubes must be used (see Project 4 in [14]).

The safety speed of the cable spool is same as the safety speed of the cable because the spool operates as a free roller. The conventional rollers made from the composite cable material have the same safe speed as the cable. The suggested spool is an innovation because it is made only from cable (no core) and it allows reeling up and unreeling simultaneously with different speeds. That is necessary for changing the tower's altitude.

**5. Electrostatic Space Tower [18]-[19].** The proposed electrostatic space tower (or mast, or space elevator) is shown in [18]-[19]. That is an inflatable cylinder (tube) from strong thin dielectric film having variable radius. The film has inside a sectional thin conductive layer 9. Each section is connected with issue of control electric voltages. Interior to the tube there is electron gas from free electrons. The electron gas is separated by sections of a thin partition 11. The layer 9 has a positive charge equals to the sum of negative charges of the inside electrons. The tube (mast) can have length (height) up to Geosynchronous Earth Orbit (GEO, about 36,000 km) or up 120,000 km (and more) as in project (see [18]-[19]). The very high tower allows launching (without spending of energy in launch stage) interplanetary space ships. The proposed optimal tower is designed so that the electron gas in any cross-section area compensates the tube weight and tube does not have compressing longitudinal force from weight. More over the tower has tensile longitudinal (lift) force, which allows the tower a vertical tension (it is held rigid and erect). When the tower has a height more than GEO, the additional centrifugal force of the rotating Earth can lift payloads or be otherwise tapped.

6. **6. Electromagnetic Space Towers (AB-Levitron)** [20]. The AB-Levitron uses two large conductive rings with very high electric current. They create intense magnetic fields. Directions of the electric currents are opposed one to the other and the rings are repelled, one from another. For obtaining enough force over a long distance, the electric current must be very strong. The current superconductive technology allows us to get very high-density electric current and enough artificial magnetic field at a great distance in space. The other type of magnetic tower (magnetic AB-column) is proposed in this article.

The superconductive ring does not spend net electric energy and can work for a long time period, but it requires an integral cooling system because current superconducting materials have a critical temperature of about 150-180 K. This is a cryogenic temperature.

However, the present computations of methods of heat rejection (for example, by liquid nitrogen) are well developed and the induced expenses for such cooling are small.

The ring located in space does not need any conventional cooling—there, defense from Solar and Terrestrial heat radiation is provided by high-reflectivity screens. However, a ring in space must have parts open to outer space for radiating of its heat and support the maintaining of low ambient temperature. For variable direction of radiation, the mechanical screen defense system may be complex. However, there are thin layers of liquid crystals that permit the automatic control of their energy reflectivity and transparency and the useful application of such liquid crystals making it easier for appropriate space cooling system. This effect is used by new man-made glasses that can grow dark in bright solar light.

The most important problem of the AB-Levitron is the stability of the top ring. The top ring is in equilibrium, but it is out of balance when it is not parallel to the ground ring. Author proposes to suspend a load (satellite, space station, equipment, etc) lower than this ring plate. In this case, a center of gravity is lower a net lift force and the system then becomes stable.

For mobile vehicles the AB-Levitron can have a running-wave of magnetic intensity which can move the vehicle (produce electric current), making it significantly mobile in the traveling medium.

**General conclusion.** Current technology can build the high altitude and space towers (masts). We can start an inflatable or steel tower having the height 3 km. This tower is very useful (profitable) for communication, tourism and military. The inflatable tower is significantly cheaper (in ten times) than a steel tower, but it is having a lower life time (up 30-50 years) in comparison to the steel tower having the life times 100 – 200 years. The new advance materials can change this ratio and will make very profitable future high altitude towers.

## **Description of Innovations and Problems**

### **New type of magnetic tower (magnetic AB-column)**

**1. Description of Innovations.** The proposed suspended magnetic structure (tower) is shown in fig. 1. That includes the long vertical loop from electric wire 1 and electric source 6 and connection 15 between the vertical wires. The electric current 2 produces the magnetic field 3 (magnetic column), the magnetic field creates the vertical 4 and horizontal 5 forces. These forces balance the film (or fiber) connection 15. Vertical force 4 supports the useful load at top of the tower and tower construction (wires and film connection).

This design is used in a rail gun [22] but author made many innovations that allow applying this idea to this new application as the magnetic tower and space climber. Some of them are listed following:

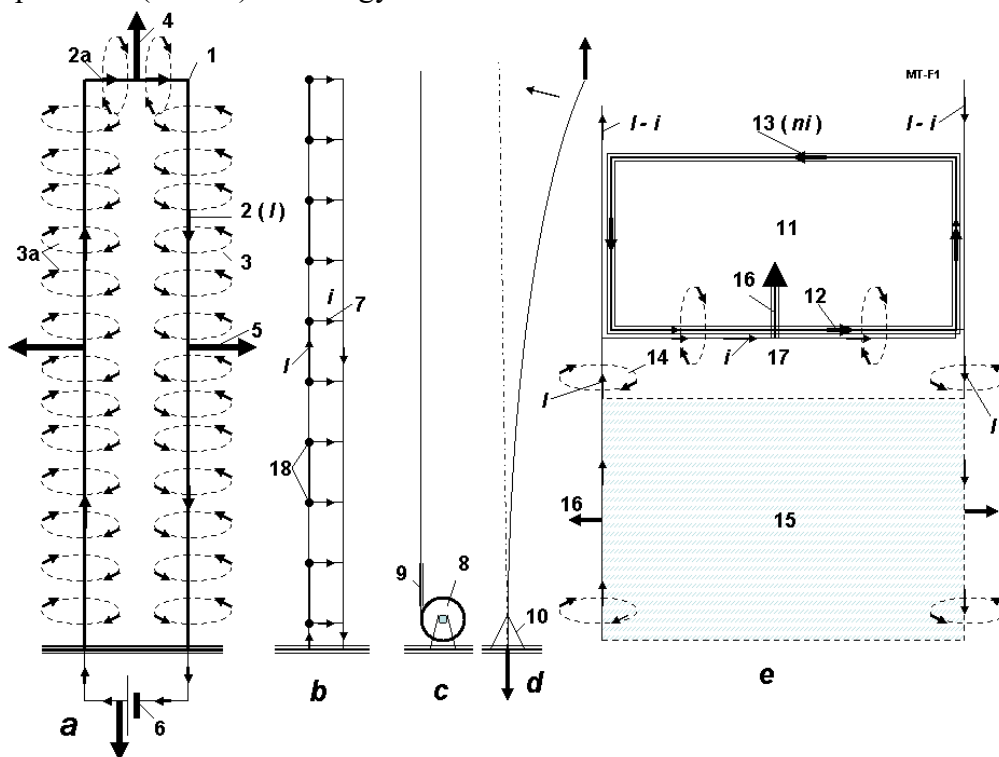
1) The main innovation is a top loop 11 (right angle spool) which increases the number of horizontal wires 12, magnetic intensity in area 17 and lift force 16. We can make a lot of loops up to some thousands and increase the lift force by thousands of times. For a given lift force we can decrease the required current in many times and decreases the mass of source wire 2. That does not necessarily

mean that we decrease the required electric power because the new installation needs a higher voltage. That innovation is very useful also for a space electric climber. The climber engine becomes very simple (horizontal wire or loops). The innovation increases the lift force and decreases sparking (this effect is a very big problem in a rail gun).

The proposed construction creates the MAGNETIC COLUMN 3a that produces a lift force some thousands of times more than a conventional rail gun.

2) The second important innovation is the multi-stage electric loops for the high altitude magnetic tower (for example, a geosynchronous tower)(Fig. 1b).

3) The magnetic towers require superconductive wire, because they need strong electric current (very high specific electric density and conductivity). When we use the superconductive wire, the tower does not need in permanent energy, except in building time and the climber in lifting mode. The climber and construction produces (returns) the energy in descent mode.

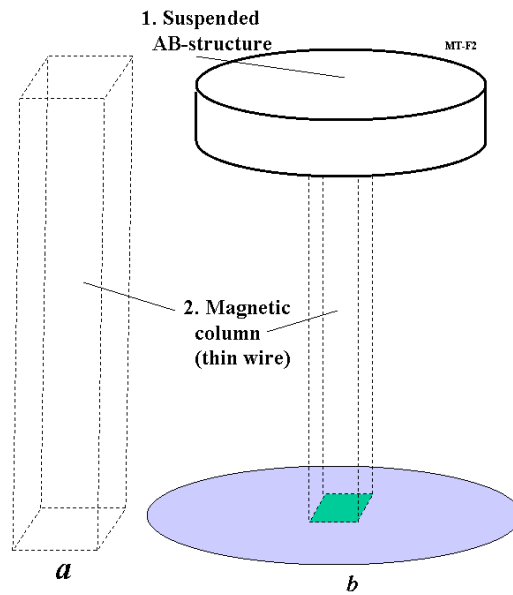


**Fig.1.** Principal sketch of the AB-magnetic tower. *Notations:* (a) One stage magnetic column (tower), (b) – Multi-stage magnetic tower, (c) – building (unreeling) of magnetic tower, (d) – stability of magnetic column, (e) – top part of magnetic tower; 1 – magnetic installation with magnetic column, 2 – vertical wire and direction of electric current  $i$ , 2a – horizontal wire (jumper) and direction of electric current  $i$ , 3 – magnetic field from vertical electric wire, 3a – magnetic column, 4 – magnetic force from horizontal electric wire (jumper), 5 – magnetic force from vertical electric wire, 6 – electric source, 7 – intermediate stage of magnetic column, 8 – tower in roll, 9 – cooling of wire (heat protection) in Earth's atmosphere, 10 – tower braces of magnetic tower in Earth's atmosphere (for better stability), 11 – wire multi-loop spool at top and middle stage or climber (same spool located also on Earth surface), 12 – lower wire of loop (spool), 13 – top wire of loop (spool), 14 – magnetic field from vertical wire, 15 – thin film (it may be transparent) or artificial fiber connected the vertical wire for compensation the magnetic repulse force, 16 – repulse magnetic force, 17 – area strong magnetic field,  $i$  – jumper (horizontal) current,  $ni$  – spool current,  $I$  – current in vertical wire.

**Quadratic magnetic column.** The quadratic four wire magnetic column (Fig.2) is more efficient, stable, safe, reliable and controlled than two wire magnetic column Fig.1. It can curve by remote control (by changing current in vertical wires). It is important for high altitude and geosynchronous

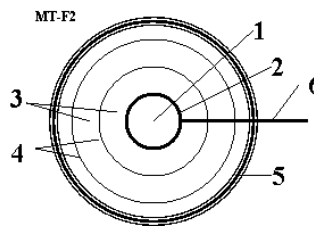
satellites because there is a lot of debris in near Earth outer space. The wire of magnetic column must be protected from damage by space debris.

**2. Cooling system of superconductive wire.** The current superconductive conductor does not spend electric energy and can work for a long time period, but it requires an integral cooling system because the current superconductive materials have the critical temperature of about 100 -180 K (see Table #1 below). The wire located into Earth's atmosphere (up 70 – 100 km) needs cooling.

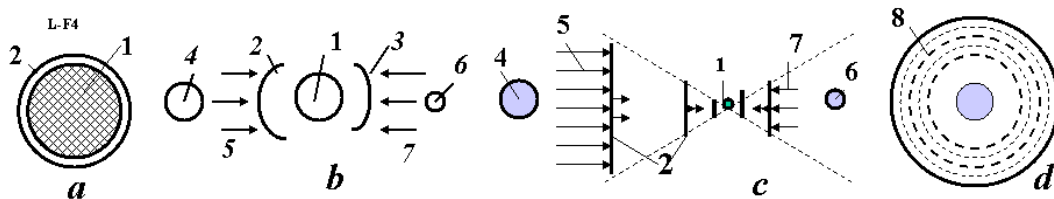


**Fig. 2.** AB-structure is suspended by the almost invisible magnetic columns.

However, the present computational methods of heat rejection are well developed (for example, by liquid nitrogen) and the weight and the induced expenses for cooling are small (fig.2) (see also Computation and Projects sections).



**Fig.3.** Cross-section of superconductive tube. *Notations:* 1 - strong tube (internal part used for cooling of ring, external part is used for superconductive layer; 2 - superconductive layer protected the insulator and heat protection; 3 - vacuum; 4 – heat impact reduction high-reflectivity screens (roll of thin bright aluminum foil); 5 - protection and heat insulation and high reflective layer, 6 – outer electric contact for control system and climber.





**Fig.4.** Methods of cooling (protection from Sun radiation) the superconductive wire in outer space. (a) Protection the wire by the super-reflectivity mirror [13]. (b) Protection by high-reflectivity screen (mirror) from impinging solar and planetary radiations. (c) Protection by usual multi-screens. Notations: 1 - superconductive wires (tybe); 2 - heat protector (super-reflectivity mirror in Fig.4a and a usual mirror in Fig. 4c); 2, 3 – high-reflectivity mirrors (Fig. 4b); 4 - Sun; 5 -Sun radiation, 6 - Earth (planet); 7 - Earth's radiation; 8 – screen with liquid crystals.

The wire located in space does not need any conventional cooling—defense from Sun and Earth radiations are provided by high- reflective layer or high-reflectivity screens (fig.4). However, in last case they must have parts open to outer space for radiating of its heat and support the maintaining of low ambient temperatures. For variable direction of radiation, the mechanical screen defense system may be complex. However, there are thin high reflective layer [13] Ch. 13, 3A or layer from liquid crystals that permits the automatic control of their reflectivity and transparency. The liquid crystals may be used for the space cooling system. This effect is used by new man-made glasses which grow dark in bright solar light.

### 3. Superconductive materials.

There are hundreds of new superconductive materials (type 2) having critical temperature  $70 \div 120$  K and more. *Some of the superconductable materials* are presented in Table 1 (2001). The widely used  $\text{YBa}_2\text{Cu}_3\text{O}_7$  has mass density  $7 \text{ g/cm}^3$ .

**Table 1.** Transition temperature  $T_c$  and upper critical field  $B = H_{c2}(0)$  of some examined superconductors [25 ], p. 752.

Crystal	$T_c$ (K)	$H_{c2}$ (T)
$\text{La}_{2-x}\text{Sr}_x\text{CuO}_4$	38	$\geq 80$
$\text{YBa}_2\text{Cu}_3\text{O}_7$	92	$\geq 150$
$\text{Bi}_2\text{Sr}_2\text{Ca}_2\text{Cu}_3\text{O}_{10}$	110	$\geq 250$
$\text{TlBa}_2\text{Ca}_2\text{Cu}_3\text{O}_9$	110	$\geq 100$
$\text{Tl}_2\text{Ba}_2\text{Ca}_2\text{Cu}_3\text{O}_{10}$	125	$\geq 150$
$\text{HgBa}_2\text{Ca}_2\text{Cu}_3\text{O}_8$	133	$\geq 150$

The last decisions are: Critical temperature is 176 K, up to 183 K. Nanotube has critical temperature of 12 - 15 K,

Some organic matters have a temperature of up to 15 K. Polypropylene, for example, is normally an insulator. In 1985, however, researchers at the Russian Academy of Sciences discovered that as an oxidized thin-film, polypropylene have a conductivity  $10^5$  to  $10^6$  that is higher than the best refined metals.

Boiling temperature of liquid nitrogen is 77.3 K, air 81 K, oxygen 90.2 K, hydrogen 20.4 K, helium 4.2 K [25 ]. Specific density of liquid air is  $920 \text{ kg/m}^3$ , nitrogen  $804 \text{ kg/m}^3$ ; evaporation heat is liquid air is  $213 \text{ kJ/kg}$ , nitrogen  $199 \text{ kJ/kg}$  [28].

Unfortunately, most superconductive material is not strong and needs a strong covering for structural support.

**4. Building of Magnetic Towers.** Building of magnetic tower is simple. Construction of magnetic tower is a thin film which has the superconductive wires in side edges. The wires connect to electric source and the roll is unreel in the top direction.

## 5. Other problems.

**Control system.** The control resistances 18 (fig.1b) located in a jumper connection can change the current  $i$  and control of the magnetic column lift force and bending moment.

**Stability.** If lower surface of magnetic column is horizontal, the vertical magnetic column has a automatic restored moment for any deflection from vertical. The control also can produce a bending moment. The construction can have the guy lines (fig.1d).

**Reliability.** The superconductive wires don't need an electric source. They need only cooling (liquid nitrogen). The magnetic columns have a lot of separated wires. In a case of damage some of them the control system automatically turns on the other wires or passes the current to nearest wires.

The small high altitude construction (motionless satellites) can have a parachute for landing.

**Invisibility of magnetic columns.** The magnetic field invisible, transparent film or fiber, or the vertical thin wires (3 -10 mm) are almost invisible from distance 30 – 100 m and AB-structures will look like bodies suspended in air. This is technically impressive but aircraft warning systems (lights) may be necessary.

## 6. Advantages.

The offer suspended magnetic structures (towers) has big advantages in comparison with other space towers [26]. We compare it with the most popular idea of Space Elevator [11] Chapter 1.

1. Space Elevator is not impossible at present time (2010) for the following reasons:
  - a) No industry production of the very strong and cheap cable material (nanotubes). Nanotubes are very expensive (about \$1000 - \$ 10,000/kg) and are produced in experimental quantities. The space elevator needs thousands of tons of cheap nanotubes.
  - b) Delivery of nanotubes and hundreds tons of equalizer (counterweight) in geosynchronous orbit are very expensive (about \$10,000 – 100,000/kg).
  - c) No climber currently exists which can get energy in a long distance (thousands km) and lifts quickly along the cable.
  - d) Space Elevator costs tens of billions of the USA dollars.
2. The offer magnetic tower has following advantages:
  - a) That can be built from cheap (\$3 – 8/kg) artificial fiber (composite material). Application of a strong material is useful, but not necessary.
  - b) No need to fly in space in building period. All works are made on Earth's surface. The building is very simple (unreeling the roll).
  - c) The climber gets energy from the superconductive cable, it can lift a big load (climber is supported by a self-magnetic column) at any distance and can develop a high speed (particularly once clear of atmosphere)
  - d) Magnetic tower can have any height and be used in a construction mode for other macro-projects.
  - e) Cost of geosynchronous magnetic tower is about only one billion dollars.
  - f) Magnetic tower may be built with current technology.

## 7. Application and further development.

Idea of the magnetic AB-column may be applied to a railgun, to a space launch, to the suspending of houses, buildings, towns, multi-floor cities, to a small flying city-state located over ocean in the international water, (avoiding some of the liabilities of sea-surface communities during storms) to levitating space stations, to communication masts and towers. The may be easily tested in small cheap magnetic constructions for simple projects, on a small scale.

## Theory of Magnetic Towers

**1. Magnetic force acting on horizontal wire.** Proof of magnetic force equation. We use only the well-known physics laws (magnetic force on the electric conductor located into magnetic field):

$$dF = niBdl, \quad B = \mu_0 H, \quad H = \frac{i}{2\pi a}, \quad F = \frac{\mu_0 n i^2}{2\pi} \int_a^{d-a} \frac{1}{l} dl = \frac{\mu_0 n i^2}{2\pi} \ln \left| \frac{d-a}{a} \right|. \quad (1)$$

The force from two vertical wires is

$$F = \frac{\mu_0 n i^2}{\pi} \ln \left| \frac{d-a}{a} \right| = \frac{\mu_0 n i^2 b}{\pi}, \quad \text{where } b = \ln \left| \frac{d-a}{a} \right|, \quad (2)$$

where  $F$  is magnetic force, N;  $n$  is number of wire loops at horizontal connection of one stage or climber (fig.1, #11)(in proposed spool), it may be some thousands;  $\mu_0 = 4\pi \cdot 10^{-7}$  – magnetic constant, H/m;  $d$  is distance between centers of vertical wire, m;  $a$  is radius of wire or thickness of a conductive layer, m;  $b \approx 5 - 10$ ;  $i$  is electric current in the vertical and single horizontal wire, A;  $H$  is magnetic intensity in V/m,  $B$  is in T;  $l$  is distance, m.

The magnetic field acts only on the lower horizontal part of the right-angled spool because the top horizontal part is far from vertical support wire (at top of installation). If spool is located between the vertical wire, the horizontal current  $i = I - (I - i)$  equals the difference of the top and lower parts of the vertical wire separated by point 18 of the connection horizontal wire (jumper) (see Fig. 1b).

The equation (2) without the spool ( $n = 1$ ) is the well-known equation for the rail gun. The proposed innovation (the right-angled spool) increases the force by  $n$  times but simultaneously increases the required voltage also by  $n$  times if the installation changes its size (for example, altitude) or climber moves.

The spool also creates a strong magnetic field but this field acts only on the spool and produces tensile stress into the spool. It easy is compensated for by film, fiber or composed material.

Example: for  $i = 10^4$  A,  $n = 10^3$ ,  $b = 10$  the force is  $F = 4 \cdot 10^5$  N = 40 tons. If  $i = 2 \cdot 10^4$  A, the  $F = 160$  tons. If  $i = 10^5$  A, the  $F = 4000$  tons. Approximately that is the weight of a structure which can be suspended over Earth surface.

The motionless installation using superconductive wires doesn't need maintenance (hovering) energy. If installation is lifting or jumper (climber) is moving, the jumper requires input energy (electric voltage). This voltage and power are computed as below:

$$U = \frac{\mu_0 n i V b}{\pi}, \quad P = iU, \quad (3)$$

where  $V$  is speed of climber or a top jumper of installation, m/s. See the example in point 10 (Climber Power). The spent energy is returned when the installation decreases its altitude or climber descents.

For given force  $F$  the required current is

$$i = \left( \frac{\pi F}{\mu_0 n b} \right)^{0.5}, \quad (4)$$

Example: For  $F = 3000$  N,  $n = 10^3$ ,  $b = 10$  the  $i = 8.7 \cdot 10^2$  A.

**2. Repulse force between the vertical wires.** This force  $F_1$  for wire length of 1 m is

$$F_1 = \frac{\mu_0 i^2}{2\pi d}, \quad (5)$$

Example: for  $i = 10^4$  A,  $d = 2$  m, the force is  $F_1 = 10^3$  N/m = 100 kgf/m.

**3. Massa of film (or fiber) for balance the repulse force** of wire in length 1 m:

$$F_1 = \frac{\mu_0 i^2}{2\pi d}, \quad F_2 = \delta\sigma, \quad F_1 = F_2, \quad m_f = \gamma\delta d, \quad m_f = \frac{\mu_0 \gamma}{2\pi\sigma} i^2, \quad (6)$$

Where  $F_2$  is film (fiber) balance force for length 1 m, N/m;  $\gamma$  is specific mass of film (fiber), kg/m<sup>3</sup>;  $\sigma$  is the safety tensile stress of a film (fiber), N/m<sup>2</sup>;  $\delta$  is thickness of film, m;  $m_f$  is mass of film (fiber), kg/m.

Example: for the current cheap artificial fiber  $\gamma = 1800$  kg/m<sup>3</sup>,  $\sigma = 2 \cdot 10^9$  N/m<sup>2</sup> ( $\sigma = 200$  kgf/mm<sup>2</sup>) (see Table 3),  $i = 10^4$  A the mass  $m_f = 1.8 \cdot 10^{-5}$  kg/m. That is only 2 kg on 100 km of tower height.

**4. Mass of wire.** Mass of two 1 m vertical electric wire is

$$m_w = 2\gamma_w s, \quad s = i/j, \quad m_w = 2\gamma_w i/j, \quad (7)$$

where  $m_w$  is mass of two electric wire of 1 m length, kg/m;  $\gamma_w$  is specific mass of wire kg/m<sup>3</sup>;  $s$  is cross-section area of wire, m<sup>2</sup>;  $j$  is density of the electric current, A/m<sup>2</sup>.

Example: for superconductive wire  $j = 10^{12}$  A/m<sup>2</sup>,  $\gamma_w \approx 10^4$  kg/m<sup>3</sup>,  $i = 10^4$  A the liner mass of superconductive wire is  $m_w = 2 \cdot 10^{-4}$  kg/m or 20 kg on 100 km of a tower height,  $s = 10^{-2}$  mm<sup>2</sup>.

**5. Mass of an electric coil.** The mass of the electric spool (loops)  $m_c$  is

$$m_c \approx 3\gamma_w s n d. \quad (8)$$

Example: for  $n = 1000$ ,  $d = 1$  m,  $\gamma_w \approx 10^4$  kg/m<sup>3</sup>,  $s = 10^{-8}$  m<sup>2</sup> the mass one spool is 0.3 kg.

**6. Linear support mass.** That is mass of two vertical cable, cooling system, control system, etc.

$$m_s = qH, \quad (9)$$

where  $q$  is linear support mass for height 1 m, kg/m;  $H$  is tower (or tower stage) height, m.

Example: for  $q = 0.05$  kg/m and  $H = 10^5$  m = 100 km the supported mass is 5 tons. That is mass of cooling system by liquid nitrogen. We need it only in altitude 70 – 100 km. Over this altitude no conventional heat transfer is required and a cooling super reflective layer has  $q \approx 0.002$  kg/m or 200 kg on 100 km.

**7. Weight of parts of the installation at different altitude.** The weight (and needed support force) of the installation parts is different on different altitude because the gravity acceleration is different and Earth is rotating. This force  $F_w$  [N] is computed by equation:

$$F_w = mg = mg_0 \left[ \left( \frac{R_0}{R} \right)^2 - \frac{\omega R}{g_0} \right], \quad (10)$$

where  $m$  is mass of installation part, kg;  $g_0 = 9.81$  m/s<sup>2</sup> is Earth's acceleration;  $R_0 = 6378$  km =  $6.378 \cdot 10^6$  m is Earth radius, m;  $R = R_0 + H$  is radius at the located part, m;  $\omega = 72.685 \cdot 10^{-6}$  rad/sec is Earth angle speed, 1/s;  $g$  is Earth gravity (include Earth rotation) at the given altitude, m/s<sup>2</sup>.

Geosynchronous orbit is  $R_g = 42200$  km. At altitude  $H = 0$  the  $F_w \approx mg_0$ ,

at altitude  $H = R_g - R_0$  the  $F_w \approx 0$ .

**8. The force required for supporting and accelerating of climber** computes by Eqs. (2),(10) and below:

$$F_c = m(g + a_a), \quad (11)$$

where  $a_a$  is climber acceleration, m/s<sup>2</sup>. Very important fact: the proposed electric climber supports by SELF-magnetic levitation and does transfer its weight and acceleration force to the magnetic tower. That means the climber can have big mass and big acceleration. Climber gets energy from electric wire and its' power does not depend from altitude. Moreover, the climber produces (returns) the energy when one descends to Earth.

Example: for climber having mass  $m = 10,000$  kg and an acceleration  $g = g_0$  the force (11) is  $F_c = 2 \cdot 10^5$  N and required an electric current  $i = 5 \cdot 10^3$  A (Eq. (4) for  $n = 1000$ ,  $b = 10$ ).

**9. Trip time.** Trip time  $t$  [s] equals (include braking) with constant acceleration and braking:

$$t = 2\sqrt{H/a_a}, \quad V_{\max} = 0.5 \cdot a_a t, \quad (12)$$

Here  $V_{\max}$  is maximal speed, m/s;  $H$  is altitude, m.

Example: for  $H = 100$  km,  $a_a = 10$  m/s<sup>2</sup> the trip time is  $t = 200$  sec,  $V_{\max} = 10^3$  m/s; for  $H = 37,000$  km (geosynchronous orbit), the  $t \approx 3$  hours 20 min,  $V_{\max} = 6.1 \cdot 10^4$  m/s.

**10. Climber power.** Required climber voltage and power computed by equations

$$U = \frac{\mu_0 n i V}{\pi} \ln \left| \frac{d-a}{a} \right| = \frac{1}{\pi} \mu_0 n i V b, \quad P = iU, \quad (13)$$

where  $U$  is voltage, V;  $V$  is climber speed, m/s;  $P$  is power, W. The rest nomenclature is same Eq. (2).

Example: For mass of climber  $m = 10$  tons, the electric current  $i = 5 \cdot 10^3$  A,  $n = 1000$ ,  $b = 10$ , maximal velocity  $V_{\max} = 10^3$  m/s the maximum voltage is  $U_{\max} = 2 \cdot 10^4$  V; maximal electric power is  $P_{\max} = 10^8$  W. From other side  $P = FV = 10^5 \cdot 10^3 = 10^8$  W.

**11. The minimal energy is needed for building (unrolling) of the magnetic tower.** Inductance  $L_i$  and energy  $E$  of a tower magnetic field are

$$L_i = \frac{\mu_0}{2} \left( 0.5 + \ln \frac{d}{a} \right) H, \quad E_i = \frac{i^2 L_i}{2}, \quad (14)$$

where  $H$  is tower height, m. The rest nomenclature is same with Eq. (2).

Example: For  $I = 10^4$  A,  $b = 10$ ,  $H = 100$  km, the  $L_i = 0.66$  H,  $E_i = 3.3 \cdot 10^7$  J. For  $H = 37,000$  km the  $L_i = 244$  H,  $E_i = 1.22 \cdot 10^{10}$  J. This energy will be returned in re-rolling of magnetic tower (lowering it, for example for maintenance or during bad meteor storms, close asteroid flybys, space junk intersect alerts)

**12. Magnetic intensity in vertical wire and spool and magnetic pressure.** Magnetic intensity in vertical wire  $B_w$  and in spool  $B_s$  are computed (estimated) by equations:

$$H_w = \frac{i}{2\pi r_w}, \quad B_w = \mu_0 H_w, \quad B_w = \frac{\mu_0 i}{2\pi r_w}, \quad H_s = \frac{n i}{2r_s}, \quad B_s = \frac{\mu_0 n i}{2r_s}, \quad (15)$$

where  $r_w$  is radius of wire (or tube is outer/inside covered by superconductive layer).m;  $r_s$  is radius of spool, m.

Example: For  $I = 10^4$  A and tube (wire)  $r_w = 0.001$  m the  $B_w \approx 2$  T; for spool  $r_s = 1$  m,  $I = 10^3$  A and number of coil revolution  $n = 1000$  the  $B_s = 2\pi = 6.28$  T. Both values are less 100 – 250 T safety for superconductive conductor (see Table 1).

The specific magnetic pressure in the wire and spool are

$$p = B^2 / 2\mu_0. \quad (16)$$

Here  $p$  is pressure, N/m<sup>2</sup>, (outer for wire and inside for spool);  $B$  is  $B_w$  or  $B_s$  respectively.

Example: For  $I = 10^4$  A, tube  $r_w = 0.01$  m and  $B_w \approx 0.2$  T the  $p = 1.5 \cdot 10^4$  N/m<sup>2</sup> = 0.15 atm; for spool  $r_s = 1$  m, number of coil revolution  $n = 1000$ ,  $B_s = 2\pi = 6.28$  T the  $p = 3.14 \cdot 10^5$  N/m<sup>2</sup> = 3.14 atm.

**13. Computation of the cooling system.** The following equations allow direct computation of the proposed macro-project cooling systems.

2) Equation of heat balance of a body in vacuum (space)

$$\zeta q s_1 = C_s \varepsilon_a \left( \frac{T}{100} \right)^4 s_2, \quad (17)$$

where  $\zeta = 1 - \xi$  is absorption coefficient of outer radiation,  $\xi$  is reflection coefficient;  $q$  is heat flow, W/m<sup>2</sup> (from Sun at Earth's orbit  $q = 1400$  W/m<sup>2</sup>, from Earth  $q \approx 440$  W/m<sup>2</sup>);  $s_1$  is area under outer radiation, m<sup>2</sup>;  $C_s = 5.67$  W/m<sup>2</sup>K is heat coefficient;  $\varepsilon_a \approx 0.02 \div 0.98$  is blackness coefficient;  $T$  is body temperature, K;  $s_2$  is area of body or screen, m<sup>2</sup>.

Example 1: For good conventional reflective mirror having  $\zeta = 0.05$ ,  $\varepsilon_a \approx 1$ ,  $s_2 = 2 s_1$  the temperature of body under the solar radiation  $q = 1400$  W/m<sup>2</sup> is  $T = 158$  K, under Earth radiation  $q$

$\approx 440 \text{ W/m}^2$  the  $T = 118 \text{ K}$ . But if we use the special high reflective mirror (cover) proposed by author in [23] Ch. 12 and Ch. 3 in Attn. and having  $\zeta = 10^{-6}$ ,  $\varepsilon_a \approx 1$ ,  $s_2 = 2 s_1$ , the temperature of body (vertical wire) in space (vacuum) under the solar radiation  $q = 1400 \text{ W/m}^2$  is only  $T = 10.5 \text{ K}$ . That is more than enough for the superconductive wire.

2) Radiation heat flow  $q$  [ $\text{W/m}^2$ ] between two parallel screens

$$q = C_a \left[ \left( \frac{T_1}{100} \right)^4 - \left( \frac{T_2}{100} \right)^4 \right], \quad C_a = \varepsilon_a C_s, \quad \varepsilon_a = \frac{1}{1/\varepsilon_1 + 1/\varepsilon_2 - 1}, \quad (18)$$

where the lower index  $1, 2$  shows (at  $T$  and  $\varepsilon$ ) the number of screens;  $C_a$  is coerced coefficient of heat transfer between two screens. For bright aluminum foil  $\varepsilon = 0.04 \div 0.06$ . For foil covered by thin bright layer of silver  $\varepsilon = 0.02 \div 0.03$ .

The total amount of the heat flows  $Q$  [ $\text{J/s}$ ] across the cylindrical surface is

$$Q = \frac{1}{1/\varepsilon_1 + (F_2/F_1)(1/\varepsilon_2 - 1)} C_s F_1 \left[ \left( \frac{T_2}{100} \right)^4 - \left( \frac{T_1}{100} \right)^4 \right], \quad (19)$$

where  $F_2$  is area of the outer cylinder,  $\text{m}^2$ ;  $F_1$  is area of internal cylinder,  $\text{m}^2$ .

When we use a vacuum and row ( $n$ ) of the thin screens, the heat flow is

$$q_n = \frac{1}{n+1} \frac{C'_a}{C_a} q, \quad (20)$$

where  $q_n$  is heat flow to protected wire,  $\text{W/m}^2$ ;  $C'_a$  is coerced coefficient of heat transfer between wire and the nearest screen,  $C_a$  is coerced coefficient of heat transfer between two near by screens;  $n$  is number of additional screen (revolutions of vacuumed thin foil around central superconductive wire).

**Example 1:** for  $C'_a = C_a$ ,  $n = 1$ ,  $\varepsilon = 0.05$ ,  $T_1 = 288 \text{ K}$  (15 C, average Earth temperature),  $T_2 = 77.3 \text{ K}$  (liquid nitrogen) we have the  $q_n = 5.7 \text{ W/m}^2$ .

Expense of cooling liquid and power for converting back the vapor into cooling liquid are

$$m_c = q_n / \alpha, \quad M_c = Qt / \alpha, \quad (21)$$

where  $m_c$  is vapor mass of cooling liquid,  $\text{kg/m}^2 \cdot \text{sec}$ ;  $M_c$  is total mass of cooling liquid in time  $t$  [ $\text{s}$ ],  $J$ ;  $\alpha$  is evaporation heat,  $\text{J/kg}$  (see Table 2).

The 100 km atmospheric part of tower (Example above) requires approximately 4 tons of liquid nitrogen in one day. If we take more additional screens ( $n > 1$ ), the required cooling is decreased.

4) When we use the conventional heat protection, the heat flow is computed by equations

$$q = k(T_1 - T_2), \quad k = \frac{\lambda}{\delta}, \quad (22)$$

where  $k$  is heat transmission coefficient,  $\text{W/m}^2 \cdot \text{K}$ ;  $\lambda$  - heat conductivity coefficient,  $\text{W/m} \cdot \text{K}$ . For air  $\lambda = 0.0244$ , for glass-wool  $\lambda = 0.037$ ;  $\delta$  - thickness of heat protection,  $\text{m}$ .

The vacuum screening is strong efficiency and light (mass) than the conventional cooling protection.

**Table 2.** Boiling temperature and heat of evaporation of some relevant liquids [29], p.68; [28] p.57.

Liquid	Boilng temperature, K	Heat varoparation, $\alpha$ kJ/kg	Specific density, $\text{kg/m}^3$
Hydrogen	20.4	472	67.2
Nitrogen	77.3	197.5	804.3
Air	81	217	980

Oxygen	90.2	213.7	1140
Carbonic acid	194.7	375	1190

These data are sufficient for a quick computation of the cooling systems characteristics.

Using the correct design of multi-screens, high-reflectivity mirror or the solar and planetary energy screen, and assuming a hard outer space vacuum between screens, we get a very small heat flow and a very small expenditure for refrigerant (some gram/m<sup>2</sup> per day in Earth). In outer space the protected body can have low temperature without special liquid cooling system (Fig.3).

For example, the space body (Fig. 4a) with innovative prism reflector [23] Ch. 3A ( $\rho = 10^{-6}$ ,  $\varepsilon_a = 0.9$ ) will have temperature about 12 K in outer space. The protection Fig.3b gives more low temperature. The usual multi-screen protection of Fig. 4c gives the temperature: the first screen - 160 K, the second - 75 K, the third - 35 K, the fourth - 16 K.

**14. Cable material.** Let us consider the following experimental and industrial fibers, whiskers, and nanotubes:

1. Experimental nanotubes CNT (carbon nanotubes) have a tensile strength of 200 Giga-Pascals (20,000 kg/mm<sup>2</sup>). Theoretical limit of nanotubes is 30,000 kg/mm<sup>2</sup>. Young's modulus exceeds a Tera Pascal, specific density  $\gamma = 1800 \text{ kg/m}^3$  (1.8 g/cc) (year 2000).

For safety factor  $n = 2.4$ ,  $\sigma = 8300 \text{ kg/mm}^2 = 8.3 \times 10^{10} \text{ N/m}^2$ ,  $\gamma = 1800 \text{ kg/m}^3$ ,  $(\sigma/\gamma) = 46 \times 10^6$ . The SWNTs nanotubes have a density of 0.8 g/cm<sup>3</sup>, and MWNTs have a density of 1.8 g/cm<sup>3</sup> (average 1.34 g/cm<sup>3</sup>). Unfortunately, even in 2010 CE, nanotubes are very expensive to manufacture.

2. For whiskers  $C_D$   $\sigma = 8000 \text{ kg/mm}^2$ ,  $\gamma = 3500 \text{ kg/m}^3$  (1989) [27, p. 33]. Cost about \$400/kg (2001).
3. For industrial fibers  $\sigma = 500 - 600 \text{ kg/mm}^2$ ,  $\gamma = 1800 \text{ kg/m}^3$ ,  $\sigma/\gamma = 2,78 \times 10^6$ . Cost about 2 - 5 \$/kg (2003).

Relevant statistics for some other experimental whiskers and industrial fibers are given in Table 3 below.

**Table 3.** Tensile strength and density of whiskers and fibers

Material	Tensile strength	Density		Tensile strength	Density
Whiskers	kg/mm <sup>2</sup>	g/cm <sup>3</sup>	Fibers	kg/mm <sup>2</sup>	g/cm <sup>3</sup>
AlB <sub>12</sub>	2650	2.6	QC-8805	620	1.95
B	2500	2.3	TM9	600	1.79
B <sub>4</sub> C	2800	2.5	Thoracl	565	1.81
TiB <sub>2</sub>	3370	4.5	Alien 1	580	1.56
SiC	2100-4140	3.22	Alien 2	300	0.97
Al oxide	2800-4200	3.96	Kevlar	362	1.44

See Reference [23] p. 33.

**15. Balancing of wire by voltage.** If top station or climber spends energy, the vertical wire has voltage. That means they have the different linear electric charges and attract one to other. Let us find the required voltage between them and consumed power.

$$F_3 = \frac{\mu_0}{2\pi d} I^2, \quad F_4 = \frac{1}{2\pi\varepsilon_0} \tau^2. \quad \text{From } F_3 = F_4 \text{ we get } \tau = (\mu_0\varepsilon_0)^{0.5} I = \frac{1}{3} 10^{-8} I, \quad (23)$$

where  $R_3$  is a repel magnetic force, N/m;  $F_4$  is an attractive electrostatic force, N/m;  $\tau$  is a linear electric charge, C/m;  $\varepsilon_0 = 8.85 \cdot 10^{-12}$  is electrostatic constant, F/m;  $I$  is electric current in vertical wire, A.

For equilibrium the voltage  $U$  between the vertical wires and consumed power  $P$  must be



$$U = \int_a^{d-a} E \frac{dl}{l} = \frac{\tau}{2\pi\epsilon_0} \ln \left| \frac{d-a}{a} \right| = \frac{\tau b}{2\pi\epsilon_0} = 60bI, \quad P = IU.$$

**Example:** For  $I = 10^3$  A,  $b = 3$  the  $U = 1.8 \cdot 10^5$  V and  $P = 1.8 \cdot 10^5$  kW. That value is big and this method of compensation is less suitable.

## Projects

The most suitable computation for the proposed projects is made in Examples in Theoretical section. That way much data is given without detailed explanation. Our design is not optimal but merely for estimation of the main data.

**Note about using conventional conductors.** The magnetic AB-column requires the high density electric current (about  $10^4 - 10^6$  A/mm<sup>2</sup>) and very low electric resistance. This condition is satisfied only by superconductive wire at the present time. In other cases (with non-superconductive wire) the lift force is less than the wire and AB-spool weight and construction spends very much energy. Unfortunately, the current superconductive material requires a low temperature. Their cooling is made by cheap liquid nitrogen. However the conventional conductor may be used for modeling, research and testing the suspended (levitated) constructions in the development period before a 'flight article' is ready.

### 1. Motionless 100 km Suspended Magnetic AB-satellite (AB-Magnetic Tower)

(one-stage two wire magnetic tower)

**Lift Force and repulsive force.** For  $I = 10^4$  A,  $n = 10^3$ ,  $b = 10$  the lift force is  $F = 4 \cdot 10^5$  N = 40 tons (Eq. (5)). If  $I = 2 \cdot 10^4$  A, the lift force will be 160 tons. For  $d = 2$  m, the repulse force between the vertical wire is  $F_3 = 10$  N/m = 1 kgf/m (Eq. (5)).

**Mass of film.** For the current cheap artificial fiber having  $\gamma = 1800$  kg/m<sup>3</sup>, safety  $\sigma = 2 \cdot 10^9$  N/m<sup>2</sup> ( $\sigma = 200$  kgf/mm<sup>2</sup>) (see Table 3),  $I = 10^4$  A the film (horizontal fiber) mass  $m_f \approx 2 \cdot 10^{-5}$  kg/m (Eq. (6)). That is only **2** kg for 100 km of tower height.

For superconductive wire having safety electric current density  $j = 10^{12}$  A/m<sup>2</sup>,  $\gamma_w \approx 10^4$  kg/m<sup>3</sup>,  $I = 10^4$  a the liner mass of superconductive wire is  $m_w = 2 \cdot 10^{-4}$  kg/m or **20** kg for 100 km of a tower height, cross section wire area is  $s = 10^{-2}$  mm<sup>2</sup> (Eq.7)) For  $n = 1000$ ,  $d = 1$  m,  $\gamma_w \approx 10^4$  kg/m<sup>3</sup>,  $s = 10^{-8}$  m<sup>2</sup> the mass one spool is **0.3** kg (Eq.(8)).

For specific linear density of double support and cooling cables  $q = 0.05$  kg/m and  $H = 10^5$  m = 100 km the support mass is **5** tons. This mass includes the tube cooling system by nitrogen (nitrogen does not need support). We need cooling tubes only until the altitude 70 – 100 km. Over this altitude no conventional (to air) heat transfer practically occurs and the cooling super reflective layer has  $q \approx 0.002$  kg/m or **200** kg per 100 km.

**Climber.** For climber having mass  $m = 10,000$  kg and an acceleration  $g = g_o$  (1 G vertical) the force (11) is  $F_c = 2 \cdot 10^5$  N and requires an electric current  $i = 5 \cdot 10^3$  A (Eq. (2) for  $n = 1000$ ,  $b = 10$ ). For altitude  $H = 100$  km, acceleration  $a_a = 10$  m/s<sup>2</sup> the trip time is  $t = 200$  sec,  $V_{\max} = 10^3$  m/s. For mass of climber  $m = 10$  tons, the electric current  $i = 5 \cdot 10^3$  A,  $n = 1000$ ,  $b = 10$ , maximal velocity  $V_{\max} = 10^3$  m/s the maximum voltage is  $E_{\max} = 2 \cdot 10^4$  V; maximal electric power is  $N_{\max} = 10^8$  W. This power drain may be greatly reduced by accepting less rocket like accelerations, at the expense of less throughput and longer transit times. It is noteworthy, however, that by using high G forces at less than geostationary heights, in effect we have a 'mass driver' of the G.K. O'Neill sort, that can send (for example) lunar landers to escape velocity, and then slow down the 'bucket' (climber) for recovery and relaunch. This is one way to support a massive space program.

**Minimal energy is needed for building (unrolling) of the magnetic tower.** For  $I = 10^4$  A,  $b = 10$ ,  $H = 100$  km, the inductance is  $L_i = 0.66$  H, and the required energy is  $E_i = 3.3 \cdot 10^7$  J (Eq. (14)).

**Cooling consumption** for support of the superconductive wire in lower (up 100 km) atmospheric part

of magnetic tower is about 2 – 4 tons of liquid nitrogen in one day.

**Summary.** As you see the suggested 100 km magnetic tower (suspended or levitated space station) can keep 34 tons (and in beefed up versions up to 155 tons and more) useful load and has mass of 5022 kg. If this 100 km section is located in vacuum space (over altitude 100 km) it does not need active cooling and has mass of only 222 kg.

## 2. Geosynchronous Magnetic AB-Satellite (AB-Tower)

(multi-stage, two fires tower)

In my opinion the geosynchronous tower must be multi-staged for current material. When we will get the cheap nanotubes and room temperature superconductor we can build the one-stage high altitude magnetic tower.

For estimation the data we assume that one stage has length 100 km. That means the geosynchronous 37000 km tower will has 370 stages. The 100 km stage is not optimal but that allows using the previous computation and data. It is very important that every stage is held by its SELF (its, inherent) magnetic column and doesn't press on lower stage. If stage has enough safety coefficient ( $>2$ ) that can hold the lower stage when it will be out of order or damaged. The stages do **not hold** the space climber because the space climber is supported by its magnetic column. The top stage located on geosynchronous orbit can **hold a big useful mass because this mass has zero weight at GEO** (and extending beyond GEO, useful tension may be added to the tower as a whole, lowering the weight of many stages far toward the ground within the limits of current material strengths.) Thus the payloads can be far bigger, over time, than a simple linear calculation might suggest.

In previous computation we compute that the atmospheric stage has mass  $m_o = 5022$  kg and space stage has  $m_i = 222$  kg. Let us take for reliability  $m_o = 6000$  kg and  $m_i = 300$  kg then **total mass of the geosynchronous magnetic tower will be  $M = m_o + \sum m_i = 16800$  kg.**

The required electric current in every stage is  $i_i = 870$  A (see example in Eq. (2)), the maximal electric current is about  $J = \sum i_i \approx 370 \cdot 8.7 \cdot 10^2 \approx 3.3 \cdot 10^4$  A.

## Conclusion

The research shows that inexpensive levitated magnetic AB-Structures (include LEO motionless and geosynchronous satellites) can be built by the current technology. This significantly (by a thousand times) decreases the cost of space launches. The offered magnetic space tower is a thousand times cheaper than the well-known cable space elevator. NASA is spending for research of space elevator hundreds of millions of dollars. A small part of this sum is enough for R&D of the magnetic tower and make a working model.

The proposed innovation (upper electric AB-spool) allows also solving the problem of the conventional railgun (having projectile speed is 3 -5 km/s). The current conventional railgun uses a very high ampere electric current (millions A) and low voltage. As the result the rails burn. The temporary cooled superconductive AB-spool allows decreases the required electric current by thousands of times (simultaneously the required voltage is increased by the same factor). The damage of rails is decreased.

The same idea may be used in space railgun [27] and space magnetic AB-Launcher without rails, in the suspended structures for communication and so on. The magnetic column may be applied to the suspending houses, buildings, towns, multi-floor cities, to a small state located over ocean in international waters, to the motionless (geostationary or levitating) space stations, to the communication masts and towers. The may be easily tested in small cheap magnetic prototypes with easily available materials on the ground before building the actual article with superconductors . And

the entire assembly can be built on Earth, unlike ‘conventional’ space elevators, for much cheaper deployment.

The climber’s power drain may be greatly reduced by accepting less rocket like accelerations, at the expense of less throughput and longer transit times. It is noteworthy, however, that by using high G forces at less than geostationary heights, that can send (for example) lunar landers or planetary probes to escape velocity, and then slow down the ‘bucket’ (climber) for recovery and relaunch. This is one way to support a massive space program.

The reader can recalculate the levitated installations for his own scenarios. See also [6]-[22],[23],[27].

## References

(Part of these articles the reader can find in author WEB page: <http://Bolonkin.narod.ru/p65.htm>, <http://arxiv.org>, <http://www.scribd.org>, <http://aiaa.org> search term "Bolonkin", and in the books: "Non-Rocket Space Launch and Flight", Elsevier, London, 2006, 488 pgs., "New Concepts, Ideas, and Innovations in Aerospace, Technology and Human Sciences", NOVA, 2007, 502 pgs., "Macro-projects: Environment and Technology", NOVA, 2008, 536, pgs.)

1. Smitherman D.V., Jr., "Space Elevators", NASA/CP-2000-210429.
2. Tsiolkovski K.E., "Speculations about Earth and Sky on Vesta", Moscow, Izd-vo AN SSSR, 1959; Grezi o zemle i nebe (in Russian), Academy of Sciences, USSR., Moscow, p. 35, 1999.
3. Geoffrey A. Landis, Craig Cafarelli, The Tsiolkovski Tower Re-Examined, *JBIS*, Vol. 32, p. 176–180, 1999.
4. Artsutanov Y.. Space Elevator, [http://www.liftport.com/files/Artsutanov\\_Pravda\\_SE.pdf](http://www.liftport.com/files/Artsutanov_Pravda_SE.pdf).
5. Clarke A.C.: *Fountains of Paradise*, Harcourt Brace Jovanovich, New York, 1978.
6. Bolonkin A.A., Optimal Solid Space Tower, Paper AIAA-2006-7717, ATIO Conference, 25-27 Sept.,2006, Wichita, Kansas, USA, <http://arxiv.org/ftp/physics/papers/0701/0701093.pdf> . See also paper AIAA-2006-4235 by A. Bolonkin. <http://aiaa.org> search "Bolonkin".
7. Bolonkin A.A., Optimal Rigid Space Tower, Paper AIAA-2007-367, 45th Aerospace Science Meeting, Reno, Nevada, 8-11 Jan.,2007, USA. <http://aiaa.org> search term "Bolonkin".
8. Bolonkin A.A., "New Concepts, Ideas and Innovation in Aerospace", NOVA, 2008, Ch.9, "Optimal Solid Space Tower", pp.161-172. <http://Bolonkin.narod.ru/p65.htm>, <http://www.scribd.com/doc/24057071>
9. Bolonkin A.A., "Optimal Inflatable Space Towers of High Height", COSPAR-02 C1. 10035-02, 34th Scientific Assembly of the Committee on Space Research (COSPAR). The World Space Congress - 2002, 10 -19 Oct. 2002, Houston, Texas, USA. <http://Bolonkin.narod.ru/p65.htm>
10. Bolonkin A.A., *Optimal Inflatable Space Towers with 3 -100 km Height*", *JBIS*, Vol.56,No.3/4, pp.87-97, 2003. <http://Bolonkin.narod.ru/p65.htm> .
11. Bolonkin A.A., "Non-Rocket Space Launch and Flight", Elsevier. 2006, Ch.4 "Optimal Inflatable Space Towers", pp.83-106; <http://Bolonkin.narod.ru/p65.htm>, <http://www.scribd.com/doc/24056182>
12. Bolonkin A.A., Cathcart R.B., "Macro-Engineering"; Environment and Technology", Ch.1E "Artificial Mountains", pp. 299-334, NOVA, 2008. <http://Bolonkin.narod.ru/p65.htm>, <http://www.scribd.com/doc/24057930>
13. Bolonkin A.A., "Non-Rocket Space Launch and Flight", Elsevier. 2006, Ch. 9 "Kinetic Anti-Gravotator", pp. 165-186, High reflective layer Ch. 12, pp. 223 -244, Ch. 3A, pp. 371-382 ; <http://Bolonkin.narod.ru/p65.htm>, <http://www.scribd.com/doc/24056182> . Main idea of this Chapter was presented as papers COSPAR-02, C1.1-0035-02 and IAC-02-IAA.1.3.03, 53<sup>rd</sup> International Astronautical Congress. The World Space Congress-2002, 10-19 October 2002, Houston, TX, USA, and the full manuscript was accepted as AIAA-2005-4504, 41<sup>st</sup> Propulsion Conference, 10-12 July 2005, Tucson, AZ, USA, <http://aiaa.org> search term "Bolonkin".
14. Bolonkin A.A., "Non-Rocket Space Launch and Flight", Elsevier. 2006, Ch.5 "Kinetic Space Towers", pp. 107-124, Springer, 2006. <http://Bolonkin.narod.ru/p65.htm> or <http://www.scribd.com/doc/24056182> .
15. Bolonkin A.A., "Transport System for Delivery Tourists at Altitude 140 km", manuscript was presented as Bolonkin’s paper IAC-02-IAA.1.3.03 at the World Space Congress-2002, 10-19 October, Houston, TX, USA. <http://Bolonkin.narod.ru/p65.htm> , <http://aiaa.org> search term "Bolonkin".

16. Bolonkin A.A., “*Centrifugal Keeper for Space Station and Satellites*”, JBIS, Vol.56, No. 9/10, 2003, pp. 314-327. <http://Bolonkin.narod.ru/p65.htm> . See also 14 Ch.10, 187 – 208.
17. Bolonkin A.A., "Non-Rocket Space Launch and Flight", Elsevier. 2006, Ch.3 ”*Circle Launcher and Space Keeper*”, pp.59-82. <http://Bolonkin.narod.ru/p65.htm>, <http://www.scribd.com/doc/24056182> .
18. Bolonkin A.A., “*Optimal Electrostatic Space Tower*”, Presented as Paper AIAA-2007-6201 to 43<sup>rd</sup> AIAA Joint Propulsion Conference, 8-11 July 2007, Cincinnati, OH, USA. <http://aiaa.org> search term "Bolonkin". See also “Optimal Electrostatic Space Tower” in: <http://arxiv.org/ftp/arxiv/papers/0704/0704.3466.pdf> .
19. Bolonkin A.A., "New Concepts, Ideas and Innovation in Aerospace", NOVA, 2008, Ch. 11 “*Optimal Electrostatic Space Tower (Mast, New Space Elevator)*”, pp.189-204. <http://Bolonkin.narod.ru/p65.htm>, <http://www.scribd.com/doc/24057071> .
20. Bolonkin A.A., "New Concepts, Ideas and Innovation in Aerospace", NOVA, 2008, Ch.12, pp.205-220 “*AB Levitrons and Their Applications to Earth’s Motionless Satellites*”. (About *Electromagnetic Tower*). <http://Bolonkin.narod.ru/p65.htm> .
21. Book "Macro-Projects: Environment and Technology”, NOVA, 2008, Ch.12, pp.251-270, “*Electronic Tubes and Quasi-Superconductivity at Room Temperature*”, (about *Electronic Towers*). <http://Bolonkin.narod.ru/p65.htm>, <http://www.scribd.com/doc/24057930>
22. Bolonkin A.A., Krinker M., Rail Space Gun. <http://www.scribd.com/doc/24051286>
23. Bolonkin A.A., Non-Rocket Space Launch and Flight, Elsevier, 2006, 488 pgs. <http://www.scribd.com/doc/24056182>
24. Bolonkin A., Krinker M., Magnetic Space Launcher. Presented as paper AIAA-2009-5261 to 45<sup>th</sup> AIAA Joint Propulsion Conference, 2-5 August 2009, Denver, CO, USA. <http://www.scribd.com/doc/24051286> or <http://aiaa.org> search “Bolonkin”.
25. AIP. Physics Desk References, 3-rd Edition. Springer. 2003.
26. Krinker M., Review of New Concepts, Ideas and Innovations in Space Towers. <http://www.scribd.com> search “Krinker”.
27. Galasso F.S., Advanced Fibers and Composite. Gordon and Branch Science Publisher, 1989.
28. Kikoin I.K., Editor. Table of Physical Values, Moscow, 1976, 1007 ps. (in Russian).
29. Koshkin H.I., Shirkevich M.G., Directory of Elementary Physics, Nauka, 1982.

Future suspended structure





Magnetic levitation transport



Current suspended structures



## Chapter 12

# Artificial Explosion of Sun and AB-Criterion for Solar Detonation

### Abstract

The Sun contains ~74% hydrogen by weight. The isotope hydrogen-1 (99.985% of hydrogen in nature) is a usable fuel for fusion thermonuclear reactions.

This reaction runs slowly within the Sun because its temperature is low (relative to the needs of nuclear reactions). If we create higher temperature and density in a limited region of the solar interior, we may be able to produce self-supporting detonation thermonuclear reactions that spread to the full solar volume. This is analogous to the triggering mechanisms in a thermonuclear bomb. Conditions within the bomb can be optimized in a small area to initiate ignition, then spread to a larger area, allowing producing a hydrogen bomb of any power. In the case of the Sun certain targeting practices may greatly increase the chances of an artificial explosion of the Sun. This explosion would annihilate the Earth and the Solar System, as we know them today.

The reader naturally asks: Why even contemplate such a horrible scenario? It is necessary because as thermonuclear and space technology spreads to even the least powerful nations in the centuries ahead, a dying dictator having thermonuclear missile weapons can produce (with some considerable mobilization of his military/industrial complex)—an artificial explosion of the Sun and take into his grave the whole of humanity. It might take tens of thousands of people to make and launch the hardware, but only a very few need know the final targeting data of what might be otherwise a weapon purely thought of (within the dictator's defense industry) as being built for peaceful, deterrent use.

Those concerned about Man's future must know about this possibility and create some protective system—or ascertain on theoretical grounds that it is entirely impossible.

Humanity has fears, justified to greater or lesser degrees, about asteroids, warming of Earthly climate, extinctions, etc. which have very small probability. But all these would leave survivors -- nobody thinks that the terrible annihilation of the Solar System would leave a single person alive. That explosion appears possible at the present time. In this paper is derived the 'AB-Criterion' which shows conditions wherein the artificial explosion of Sun is possible. The author urges detailed investigation and proving or disproving of this rather horrifying possibility, so that it may be dismissed from mind—or defended against.

**Key words:** Artificial explosion of Sun, annihilation of solar system, criterion of nuclear detonation, nuclear detonation wave, detonate Sun, artificial supernova.

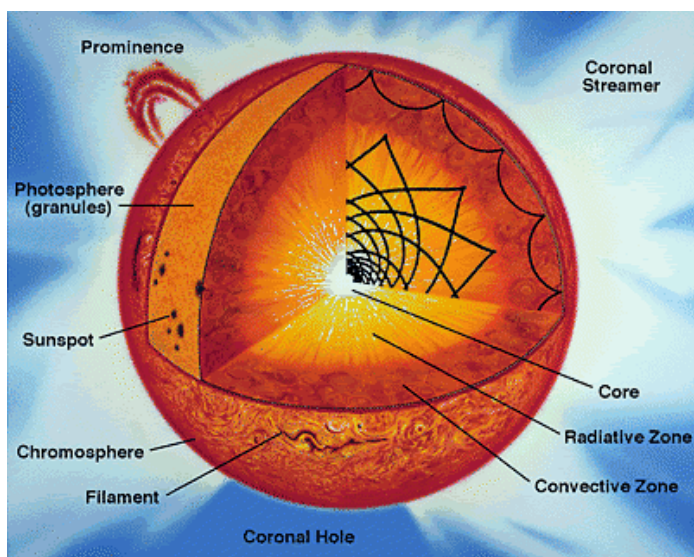
\* This work is written together J. Friedlander. He corrected the author's English, wrote together with author Abstract, Sections 8, 10 ("Penetration into Sun" and "Results"), and wrote Section 11 "Discussion" as the solo author.

## 1. Introduction

**Information about Sun.** The Sun is the star at the center of the Solar System. The Earth and other matter (including other planets, asteroids, meteoroids, comets and dust) orbit the Sun, which by itself accounts for about 99.8% of the solar system's mass. Energy from the Sun—in the form of sunlight—supports almost all life on Earth via photosynthesis, and drives the Earth's climate and weather.

The Sun is composed of hydrogen (about 74% of its mass, or 92% of its volume), helium (about 25%

of mass, 7% of volume), and trace quantities of other elements. The Sun has a spectral class of G2V. G2 implies that it has a surface temperature of approximately 5,500 K (or approximately 9,600 degrees Fahrenheit / 5,315 Celsius).



**Fig.1.** Structure of Sun

Sunlight is the main source of energy to the surface of Earth. The solar constant is the amount of power that the Sun deposits per unit area that is directly exposed to sunlight. The solar constant is equal to approximately 1,370 watts per square meter of area at a distance of one AU from the Sun (that is, on or near Earth). Sunlight on the surface of Earth is attenuated by the Earth's atmosphere so that less power arrives at the surface—closer to 1,000 watts per directly exposed square meter in clear conditions when the Sun is near the zenith.

The Sun is about halfway through its main-sequence evolution, during which nuclear fusion reactions in its core fuse hydrogen into helium. Each second, more than 4 million tonnes of matter are converted into energy within the Sun's core, producing neutrinos and solar radiation; at this rate, the sun will have so far converted around 100 earth-masses of matter into energy. The Sun will spend a total of approximately 10 billion years as a main sequence star.

The core of the Sun is considered to extend from the center to about 0.2 solar radii. It has a density of up to  $150,000 \text{ kg/m}^3$  (150 times the density of water on Earth) and a temperature of close to 13,600,000 kelvins (by contrast, the surface of the Sun is close to 5,785 kelvins ( $1/2350^{\text{th}}$  of the core)). Through most of the Sun's life, energy is produced by nuclear fusion through a series of steps called the *p-p* (proton-proton) chain; this process converts hydrogen into helium. The core is the only location in the Sun that produces an appreciable amount of heat via fusion: the rest of the star is heated by energy that is transferred outward from the core. All of the energy produced by fusion in the core must travel through many successive layers to the solar photosphere before it escapes into space as sunlight or kinetic energy of particles.

About  $3.4 \times 10^{38}$  protons (hydrogen nuclei) are converted into helium nuclei every second (out of about  $\sim 8.9 \times 10^{56}$  total amount of free protons in Sun), releasing energy at the matter-energy conversion rate of 4.26 million tonnes per second, 383 yottawatts ( $383 \times 10^{24} \text{ W}$ ) or  $9.15 \times 10^{10}$  megatons of TNT per second. This corresponds to extremely low rate of energy production in the Sun's core - about  $0.3 \mu\text{W/cm}^3$ , or about  $6 \mu\text{W/kg}$ . For comparison, an ordinary candle produces heat at the rate  $1 \text{ W/cm}^3$ , and human body - at the rate of  $1.2 \text{ W/kg}$ . Use of plasma with similar parameters as solar interior plasma for energy production on Earth is completely impractical - as even a modest 1 GW fusion power plant would require about 170 billion tonnes of plasma occupying almost one cubic mile. Thus all terrestrial



fusion reactors require much higher plasma temperatures than those in Sun's interior to be viable.

The rate of nuclear fusion depends strongly on density (and particularly on temperature), so the fusion rate in the core is in a self-correcting equilibrium: a slightly higher rate of fusion would cause the core to heat up more and expand slightly against the weight of the outer layers, reducing the fusion rate and correcting the perturbation; and a slightly lower rate would cause the core to cool and shrink slightly, increasing the fusion rate and again reverting it to its present level.

The high-energy photons (gamma and X-rays) released in fusion reactions are absorbed in only few millimeters of solar plasma and then re-emitted again in random direction (and at slightly lower energy) - so it takes a long time for radiation to reach the Sun's surface. Estimates of the "photon travel time" range from as much as 50 million years to as little as 17,000 years. After a final trip through the convective outer layer to the transparent "surface" of the photosphere, the photons escape as visible light. Each gamma ray in the Sun's core is converted into several million visible light photons before escaping into space. Neutrinos are also released by the fusion reactions in the core, but unlike photons they very rarely interact with matter, so almost all are able to escape the Sun immediately.

This reaction is very slowly because the solar temperature is very lower of Coulomb barrier.

The Sun's current age, determined using computer models of stellar evolution and nucleocosmochronology, is thought to be about 4.57 billion years.

Astronomers estimate that there are at least 70 sextillion ( $7 \times 10^{22}$ ) stars in the observable universe. That is 230 billion times as many as the 300 billion in the Milky Way.

**Atmosphere of Sun.** The parts of the Sun above the photosphere are referred to collectively as the *solar atmosphere*. They can be viewed with telescopes operating across the electromagnetic spectrum, from radio through visible light to gamma rays, and comprise five principal zones: the *temperature minimum*, the chromosphere, the transition region, the corona, and the heliosphere.

The chromosphere, transition region, and corona are much hotter than the surface of the Sun; the reason why is not yet known. But their density is low.

The coolest layer of the Sun is a temperature minimum region about 500 km above the photosphere, with a temperature of about 4,000 K.

Above the temperature minimum layer is a thin layer about 2,000 km thick, dominated by a spectrum of emission and absorption lines. It is called the *chromosphere* from the Greek root *chroma*, meaning color, because the chromosphere is visible as a colored flash at the beginning and end of total eclipses of the Sun. The temperature in the chromosphere increases gradually with altitude, ranging up to around 100,000 K near the top.

Above the chromosphere is a transition region in which the temperature rises rapidly from around 100,000 K to coronal temperatures closer to one million K. The increase is because of a phase transition as helium within the region becomes fully ionized by the high temperatures. The transition region does not occur at a well-defined altitude. Rather, it forms a kind of nimbus around chromospheric features such as spicules and filaments, and is in constant, chaotic motion. The transition region is not easily visible from Earth's surface, but is readily observable from space by instruments sensitive to the far ultraviolet portion of the spectrum.

The corona is the extended outer atmosphere of the Sun, which is much larger in volume than the Sun itself. The corona merges smoothly with the solar wind that fills the solar system and heliosphere. The low corona, which is very near the surface of the Sun, has a particle density of  $10^{14} \text{ m}^{-3}$ – $10^{16} \text{ m}^{-3}$ . (Earth's atmosphere near sea level has a particle density of about  $2 \times 10^{25} \text{ m}^{-3}$ .) The temperature of the corona is several million kelvin. While no complete theory yet exists to account for the temperature of the corona, at least some of its heat is known to be from magnetic reconnection.

**Physical characteristics of Sun:** Mean diameter is  $1.392 \times 10^6$  km (109 Earths). Volume is  $1.41 \times 10^{18}$  km<sup>3</sup> (1,300,000 Earths). Mass is  $1.988 \times 10^{30}$  kg (332,946 Earths). Average density is 1,408 kg/m<sup>3</sup>. Surface temperature is 5785 K (0.5 eV). Temperature of corona is 5 MK (0.43 keV). Core

temperature is  $\sim 13.6$  MK (1.18 keV). Sun radius is  $R = 696 \times 10^3$  km, solar gravity  $g_c = 274$  m/s<sup>2</sup>. Photospheric composition of Sun (by mass): Hydrogen 73.46 %; Helium 24.85 %; Oxygen 0.77 %; Carbon 0.29 %; Iron 0.16 %; Sulphur 0.12 %; Neon 0.12 %; Nitrogen 0.09 %; Silicon 0.07 %; Magnesium 0.05 %.

Sun photosphere has thickness about  $7 \times 10^{-4} R$  (490 km) of Sun radius  $R$ , average temperature  $5.4 \times 10^3$  K, and average density  $2 \times 10^{-7}$  g/cm<sup>3</sup> ( $n = 1.2 \times 10^{23}$  m<sup>-3</sup>). Sun convection zone has thickness about  $0.15 R$ , average temperature  $0.25 \times 10^6$  K, and average density  $5 \times 10^{-7}$  g/cm<sup>3</sup>. Sun intermediate (radiation) zone has thickness about  $0.6 R$ , average temperature  $4 \times 10^6$  K, and average density  $10$  g/cm<sup>3</sup>. Sun core has thickness about  $0.25 R$ , average temperature  $11 \times 10^6$  K, and average density  $89$  g/cm<sup>3</sup>.

**Detonation** is a process of combustion in which a supersonic shock wave is propagated through a fluid due to an energy release in a reaction zone. This self-sustained detonation wave is different from a deflagration, which propagates at a subsonic rate (i.e., slower than the sound speed in the material itself).

Detonations can be produced by explosives, reactive gaseous mixtures, certain dusts and aerosols.

The simplest theory to predict the behavior of detonations in gases is known as Chapman-Jouguet (CJ) theory, developed around the turn of the 20th century. This theory, described by a relatively simple set of algebraic equations, models the detonation as a propagating shock wave accompanied by exothermic heat release. Such a theory confines the chemistry and diffusive transport processes to an infinitely thin zone.

A more complex theory was advanced during World War II independently by Zel'dovich, von Neumann, and Doering. This theory, now known as ZND theory, admits finite-rate chemical reactions and thus describes a detonation as an infinitely thin shock wave followed by a zone of exothermic chemical reaction. In the reference frame in which the shock is stationary, the flow following the shock is subsonic. Because of this, energy release behind the shock is able to be transported acoustically to the shock for its support. For a self-propagating detonation, the shock relaxes to a speed given by the Chapman-Jouguet condition, which induces the material at the end of the reaction zone to have a locally sonic speed in the reference frame in which the shock is stationary. In effect, all of the chemical energy is harnessed to propagate the shock wave forward.

Both CJ and ZND theories are one-dimensional and steady. However, in the 1960s experiments revealed that gas-phase detonations were most often characterized by unsteady, three-dimensional structures, which can only in an averaged sense be predicted by one-dimensional steady theories. Modern computations are presently making progress in predicting these complex flow fields. Many features can be qualitatively predicted, but the multi-scale nature of the problem makes detailed quantitative predictions very difficult.

## 2. Statement of Problem, Main Idea and Our Aim

The present solar temperature is far lower than needed for propagating a runaway thermonuclear reaction. In Sun core the temperature is only  $\sim 13.6$  MK (0.0012 MeV). The Coulomb barrier for protons (hydrogen) is more than 0.4 MeV. Only very small proportions of core protons take part in the thermonuclear reaction (they use a tunnelling effect). Their energy is in balance with energy emitted by Sun for the Sun surface temperature 5785 K (0.5 eV).

We want to clarify: If we create a zone of limited size with a high temperature capable of overcoming the Coulomb barrier (for example by insertion of a thermonuclear warhead) into the solar photosphere (or lower), can this zone ignite the Sun's photosphere (ignite the Sun's full load of thermonuclear fuel)? Can this zone self-support progressive runaway reaction propagation for a significant proportion of the available thermonuclear fuel?

If it is possible, researchers can investigate the problems: What will be the new solar temperature? Will this be metastable, decay or runaway? How long will the transformed Sun live, if only a minor change? What the conditions will be on the Earth?

Why is this needed?

As thermonuclear and space technology spreads to even the least powerful nations in the decades and centuries ahead, a dying dictator having thermonuclear weapons and space launchers can produce (with some considerable mobilization of his military/industrial complex)—the artificial explosion of the Sun and take into his grave the whole of humanity.

It might take tens of thousands of people to make and launch the hardware, but only a very few need know the final targeting data of what might be otherwise a weapon purely thought of (within the dictator's defense industry) as being built for peaceful, 'business as usual' deterrent use. Given the hideous history of dictators in the twentieth century and their ability to kill technicians who had outlived their use (as well as major sections of entire populations also no longer deemed useful) we may assume that such ruthlessness is possible.

Given the spread of suicide warfare and self-immolation as a desired value in many states, (in several cultures—think Berlin or Tokyo 1945, New York 2001, Tamil regions of Sri Lanka 2006) what might obtain a century hence? All that is needed is a supportive, obedient defense complex, a 'romantic' conception of mass death as an ideal—even a religious ideal—and the realization that his own days at power are at a likely end. It might even be launched as a trump card in some (to us) crazy internal power struggle, and plunged into the Sun and detonated in a mood of spite by the losing side. '*Burn baby burn*'!

A small increase of the average Earth's temperature over 0.4 K in the course of a century created a panic in humanity over the future temperature of the Earth, resulting in the Kyoto Protocol. Some stars with active thermonuclear reactions have temperatures of up to 30,000 K. If not an explosion but an enhanced burn results the Sun might radically increase in luminosity for—say—a few hundred years. This would suffice for an average Earth temperature of hundreds of degrees over 0 C. The oceans would evaporate and Earth would bake in a Venus like greenhouse, or even lose its' atmosphere entirely.

Thus we must study this problem to find methods of defense from human induced Armageddon. The interested reader may find needed information in [1]-[4].

### 3. Theory and estimations

**1. Coulomb barrier (repulsion).** Energy is needed for thermonuclear reaction may be computed by equations

$$E = \frac{kZ_1Z_2e^2}{r} = 2.3 \cdot 10^{-28} \frac{Z_1Z_2}{r} [J] \quad \text{or} \quad E = \frac{kZ_1Z_2e}{r} = 1.44 \cdot 10^{-9} \frac{Z_1Z_2}{r} [eV], \quad (1)$$

$$\text{where } r = r_1 + r_2, \quad r_i = (1.2 \div 1.5) \times 10^{-15} \sqrt[3]{A_i}$$

where  $E$  is energy needed for forcing contact between two nuclei, J or eV;  $k = 9 \times 10^9$  is electrostatic constant,  $\text{Nm}^2/\text{C}^2$ ;  $Z$  is charge state;  $e = 1.6 \times 10^{-19}$  is charge of proton, C;  $r$  is distance between nucleus centers, m;  $r_i$  is radius of nucleus, m;  $A = Z + N$  is nuclei number,  $N$  is number neutrons into given ( $i = 1, 2$ ) nucleus.

The computations of average temperature (energy) for some nucleus are presented in Table #1 below. We assume that the first nucleus is moving; the second (target) nucleus is motionless.

**Table 1.** Columb barrier of some nuclei pairs.

Reaction	$E$ , MeV	Reaction	$E$ , MeV	Reaction	$E$ , MeV	Reaction	$E$ , MeV
p + p	0.53	T+p	0.44	<sup>6</sup> L+p	1.13	<sup>13</sup> C+p	1.9
D + p	0.47	D+d	0.42	<sup>7</sup> Be+p	1.5	<sup>12</sup> C+ <sup>4</sup> He	3.24

In reality the temperature of plasma may be significantly lower than in table 1 because the nuclei have different velocity. Parts of them have higher velocity (see Maxwell distribution of nuclei speed in plasma), some of the nuclei do not (their energy are summarized), and there are tunnel effects. If the temperature is significantly lower, then only a small part of the nuclei took part in reaction and the fuel burns very slowly. This case we have--happily in the present day Sun where the temperature in core has only 0.0012 MeV and the Sun can burn at this rate for billions of years.

The ratio between temperatures in eV and in K is

$$T_K = 1.16 \times 10^4 T_e, \quad T_e = 0.86 \times 10^{-4} T_K. \quad (2)$$

**2. The energy of a nuclear reaction.** The energy and momentum conservation laws define the energetic relationships for a nuclear reaction [1]-[2].

When a reaction  $A(a,b)B$  occurs, the quantity

$$Q = [(M_A + M_a) - (M_B + M_b)]c^2, \quad (3)$$

where  $M_i$  are the masses of the particles participating in the reaction and  $c$  is the speed of light,  $Q$  is the reaction energy.

Usually *mass defects*  $\Delta M$  are used, instead of masses, for computing  $Q$ :

$$Q = (\Delta M_A + \Delta M_a) - (\Delta M_B + \Delta M_b). \quad (4)$$

The mass defect is the quantity  $\Delta M = M - A$  where  $M$  is the actual mass of the particle (atom),  $A$  is the so-called mass number, i.e. the total number of nucleons (protons and neutrons) in the atomic nucleus. If  $M$  is expressed in atomic mass units (a.m.u.) and  $A$  is assigned the same unit, then  $\Delta M$  is also expressed in a.m.u. One a.m.u. represent 1/12 of the <sup>12</sup>C nuclide mass and equals  $1.6605655 \times 10^{-27}$  kg. For calculations of reaction energies it is more convenient to express  $\Delta M$  in kilo-electronvolts: a.m.u. = 931501.59 keV.

Employing the mass defects, one can handle numbers that are many times smaller than the nuclear masses or the binding energies.

Kinetic energy may be released during the course of a reaction (exothermic reaction) or kinetic energy may have to be supplied for the reaction to take place (endothermic reaction). This can be calculated by reference to a table of very accurate particle rest masses (see <http://physics.nist.gov/PhysRefData/Compositions/index.html>). The reaction energy (the "Q-value") is positive for exothermal reactions and negative for endothermal reactions.

The other method calculate of thermonuclear energy is in [1]. For a nucleus of atomic number  $Z$ , mass number  $A$ , and Atomic mass  $M(Z,A)$ , the binding energy is

$$Q = [ZM(^1H) + (A - Z)m_n - M(Z, A)]c^2, \quad (5)$$

where  $M(^1H)$  is mass of a hydrogen atom and  $m_n$  is mass of neutron. This equation neglects a small correction due to the binding energy of the atomic electrons.

The binding energy per nucleus  $Q/A$ , varies only slightly in the range of 7 - 9 MeV for nuclei with  $A > 12$ .

The binding energy can be approximately calculated from Weizsacker's semiempirical formula:

$$Q = a_v A - a_s A^{2/3} - a_c Z(Z - 1)A^{-1/3} - a_{sym} (A - 2Z)^2 / A + \delta, \quad (6)$$

where  $\delta$  accounts for pairing of like nucleons and has the value  $+a_p A^{-3/4}$  for  $Z$  and  $N$  both even,  $-a_p A^{-3/4}$  for  $Z$  and  $N$  both odd, and zero otherwise ( $A$  odd). The constants in this formula must be adjusted for the best agreement with data: typical value are  $a_v = 15.5$  MeV,  $a_s = 16.8$  MeV,  $a_c = 0.72$  MeV,  $a_{sym} =$

23 MeV, and  $a_p = 34$  MeV.

The binding energy per nucleon of the helium-4 nucleus is unusually high, because the He-4 nucleus is doubly magic. (The He-4 nucleus is unusually stable and tightly-bound for the same reason that the helium atom is inert: each pair of protons and neutrons in He-4 occupies a filled **1s** nuclear orbital in the same way that the pair of electrons in the helium atom occupies a filled **1s** electron orbital). Consequently, alpha particles appear frequently on the right hand side of nuclear reactions.

The energy released in a nuclear reaction can appear mainly in one of three ways:

- kinetic energy of the product particles
- emission of very high energy photons, called gamma rays
- some energy may remain in the nucleus, as a metastable energy level.

When the product nucleus is metastable, this is indicated by placing an asterisk ("\*") next to its atomic number. This energy is eventually released through nuclear decay.

If the reaction equation is balanced, that does not mean that the reaction really occurs. The rate at which reactions occur depends on the particle energy, the particle flux and the reaction cross section.

In the initial collision which begins the reaction, the particles must approach closely enough so that the short range strong force can affect them. As most common nuclear particles are positively charged, this means they must overcome considerable electrostatic repulsion before the reaction can begin. Even if the target nucleus is part of a neutral atom, the other particle must penetrate well beyond the electron cloud and closely approach the nucleus, which is positively charged. Thus, such particles must be first accelerated to high energy, for example by very high temperatures, on the order of millions of degrees, producing thermonuclear reactions

Also, since the force of repulsion is proportional to the product of the two charges, reactions between heavy nuclei are rarer, and require higher initiating energy, than those between a heavy and light nucleus; while reactions between two light nuclei are commoner still.

Neutrons, on the other hand, have no electric charge to cause repulsion, and are able to effect a nuclear reaction at very low energies. In fact at extremely low particle energies (corresponding, say, to thermal equilibrium at room temperature), the neutron's de Broglie wavelength is greatly increased, possibly greatly increasing its capture cross section, at energies close to resonances of the nuclei involved. Thus low energy neutrons *may* be even more reactive than high energy neutrons.

**Table 2.** Exothermic thermonuclear reactions.

№	Reaction	Energy of reaction MeV	$\sigma_{\max}$ barn $E \leq 1$ MeV	$E$ of $\sigma_{\max}$ MeV	№	Reaction MeV	Energy of reaction MeV	$\sigma_{\max}$ barn $E \leq 1$ MeV	$E$ of $\sigma_{\max}$ MeV
1	$p+p \rightarrow d+e^++\nu$	2.2	$10^{-23}$	-	15	$d+{}^6\text{Li} \rightarrow {}^7\text{Li}+p$	5.0	0.01	1
2	$p+d \rightarrow {}^3\text{He}+\gamma$	5.5	$10^{-6}$	-	16	$d+{}^6\text{Li} \rightarrow 2{}^4\text{He}$	22.4	0.026	0.60
3	$p+t \rightarrow {}^4\text{He}+\gamma$	19.7	$10^{-6}$	-	17	$d+{}^7\text{Li} \rightarrow 2{}^4\text{He}+n$	15.0	$10^{-3}$	0.2
4	$d+d \rightarrow t+p$	4.0	0.16	2	18	$p+{}^9\text{Be} \rightarrow 2{}^4\text{He}+d$	0.56	0.46	0.33
5	$d+d \rightarrow {}^3\text{He}+n$	3.3	0.09	1	19	$p+{}^9\text{Be} \rightarrow {}^6\text{Li}+{}^4\text{He}$	2.1	0.34	0.33
6	$d+d \rightarrow {}^4\text{He}+\gamma$	24	-	-	20	$p+{}^{11}\text{B} \rightarrow 3{}^4\text{He}$	8.7	0.6	0.675
7	$d+t \rightarrow {}^4\text{He}+n$	17.6	5	0.13	21	$p+{}^{15}\text{N} \rightarrow {}^{12}\text{C}+{}^4\text{He}$	5.0	0.6	1.2
8	$t+d \rightarrow {}^4\text{He}+n$	17.6	5	0.195	22	$d+{}^6\text{Li} \rightarrow {}^7\text{Be}+n$	3.4	0.01	0.3
9	$t+t \rightarrow {}^4\text{He}+2n$	11.3	0.1	1	23	${}^3\text{He}+t \rightarrow {}^4\text{He}+d$	14.31	0.7	$\approx 1$
10	$d+{}^3\text{He} \rightarrow {}^4\text{He}+p$	18.4	0.71	0.47	24	${}^3\text{H}+{}^4\text{He} \rightarrow {}^7\text{Li}+\gamma$	2.457	$7 \cdot 10^{-5}$	$\approx 3$
11	${}^3\text{He}+{}^3\text{He} \rightarrow {}^4\text{He}+2p$	12.8	-	-	25	${}^3\text{H}+d \rightarrow {}^4\text{He}$	17.59	$5 \cdot 10^{-4}$	$\approx 2$

12	$n+{}^6\text{Li}\rightarrow{}^4\text{He}+t$	4,8	2.6	0.26	26	${}^{12}\text{C}+p\rightarrow{}^{13}\text{N}+\gamma$	1.944	$10^{-6}$	0.46
13	$p+{}^6\text{Li}\rightarrow{}^4\text{He}+{}^3\text{He}$	4,0	$10^{-4}$	0.3	27	${}^{13}\text{C}+p\rightarrow{}^{14}\text{N}+\gamma$	7.55	$10^{-4}$	0.555
14	$p+{}^7\text{Li}\rightarrow{}^2{}^4\text{He}+\gamma$	17.3	$6\cdot 10^{-3}$	0.44	28	${}^3\text{He}+{}^4\text{He}\rightarrow{}^7\text{Be}+\gamma$	1.587	$10^{-6}$	$\approx 8$

Here are: p (or  ${}^1\text{H}$ ) - proton, d (or D, or  ${}^2\text{H}$ ) - deuterium, t (or T, or  ${}^3\text{H}$ ) - tritium, n - neutron, He - helium, Li - lithium, Be - beryllium, B - barium, C - carbon, N - hydrogen,  $\nu$  - neutrino,  $\gamma$  - gamma radiation.

**3. Distribution of thermonuclear energy between particles.** In most cases the result of thermonuclear reaction is more than one product. As you see in Table 2 that may be "He" and neutron or proton. The thermonuclear energy distributes between them in the following manner:

$$\text{From } E = E_1 + E_2 = \frac{m_1 V_1^2}{2} + \frac{m_2 V_2^2}{2}, \quad m_1 V_1 = m_2 V_2, \quad (7)$$

$$\text{we have } \frac{E_1}{E} = \frac{m_2}{m_1 + m_2} = \frac{\mu_2}{\mu_1 + \mu_2}, \quad E_2 = E - E_1$$

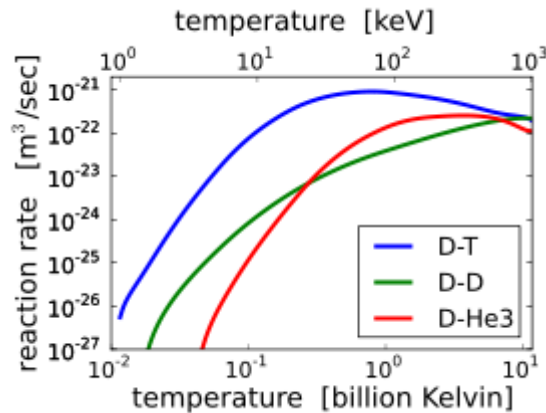
where  $m$  is particle mass, kg;  $V$  is particle speed, m/s;  $E$  is particle energy, J;  $\mu = m_i/m_p$  is relative particle mass. Lower indexes "1,2" are number of particles.

After some collisions the energy  $E = kT$  (temperature) of different particles may be closed to equal.

**4. The power density produced in thermonuclear reaction** may be computed by the equation

$$P = E n_1 n_2 \langle \sigma v \rangle, \quad (8)$$

where  $E$  is energy of single reaction, eV or J;  $n_1$  is density (number particles in  $\text{cm}^3$ ) the first component;  $n_2$  is density (number particles in  $\text{cm}^3$ ) the second component;  $\langle \sigma v \rangle$  is reaction rate, in  $\text{cm}^3/\text{s}$ ;  $\sigma$  is cross section of reaction,  $\text{cm}^2$ , 1 barn =  $10^{-24} \text{cm}^2$ ;  $v$  is speed of the first component, cm/s;  $P$  is power density, eV/ $\text{cm}^3$  or J/ $\text{cm}^3$ . Cross section of reaction before  $\sigma_{max}$  very strongly depends from temperature and it is obtainable by experiment. They can have the maximum resonance. For very high temperatures the  $\sigma$  may be close to the nuclear diameter.



**Fig.2.** Reaction rate  $\langle \sigma v \rangle$  via plasma temperature for D-T (top), D-D (middle) and D- ${}^3\text{He}$  (bottom in left side).

The terminal velocity of the reaction components (electron and ions) are

$$v_{Te} = (kT_e / m_e)^{1/2} = 4.19 \times 10^7 T_e^{1/2}. \quad \text{cm} / \text{s}, \quad (9)$$

$$v_{Ti} = (kT_i / m_i)^{1/2} = 9.79 \times 10^7 (T_i / \mu_i)^{1/2}. \quad \text{cm} / \text{s}, \quad (10)$$

where  $T$  is temperature in eV;  $\mu_i = m_i/m_p$  is ratio of ion mass to proton mass.

The sound velocity of ions is

$$v = \left( \frac{\gamma z k T_k}{m_i} \right)^{1/2}, \quad (11)$$

where  $\gamma \approx (1.2 \div 1.4)$  is adiabatic coefficient;  $z$  is number of charge ( $z = 1$  for  $p$ ),  $T_k$  is plasma temperature in K;  $m_i$  is mass of ion.

The deep of penetration of outer radiation into plasma is

$$d = 5.31 \cdot 10^5 n_e^{-1/3}, \quad [cm]$$

where  $n_e$  is number of electrons in unit of volume.

In internal plasma detonation there is no loss in radiation because the plasma reflects the radiation.

## 4. Possible Thermonuclear Reactions to Power a Hypothetical Solar Explosion

The Sun mass is ~74% hydrogen and 25% helium.

Possibilities exist for the following self-supporting nuclear reactions in the hydrogen medium: proton chain reaction, CNO cycle, Triple-alpha process, Carbon burning process, Neon burning process, Oxygen burning process, Silicon burning process.

For our case of particular interest (a most probable candidate) the proton-proton chain reaction. It is more exactly the reaction  $p + p$ .

**The proton-proton chain reaction** is one of several fusion reactions by which stars convert hydrogen to helium, the primary alternative being the CNO cycle. The proton-proton chain dominates in stars the size of the Sun or less.

The first step involves the fusion of two hydrogen nuclei  ${}^1\text{H}$  (protons) into deuterium  ${}^2\text{H}$ , releasing a positron and a neutrino as one proton changes into a neutron.



with the neutrinos released in this step carrying energies up to 0.42 MeV.

The positron immediately annihilates with an electron, and their mass energy is carried off by two gamma ray photons.

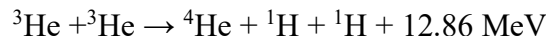


After this, the deuterium produced in the first stage can fuse with another hydrogen to produce a light isotope of helium,  ${}^3\text{He}$ :



From here there are three possible paths to generate helium isotope  ${}^4\text{He}$ . In pp1 helium-4 comes from fusing two of the helium-3 nuclei produced; the pp2 and pp3 branches fuse  ${}^3\text{He}$  with a pre-existing  ${}^4\text{He}$  to make Beryllium-7. In the Sun, branch pp1 takes place with a frequency of 86%, pp2 with 14% and pp3 with 0.11%. There is also an extremely rare pp4 branch.

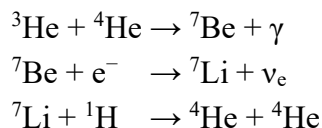
*The pp I branch*





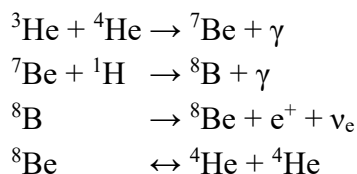
The complete pp I chain reaction releases a net energy of 26.7 MeV. The pp I branch is dominant at temperatures of 10 to 14 megakelvins (MK). Below 10 MK, the PP chain does not produce much  $^4\text{He}$ .

*The pp II branch*



The pp II branch is dominant at temperatures of 14 to 23 MK. 90% of the neutrinos produced in the reaction  ${}^7\text{Be}(e^-, \nu_e){}^7\text{Li}^*$  carry an energy of 0.861 MeV, while the remaining 10% carry 0.383 MeV (depending on whether lithium-7 is in the ground state or an excited state, respectively).

*The pp III branch*

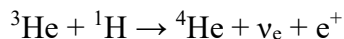


The pp III chain is dominant if the temperature exceeds 23 MK.

The pp III chain is not a major source of energy in the Sun (only 0.11%), but was very important in the solar neutrino problem because it generates very high energy neutrinos (up to 14.06 MeV).

*The pp IV or Hep*

This reaction is predicted but has never been observed due to its great rarity (about 0.3 parts per million in the Sun). In this reaction, Helium-3 reacts directly with a proton to give helium-4, with an even higher possible neutrino energy (up to 18.8 MeV).



***Energy release.***

Comparing the mass of the final helium-4 atom with the masses of the four protons reveals that 0.007 or 0.7% of the mass of the original protons has been lost. This mass has been converted into energy, in the form of gamma rays and neutrinos released during each of the individual reactions.

The total energy we get in one whole chain is



Only energy released as gamma rays will interact with electrons and protons and heat the interior of the Sun. This heating supports the Sun and prevents it from collapsing under its own weight. Neutrinos do not interact significantly with matter and do not help support the Sun against gravitational collapse. The neutrinos in the ppI, ppII and ppIII chains carry away the 2.0%, 4.0% and 28.3% of the energy respectively.

This creates a situation in which stellar nucleosynthesis produces large amounts of carbon and oxygen but only a small fraction of these elements is converted into neon and heavier elements. Both oxygen and carbon make up the *ash* of helium burning. Those nuclear resonances sensitively are arranged to create large amounts of carbon and oxygen, has been controversially cited as evidence of

the anthropic principle.

About 34% of this energy is carried away by neutrinos. That reaction is part of solar reaction, but if initial temperature is high, the reaction becomes an explosion.

The detonation wave works a short time. That supports the reactions (12) – (13). They produce energy up to 1.44 MeV. The reactions (12) – (14) produce energy up to 5.8 MeV. But after detonation wave and the full range of reactions the temperature of plasma is more than the temperature needed to pass the Coulomb barrier and the energy of explosion increases by 20 times.

## 5. Detonation theory

The one dimensional detonation wave may be computed by equations (see Fig.2):

1) Law of mass

$$\frac{D}{V_1} = \frac{v}{V_3}, \quad (15)$$

where  $D$  – speed of detonation, m/s;  $v$  – speed of ion sound, m/s about the front of detonation wave (eq.(11));  $V_1, V_3$  specific density of plasma in points 1, 3 respectively, kg/m<sup>3</sup>.

2) Law of momentum

$$p_1 + \frac{D^2}{V_1} = p_3 + \frac{v^2}{V_3}, \quad (16)$$

where  $p_1, p_3$  are pressures, N/m<sup>2</sup>, in point 1, 3 respectively.

3) Law of energy

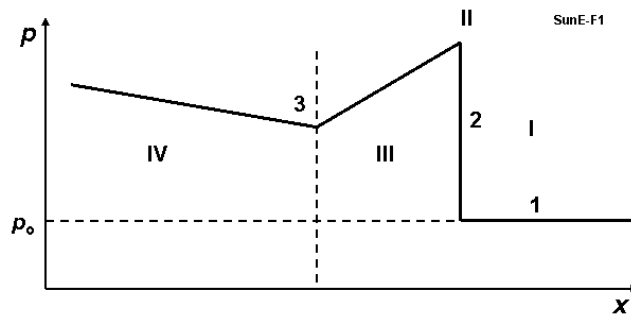
$$E_3 - E_1 = Q + 0.5(p_3 + p_1)(V_1 - V_3), \quad (17)$$

where  $E_3, E_1$  – internal energy, J/kg, of mass unit in point 3, 1 respectively,  $Q$  is nuclear energy, J/kg.

4) Speed of detonation is

$$D = \sqrt{2Q(\gamma^2 - 1)}, \quad (18)$$

$\gamma \approx 1.2 \div 1.4$  is adiabatic coefficient.



**Fig. 3.** Pressure in detonation wave. I – plasma, II – front of detonation wave, III – zone of the initial thermonuclear fusion reaction, IV – products of reaction and next reaction,  $p_0$  – initial pressure,  $x$  – distance.

## 6. Model of artificial Sun explosion and estimation of ignition

Thermonuclear reactions proceeding in the Sun's core are under high temperature and pressure. However the core temperature is substantially lower than that needed to overcome the Coulomb barrier. That way the thermonuclear reaction is very slow and the Sun's life cycle is about 10 billion years. But

that is enough output to keep the Sun a plasma ball, hot enough for life on Earth to exist. Now we are located in the middle of the Sun's life and have about 5 billions years until the Sun becomes a Red Giant.

However, this presumes that the Sun is stable against deliberate tampering. Supposing our postulations are correct, the danger exists that introducing a strong thermonuclear explosion into the Sun which is a container of fuel for thermonuclear reactions, the situation can be cardinally changed. For correct computations it is necessary to have a comprehensive set of full initial data (for example, all cross-section areas of all nuclear reactions) and supercomputer time. The author does not have access to such resources. That way he can only estimate probability of these reactions, their increasing or decreasing. Supportive investigations are welcome in order to restore confidence in humanity's long term future.

## 7. AB-Criterion for Solar Detonation

A self-supporting detonation wave is possible if the speed of detonation wave is greater or equals the ion sound speed:

$$D \geq v, \quad \text{where} \quad D = \sqrt{2Q(\gamma^2 - 1)}, \quad v = \left( \frac{\gamma z k T_k}{m_i} \right)^{1/2}. \quad (19)$$

Here  $Q$  is a nuclear specific heat [J/kg],  $\gamma = 1.2 \div 1.4$  is adiabatic coefficient (they are noted in (17)-(18));  $z$  is number of the charge of particle after fusion reaction ( $z=1$  for  ${}^2\text{H}$ ),  $k = 1.36 \times 10^{-23}$  is Boltzmann constant, J/K;  $T_k$  is temperature of plasma after fusion reaction in Kelvin degrees;  $m_i = \mu m_p$  is mass of ion after fusion reaction, kg;  $m_p = 1.67 \times 10^{-27}$  kg is mass of proton;  $\mu$  is relative mass,  $\mu=2$  for  ${}^2\text{H}$ .

When we have sign ">" the power of the detonation wave increases, when we have the sign "<" it decreases.

Substitute two last equations in the first equation in (19) we get

$$D^2 \geq v^2, \quad 2Q(\gamma^2 - 1) \geq \frac{\gamma z k T_k}{m_i}. \quad \text{where} \quad Q = \frac{f e E \tau}{n m_p} = \frac{1}{4} n^2 e E < \sigma v > \frac{\tau}{n m_p}, \quad (20)$$

where  $f$  is speed of nuclear reaction, s/m<sup>3</sup>;  $e = 1.6 \times 10^{-19}$  is coefficient for converting the energy from electron-volts to joules;  $E$  is energy of reaction in eV;  $n$  is number particles ( $p$  - protons) in m<sup>3</sup>;  $< \sigma v >$  is reaction rate, m<sup>3</sup>/s (fig.1),  $m_i = 2 m_p$ ,  $\tau$  is time, sec.

From (20) we get the AB-Criterion for artificial Sun explosion:

$$n \tau \geq \frac{\gamma z k T_k}{(\gamma^2 - 1) e E < \sigma v >} = \frac{1.16 \cdot 10^4 \gamma z k T_e}{(\gamma^2 - 1) e E < \sigma v >} = \frac{\gamma z T_e}{(\gamma^2 - 1) E < \sigma v >}, \quad (21)$$

where  $T_e$  is temperature of plasma after reaction in eV.

The offered AB-Criterion (21) is different from the well-known Lawson criterion

$$n_e \tau_e > \frac{12 k_B T_k}{E_{ch} < \sigma v >},$$

where  $E_{ch}$  is energy of reaction in keV,  $k_B$  is Boltzmann constant.

The offered AB-Criterion contains the  $\gamma$  adiabatic coefficient and  $z$  – number of electric charge in the electron charges. It is not surprising because Lawson derived his criterion from the condition where the energy of the reaction must be greater than the loss of energy by plasma into the reactor walls, where

$$W_{reaction} > W_{loss}.$$

In our case no the reactor walls and plasma reflects the any radiation.

The offered AB-Criterion is received from the condition (19): Speed of self-supporting detonation wave must be greater than the speed of sound where

$$D > v.$$

For main reaction  $p + p$  the AB-Criterion (21) has a form

$$n\tau \geq \frac{T_e}{E \langle \sigma v \rangle}. \quad (21a)$$

**Estimation.** Let us take the first step of the reaction  $^1\text{H} + ^1\text{H}$  (12)-(13) having in point 3 (fig.2)  $T_e = 10^5$  eV,  $E \approx 1.44 \times 10^6$  eV,  $\langle \sigma v \rangle \approx \times 10^{-22}$ . Substituting them in equation (21) we receive

$$n\tau > 0.7 \times 10^{21}. \quad (22)$$

The Sun surface (photosphere) has density  $n = 10^{23}$  1/m<sup>3</sup>, the encounter time of protons in the hypothetical detonation wave III (fig.2) may be over 0.01 sec. The values in left and right sides of (22) have the same order. That means a thermonuclear bomb exploded within the Sun may conceivably be able to serve as a detonator which produces a self-supported nuclear reaction and initiates the artificial explosion of the Sun.

After the initial reaction the temperature of plasma is very high (>1 MeV) and time of next reaction may be very large (hundreds of seconds), the additional energy might in these conditions increase up to 26 MeV.

A more accurate computation is possible but will require cooperation of an interested supercomputer team with the author, or independent investigations with similar interests.

## 8. Penetration of Thermonuclear Bomb Into Sun

The Sun is a ball of plasma (ionized gases), not a solid body. A properly shielded thermonuclear bomb can permeate deep into the Sun. The warhead may be protected on its' way down by a special high reflectivity mirror offered, among others, by author A.A. Bolonkin in 1983 [12] and described in [7] Chapters 12, 3A, [8] Ch.5, [9]-[12]. This mirror allows to maintain a low temperature of the warhead up to the very boundary of the solar photosphere. At that point its' velocity is gigantic, about 617.6 km/s, assuring a rapid penetration for as far as it goes.

The top solar atmosphere is very rarefied; a milliard (US billion) times less than the Earth's atmosphere. The Sun's photosphere has a density approximately 200 times less than the Earth's atmosphere. Some references give a value of only 0.0000002 gm/cm<sup>3</sup> (.1 millibar) at the photosphere surface. Since present day ICBM warheads can penetrate down (by definition) to the 1 bar level (Earth's surface) and that is by no means the boundary of the feasible, the 10 bar level may be speculated to be near-term achievable. The most difficult entry yet was that of the Galileo atmospheric probe on Dec. 7, 1995 [17]. The Galileo Probe was a 45° sphere-cone that entered Jupiter's atmosphere at 47.4 km/s (atmosphere relative speed at 450 km above the 1 bar reference altitude). The peak deceleration experienced was 230 g (2.3 km/s<sup>2</sup>). Peak stagnation point pressure before aeroshell jettison was 9 bars (900 kPa). The peak shock layer temperature was approximately 16000 K (and remember this is into hydrogen (mostly) the solar photosphere is merely 5800 K). Approximately 26% of the Galileo Probe's original entry mass of 338.93 kg was vaporized during the 70 second heat pulse. Total blocked heat flux peaked at approximately 15000 W/cm<sup>2</sup> (hotter than the surface of the Sun).

If the entry vehicle was not optimized for slowdown as the Galileo Probe but for penetration like a modern ICBM warhead, with extra ablatives and a sharper cone half-angle, achievable penetration would be deeper and faster. If 70 seconds atmospheric penetration time could be achieved, (with minimal slowdown) perhaps up to 6 % of the way to the center might be achieved by near term technology.

The outer penetration shield of the warhead may be made from carbon (which is an excellent ablative heat protector). The carbon is also an excellent nuclear catalyst of the nuclear reactions in the CNO solar thermonuclear cycle and may significantly increase the power of the initial explosion.

A century hence, what level of penetration of the solar interior is possible? This depth is unknown to the author, exceeding plausible engineering in the near term. Let us consider a hypothetical point (top of the radiation layer) 30 percent of the way from the surface to the core, at the density of  $0.2 \text{ g/cm}^3$  with a temperature of  $2,000,000^\circ \text{C}$ . No material substance can withstand such heat—for extended periods.

We may imagine however hypothetical penetration aids, analogous to ICBM techniques of a half century ago. Shock waves bearing the brunt of the encountered heat and forcing it aside, the opacity shielding the penetrator. A form of multiple disposable shock cones may be employed to give the last in line a chance to survive; indeed the destruction of the next to last may arm the trigger.

If the heat isolation shield and multiple penetration aids can protect the bomb at near entry velocity for a hellish *10 minute interval*, (which to many may seem impossible but which cannot be excluded without definitive study—remember we are speaking now of centuries hence, not the near term case above—see reference 14) that means the bomb may reach the depth of 350 thousands kilometers or  $0.5R$ , where  $R = 696 \times 10^3 \text{ km}$  is Sun's radius.

The Sun density via relative Sun depth may be estimated by the equation

$$n = n_s e^{20.4\bar{h}}, \quad \text{where } \bar{h} = h/R, \quad (23)$$

where  $n_s \approx 10^{23} \text{ 1/m}^3$  is the plasma density on the photosphere surface;  $h$  is deep, km;  $R = 696 \times 10^3$  is solar radius, km. At a solar interior depth of  $h = 0.5R$  the relative density is greater by *27 thousand times* than on the Sun's surface.

Here the density and temperature are significantly more than on the photosphere's surface. And conditions for the detonation wave and thermonuclear reaction are 'better'—from the point of view of the attacker.

## 9. Estimation of nuclear bomb needed for Sun explosion

Sound speed into plasma headed up  $T = 100 \text{ K}$  million degrees is about

$$v \approx 10^2 T^{0.5} \text{ m/s} = 10^6 \text{ m/s}. \quad (24)$$

Time of nuclear explosion (a full nuclear reaction of bomb) is less  $t = 10^{-4} \text{ sec}$ . Therefore the radius of heated Sun photosphere is about  $R = vt = 100 \text{ m}$ , volume  $V$  is about

$$V = \frac{4}{3} \pi R^3 \approx 4 \cdot 10^6 \text{ m}^3. \quad (25)$$

Density of Sun photosphere is  $p = 2 \times 10^{-4} \text{ kg/m}^3$ . Consequently the mass of the heated photosphere is about  $m = pV = 1000 \text{ kg}$ .

The requested power of the nuclear bomb for heating this mass for temperature  $T = 10^4 \text{ eV}$  (100 K million degrees) is approximately

$$E = 10^3 \times 10^4 / 1.67 \times 10^{-27} \text{ eV} \approx 0.6 \cdot 10^{34} \text{ eV} \approx 2 \cdot 10^{15} \text{ J} \approx 0.5 \text{ Mt}. \quad (26)$$

The requested power of nuclear bomb is about 0.5 Megatons. The average power of the current thermonuclear bomb is 5 – 10 Mt. That means the current thermonuclear bomb may be used as a fuse of Sun explosion. That estimation needs in a more complex computation by a power computer.

## 10. Results of research

The Sun contains 73.46 % hydrogen by weight. The isotope hydrogen-1 (99.985% of hydrogen in nature) is usable fuel for a fusion thermonuclear reaction.

The p-p reaction runs slowly within the Sun because its temperature is low (relative to the temperatures of nuclear reactions). If we create higher temperature and density in a limited region of the solar interior, we may be able to produce self-supporting, more rapid detonation thermonuclear reactions that may spread to the full solar volume. This is analogous to the triggering mechanisms in a thermonuclear bomb. Conditions within the bomb can be optimized in a small area to initiate ignition, build a spreading reaction and then feed it into a larger area, allowing producing a ‘solar hydrogen bomb’ of any power—but not necessarily one whose power can be limited. In the case of the Sun certain targeting practices may greatly increase the chances of an artificial explosion of the entire Sun. This explosion would annihilate the Earth and the Solar System, as we know them today.

Author A.A. Bolonkin has researched this problem and shown that an artificial explosion of Sun cannot be precluded. In the Sun’s case this lacks only an initial fuse, which induces the self-supporting detonation wave. This research has shown that a thermonuclear bomb exploded within the solar photosphere surface may be the fuse for an accelerated series of hydrogen fusion reactions.

The temperature and pressure in this solar plasma may achieve a temperature that rises to billions of degrees in which all thermonuclear reactions are accelerated by many thousands of times. This power output would further heat the solar plasma. Further increasing of the plasma temperature would, in the worst case, climax in a solar explosion.

The possibility of initial ignition of the Sun significantly increases if the thermonuclear bomb is exploded under the solar photosphere surface. The incoming bomb has a diving speed near the Sun of about 617 km/sec. Warhead protection to various depths may be feasible –ablative cooling which evaporates and protects the warhead some minutes from the solar temperatures. The deeper the penetration before detonation the temperature and density achieved greatly increase the probability of beginning thermonuclear reactions which can achieve explosive breakout from the current stable solar condition.

Compared to actually penetrating the solar interior, the flight of the bomb to the Sun, (with current technology requiring a gravity assist flyby of Jupiter to cancel the solar orbit velocity) will be easy to shield from both radiation and heating and melting. Numerous authors, including A.A. Bolonkin in works [7]-[12] offered and showed the high reflectivity mirrors which can protect the flight article within the orbit of Mercury down to the solar surface.

The author A.A. Bolonkin originated the AB Criterion, which allows estimating the condition required for the artificial explosion of the Sun.

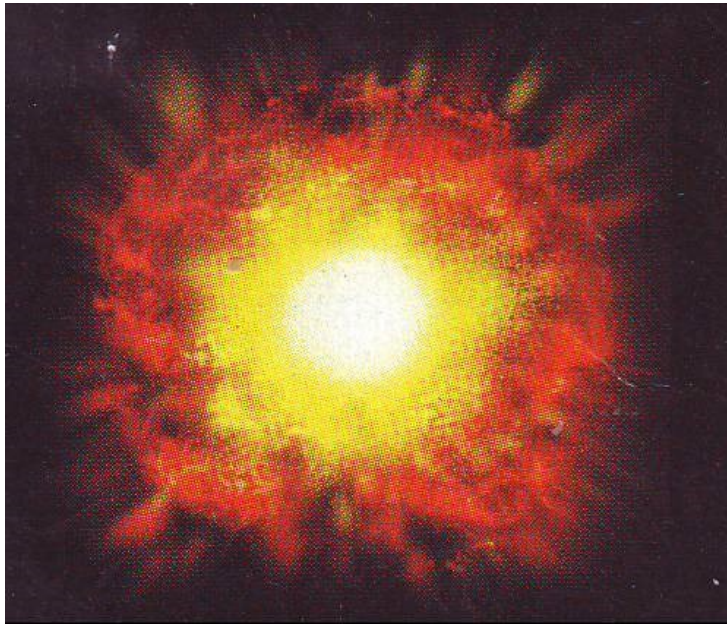
## 11. Discussion

If we (humanity—unfortunately in this context, an insane dictator representing humanity for us) create a zone of limited size with a high temperature capable of overcoming the Coulomb barrier (for example by insertion of a specialized thermonuclear warhead) into the solar photosphere (or lower), can this zone ignite the Sun’s photosphere (ignite the Sun’s full load of thermonuclear fuel)? Can this zone self-support progressive runaway reaction propagation for a significant proportion of the available thermonuclear fuel?

If it is possible, researchers can investigate the problems: What will be the new solar temperature? Will this be metastable, decay or runaway? How long will the transformed Sun live, if only a minor change? What the conditions will be on the Earth during the interval, if only temporary? If not an explosion but an enhanced burn results the Sun might radically increase in luminosity for –say--a few hundred years. This would suffice for an average Earth temperature of hundreds of degrees over 0 °C. The oceans would evaporate and Earth would bake in a Venus like greenhouse, or even lose its’ atmosphere entirely.

It would not take a full scale solar explosion, to annihilate the Earth as a planet for Man. (For a classic report on what makes a planet habitable, co-authored by Issac Asimov, see [http://www.rand.org/pubs/commercial\\_books/2007/RAND\\_CB179-1.pdf](http://www.rand.org/pubs/commercial_books/2007/RAND_CB179-1.pdf) .

Converting the sun even temporarily into a ‘superflare’ star, (which may hugely vary its output by many percent, even many times) over very short intervals, not merely in heat but in powerful bursts of shorter wavelengths) could kill by many ways, notably ozone depletion—thermal stress and atmospheric changes and hundreds of others of possible scenarios—in many of them, human civilization would be annihilated. And in many more, humanity as a species would come to an end.



**Fig. 4.** Sun explosion



**Fig. 5.** Sun explosion. Result on the Earth.



The reader naturally asks: Why even contemplate such a horrible scenario? It is necessary because as thermonuclear and space technology spreads to even the least powerful nations in the centuries ahead, a dying dictator having thermonuclear missile weapons can produce (with some considerable mobilization of his military/industrial complex)—the artificial explosion of the Sun and take into his grave the whole of humanity. It might take tens of thousands of people to make and launch the hardware, but only a very few need know the final targeting data of what might be otherwise a weapon purely thought of (within the dictator's defense industry) as being built for peaceful, deterrent use.

Those concerned about Man's future must know about this possibility and create some protective system—or ascertain on theoretical grounds that it is entirely impossible, which would be comforting.

Suppose, however that some variation of the following is possible, as determined by other researchers with access to good supercomputer simulation teams. What, then is to be done?

The action proposed depends on what is shown to be possible.

Suppose that no such reaction is possible—it dampens out unnoticeably in the solar background, just as no fission bomb triggered fusion of the deuterium in the oceans proved to be possible in the Bikini test of 1946. This would be the happiest outcome.

Suppose that an irruption of the Sun's upper layers enough to cause something operationally similar to a targeted 'coronal mass ejection' – CME-- of huge size targeted at Earth or another planet? Such a CME like weapon could have the effect of a huge electromagnetic pulse. Those interested should look up data on the 1859 solar superstorm, the Carrington event, and the Stewart Super Flare. Such a CME/EMP weapon might target one hemisphere while leaving the other intact as the world turns. Such a disaster could be surpassed by another step up the escalation ladder-- by a huge hemisphere killing thermal event of ~12 hours duration such as postulated by science fiction writer Larry Niven in his 1971 story "Inconstant Moon"—apparently based on the Thomas Gold theory (ca. 1969-70) of rare solar superflares of 100 times normal luminosity. Subsequent research<sup>18</sup> (Wdowczyk and Wolfendale, 1977) postulated horrific levels of solar activity, ozone depletion and other such consequences might cause mass extinctions. Such an improbable event might not occur naturally, but could it be triggered by an interested party? A triplet of satellites monitoring at all times both the sun from Earth orbit and the 'far side' of the Sun from Earth would be a good investment both scientifically and for purposes of making sure no 'creative' souls were conducting trial CME eruption tests!

Might there be peaceful uses for such a capability? In the extremely hypothetical case that a yet greater super-scale CME could be triggered towards a given target in space, such a pulse of denser than naturally possible gas might be captured by a giant braking array designed for such a purpose to provide huge stocks of hydrogen and helium at an asteroid or moon lacking these materials for purposes of future colonization.

A worse weapon on the scale we postulate might be an asymmetric eruption (a form of directed thermonuclear blast using solar hydrogen as thermonuclear fuel), which shoots out a coherent (in the sense of remaining together) burst of plasma at a given target without going runaway and consuming the outer layers of the Sun. If this quite unlikely capability were possible at all (dispersion issues argue against it—but before CMEs were discovered, they too would have seemed unlikely), such an apocalyptic 'demo' would certainly be sufficient emphasis on a threat, or a means of warfare against a colonized solar system. With a sufficient thermonuclear burn—and if the condition of nondispersion is fulfilled—might it be possible to literally strip a planet—Venus, say—of its' atmosphere? (It might require a mass of fusion fuel—and a hugely greater non-fused expelled mass comparable in total to the mass to be stripped away on the target planet.)

It is not beyond the limit of extreme speculation to imagine an expulsion of this order sufficient to strip Jupiter's gas layers off the 'Super-Earth' within. —To strip away 90% or more of Jupiter's mass

(which otherwise would take perhaps ~400 Earth years of total solar output to disassemble with perfect efficiency and neglecting waste heat issues). It would probably waste a couple Jupiter masses of material (dispersed hydrogen and helium). It would be an amazing engineering capability for long term space colonization, enabling substantial uses of materials otherwise unobtainable in nearly all scenarios of long term space civilization.

Moving up on the energy scale-- “boosting” or “damping” a star, pushing it into a new metastable state of greater or lesser energy output for times not short compared with the history of civilization, might be a very welcome capability to colonize another star system—and a terrifying reason to have to make the trip.

And of course, in the uncontrollable case of an induced star explosion, in a barren star system it could provide a nebula for massive mining of materials to some future super-civilization. It is worth noting in this connection that the Sun constitutes 99.86 percent of the material in the Solar System, and Jupiter another .1 percent. Literally a thousand Earth masses of solid (iron, carbon) building materials might be possible, as well as thousands of oceans of water to put inside space colonies in some as yet barren star system.

But here in the short-term future, in our home solar system, such a capability would present a terrible threat to the survival of humanity, which could make our own solar system completely barren.

The list of possible countermeasures does not inspire confidence. A way to interfere with the reaction (dampen it once it starts)? It depends on the spread time, but seems most improbable. We cannot even stop nuclear reactions once they take hold on Earth—the time scales are too short.

Is defense of the Sun possible? Unlikely—such a task makes missile defense of the Earth look easy. Once a gravity assist Jupiter flyby nearly stills the velocity with which a flight article orbits the Sun, it will hang relatively motionless in space and then begin the long fall to fiery doom. A rough estimate yields only one or two weeks to intercept it within the orbit of Mercury, and the farther it falls the faster it goes, to science fiction-like velocities sufficient to reach Pluto in under six weeks before it hits.

A perimeter defense around the Sun? The idea seems impractical with near term technology.

The Sun is a hundred times bigger sphere than Earth in every dimension. If we have 10,000 ready to go interceptor satellites with extreme sunshields that function a few solar radii out each one must be able to intercept with 99% probability the brightening light heading toward its’ sector of the Sun over a circle the size of Earth, an incoming warhead at around 600 km/sec.

If practical radar range from a small set is considered (4th power decline of echo and return) as 40,000 km then only 66 seconds would be available to plot a firing solution and arm for a destruct attempt. More time would be available by a telescope looking up for brightening, infalling objects—but there are many natural incoming objects such as meteors, comets, etc. A radar might be needed just to confirm the artificial nature of the in-falling object (given the short actuation time and the limitations of rapid storable rocket delta-v some form of directed nuclear charge might be the only feasible countermeasure) and any leader would be reluctant to authorize dozens of nuclear explosions per year automatically (there would be no time to consult with Earth, eight light-minutes away—and eight more back, plus decision time). But the cost of such a system, the reliability required to function endlessly in an area in which there can presumably be no human visits and the price of its’ failure, staggers the mind. And such a 'thin' system would be not difficult to defeat by a competent aggressor...

A satellite system near Earth for destroying the rockets moving to the Sun may be a better solution, but with more complications, especially since it would by definition also constitute an effective missile defense and space blockade. Its’ very presence may help spark a war. Or if only partially complete but under construction, it may invite preemption, perhaps on the insane scale that we here discuss...

Astronomers see the explosion of stars. They name these stars novae and supernovae—“New Stars” and try to explain (correctly, we are sure, in nearly all cases) their explosion by natural causes. But some few of them, from unlikely spectral classifications, may be result of war between civilizations or fanatic dictators inflicting their final indignity upon those living on planets of the given star. We have enough disturbed people, some in positions of influence in their respective nations and organizations and suicide oriented violent people on Earth. But a nuclear bomb can destroy only one city. A dictator having possibility to destroy the Solar System as well as Earth can blackmail all countries—even those of a future Kardashev scale 2 star-system wide civilization-- and dictate his will/demands on any civilized country and government. It would be the reign of the crazy over the sane.

Author A.A. Bolonkin already warned about this possibility in 2007 (see his interview [http://www.pravda.ru/science/planet/space/05-01-2007/208894-sun\\_detonation-0](http://www.pravda.ru/science/planet/space/05-01-2007/208894-sun_detonation-0) [15] (in Russian) (A translation of this is appended at the end of this article) and called upon scientists and governments to research and develop defenses against this possibility. But some people think the artificial explosion of Sun impossible. This led to this current research to give the conditions where such detonations are indeed possible. That shows that is conceivably possible even at the present time using current rockets and nuclear bombs—and only more so as the centuries pass. Let us take heed, and know the risks we face—or disprove them.

The first information about this work was published in [15]. This work produced the active Internet discussion in [19]. Among the raised questions were the following:

1) It is very difficult to deliver a warhead to the Sun. The Earth moves relative to the Sun with a orbital velocity of 30 km/s, and this speed should be cancelled to fall to the Sun. Current rockets do not suffice, and it is necessary to use gravitational maneuvers around planets. For this reason (high delta-V (velocity changes required) for close solar encounters, the planet Mercury is so badly investigated (probes there are expensive to send).

*Answer:* The Earth has a speed of 29 km/s around the Sun and an escape velocity of only 11 km/s. But Jupiter has an orbital velocity of only 13 km/sec and an escape velocity of 59.2 km/s. Thus, the gravity assist Jupiter can provide is more than the Earth can provide, and the required delta-v at that distance from the Sun far less—enough to entirely cancel the sun-orbiting velocity around the Sun, and let it begin the long plunge to the Solar orb at terminal velocity achieving Sun escape speed 617.6 km/s. Notice that for many space exploration maneuvers, we require a flyby of Jupiter, exactly to achieve such a gravity assist, so simply guarding against direct launches to the Sun from Earth would be futile!

2) Solar radiation will destroy any a probe on approach to the Sun or in the upper layers of its photosphere.

*Answer:* It is easily shown, the high efficiency AB-reflector can full protection the apparatus. See [7] Chapters 12, 3A, [8] Ch.5, [9]-[12].

3) The hydrogen density in the upper layers of the photosphere of the Sun is insignificant, and it would be much easier to ignite hydrogen at Earth oceans if it in general is possible.

*Answer:* The hydrogen density is enough known. The Sun has gigantic advantage – that is PLASMA. Plasma of sufficient density reflects or blocks radiation—it has opacity. That means: **no radiation losses in detonation**. It is very important for heating. The AB Criterion in this paper is received for PLASMA. Other planets of Solar system have MOLECULAR atmospheres which passes radiation. No sufficient heating – no detonation! The water has higher density, but water passes the high radiation (for example  $\gamma$ -radiation) and contains a lot of oxygen (89%), which may be bad for the thermonuclear reaction. This problem needs more research.

## 12. Summary

This is only an initial investigation. Detailed supercomputer modeling which allows more accuracy would greatly aid prediction of the end results of a thermonuclear explosion on the solar photosphere.

Author invites the attention of scientific society to detailed research of this problem and devising of protection systems if it proves a feasible danger that must be taken seriously. The other related ideas author Bolonkin offers in [5]-[15].

### References

- (The reader find some author's works in <http://Bolonkin.narod.ru/p65.htm>, <http://www.scribd.com> search "Bolonkin"; <http://Arxiv.org> Search: "Bolonkin", in <http://aiaa.org> search "Bolonkin" and books: Bolonkin A.A., "Non-Rocket Space Launch and flight", Elsevier, 2006, 488 pgs.; Bolonkin A.A., "New Concepts, ideas, and Innovations in Technology and Human life", NOVA, 2008, 502 pg.; Bolonkin A.A., Cathcart R.B., "Macro-Projects: Environment and Technology", NOVA, 2009, 536 pgs).
1. AIP Physics desk reference, 3rd Ed., Spring, 888 pgs.
  2. Handbook of Physical Quantities, Ed. Igor Grigoriev, CRC Press, 1997, USA.
  3. I.K. Kikoin (Ed.), Tables of physical values, Atomizdat, Moscow, 1975, 1006 pgs, (in Russian).
  4. Nishikawa K., Wakatani M., Plasma Physics, Spring, 2000.
  5. Bolonkin A.A., New AB-Thermonuclear Reactor for Aerospace, Presented as AIAA-2006-7225 to Space-2006 Conference, 19-21 September, 2006, San Jose, CA, USA (see also <http://arxiv.org> search "Bolonkin"). <http://arxiv.org/ftp/arxiv/papers/0706/0706.2182.pdf> , <http://arxiv.org/ftp/arxiv/papers/0803/0803.3776.pdf> .
  6. Bolonkin A.A., Simplest AB-Thermonuclear Space Propulsion and Electric Generator, <http://arxiv.org> search "Bolonkin". <http://arxiv.org/ftp/physics/papers/0701/0701226.pdf> .
  7. Bolonkin A.A., "Non-Rocket Space Launch and Flight", Elsevier, 2006, 488 pgs. <http://Bolonkin.narod.ru/p65.htm> , or <http://www.scribd.com/doc/24056182> . The book contains theories of the more then 20 new revolutionary author ideas in space and technology.
  8. Bolonkin A.A., *New concepts, ideas and innovations in aerospace and technology*, Nova, 2007. The book contains theories of the more then 20 new revolutionary author ideas in space and technology. <http://Bolonkin.narod.ru/p65.htm> , or <http://www.scribd.com/doc/24057071> .
  9. Bolonkin A.A., Cathcart R.B., "Macro-Projects: Environment and Technology", NOVA, 2009, 536 pgs. <http://Bolonkin.narod.ru/p65.htm> . <http://www.scribd.com/doc/24057930> . Book contains many new revolutionary ideas and projects.
  10. Bolonkin A.A., High Speed AB Solar Sail. This work is presented as paper AIAA-2006-4806 for 42 Joint Propulsion Conference, Sacramento, USA, 9-12 July, 2006, USA (see also <http://arxiv.org> search "Bolonkin"). <http://arxiv.org/ftp/physics/papers/0701/0701073.pdf> .
  11. Bolonkin A.A., Light Multi-reflex Engine, Journal of British Interplanetary Society, Vol 57, No.9/10, 2004, pp. 353-359.
  12. Bolonkin, A.A., Light Pressure Engine, Patent (Author Certificate) # 1183421, 1985, USSR (priority on 5 January 1983).
  13. Bolonkin A.A., Converting of Matter to Nuclear Energy by AB-Generator. *American Journal of Engineering and Applied Sciences*. 2 (2), 2009, p.683-693. [on line] <http://www.scipub.org/fulltext/ajeas/ajeas24683-693.pdf> or <http://www.scribd.com/doc/24048466/>
  14. Bolonkin A.A., Femtotechnology. Nuclear AB-Matter with Fantastic Properties, *American Journal of Engineering and Applied Sciences*. 2 (2), 2009, p.501-514. [On line]: <http://www.scipub.org/fulltext/ajeas/ajeas22501-514.pdf> or <http://www.scribd.com/doc/24046679/>
  15. Bolonkin A.A., Artificial Explosion of Sun. Interview for newspaper [www.PravdaRu.ru](http://www.PravdaRu.ru) of 5 January 2007. [http://www.pravda.ru/science/planet/space/05-01-2007/208894-sun\\_detonation-0](http://www.pravda.ru/science/planet/space/05-01-2007/208894-sun_detonation-0) (in Russian).

16. Wikipedia. Some background material in this article is gathered from Wikipedia under the Creative Commons license. <http://wikipedia.org> .
17. Solar Physics Group at NASA's Marshall Space Flight Center website for solar facts <http://solarscience.msfc.nasa.gov/>
18. Wdowczyk J and Wolfendale A W, Cosmic rays and ancient catastrophes, Nature, 268 (1977) 510. Abstract available at: <http://www.nature.com/nature/journal/v268/n5620/abs/268510a0.html>
19. Turchin A.V., The possibility of artificial fusion explosion of giant planets and other objects of Solar system, 2009. <http://www.scribd.com/doc/8299748/Giant-planets-ignition>

Possible form of the sun explosion apparatus (credit NASA)



## Chapter 13

# Review of New Concepts, Ideas and Innovations in Space Towers\*

### Abstract

Under Space Tower the author understands structures having height from 100 km to the geosynchronous orbit and supported by Earth's surface. The classical Space Elevator is not included in space towers. That has three main identifiers which distinguish from Space Tower: Space Elevator has part over Geosynchronous Orbit (GSO) and all installation supported only the Earth's centrifugal force, immobile cable connected to Earth's surface, no pressure on Earth's surface.

A lot of new concepts, ideas and innovation in space towers were offered, developed and researched in last years especially after 2000. For example: optimal solid space towers, inflatable space towers (include optimal space tower), circle and centrifugal space towers, kinetic space towers, electrostatic space towers, electromagnetic space towers, and so on.

Given review shortly summarizes these researches and gives a brief description of them, notes some of their main advantages, shortcomings, defects and limitations.

-----  
**Key words:** Space tower, optimal space mast, inflatable space tower, kinetic space tower, electrostatic space tower, magnetic space tower.

\* This Chapter is written together with Mark Krinker.

### Introduction

**Brief History** [6]. The idea of building a tower high above the Earth into the heavens is very old [1],[6]. The Great Pyramid of Giza in Egypt constructed c.2570 BCE has a height 146 m. The writings of Moses, about 1450 BC, in Genesis, Chapter 11, refer to an early civilization that in about 2100 BC tried to build a tower to heaven out of brick and tar. This construction was called the Tower of Babel, and was reported to be located in Babylon in ancient Mesopotamia. Later in chapter 28, about 1900 BC, Jacob had a dream about a staircase or ladder built to heaven. This construction was called Jacob's Ladder. More contemporary writings on the subject date back to K.E. Tsiolkovski in his manuscript "Speculation about Earth and Sky and on Vesta," published in 1895 [2-3]. Idea of Space Elevator was suggested and developed Russian scientist Yuri Artsutanov and was published in the Sunday supplement of newspaper "Komsomolskaya Pravda" in 1960 [4]. This idea inspired Sir Arthur Clarke to write his novel, The Fountains of Paradise, about a Space Elevator located on a fictionalized Sri Lanka, which brought the concept to the attention of the entire world [5].

**Tallest structures.** This category does not require the structure be "officially" opened. The tallest man-made structure is Burj Khalifa, a skyscraper in Dubai that reached 828 m (2,717 ft) in height on 17 January 2009. By 7 April 2008 it had been built higher than the KVLV-TV mast in North Dakota, USA. That September it officially surpassed Poland's 646.38 m (2,120.7 ft) Warsaw radio mast, which stood from 1974 to 1991, to become the tallest structure ever built. Guyed lattice towers such as these masts had held the world height record since 1954.

The CN Tower in Toronto, Canada, standing at 553.3 m (1,815 ft), was formerly the world's tallest completed freestanding structure on land. Opened in 1976, it was surpassed in height by the rising Burj

Khalifa on 12 September 2007. It has the world's second highest public observation deck at 446.5 m (1,465 ft).

Taipei 101 in Taipei, Taiwan, was the world's tallest inhabited building in only one of the four main categories that are commonly measured: at 509.2 m (1,671 ft) as measured to its architectural height (spire). The height of its roof, 449.2 m (1,474 ft), and highest occupied floor, 439.2 m (1,441 ft), had been overtaken by the Shanghai World Financial Center with corresponding heights of 487 m (1,598 ft) and 474 m (1,555 ft) respectively. Willis Tower (formerly Sears Tower) was highest in the final category: the greatest height to top of antenna of any building in the world at 527.3 m (1,730 ft).

Burj Khalifa broke the height record in all four categories for completed buildings by a wide margin. The Shanghai World Financial Center had the world's highest roof, highest occupied floor, and the world's highest public observation deck at 474.2 m (1,556 ft). It retains the latter record, as Burj Khalifa's official observation deck will be at 442 m (1,450 ft).

Current materials make it possible even today to construct towers many kilometers in height. However, conventional towers are very expensive, costing tens of billions of dollars. When considering how high a tower can be built, it is important to remember that it can be built to many kilometers of height if the base is large enough.

**The tower applications.** The high towers (3–100 km) have numerous applications for government and commercial purposes:

- Entertainment and observation desk for tourists. Tourists could see over a huge area, including the darkness of space and the curvature of the Earth's horizon.
- Communication boost: A tower tens of kilometers in height near metropolitan areas could provide much higher signal strength than orbital satellites.
- Low Earth orbit (LEO) communication satellite replacement: Approximately six to ten 100-km-tall towers could provide the coverage of a LEO satellite constellation with higher power, permanence, and easy upgrade capabilities.
- Drop tower: tourists could experience several minutes of free-fall time. The drop tower could provide a facility for experiments.
- A permanent observatory on a tall tower would be competitive with airborne and orbital platforms for Earth and space observations.
- Solar power receivers: Receivers located on tall towers for future space solar power systems would permit use of higher frequency, wireless, power transmission systems (e.g. lasers).

## Main types of space towers

### 1. Solid towers [6]-[8].

The review of conventional solid high altitude and space towers is in [1]. The first solid space tower was offered in [2-3]. The optimal solid towers are detail researched in series works presented in [6-8]. Works contain computation the optimal (minimum weight) sold space towers up 40,000 km. Particularly, authors considered solid space tower having the rods filled by light gas as hydrogen or helium. It is shown the solid space tower from conventional material (steel, plastic) can be built up 100-200 km. The GEO tower requests the diamond.

The computation of the optimal solid space towers presented in [6-8] give the following results:

**Project 1. Steel tower 100 km height.** The optimal steel tower (mast) having the height 100 km, safety pressure stress  $K = 0.02$  (158 kg/mm<sup>2</sup>)( $K$  is ratio pressure stress to density of material divided by 10<sup>7</sup>) must have the bottom cross-section area approximately in 100 times more then top cross-



section area and weight is 135 times more than top load. For example, if full top load equals 100 tons (30 tons support extension cable + 70 tons useful load), the total weight of main columns 100 km tower-mast (without extension cable) will be 13,500 tons. It is less than a weight of current skyscrapers (compare with 3,000,000 tons of Toronto tower having the 553 m height). In reality if the safety stress coefficient  $K = 0.015$ , the relative cross-section area and weight will sometimes be more but it is a possibility of current building technology.

**Project 2. GEO 37,000 km Space Tower (Mast).** The research shows the building of the geosynchronous tower-mast (include the optimal tower-mast) is very difficult. For  $K = 0.3$  (it is over the top limit margin of safety for quartz, corundum) the tower mass is ten millions of times more than load, the extensions must be made from nanotubes and they weakly help. The problems of stability and flexibility then appear. The situation is strongly improved if tower-mast built from diamonds (relative tower mass decreases up 100). But it is not known when we will receive the cheap artificial diamond in unlimited amount and can create from it building units.

**Note: Using the compressive rods** [8]. The rod compressed by gas can keep more compressive force because internal gas makes a tensile stress in a rod material. That longitudinal stress cannot be more than a half safety tensile stress of rod material because the compressed gas creates also a tensile radial rod force (stress) which is two times more than longitudinal tensile stress. As the result the rod material has a complex stress (compression in a longitudinal direction and a tensile in the radial direction). Assume these stress is independent. The gas has a weight which must be added to total steel weight. Safety pressure for steel and duralumin from the internal gas increases  $K$  in 35 - 45%.

Unfortunately, the gas support depends on temperature. That means the mast can loss this support at night. Moreover, the construction will contain the thousands of rods and some of them may be not enough leakproof or lose the gas during of a design lifetime. I think it is a danger to use the gas pressure rods in space tower.

## 2. Inflatable tower [9]-[12].

The optimal (minimum weight of cover) inflatable towers were researched and computed in [9-12].

The proposed inflatable towers are cheaper by factors of hundreds. They can be built on the Earth's surface and their height can be increased as necessary. Their base is not large. The main innovations in this project are the application of helium, hydrogen, or warm air for filling inflatable structures at high altitude and the solution of a safety and stability problem for tall (thin) inflatable columns, and utilization of new artificial materials, as artificial fiber, whisker and nanotubes.

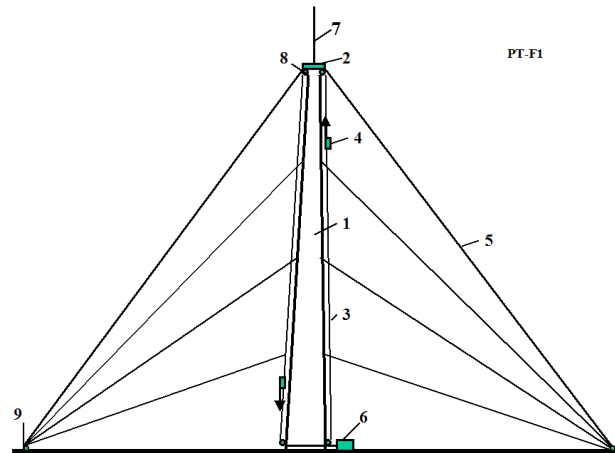
The results of computation for optimal inflatable space towers taken from [11] are below.

**Project 1. Inflatable 3 km tower-mast.** (Base radius 5 m, 15 ft,  $K = 0.1$ ). This inexpensive project provides experience in design and construction of a tall inflatable tower, and of its stability. The project also provides funds from tourism, radio and television. The inflatable tower has a height of 3 km (10,000 ft). Tourists will not need a special suit or breathing device at this altitude. They can enjoy an Earth panorama of a radius of up 200 km. The bravest of them could experience 20 seconds of free-fall time followed by 2g overload.

*Results of computations.* Assume the additional air pressure is 0.1 atm, air temperature is 288 °K (15 °C, 60 °F), base radius of tower is 5 m,  $K = 0.1$ . If the tower cone is optimal, the tower top radius must be 4.55 m. The maximum useful tower top lift is 46 tons. The cover thickness is 0.087 mm at the base and 0.057 mm at the top. The outer cover mass is only 11.5 tons.

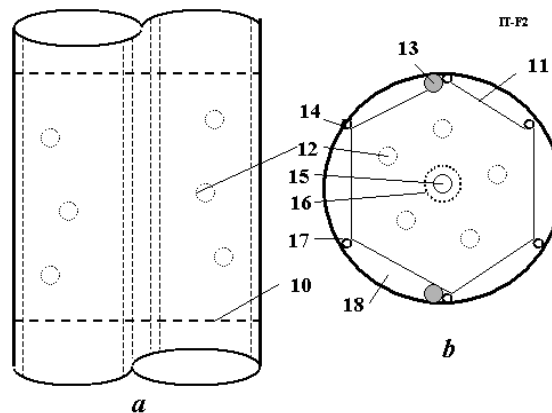
If we add light internal partitions, the total cover weight will be about 16 – 18 tons (compared to 3 million tons for the 553 m tower in Toronto). Maximum safe bending moment versus altitude ranges

from 390 ton×meter (at the base) to 210 ton×meter at the tower top.



**Fig. 1.** Inflatable tower.

*Notations:* 1 - Inflatable column, 2 - observation desk, 3 - load cable elevator, 4 - passenger cabin, 5 - expansion, 6 - engine, 7 - radio and TV antenna, 8 - rollers of cable transport system, 9 - control.



**Fig.2.** Section of inflatable tower. *Notations:* 10 – horizontal film partitions; 11 – light second film (internal cover); 12 – air balls-- special devices like floating balloons to track leaks (will migrate to leak site and will temporarily seal a hole); 13 – entrance line of compression air and pressure control; 14 – exit line of air and control; 15 – control laser beam; 16 – sensors of laser beam location; 17 – control cables and devices; 18 – section volume.

**Project 2. Helium tower 30 km** (Base radius is 5 m, 15 ft,  $K = 0.1$ )

*Results of computation.* Let us take the additional pressure over atmospheric pressure as 0.1 atm. For  $K = 0.1$  the radius is 2 m at an altitude of 30 km. For  $K = 0.1$  useful lift force is about 75 tons at an altitude of 30 km, thus it is a factor of two times greater than the 3 km air tower. It is not surprising, because the helium is lighter than air and it provides a lift force. The cover thickness changes from 0.08 mm (at the base) to 0.42 mm at an altitude of 9 km and decreases to 0.2 mm at 30 km. The outer cover mass is about 370 tons. Required helium mass is 190 tons.

**Project 3. Air-hydrogen tower 100 km.** (Base radius of air part is 25 m, the hydrogen part has base radius 5 m). This tower is in two parts. The lower part (0–15 km) is filled with air. The top part (15–100 km) is filled with hydrogen. It makes this tower safer, because the low atmospheric pressure at high altitude decreases the probability of fire. Both parts may be used for tourists.

*Air part, 0–15 km.* The base radius is 25 m, the additional pressure is 0.1 atm, average temperature is 240 °K, and the stress coefficient  $K = 0.1$ . Change of radius is  $25 \div 16$  m, the useful

tower lift force is 90 tons, and the tower outer tower cover thickness is  $0.43 \div 0.03$  mm; maximum safe bending moment is  $(0.5 \div 0.03) \times 10^4$  ton $\times$ meter; the cover mass is 570 tons. This tower can be used for tourism and as an astronomy observatory. For  $K = 0.1$ , the lower (0 $\div$ 15 km) part of the project requires 570 tons of outer cover and provides 90 tons of useful top lift force.

*Hydrogen part, 15–100 km.* This part has base radius 5 m, additional gas pressure 0.1 atm, and requires a stronger cover, with  $K = 0.2$ .

The results of computation are presented in the following figures: the tower radius versus altitude is  $5 \div 1.4$  m; the tower thickness is  $0.06 \div 0.013$  mm; the cover mass is 112 tons; the lift force is 5 ton; hydrogen mass is 40 tons.

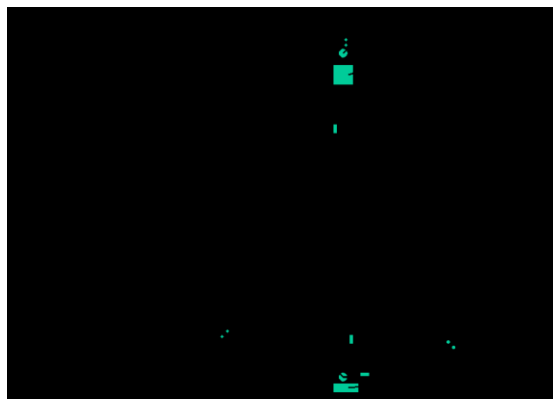
The useful top tower load can be about 5 tons, maximum, for  $K = 0.2$ . The cover mass is 112 tons, the hydrogen lift force is 37 tons. The top tower will press on the lower part with a force of only  $112 - 37 + 5 = 80$  tons. The lower part can support 90 tons.

The proposed projects use the optimal change of radius, but designers must find the optimal combination of the air and gas parts and gas pressure.

### 3. Circle (centrifugal) Space Towers [16 - 17]

Description of Circle (centrifugal) Tower (Space Keeper).

The installation includes (Fig.3): a closed-loop cable made from light, strong material (such as artificial fibers, whiskers, filaments, nanotubes, composite material) and a main engine, which rotates the cable at a fast speed in a vertical plane. The centrifugal force makes the closed-loop cable a circle. The cable circle is supported by two pairs (or more) of guide cables, which connect at one end to the cable circle by a sliding connection and at the other end to the planet's surface. The installation has a transport (delivery) system comprising the closed-loop load cables (chains), two end rollers at the top and bottom that can have medium rollers, a load engine and a load. The top end of the transport system is connected to the cable circle by a sliding connection; the lower end is connected to a load motor. The load is connected to the load cable by a sliding control connection.

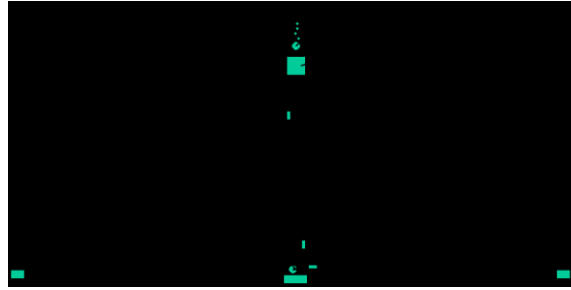


**Fig.3.** Circle launcher (space station keeper) and space transport system. *Notations:* 1 – cable circle, 2 – main engine, 3 – transport system, 4 – top roller, 5 – additional cable, 6 – the load (space station), 7 – mobile cabin, 8 – lower roller, 9 – engine of the transport system.

The installation can have the additional cables to increase the stability of the main circle, and the transport system can have an additional cable in case the load cable is damaged.

The installation works in the following way. The main engine rotates the cable circle in the vertical plane at a sufficiently high speed so the centrifugal force becomes large enough to it lifts the cable and transport system. After this, the transport system lifts the space station into space.

The first modification of the installation is shown in Fig. 4. There are two main rollers 20, 21. These rollers change the direction of the cable by 90 degrees so that the cable travels along the diameter of the circle, thus creating the form of a semi-circle. It can also have two engines. The other parts are same.



**Fig. 4.** Semi-circle launcher (space station keeper) and transport system. Notation is the same with Fig. 3.1 with the additional 20 and 21 – rollers. The semi-circles are same.

**PROJECT 1. SPACE STATION FOR TOURISTS OR A SCIENTIFIC LABORATORY AT AN ALTITUDE OF 140 KM (FIGS.4).** THE CLOSED-LOOP CABLE IS A SEMI-CIRCLE. THE RADIUS OF THE CIRCLE IS 150 KM. THE SPACE STATION IS A CABIN WITH A WEIGHT OF 4 TONS (9000 LB) AT AN ALTITUDE OF 150 KM (94 MILES). THIS ALTITUDE IS 140 KM UNDER LOAD. The results of computations for three versions (different cable strengths) of this project are in Table 1.

**Table 1.** Results of computation of Project 1.

Variant	$\sigma$ , kg/mm <sup>2</sup>	$\gamma$ , kg/m <sup>3</sup>	$K = \sigma/\gamma/10^7$	$V_{max}$ , km/s	$H_{max}$ , km	$S$ , mm <sup>2</sup>
1	2	3	4	5	6	7
1	8300	1800	4.6	6.8	2945	1
2	7000	3500	2.0	4.47	1300	1
3	500	1800	0.28	1.67	180	100

$P_{max}$ [tons]	$G$ , kg	Lift force, kg/m	Loc. Load, kg	$L$ , km	$\alpha^0$	$\Delta H$ , km
8	9	10	11	12	13	14
30	1696	0.0634	4000	63	13.9	5.0
12.5	3282	0.0265	4000	151	16.6	7.2
30.4	170x10 <sup>3</sup>	0.0645	4000	62	4.6	0.83

Cable Thrust $T_{max}$ , kg,	Cable drag $H = 0$ km, kg	Cable drag $H = 4$ km, kg	Power MW $H = 0$ km	PowerMW $H = 4$ km	Max.Tourists men/day
15	16	17	18	19	20
8300	2150	1500	146	102	800
7000	1700	1100	76	49	400
50000	7000	5000	117	83.5	800

The column numbers are: 1) the number of the variant; 2) the permitted maximum tensile strength [kg/mm<sup>2</sup>]; 3) the cable density [kg/m<sup>3</sup>]; 4) the ratio  $K = \sigma/\gamma 10^{-7}$ ; 5) the maximum cable speed [km/s] for a given tensile strength; 6) the maximum altitude [km] for a given tensile strength; 7) the cross-sectional area of the cable [mm<sup>2</sup>]; 8) the maximum lift force of one semi-circle [ton]; 9) the weight of the two semi-circle cable [kg]; 10) the lift force of one meter of cable [kg/m]; 11) the local load (4 tons or 8889 lb); 12) the length of the cable

required to support the given (4 tons) load [km]; 13) the cable angle to the horizon near the local load [degrees]; 14) the change of altitude near the local load; 15) the maximum cable thrust [kg]; 16) the air drag on one semi-circle cable if the driving (motor) station is located on the ground (at altitude  $H = 0$ ) for a half turbulent boundary layer; 17) the air drag of the cable if the drive station is located on a mountain at  $H = 4$  km; 18) the power of the drive stations [MW] (two semi-circles) if located at  $H = 0$ ; 19) the power of the drive stations [MW] if located at  $H = 4$  km; 20) the number of tourists (tourist capacity) per day (0.35 hour in station) for double semi-circles.

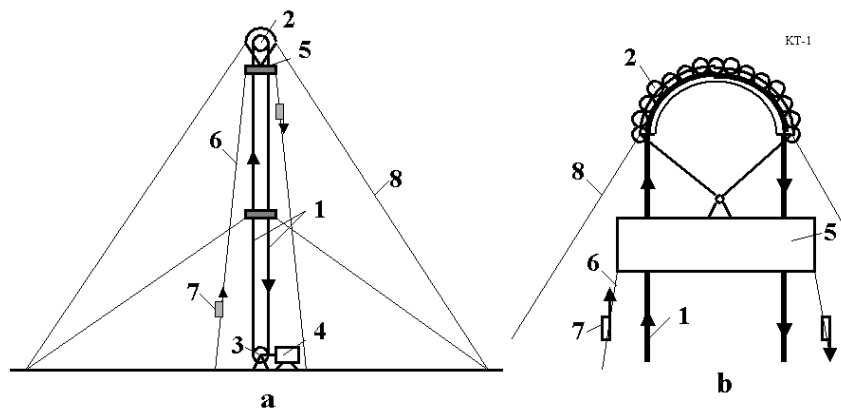
#### Discussion of Project 1.

- 1) The first variant has a cable diameter of 1.13 mm (0.045 inches) and a general cable weight of 1696 kg (3658 lb). It needs a power (engine) station to provide from 102 to a maximum of 146 MW (the maximum amount is needed for additional research).
- 2) The second variant needs the engine power from 49 to 76 MW.
- 3) The third variant uses a cable with tensile strength near that of current fibers. The cable has a diameter of 11.3 mm (0.45 inches) and a weight of 170 tons. It needs an engine to provide from 83.5 to 117 MW.

The systems may be used for launching (up to 1 ton daily) satellites and interplanetary probes. The installation may be used as a relay station for TV, radio, and telephones.

### 4. Kinetic and Cable Space Tower [13-15].

The installation includes (see notations in Fig.5): a strong closed-loop cable, rollers, any conventional engine, a space station (top platform), a load elevator, and support stabilization cables (expansions). The installation works in the following way. The engine rotates the bottom roller and permanently moves the closed-loop cable at high speed. The cable reaches a top roller at high altitude, turns back and moves to the bottom roller. When the cable turns back it creates a reflected (centrifugal) force. This force can easily be calculated using centrifugal theory, or as reflected mass using a reflection (momentum) theory. The force keeps the space station suspended at the top roller; and the cable (or special cabin) allows the delivery of a load to the space station. The station has a parachute that saves people if the cable or engine fails.



**Fig.5. a.** Offered kinetic tower: 1 – mobile closed loop cable, 2 – top roller of the tower, 3 – bottom roller of the tower, 4 – engine, 5 – space station, 6 – elevator, 7 – load cabin, 8 – tensile element (stabilizing rope).  
**b.** Design of top roller.

The theory shows, that current widely produced artificial fibers allow the cable to reach altitudes up to 100 km (see Projects 1 and 2 in [14]). If more altitude is required a multi-stage tower must be used (see Project 3 in [14]). If a very high altitude is needed (geosynchronous orbit or more), a very strong cable made from nanotubes must be used (see Project 4 in [14]).

The tower may be used for a horizon launch of the space apparatus. The vertical kinetic towers support horizontal closed-loop cables rotated by the vertical cables. The space apparatus is lifted by the vertical cable, connected to horizontal cable and accelerated to the required velocity.

The closed-loop cable can have variable length. This allows the system to start from zero altitude, and gives its workers/users the ability to increase the station altitude to a required value, and to spool the cable for repair. The innovation device for this action is shown in Fig. 8-6 [14]. The spool can reel up and unreel in the left and right branches of the cable at different speeds and can alter the length of the cable.

The safety speed of the cable spool is same with the safety speed of cable because the spool operates as a free roller. The conventional rollers made from the composite cable material have same safety speed with cable. The suggested spool is an innovation because it is made only from cable (no core) and it allows reeling up and unreeling simultaneously with different speed. That is necessary for change the tower altitude.

The small drive rollers press the cable to main (large) drive roller, provide a high friction force between the cable and the drive rollers and pull (rotate) the cable loop.

**Project 1. Kinetic Tower of Height 4 km.** For this project is taken a conventional artificial fiber widely produced by industry with the following cable performances: safety stress is  $\sigma = 180 \text{ kg/mm}^2$  (maximum  $\sigma = 600 \text{ kg/mm}^2$ , safety coefficient  $n = 600/180 = 3.33$ ), density is  $\gamma = 1800 \text{ kg/m}^3$ , cable diameter  $d = 10 \text{ mm}$ .

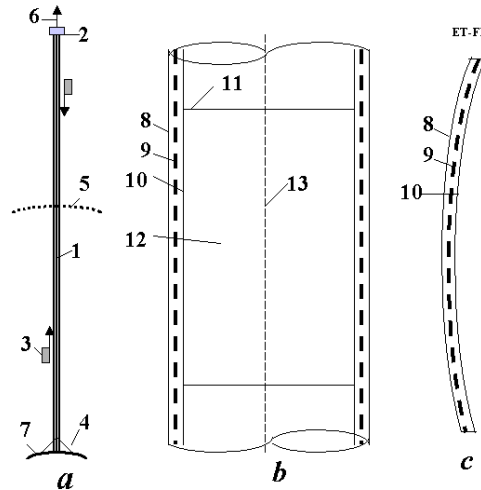
The special stress is  $k = \sigma/\gamma = 10^6 \text{ m}^2/\text{s}^2$  ( $K = k/10^7 = 0.1$ ), safe cable speed is  $V = k^{0.5} = 1000 \text{ m/s}$ , the cable cross-section area is  $S = \pi d^2/4 = 78.5 \text{ mm}^2$ , useful lift force is  $F = 2S\gamma(k-gH) = 27.13 \text{ tons}$ . Requested engine power is  $P = 16 \text{ MW}$  (Eq. (10), [15]), cable mass is  $M = 2S\gamma H = 2 \cdot 78.5 \cdot 10^{-6} \cdot 1800 \cdot 4000 = 1130 \text{ kg}$ .

## 5. Electrostatic Space Tower [18]-[19].

**1. Description of Electrostatic Tower.** The offered electrostatic space tower (or mast, or space elevator) is shown in fig.6. That is inflatable cylinder (tube) from strong thin dielectric film having variable radius. The film has inside the sectional thin conductive layer 9. Each section is connected with issue of control electric voltage. In inside the tube there is the electron gas from free electrons. The electron gas is separated by in sections by a thin partition 11. The layer 9 has a positive charge equals a summary negative charge of the inside electrons. The tube (mast) can have the length (height) up Geosynchronous Earth Orbit (GEO, about 36,000 km) or up 120,000 km (and more) as in project (see below). The very high tower allows to launch free (without spend energy in launch stage) the interplanetary space ships. The offered optimal tower is design so that the electron gas in any cross-section area compensates the tube weight and tube does not have compressing longitudinal force from weight. More over the tower has tensile longitudinal (lift) force which allows the tower has a vertical position. When the tower has height more GEO the additional centrifugal force of the rotate Earth provided the vertical position and natural stability of tower.

The bottom part of tower located in troposphere has the bracing wires 4 which help the tower to resist the troposphere wind.

The control sectional conductivity layer allows to create the high voltage running wave which accelerates (and brakes) the cabins (as rotor of linear electrostatic engine) to any high speed. Electrostatic forces also do not allow the cabin to leave the tube.



**Fig.6.** Electrostatic AB tower (mast, Space Elevator). (a) Side view, (b) Cross-section along axis, (c) Cross-section wall perpendicular axis. *Notations:* 1 - electrostatic AB tower (mast, Space Elevator); 2 - Top space station; 3 - passenger, load cabin with electrostatic linear engine; 4 - bracing (in troposphere); 5 - geosynchronous orbit; 6 - tensile force from electron gas; 7 - Earth; 8 - external layer of isolator; 9 - conducting control layer having sections; 10 - internal layer of isolator; 11 - internal dielectric partition; 12 - electron gas, 13 - laser control beam.

**2. Electron gas and AB tube.** The electron gas consists of conventional electrons. In contrast to molecular gas the electron gas has many surprising properties. For example, electron gas (having same mass density) can have the different pressure in the given volume. Its pressure depends from electric intensity, but electric intensity is different in different part of given volume. For example, in our tube the electron intensity is zero in center of cylindrical tube and maximum at near tube surface.

The offered AB-tube is main innovation in the suggested tower. One has a positive control charges isolated thin film cover and electron gas inside. The positive cylinder create the zero electric field inside the tube and electron conduct oneself as conventional molecules that is equal mass density in any points. When kinetic energy of electron is less then energy of negative ionization of the dielectric cover or the material of the electric cover does not accept the negative ionization, the electrons are reflected from cover. In other case the internal cover layer is saturated by negative ions and begin also to reflect electrons. Impotent also that the offered AB electrostatic tube has neutral summary charge in outer space.

**Advantages of electrostatic tower.** The offered electrostatic tower has very important advantages in comparison with space elevator:

1. Electrostatic AB tower (mast) may be built from Earth's surface without rockets. That decreases the cost of electrostatic mast in thousands times.
2. One can have any height and has a big control load capacity.
3. In particle, electrostatic tower can have the height of a geosynchronous orbit (37,000 km) WITHOUT the additional continue the space elevator (up 120,000 ÷ 160,000 km) and counterweight (equalizer) of hundreds tons.
4. The offered mast has less the total mass in tens of times then conventional space elevator.
5. The offered mast can be built from lesser strong material then space elevator cable (comprise the computation here and in [13] Ch.1).
6. The offered tower can have the high speed electrostatic climbers moved by high voltage electricity from Earth's surface.



7. The offered tower is more safety against meteorite then cable space elevator, because the small meteorite damaged the cable is crash for space elevator, but it is only create small hole in electrostatic tower. The electron escape may be compensated by electron injection.
8. The electrostatic mast can bend in need direction when we give the electric voltage in need parts of the mast.

The electrostatic tower of height  $100 \div 500$  km may be built from current artificial fiber material in present time. The geosynchronous electrostatic tower needs in more strong material having a strong coefficient  $K \geq 2$  (whiskers or nanotubes, see below).

### 3. Other applications of offered AB tube idea.

The offered AB-tube with the positive charged cover and the electron gas inside may find the many applications in other technical fields. For example:

- 1) *Air dirigible.* (1) The airship from the thin film filled by an electron gas has 30% more lift force then conventional dirigible filled by helium. (2) Electron dirigible is significantly cheaper then same helium dirigible because the helium is very expensive gas. (3) One does not have problem with changing the lift force because no problem to add or to delete the electrons.
- 2) *Long arm.* The offered electron control tube can be used as long control work arm for taking the model of planet ground, rescue operation, repairing of other space ships and so on [13] Ch.9.
- 3) *Superconductive or closed to superconductive tubes.* The offered AB-tube must have a very low electric resistance for any temperature because the electrons into tube to not have ions and do not loss energy for impacts with ions. The impact the electron to electron does not change the total impulse (momentum) of couple electrons and electron flow. If this idea is proved in experiment, that will be big breakthrough in many fields of technology.
- 4) *Superreflectivity.* If free electrons located between two thin transparency plates, that may be superreflectivity mirror for widely specter of radiation. That is necessary in many important technical field as light engine, multy-reflect propulsion [13] Ch.12 and thermonuclear power [21] Ch.11.

The other application of electrostatic ideas is Electrostatic solar wind propulsion [13] Ch.13, Electrostatic utilization of asteroids for space flight [13] Ch.14, Electrostatic levitation on the Earth and artificial gravity for space ships and asteroids [13, Ch.15], Electrostatic solar sail [13] Ch.18, Electrostatic space radiator [13] Ch.19, Electrostatic AB ramjet space propulsion [20], etc.[21].

**Project.** As the example (not optimal design!) author of [19] takes three electrostatic towers having: the base (top) radius  $r_0 = 10$  m;  $K = 2$ ; heights  $H = 100$  km, 36,000 km (GEO); and  $H = 120,000$  km (that may be one tower having named values at given altitudes); electric intensity  $E = 100$  MV/m and 150 MV/m. The results of estimation are presented in Table 2.

**Table 2.** The results of estimation main parameters of three AB towers (masts) having the base (top) radius  $r_0 = 10$  m and strength coefficient  $K = 2$  for two  $E = 100, 150$  MV/m.

Value	$E$ MV/m	$H=100$ km	$H=36,000$ km	$H=120,000$ km
Lower Radius , m	-	10	100	25
Useful lift force, ton	100	700	5	100
Useful lift force, ton	150	1560	11	180
Cover thickness, mm	100	$1 \times 10^{-2}$	$1 \times 10^{-3}$	$0.7 \times 10^{-2}$
Cover thickness, mm	150	$1.1 \times 10^{-2}$	$1.2 \times 10^{-3}$	$1 \times 10^{-2}$
Mass of cover, ton	100	140	$3 \times 10^3$	$1 \times 10^4$
Mass of cover, ton	150	315	$1 \times 10^4$	$2 \times 10^4$
Electric charge, C	100	$1.1 \times 10^4$	$3 \times 10^5$	$12 \times 10^5$
Electric charge, C	150	$1.65 \times 10^4$	$4.5 \times 10^5$	$1.7 \times 10^6$

**Conclusion.** The offered inflatable electrostatic AB mast has gigantic advantages in comparison with conventional space elevator. Main of them is follows: electrostatic mast can be built any height without rockets, one needs material in tens times less them space elevator. That means the electrostatic mast will be in hundreds times cheaper then conventional space elevator. One can be built on the Earth's surface and their height can be increased as necessary. Their base is very small.

The main innovations in this project are the application of electron gas for filling tube at high altitude and a solution of a stability problem for tall (thin) inflatable mast by control structure.

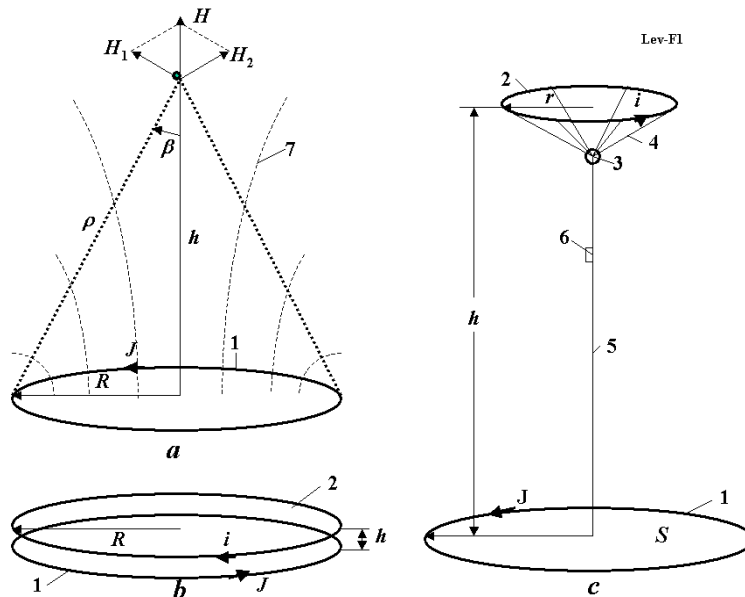
## 6. Electromagnetic Space Towers (AB-Levitron) [20].

The AB-Levitron uses two large conductive rings with very high electric current (fig.7). They create intense magnetic fields. Directions of the electric currents are opposed one to the other and the rings are repelling, one from another. For obtaining enough force over a long distance, the electric current must be very strong. The current superconductive technology allows us to get very high-density electric current and enough artificial magnetic field at a great distance in space.

The superconductive ring does not spend net electric energy and can work for a long time period, but it requires an integral cooling system because current superconducting materials have a critical temperature of about 150-180 K. This is a *cryogenic* temperature.

However, the present computations of methods of heat defense (for example, by liquid nitrogen) are well developed and the induced expenses for such cooling are small.

The ring located in space does not need any conventional cooling—there, defense from Sun and Earth radiations is provided by high-reflectivity screens. However, a ring in space must have parts open to outer space for radiating of its heat and support the maintaining of low ambient temperature. For variable direction of radiation, the mechanical screen defense system may be complex. However, there are thin layers of liquid crystals that permit the automatic control of their energy reflectivity and transparency and the useful application of such liquid crystals making it easier for appropriate space cooling system. This effect is used by new man-made glasses that can grow dark in bright solar light.



**Figure 7.** Explanation of AB-Levitron Tower. (a) Artificial magnetic field; (b) AB-Levitron from two same closed superconductivity rings; (c) AB-Levitron - motionless satellite, space station or communication mast. *Notation:* 1- ground superconductivity ring; 2 - levitating ring; 3 - suspended stationary satellite

(space station, communication equipment, etc.); 4 - suspension cable; 5 - elevator (climber) and electric cable; 6 - elevator cabin; 7 - magnetic lines of ground ring;  $R$  - radius of lower (ground) superconductivity ring;  $r$  - radius of top ring;  $h$  - altitude of top ring;  $H$  - magnetic intensity;  $S$  - ring area.

The most important problem of the AB-Levitron is the stability of the top ring. The top ring is in equilibrium, but it is out of balance when it is not parallel to the ground ring. Author offers to suspend a load (satellite, space station, equipment, etc) lower than this ring plate. In this case, a center of gravity is lower a net lift force and the system then become stable.

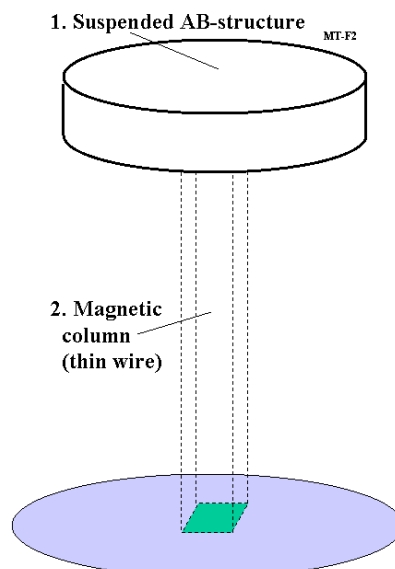
For mobile vehicles the AB-Levitron can have a running-wave of magnetic intensity which can move the vehicle (produce electric current), making it significantly mobile in the traveling medium.

**Project #1. Stationary space station at altitude 100 km.** The author of [20] estimates the stationary space station located at altitude  $h = 100$  km. He takes the initial data: Electric current in the top superconductivity ring is  $i = 10^6$  A; radius of the top ring is  $r = 10$  km; electric current in the superconductivity ground ring is  $J = 10^8$  A; density of electric current is  $j = 10^6$  A/mm<sup>2</sup>; specific mass of wire is  $\gamma = 7000$  kg/m<sup>3</sup>; specific mass of suspending cable and lift (elevator) cable is  $\gamma = 1800$  kg/m<sup>3</sup>; safety tensile stress suspending and lift cable is  $\sigma = 1.5 \times 10^9$  N/m<sup>2</sup> = 150 kg /mm<sup>2</sup>;  $\alpha = 45^\circ$ , safety superconductivity magnetic intensity is  $B = 100$  T. Mass of lift (elevator) cabin is 1000 kg.

Then the optimal radius of the ground ring is  $R = 81.6$  km (Eq. (3)[20], we can take  $R = 65$  km); the mass of space station is  $M_S = F = 40$  tons (Eq.(2)). The top ring wire mass is 440 kg or together with control screen film is  $M_r = 600$  kg. Mass of two-cable elevator is 3600 kg; mass of suspending cable is less 9600 kg, mass of parachute is 2200 kg. As the result the useful mass of space station is  $M_u = 40 - (0.6+1+3.6+9.6+2.2) = 23$  tons.

Minimal wire radius of top ring is  $R_T = 2$  mm (Eq. (10)[20]). If we take it  $R_T = 4$  mm the magnetic pressure will be  $P_T = 100$  kg/mm<sup>2</sup>. Minimal wire radius of the ground ring is  $R_T = 0.2$  m. If we take it  $R_T = 0.4$  m the magnetic pressure will be  $P_T = 100$  kg/mm<sup>2</sup>. Minimal rotation speed (take into consideration the suspending cable) is  $V = 645$  m/s, time of one revolution is  $t = 50$  sec. Electric energy in the top ring is small, but in the ground ring is very high  $E = 10^{14}$  J. That is energy of 2500 tons of liquid fuel (such as natural gas, methane).

The requisite power of the cooling system for ground ring is about  $P = 30$  kW.



**Fig.8.** Suspended Magnetic AB-Structure

**2. Magnetic Suspended AB-Structures** [22]. These structures use the special magnetic AB-columns [Fig. 8]. Author of [22] computed two projects: suspended moveless space station at altitude 100 km and the geosynchronous space station at altitude 37,000 km. He shows that space stations may be cheap launched by current technology (magnetic force without rockets) and climber can have a high speed.

As the reader observes, all parameters are accessible using existing and available technology. They are not optimal.

### General conclusion

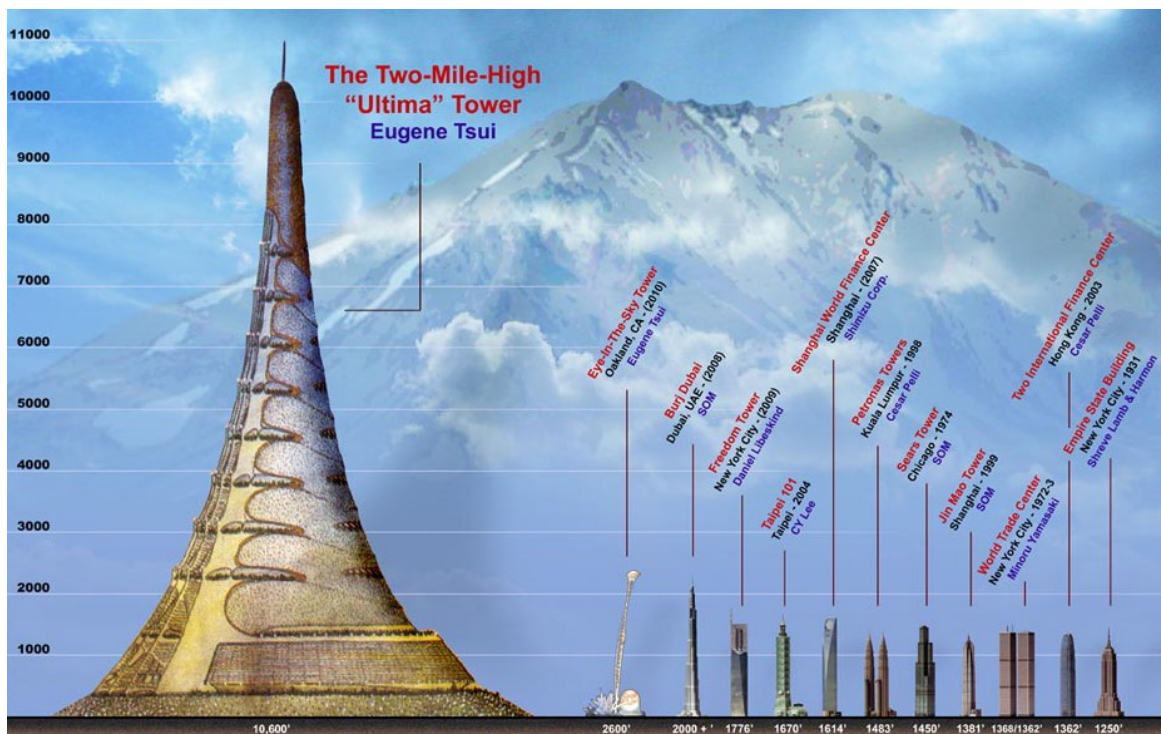
Current technology can build the high height and space towers (mast). We can start an inflatable or steel tower having the height 3 km. This tower is very useful (profitable) for communication, tourism and military. The inflatable tower is significantly cheaper (in ten times) than a steel tower, but it is having a lower life times (up 30-50 years) in comparison the steel tower having the life times 100 – 200 years. The new advance materials can change this ratio and will make very profitable the high height towers. The circle, kinetic, electrostatic and magnetic space towers promise a jump in building of space towers but they are needed in R&D. The information about the current tallest structures the reader find in [23].

### References

Many works noted below the reader can find on site Cornell University <<http://arxiv.org/>> and <<http://www.scribd.com>> search "Bolonkin", site <<http://bolonkin.narod.ru/p65.htm>> and in Conferences 2002-2006 (see, for example, Conferences AIAA, <http://aiaa.org> <<http://aiaa.org/>> , search "Bolonkin")

1. D.V. Smitherman, Jr., "Space Elevators", NASA/CP-2000-210429.
2. K.E. Tsiolkovski:"Speculations Abot Earth and Sky on Vesta", Moscow, Izd-vo AN SSSR, 1959; Grezi o zemle i nebe (in Russian), Academy of Sciences, USSR., Moscow, p. 35, 1999.
3. Geoffrey A. Landis, Craig Cafarelli, The Tsiolkovski Tower Re-Examined, *JBIS*, Vol. 32, p. 176–180, 1999.
4. Y. Artsutanov. Space Elevator, [http://www.liftport.com/files/Artsutanov\\_Pravda\\_SE.pdf](http://www.liftport.com/files/Artsutanov_Pravda_SE.pdf).
5. A.C. Clarke: *Fountains of Paradise*, Harcourt Brace Jovanovich, New York, 1978.
6. Bolonkin A.A., (2006). Optimal Solid Space Tower, Paper AIAA-2006-7717, ATIO Conference, 25-27 Sept.,2006, Wichita, Kansas, USA, <http://arxiv.org/ftp/physics/papers/0701/0701093.pdf> . See also paper AIAA-2006-4235 by A. Bolonkin.
7. Bolonkin A.A. (2007), Optimal Rigid Space Tower, Paper AIAA-2007-367, 45th Aerospace Science Meeting, Reno, Nevada, 8-11 Jan.,2007, USA. <http://aiaa.org> search "Bolonkin".
8. Book "*New Concepts, Ideas and Innovation in Aerospace*", NOVA, 2008, Ch.9, "Optimal Solid Space Tower", pp.161-172. <http://www.scribd.com/doc/24057071> .
9. Bolonkin A.A.,(2002), "*Optimal Inflatable Space Towers of High Height*", COSPAR-02 C1. 10035-02, 34th Scientific Assembly of the Committee on Space Research (COSPAR). The Wold Space Congress - 2002, 10 -19 Oct. 2002, Houston, Texas, USA.
10. Bolonkin A.A. (2003),*Optimal Inflatable Space Towers with 3 -100 km Height*", *JBIS*, Vol.56,No.3/4, pp.87-97, 2003. <http://Bolonkin.narod.ru/p65.htm> .
11. Book "Non-Rocket Space Launch and Flight", by A.Bolonkin, Elsevier. 2006, Ch.4 "Optimal Inflatable Space Towers", pp.83-106; <http://www.scribd.com/doc/24056182> , <http://Bolonkin.narod.ru/p65.htm> .
12. Book "Macro-Engineering: Environment and Technology", Ch.1E "Artificial Mountains", pp. 299-334, NOVA, 2008. <http://Bolonkin.narod.ru/p65.htm>, <http://www.scribd.org> , search term "Bolonkkin".
13. Book "Non-Rocket Space Launch and Flight", Elsevier. 2006, Ch. 9 "Kinetic Anti-Gravotator", pp. 165-186; <http://Bolonkin.narod.ru/p65.htm>, <http://www.scribd.com/doc/24056182> ; Main idea of this Chapter was presented as papers COSPAR-02, C1.1-0035-02 and IAC-02-IAA.1.3.03, 53<sup>rd</sup> International Astronautical Congress. The World Space Congress-2002, 10-19 October 2002, Houston, TX, USA, and the

- full manuscript was accepted as AIAA-2005-4504, 41<sup>st</sup> Propulsion Conference, 10-12 July 2005, Tucson, AZ, USA. <http://aiaa.org> search “Bolonkin”.
14. Book "Non-Rocket Space Launch and Flight", Elsevier. 2006, Ch.5 “*Kinetic Space Towers*”, pp. 107-124, Springer, 2006. <http://Bolonkin.narod.ru/p65.htm> or <http://www.scribd.com/doc/24056182>.
  15. “*Transport System for Delivery Tourists at Altitude 140 km*”, manuscript was presented as Bolonkin’s paper IAC-02-IAA.1.3.03 at the World Space Congress-2002, 10-19 October, Houston, TX, USA. <http://Bolonkin.narod.ru/p65.htm>,
  16. Bolonkin A.A. (2003), “*Centrifugal Keeper for Space Station and Satellites*”, JBIS, Vol.56, No. 9/10, 2003, pp. 314-327. <http://Bolonkin.narod.ru/p65.htm>.
  17. Book "Non-Rocket Space Launch and Flight", by A.Bolonkin, Elsevier. 2006, Ch.3 “*Circle Launcher and Space Keeper*”, pp.59-82. <http://www.scribd.com/doc/24056182>,
  18. Bolonkin A.A. (2007), “*Optimal Electrostatic Space Tower*”, Presented as Paper AIAA-2007-6201 to 43<sup>rd</sup> AIAA Joint Propulsion Conference, 8-11 July 2007, Cincinnati, OH, USA. <http://aiaa.org> search “Bolonkin”. See also “*Optimal Electrostatic Space Tower*” in: <http://arxiv.org/ftp/arxiv/papers/0704/0704.3466.pdf>,
  19. Book "New Concepts, Ideas and Innovation in Aerospace", NOVA, 2008, Ch. 11 “*Optimal Electrostatic Space Tower (Mast, New Space Elevator)*”, pp.189-204. <http://www.scribd.com/doc/24057071>.
  20. Book "New Concepts, Ideas and Innovation in Aerospace", NOVA, 2008, Ch.12, pp.205-220 “*AB Levitrons and Their Applications to Earth’s Motionless Satellites*”. (About *Electromagnetic Tower*). <http://www.scribd.com/doc/24057071>.
  21. Book "Macro-Projects: Environment and Technology”, NOVA, 2008, Ch.12, pp.251-270, “*Electronic Tubes and Quasi-Superconductivity at Room Temperature*”, (about *Electronic Towers*). <http://www.scribd.com/doc/24057930>, <http://Bolonkin.narod.ru/p65.htm>.
  22. Bolonkin A.A., Magnetic Suspended AB-Structures and Moveless Space Satellites. <http://www.scribd.com/doc/25883886>
  23. *Wikipedia*. Some background material in this article is gathered from Wikipedia under the Creative Commons license. <http://wikipedia.org>.



Solid high altitude tower and project





Tower fantasy



## Chapter 14

# Review of new ideas, innovation of non-rocket propulsion systems for Space Launch and Flight (Part 1)

### Abstract

In the past years the author and other scientists have published a series of new methods which promise to revolutionize the space propulsion systems, space launching and flight. These include the cable propulsion system, circle propulsion system and space keeper, kinetic propulsion system, gas-tube propulsion system, sliding rotary method, asteroid employment, electromagnetic accelerator, Sun and magnetic sail, solar wind sail, radioisotope sail, electrostatic space sail, laser beam propulsion system, kinetic anti-gravitator (repulsator), Earth-Moon non-rocket and Earth-Mars non-rocket transport system, multi-reflective beam propulsion system, electrostatic levitation, etc.

Some of them have the potential to decrease launch costs thousands of time, other allow to change the speed and direction of space apparatus without the spending of fuel.

The author reviews and summarizes some revolutionary propulsion systems for scientists, engineers, inventors, students and the public.

**Key words:** Review, Non-rocket propulsion, non-rocket space launching, non-rocket space flight, cable launch system, circle launch system, space keeper, kinetic propulsion system, gas-tube launch system, sliding rotary method, asteroid employment, electromagnetic accelerator, Sun and magnetic sail, solar wind sail, radioisotope sail, electrostatic space sail, laser beam propulsion system, kinetic anti-gravitator (repulsator), Earth-Moon non-rocket and Earth-Mars non-rocket transport system, multi-reflective beam propulsion system, electrostatic levitation, recombination engine, electronic sail, solar sail.

### Introduction

**Brief History.** People have long dreamed to reach the sky. The idea of building a tower high above the Earth into the heavens is very old [1],[6]. The Greed Pyramid of Gaza in Egypt constructed c.2570 BCE has a height 146 m. The writings of Moses, about 1450 BC, in Genesis, Chapter 11, refer to an early civilization that in about 2100 BC tried to build a tower to heaven out of brick and tar. This construction was called the Tower of Babel, and was reported to be located in Babylon in ancient Mesopotamia. Later in chapter 28, about 1900 BC, Jacob had a dream about a staircase or ladder built to heaven. This construction was called Jacob's Ladder. More contemporary writings on the subject date back to K.E. Tsiolkovski in his manuscript "Speculation about Earth and Sky and on Vesta," published in 1895 [2-3]. Idea of Space Elevator was suggested and developed Russian scientist Yuri Artsutanov and was published in the Sunday supplement of newspaper "Komsomolskaya Pravda" in 1960 [4]. This idea inspired Sir Arthur Clarke to write his novel, The Fountains of Paradise, about a Space Elevator located on a fictionalized Sri Lanka, which brought the concept to the attention of the entire world [5].

Rockets for military and recreational uses date back to at least 13th century China. Wernher von Braun, at the time a young aspiring rocket scientist, joined the military (followed by two former VfR members) and developed long-range weapons for use in World War II by Nazi Germany. In 1943, production of the V-2 rocket began in Germany. It had an operational range of 300 km (190



mi) and carried a 1,000 kg (2,200 lb) warhead, with an amatol explosive charge. It normally achieved an operational maximum altitude of around 90 km (56 mi), but could achieve 206 km (128 mi) if launched vertically.

After World War 2 the missile systems have received the great progress and achieved a great success. But rocket system is very expensive. In end of 1990 the researchers begin to study the non-rocket systems which promise to decrease the space launch and flight cost in hundreds times. The pioneer of these researches professor Alexander Bolonkin published the first serious book [1] in this field.

**Current status of non-rocket space launch and flight systems.** Over recent years interference-fit joining technology including the application of space methods has become important in the achievement of space propulsion system. Part results in the area of non-rocket space launch and flight methods have been patented recently or are patenting now.

Professor Bolonkin made a significant contribution to the study of the different types of non-rocket space launch and flight in recent years [1],[6]-[22] (1982-2011). Some of them are presented in given review.

Cable Space Launcher is researched in [1, pp.39-58]; Circle Launcher and Space Keeper were developed in [1, pp.59-82]; Kinetic Launcher and Kinetic Keeper were researched in [1, Ch.5, 9], [9], [10]; Gas tube hypersonic launcher presented in [1, pp.125-146]; Earth-Moon cable transport system was offered in [1, pp.147-156]; Earth-Mars cable transport system [1, pp.157-164]; Centrifugal space launchers were suggested in [1, pp.187-208, pp.223-244]; Asteroids as propulsion system of space ships were published in [1, pp.209-222]; Multi-reflex propulsion systems were researched in [1, pp.223-244]; Electrostatic Solar wind propulsion was developed in [1, pp.245-270]; Electrostatic utilization of asteroids as space propulsion in [1, pp.271-280]; Electrostatic levitation is presented in [1, pp.281-302]; Guided solar sail and energy generator is described in [1, pp.303-308]; Radioisotope space sail and electro-generator is presented in [1, pp.309-316]; Electrostatic solar sail is researched in [1, pp. 317-326]; Recombination space jet propulsion engine is described in [1, pp.327-340]; and Electronic sail is described in [1, pp.327-340]. Some of these systems were developed in [2]-[23].

Significant scientific, interplanetary and industrial use did not occur until the 20th century, when rocketry was the enabling technology of the Space Age, including setting foot on the moon.

But rockets are very expensive and have limited possibilities. In the beginning 21th century the researches of non-rocket launch and flight started [1], [5]-[8].Some of them are described in this review.

## **Main types of Non-Rocket Space Propulsion System**

Contents:

1. Cable Space Launcher
2. Circle Launcher and Space Keeper
3. Kinetic Launcher and Kinetic keeper
4. Gas tube hypersonic launcher
5. Earth-Moon cable transport system
6. Earth-Mars cable transport system
7. Centrifugal space launchers
8. Asteroids as propulsion system of space ships
9. Multi-reflex propulsion systems
10. Electrostatic Solar wind propulsion
11. Electrostatic utilization of asteroids as space propulsion
12. Electrostatic levitation

13. Guided solar sail and energy generator
14. Radioisotope space sail and electro-generator
15. Electrostatic solar sail
16. Recombination space jet propulsion engine
17. Electronic sail

## 1. Cable Space Launcher\*

A method and facilities for delivering payload and people into outer space are presented. This method uses, in general, engines and a cable located on a planetary surface. The installation consists of a space apparatus, power drive stations located along the trajectory of the apparatus, the cable connected to the apparatus and to the power stations, and a system for suspending the cable. The drive stations accelerate the apparatus up to hypersonic speed.

The estimations and computations show the possibility of making these projects a reality in a short period of time (two project examples are given: a launcher for tourists and a launcher for payloads). The launch will be very cheap at a projected cost of \$1–\$5 per pound. The cable is made from cheap artificial fiber widely produced by modern industry.

-----  
 \*This chapter was presented as Bolonkin's papers IAC-02-V.P.06, IAC-02-S.P.14 at World Space Congress-2002, Oct. 10–19, Houston, TX, USA, and as variant No. 8057 at symposium "The Next 100 years", 14–17 July 2003, Dayton, Ohio, USA; or see [1, pp.39-58].

**Brief Description.** The installation includes (see notations in Fig. 1.1): a cable; power drive stations; winged space apparatus (space ship, missile, probe, projectile and so on); conventional engines and flywheels; and a launching area (airdrome). Between drive stations the cable is supported by columns. The columns can also hold additional cables for future launches and a delivery system for used cable.

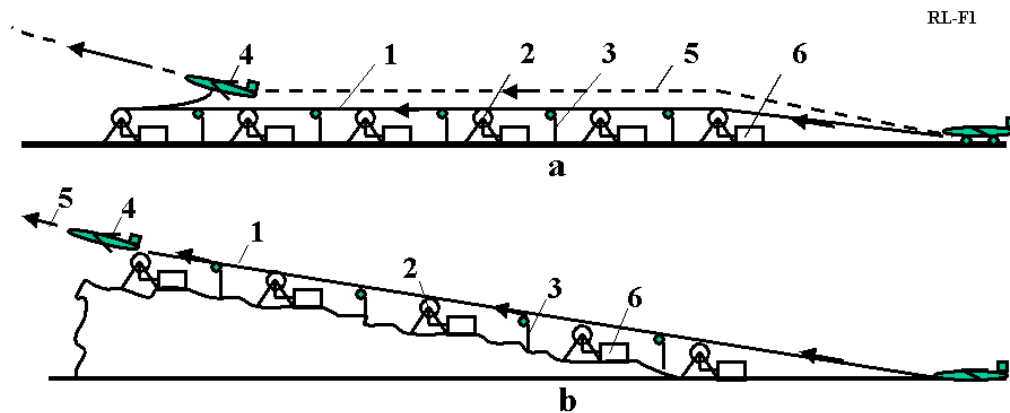


Fig. 1.1. *a.* Launcher for a crewed space ship with single cable. Notations: 1 – cable contains 3 parts: main part, outlet part, and directive part; 2 – power drive station; 3 – cable support columns; 4 – winged space apparatus (space ship, missile, probe, projectile and so on); 5 – trajectory of space apparatus; 6 – engine. *b.* A fixed slope small launcher for projectiles.

The installation works in the following way. All drive station start to run. The first power station pulls the cable, 1, connected to the winged space apparatus. The apparatus takes off from the start area and flies with acceleration along trajectory 5. When the apparatus reaches the first drive station, this drive station disconnects from the cable and the next drive station continues the apparatus acceleration, and

so on. At the end of the distance, the winged apparatus has reached hypersonic speed, disconnects from the cable, changes the horizontal acceleration into vertical acceleration (while it is flying in the atmosphere) and leaves the Earth's atmosphere.

. The power stations contain the engines. The engine can be any type, for example, gas turbines, or electrical or mechanical motors. The power drive station has also an energy storage system (flywheel accumulator of energy), a type transmission and a clutch. The installation can also have a slope and launch a projectile at an angle to horizon (Fig. 1.1b).

## 2. Circle Launcher and Space Keeper\*

The author proposes a new method and installation for flight in space. This method uses the centrifugal force of a rotating circular cable that provides a means to launch a load into outer space and to keep the stations fixed in space at altitudes at up to 200 km. The proposed installation may be used as a propulsion system for space ships and/or probes. This system uses the material of any space body for acceleration and changes to the space vehicle trajectory. The suggested system may also be used as a high capacity energy accumulator.

The article contains the theory of estimation and computation of suggested installations and four projects. Calculations include: a maximum speed given the tensile strength and specific density of a material, the maximum lift force of an installation, the specific lift force in planet's gravitation field, the admissible (safe) local load, the angle and local deformation of material in different cases, the accessible maximum altitudes of space cabins, the speed than a space ship can obtain from the installation, power of the installation, passenger elevator, etc. The projects utilize fibers, whiskers, and nanotubes produced by industry or in scientific laboratories.

-----  
 \* Detail manuscript was presented as Bolonkin's paper IAC-02-IAA.1.3.03 at the World Space Congress-2002, 10-19 October, Houston, TX, USA. The material is published in *JBIS*, vol. 56, No 9/10, 2003, pp. 314-327. See in [1, pp.59-82].

### *Short description of Circle Launcher.*

The installation includes (Fig. 2.1): a closed-loop cable made from light, strong material (such as artificial fibers, whiskers, filaments, nanotubes, composite material) and a main engine, which rotates the cable at a fast speed in a vertical plane. The centrifugal force makes the closed-loop cable a circle. The cable circle is supported by two pairs (or more) of guide cables, which connect at one end to the cable circle by a sliding connection and at the other end to the planet's surface. The installation has a transport (delivery) system comprising the closed-loop load cables (chains), two end rollers at the top and bottom that can have medium rollers, a load engine and a load. The top end of the transport system is connected to the cable circle by a sliding connection; the lower end is connected to a load motor. The load is connected to the load cable by a sliding control connection.

The installation can have the additional cables to increase the stability of the main circle, and the transport system can have an additional cable in case the load cable is damaged.

The installation works in the following way. The main engine rotates the cable circle in the vertical plane at a sufficiently high speed so the centrifugal force becomes large enough to it lifts the cable and transport system. After this, the transport system lifts the space station into space.

The first modification of the installation is shown in Fig. 2.2. There are two main rollers 20, 21. These rollers change the direction of the cable by 90 degrees so that the cable travels along the diameter of the circle, thus creating the form of a semi-circle. It can also have two engines. The other parts are same.

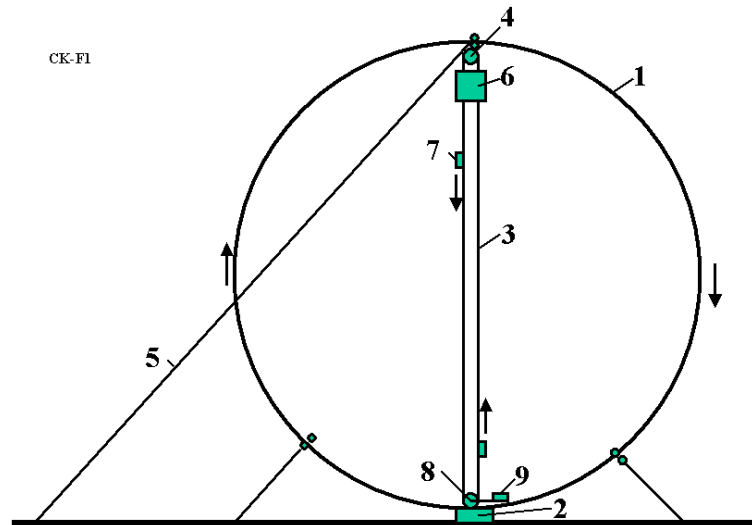


Fig. 2.1. Circle launcher (space station keeper) and space transport system. Notations are: 1 – cable circle, 2 – main engine, 3 – transport system, 4 – top roller, 5 – additional cable, 6 – the load (space station), 7 – mobile cabin, 8 – lower roller, 9 – engine of the transport system.

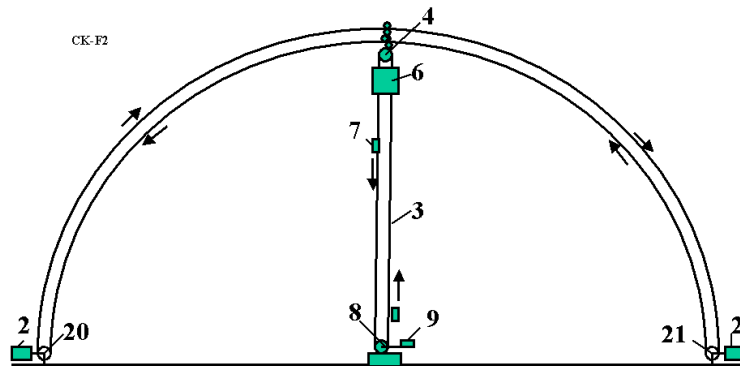


Fig. 2.2. Semi-circle launcher (space station keeper) and transport system. Notation is the same with Fig. 3.1 with the additional 20 and 21 – rollers. The semi-circle is the same (see right side of Fig. 3.4).

The installation can be used for the launch of a payload to outer space (Fig. 2.3). The load is connected to the cable circle by a sliding bearing through a brake. The load is accelerated by the cable circle, lifted to a high altitude, and disconnected at the top of the circle (semi-circle).

The installation may also be used as transport system for delivery of people and payloads from one place to another through space (Fig. 3.4 in [1]).

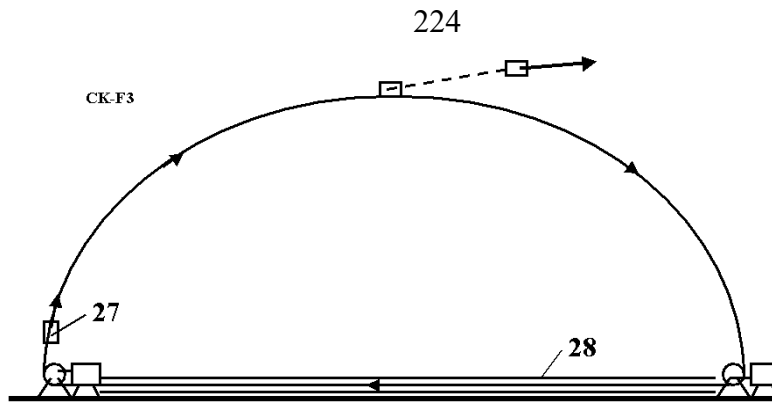


Fig. 2.3. Launching the space ship (probe) into space using cable semi-circle. 27 – load, 28 – vacuum tube (option).

This system works in the following way. The installation has two cable circles, which move in the opposite directions at the same speed. The space stations are connected to the cable circle through the sliding connection. They can move along the circle in any direction when they are connected to one of the cable circles through a friction clutch, transmission, gearbox, brake, and engine, and can use the transport system in Figs. 2.1 and 2.2 for climbing to or descending from the station. Because energy can be lost through friction in the connections, the energy transport system and drive rollers transfer energy to the cable circle from the planet surface. The cable circles are supported at a given position by the guide cables (see Project 2 in [1, Ch.3]). No towers for supporting the circle cable are needed.

The system can have only one cable (Figs. 2.1, 2.3).

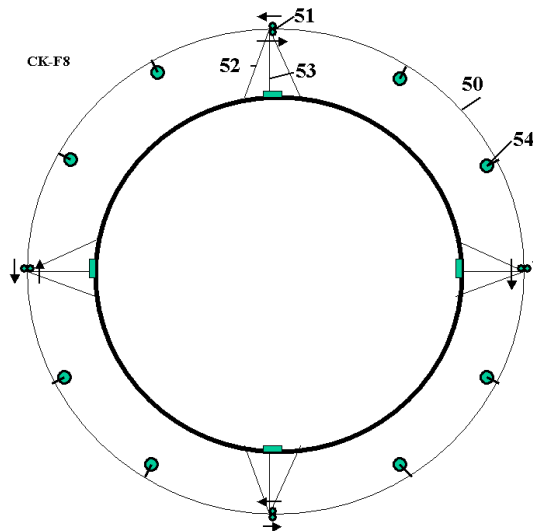


Fig. 2.4. Cable circle around the Earth for 8–10 space objects. Notations are: 50 – double circle, 51 – drive stations, 52 – guide cable, 53 – energy transport system, 54 – space station.

THE INSTALLATION CAN HAVE A SYSTEM FOR CHANGING THE RADIUS OF THE CABLE CIRCLE ([1], FIG. 3.9). WHEN AN OPERATOR MOVES THE TACKLE BLOCK, THE LENGTH OF THE CABLE CIRCLE IS CHANGED AND THE RADIUS OF THE CIRCLE IS ALSO CHANGED.

### 3. KINETIC LAUNCHER ON KINETIC TOWERS\*

The author discusses a revolutionary new method to access outer space. A cable stands up vertically and pulls up its payload into space with a maximum force determined by its strength. From the ground

the cable is allowed to rise up to the required altitude. After this, one can climb to an altitude using this cable or deliver a payload at altitude. The author shows how this is possible without infringing the law of gravity.

The original article contains the theory of the method and the computations for four projects for towers that are 4, 75, 225 and 160,000 km in height. The first three projects use the conventional artificial fiber widely produced by current industry, while the fourth project use nanotubes made in scientific laboratories. The chapter also shows in a fifth project how this idea can be used to launch a load at high altitude.

-----  
 \*Presented as paper IAC-02-IAA.1.3.03 at World Space Congress 2002, 10–19 October, Houston, TX, USA. Detail manuscript was published as Bolonkin, A.A. “Kinetic Space Towers and Launchers”, *JBIS*, Vol. 57, No.1/2, 2004, pp.33-39. Or see in [1, Ch.5, pp.107-124].

### Brief description of innovation.

The installation (kinetic tower) includes (see notations in Fig. 3-1a,b and others): a strong closed-loop cable, two rollers, any conventional engine, a space station, a load elevator, and support stabilization ropes.

The installation works in the following way. The engine rotates the bottom roller and permanently sends up the closed-loop cable at high speed. The cable reaches a top roller at high altitude, turns back and moves to the bottom roller. When cable turns back it creates a reflected (centrifugal) force. This force can easily be calculated using centrifugal theory, or as reflected mass using a reflection theory. The force keeps the space station suspended at the top roller; and the cable (or special elevator) allows the delivery of a load to the space station. The station has a parachute that saves people if the cable or engine fails.

The theory shows, that current widely produced artificial fibers (see References<sup>1</sup> for cable properties) allow the cable to reach altitudes up to 100 km (see Projects 1 and 2 in [1] Ch.5). If more altitude is required a multi-stage tower must be used ([1], Fig. 5.2, see also Project 3 in [1] Ch.5). If a very high altitude is needed (geosynchronous orbit or more), a very strong cable made from nanotubes must be used (see Project 4).

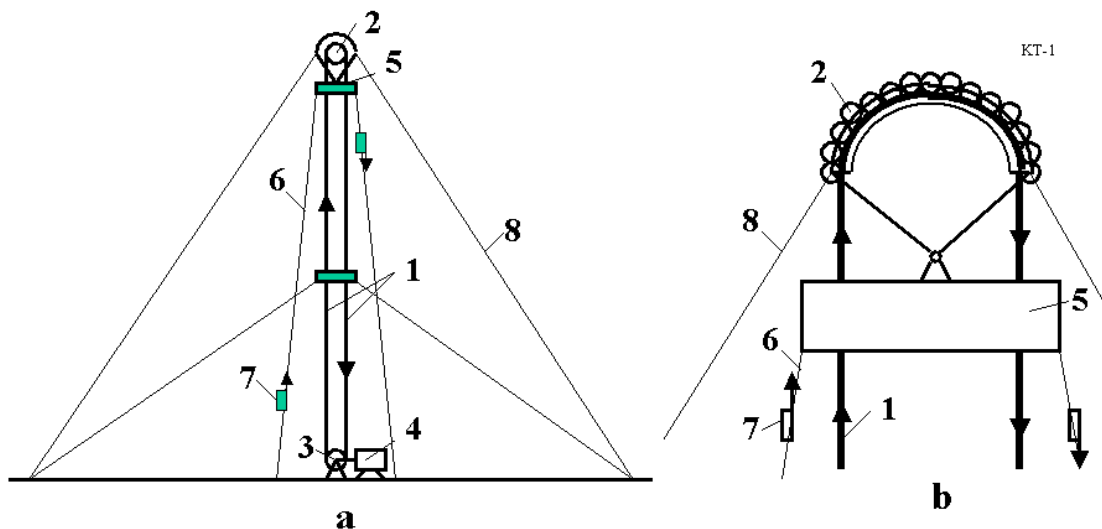


Fig. 3.1. **a.** Offered kinetic tower: 1 – mobile closed loop cable, 2 – top roller of the tower, 3 – bottom roller of the tower, 4 – engine, 5 – space station, 6 – elevator, 7 – load cabin, 8 – tensile element (stabilizing rope).  
**b.** Design of top roller.

The offered tower may be used for a horizon launch of the space apparatus (Fig. 3.2). The vertical kinetic towers support horizontal closed-loop cables rotated by the vertical cables. The space apparatus is lifted by the vertical cable, connected to horizontal cable and accelerated to the required velocity.

The closed-loop cable can have variable length. This allows the system to start from zero altitude, and gives the ability to increase the station altitude to a required value, and to spool the cable for repair. The device for this action is shown in [1], p.110, Fig. 5.4. The offered spool can reel in the left and right branches of the cable at different speeds and can change the length of the cable.

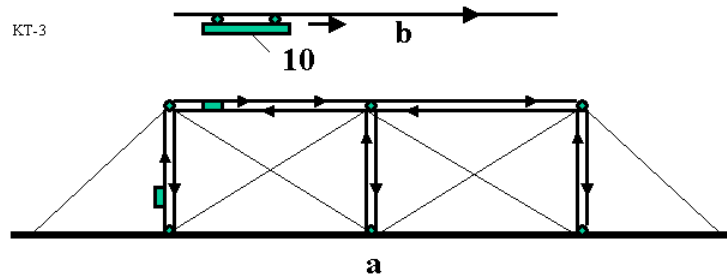


Fig. 3.2. a. Kinetic space installation with horizontally accelerated parts. b. 10 – accelerated missile.

#### 4. Gas Tube Hypersonic Launcher\*

The present review describes a hypersonic gas rocket, which uses tube walls as a moving compressed air container. Suggested burn programs (fuel injection) enable use of the internal tube components as a rocket. A long tube (up to 0.4–0.8 km) provides mobility and can be aimed in water. Relatively inexpensive oxidizer and fuel are used (compressed air or gaseous oxygen and kerosene). When a projectile crosses the Earth's atmosphere at an angle more than  $15^\circ$ , loss of speed and the weight of the required thermal protection system are small. The research shows that the launcher can give a projectile a speed of up to 5–8 km/s. The proposed launcher can deliver up to 85,000 tons of payloads to space annually at a cost of one to two dollars per pound of payload. The launcher can also deliver about 500 tons of mail or express parcels per day over continental distances and may be used as an energy station and accumulator. During war, this launch system could deliver military munitions to targets thousands to tens of thousands of kilometers away from the launch site.

-----  
 \* This review is based on a paper presented at the 38th AIAA Propulsion Conference, 7–10 July 2002, Indianapolis, USA (AIAA-2002-3927) and the World Space Congress, 10–19 Oct. 2002, Houston, USA (IAC-02-S.P.15). Detailed material is published as A.A.Bolonkin, "Hypersonic Gas-Rocket Launcher of High Capacity", *JBIS*, vol. 57, No. 5/6, 2004, pp. 162–172; *Journal Actual Problems of Aviation and Aerospace Systems*, Kazan, 1 (15), pp. 45-69, 2003.  
 See also in [1, Ch.6, pp.125-146].

#### Description

Fig. 4.1a shows a design of the tube of the suggested hypersonic gas-rocket system. The system is made up of a tube, a piston with a fuel tank and payload, and nozzle connected to the piston, and valves.

The tube rocket engine can be made without a special nozzle (Fig. 4.1b). In this case, the fuel efficiency of the gas-rocket engine will decrease but its construction becomes simpler.

The tube may be placed into a frame (Fig. 4.1c). The frame is placed into water and connected to a ship for mobility and aiming.



The launch sequence is as follows. First the movable piston with the fuel tank (containing liquid fuel), and payload are loaded into the tube. The piston is held in place by the fasteners or closed valve 17 (Fig. 4.1). The direction and angle of the launch tube are set.

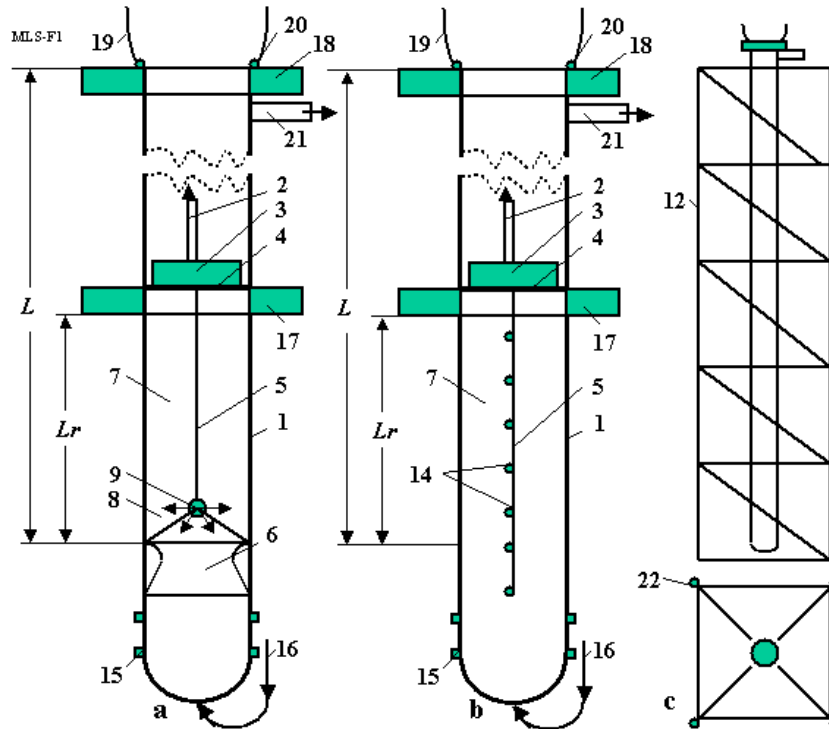


Fig. 4.1. a - Space launcher with the gas rocket and rocket nozzle in the tube. The system comprises the following: 1 – tube, 2 – payload (projectile), 3 – fuel tank, 4 – piston, 5 – fuel pipeline, 6 – nozzle connected to piston, 7 – rocket air column, 8 – combustion chamber, 9 – injectors of the combustion chamber, 12 – tube frame, 14 – additional injectors, 15 – lower tube injectors, 16 – air pipeline, 17 – lower valve, 18 – upper valve, 19 – top valve, 20 – air lock, 21 – gas pipe, 22 – electric engines. b - Space launcher with the gas rocket and no the rocket nozzle. c – Launcher in frame.

Valve 19 (Fig. 4.1) is closed and a vacuum (about 0.005 atm) is created in the launch tube space above the payload/piston to reduce the drag imparted to the payload/piston as it moves along the launch tube. The tube, of a length of 630 m and a diameter of 10 m, contains 61 tons of air at atmospheric pressure. If this air is not removed, the payload must be decreased by the same value. If air pressure is decreased down to 0.005 atm, the parasitic air mass is decreased to 300 kg. This is an acceptable parasitic load.

Valve 17 is closed and an oxidizer (air, oxygen, or a mixture) is pumped into the space below the payload/piston.

Liquid fuel (benzene, kerosene) is injected into the space below nozzle 6 through the launch tube injectors (item 15, Fig. 4-1) and ignited. Valve 17 (Fig. 4-1) is opened. The hot combustion gas expands and pushes the payload/piston system along the launch tube together with the air column (item 7) between the piston and nozzle.

When the piston reaches the maximum gun speed (about 1 km/s), the compressed air column begins to work as a rocket engine using one of the special injection fuel programs (see Reference in [1, Ch.6<sup>12</sup>]).

As the payload/piston approaches the end of the launch tube, valve 19 is opened and the airlock (item

20) begins to operate. After the payload/piston has left the launch tube, valve 18 closes the end of the launch tube and re-directs the hot combustion gases down the bypass tube (item 21) to various turbo-machines preparing compressed air for the next shot and electricity for customers.

If a high launch frequency is required, then internal tube water injectors are used to quickly cool the launch tube.

After the payload/piston system leaves the launch tube, the payload (projectile) separates from the piston and the empty fuel tank. The payload continues to fly along a ballistic trajectory. At apogee, the payload may use a small rocket engine to reach orbit or to fly to any point on Earth.

The method by which the fuel is injected and ignited within the launch tube is critical to high-speed (hypersonic) acceleration of the payload. The author has developed the five fuel injection programs for the launch system<sup>12</sup>.

In these programs the thrust (force) is constant at all times, which means that pressure and all parameters in the rocket engine are constant. Parts of the programs have two steps. In the first step the fuel is injected into compressed air at the lower part of the tube to support a constant pressure and provide the initial acceleration of the rocket (together with air column  $L_r$ ) to the velocity  $V_o$ . In the second step the rocket engine begins to thrust and support the constant pressure and temperature in the rocket combustion chamber. The result is that the thrust force of the gas-rocket engine remains constant. In the reference article the author considered only a simplified model ([1, Fig. 6.1b]) when a rocket nozzle is absent.

## 5. Earth–Moon Cable Transport System\*

The author proposes a new transportation system for travel between Earth and the Moon. This transportation system uses mechanical energy transfer and requires only minimal energy, using an engine located on Earth. A cable directly connects a pole of the Earth through a drive station to the lunar surface. The equation for an optimal equal stress cable for the complex gravitational field of the Earth–Moon has been derived that allows significantly lower cable masses. The required strength could be provided by cables constructed of carbon nanotubes or carbon whiskers. Some of the constraints on such a system are discussed.

---

\* This review is based on paper B0.3-F3.3-0032-02 that was presented to 34<sup>th</sup> COSPAR Scientific Assembly, The World Space Congress 2002, 10–19 Oct 2002, Houston, Texas, USA. This is only part of the original manuscript (one version of the system) presented to the WSC. This part of WSC manuscript was published in as “Non-Rocket Earth–Moon Transport System”, in *Advanced Space Research*, Vol. 31, No. 11, pp. 2485–2490, 2003. See also [1, Ch.7, pp.147-155].

### Brief Description.

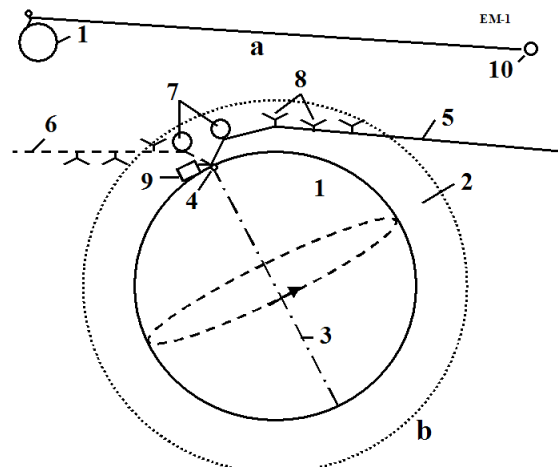
The objectives of the proposed system are to provide an inexpensive means of travel between the Earth and the Moon, to simplify space transportation technology, and to eliminate complex hardware. The proposed Earth–Moon cable transport system is shown in Fig. 5.1. The system consists of three cables: a main (central) cable, which supports the weight of the entire system, and two closed-loop transport cables, which include a set (5–10) of cable chain links connected sequentially to one other by rollers [1, Ch.7<sup>3,4</sup> (see Fig.7.3a)]. The system is connected at the Earth’s pole and to any position on the Moon’s surface that continually faces Earth. An engine located on a planet (e.g. the Earth, but it could be the Moon) drives the cable transport system. On the Earth, the cable is supported in the atmosphere by a winged device, which also counteracts the rotation of the Earth. The transfer cable

system transfers energy between load cabins moved up and down, which requires the engine moving the cable system to overcome only frictional forces.

An optimal (minimum mass, equal stress) variable diameter cable is defined for the main tether. The main cable has a relatively large but variable cross-section area (diameter) because it has to support the total system weight, which is several hundred times the load weight. In an optimal main cable the cross-section area increases (for  $K = 2$ , about 20 times) in the altitude range 0 – 150,000 km, is approximately constant in the range 150,000–380,000 km, and decreases near the Moon's surface, from 20,000 km to the surface.

The mass of the main cable is minimized because its diameter is variable along the distance (see the next section for calculation of the main cable cross-section areas and mass). The transport cables pull (move) the load cabins (one up, the other down) along the main cable. As these are moveable parts, they must have constant diameter. If they had to carry a load the full distance to the Moon, their mass would be very large. My concept separates the full distance into sub-distances (5–10), with closed-loop links for every sub-distance connected by rollers. These rollers transfer the transport cable movement from one link to another. In this case, the mass of the transport cables is minimized because at every local length (sub-distance) the cable diameter is determined by the local force. Total mass of the transport cable should be close to double the mass of the main cable.

The load containers are connected to the transport cable. When containers come up to the rollers, they pass the rollers, connect to the next link and continue their motion along the main cable. The load (cabin) has special clamps to allow this transfer between the different diameter cables in each link<sup>1</sup>. Most space payloads, like tourists, must be returned to Earth. When one container is moved up, another container is moved down. The work of lifting equals the work of descent, except for a small friction loss in the rollers. The transport system may be driven by a conventional motor located at the Earth drive station, on a space station, or on the Moon. When payloads are not being delivered into space, the system may be used to transfer mechanical energy to the Moon. For example, the Earth drive station can rotate an electric generator on the Moon.



**Fig. 5.1.** A conceptual Earth–Moon transportation system. One end is connected to the Earth's pole. the second end is connected to the Moon. Notation: 1 – the Earth; 2 – Earth's atmosphere; 3 – axis of Earth rotation; 4 – Earth Pole; 5 – Earth–Moon cable transport system in right position (one extreme of the Moon's position); 6 – Earth–Moon system in left position; 7 – air balloons; 8 – support wings; 9 – drive station; 10 – Moon.

The cable is supported in the Earth's atmosphere by air balloons (around the pole) and winged devices (far from the pole). The maximum speed of the system in the atmosphere is about 190 m/sec at the maximum distance of 2700 km in the right-hand position of Fig. 5-1. When the cable is located in the left-hand position, some wings may be out of the atmosphere and not so effective.

The Moon's orbit has eccentricity. Every 29 days the Moon's distance from Earth changes by about 50,000 km. Devices shown in Fig. 7.4 (in [1, Chapter 7]) must be used to change the length (or link length) of the transport cables as the Earth–Moon distance changes. They may be located at the Earth drive station, on a space station, in space, and/or on the Moon. The average speed of a cable length change is about 40 m/s. As the Moon pulls the transport system, it may be used to produce mechanical energy. If the cables can support 9 tons, the power can reach 1.8 million Watts. The cables rotate the electric generator and negligibly brake the Moon's movement.

## 7. Earth–Mars Cable Transport System\*

The author offers and computes a new permanent cable transport system that links a pole of the Earth with Mars orbit. This system connects Earth and Mars for 1–1.5 months every 1.7–2 years when they are located at the nearest distance and allows the transfer of people and loads to Mars and back. The system has many advantages because it uses a transport engine located on Earth, but it also requires the high strength cable made from nanotubes. This work contains theory of an optimal equal stress cable, that connects the Earth and Mars orbit, as well as computed parameters of the suggested system.

---

\*Presented as paper BO.4-C3.4-0036-02 to The World Space Congress-2002 10–19 Oct. 2002, Houston, Texas, USA. Detailed material was published in *Actual Problems of Aviation and Aerospace Systems*. No. 2 (16), vol. 8, 2003. See also [1, Ch.8, pp.157-164].

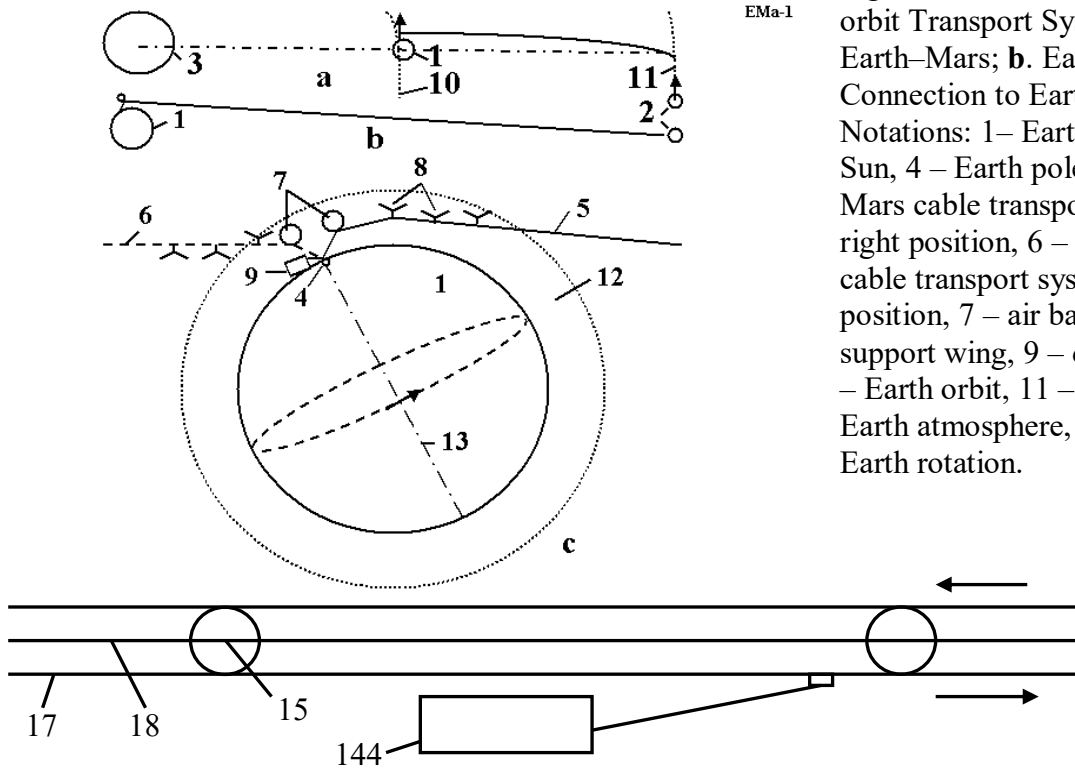
### Brief Description

The review contains the theory and results of computation for a special project. This project uses three cables (one main cable and two for driving loads) mass from artificial material: whiskers, nanotubes, with the specific tensile strength (ratio of tensile stress to density)  $k = \sigma/\gamma = 20 \cdot 10^7$  ( $K = 20$ ) or more. Nanotubes with the same or better parameters are available in scientific laboratories. The theoretical limit of nanotubes of SWNT type is about  $k = 100 \cdot 10^7$  ( $K = 100$ ).

A proposed centrifugal Mars cable transport system is shown in Figs. 6.1 and 6.2. The system includes the optimal equal stress cable which has a length approximately equal to the minimum distance of the Earth to Mars orbit. The installation has a transport system with chains connected by rollers and two transport cables.

The upper ends of the cables are located near Mars orbit and the lower ends of the cables are connected to the Earth's pole. They are supported in the Earth's atmosphere by air balloons (near the Pole) and winged devices at a maximum distance of up to 2800 km. The rotary speed of the cables changes from zero (at the pole) to 190 m/s (at the end of the maximum distance in the atmosphere). These winged devices can support cables when they are located within the lower atmosphere.

The installation would have a device that allows the length of the cables to be changed. The device would consist of a spool, motor, brake, transmission, and controller. The facility could have mechanisms for delivering people and payloads to Mars and back using the suggested transport system.



EMa-1

Fig. 6.1. The offered Earth-Mars orbit Transport System. **a.** Sun-Earth-Mars; **b.** Earth-Mars; **c.** Connection to Earth pole. Notations: 1- Earth, 2 - Mars, 3 - Sun, 4 - Earth pole, 5 - Earth-Mars cable transport system in right position, 6 - Earth-Mars cable transport system in left position, 7 - air balloon, 8 - support wing, 9 - drive station, 10 - Earth orbit, 11 - Mars orbit, 12 - Earth atmosphere, 13 - axis of Earth rotation.

Fig. 6.2. Cables of transport system. Notations: 144 - space ship, 15 - rollers, 17 - transport cable, 18 - main cable.

The delivery devices include: containers (passenger cabins, space ships, etc.), cables, motors, brakes, and controllers.

The space cabin can temporarily land on the surface of the Mars for loading and performing research. The space cabin has a small rocket engine for maneuvering and landing on the surface of Mars.

Every two years Mars comes within a minimum distance from Earth. For about 1-1.5 months the cable transport system (CTS) can be used to deliver people and loads to Mars. The space ship moves in advance to the upper end of the CTS, then when Mars arrives, the vehicles land on its surface and the people work on Mars 1-1.5 months; afterwards the space ships return to Earth. While living on Mars, the people can fly from one place to another with speeds of about 230 m/s (including Mars round trip at low altitude) in their space cabin (ship). Exploring using the CTS would not require rocket fuel.

## 7. Centrifugal Space Launcher\*

This manuscript describes a method and devices that provides a repulsive (repel, push, opposed to gravitation) force between given bodies. The basic concept is that a strong, heavy cable is projected upwards using a motorized wheel on the ground. The upward momentum of the cable is transferred to the apparatus by means of a pulley/roller mechanism, which sends the cable back down to the motor. The momentum transferred from the cable to the apparatus produces a push force which can suspend the apparatus in the air or lift it. There is an equal and opposite force on the motorized wheel on the ground. The push force can be great (up to tens of tons) and operate over long distances (up to hundreds of kilometers). This force produces great accelerations and velocities of given bodies (vehicles).

\*The main idea of this Chapter was presented as IAC-02-IAA.1.3.03, 53rd International Astronautical Congress. The World Space Congress – 2002, 10–19 Oct. 2002, Houston, Texas, USA, and the full manuscript accepted as AIAA-2005-4504, 41 Propulsion Conference, 10–12 July, 2005, Tucson, Arizona, USA. See also [1, Ch.10, pp.187-206].

### Description of Innovative Launcher

Ground sling launcher. The installation includes (see notations in Fig. 7.1): a tower, a lever (or disk), a sling (cable), conventional engines and flywheels (drive station). Optimally, the installation is located on a mountain (high altitude) to reduce air drag on the sling and apparatus and for a lower slope of initial trajectory angle. A winged space apparatus (space ship, missile, probe, projectile, etc.) is connected to the end of the sling.

The installation works in the following way (Fig. 7.1). The engine rotates the flywheels. When the flywheels accumulate sufficient energy, they rotate as a lever. The lever accelerates the space apparatus (“s.a.”). The apparatus may be located on the lever and the sling is increased after the start. The apparatus speed increases. It is greater than the lever speed in the ratio  $R/R_0$ , where  $R$  is the radius of the apparatus trajectory circle,  $R_0$  is the radius of the lever (or disk). When the apparatus reaches its chosen speed, the winged apparatus is disconnected from the sling at the desired point of the circle. While the winged apparatus is flying in the atmosphere, it can increase its slope and correct its trajectory. If the apparatus has a hypersonic (supersonic) form, the speed loss is small<sup>13</sup>.

The offered launcher is different from conventional centrifugal catapults, which have a projectile in a lever. This launcher has a long sling and the projectile is in the sling. The sling increases the lever speed many times and decreases the mass of the lever. Conventional catapults made from nanotubes have a huge mass and requires gigantic energy to work. This sling is also made from nanotubes (for space speed), but its mass is small.

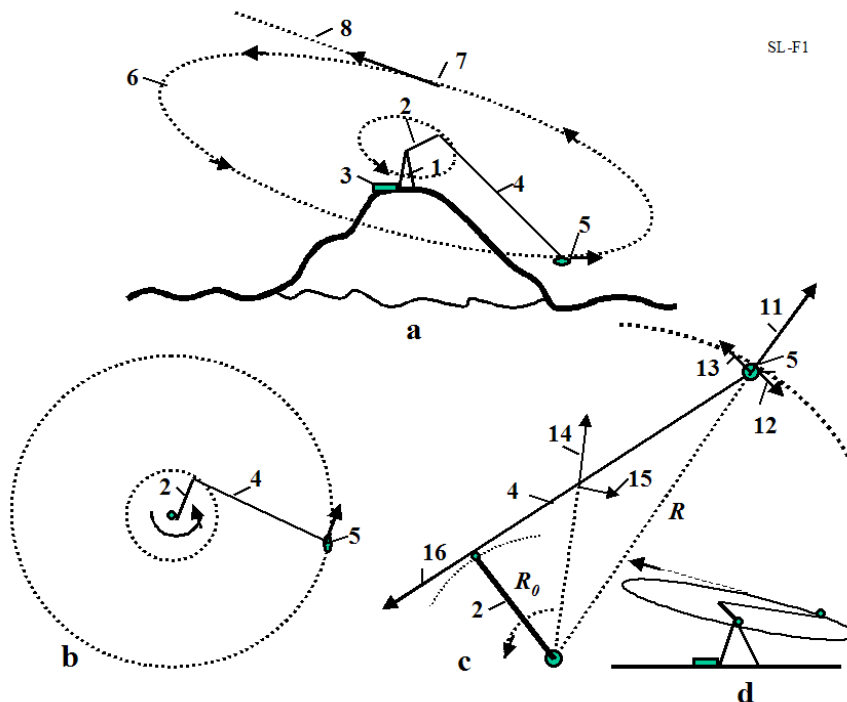


Fig. 7.1. Sling rotary launcher. a) launcher located on mountain, b) top view of installation, c) acting forces, d) side view. Notations: 1 – tower, 2 – lever or disk, 3 – engine, 4 – sling, 5 – space apparatus (s.a.), 6 –

circular launch trajectory, 7 – point of disconnection, 8 – direction of launch, 11 – centrifugal force of space apparatus, 12 – drag of s.a., 13 – speed of s.a., 14 – centrifugal force of sling, 15 – drag of sling, 16 – lever force.

If the circle is parallel to the Earth's surface, the winged apparatus disconnects from the cable, converts the linear and centrifugal acceleration into vertical acceleration (while it is flying in the atmosphere) and leaves the Earth's atmosphere.

The power station houses the engine. It can be any engine, for example, a gas turbine, or an electrical or mechanical motor. The power drive station also has an energy storage system (flywheel accumulator of energy), a transmission drive train and a clutch mechanism.

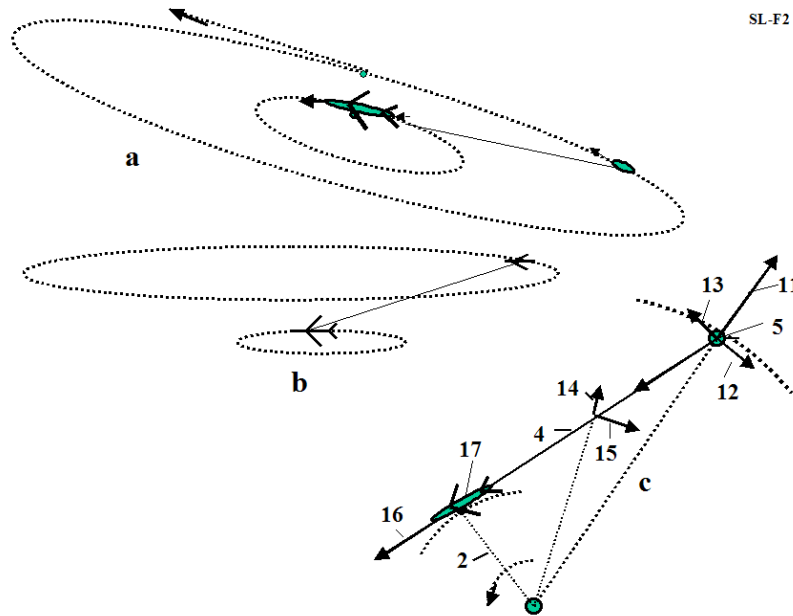


Fig. 7.2. Launching a space ship using aircraft. a) slinging slope start, b) upper start, c) installation forces.

The installation can be set on a slope, and launch a projectile at an angle to the horizon (Fig. 7.1).

The attained speed may be up to eight or more km/s (see project 2 below). If the planet does not have an atmosphere, a small installation (with a small lever) can give the projectile a very high speed, limited only by the power of the engine and the strength of the sling.

On the Earth's surface the launcher can be located under a special cover (or in a tube) in a vacuum. **Aircraft sling launcher.** Another design of this sling launcher is presented in Figs. 7.2. A small spacecraft (1 – 2 tons) is connected to a large, high-speed aircraft. The aircraft flies in a circle, increasing the sling length and accelerating the ship to high speed. The attained speed depends largely on the specific strength of the sling, the maximum aircraft speed and the thrust of the aircraft. For large existing aircraft operating in the atmosphere, the launch speed may reach up to 2 km/s. This is enough for the X-prize flight, reaching an altitude of up to 100 km and sufficient for a spaceship for tourists (see projects 3–4 below).

Advantages. The suggested launch cable system has advantages compared to the current rocket systems, as follows:

1. The sling launcher is many times less expensive than modern rocket launch systems. No expensive rockets are needed. Only motor and cable are required.



2. The sling launcher reduces the delivery cost by several thousand times (to as low as \$5 to \$10 per pound). (No rocket, cheaper fuel.)
  3. The sling launcher could be constructed within one to two years. The aircraft sling launcher requires only a cable and a spaceship. Modern rocket launch systems require many years for R&D and construction.
  4. The sling launcher does not require high technology and can be made by any non-industrial country.
  5. Rocket fuel is expensive. The ground sling launcher can use the cheapest sources of energy, such as wind, water, or nuclear power, or the cheapest fuels such as gas, coal, peat, etc., because the engine is located on the Earth's surface. Flywheels may be used as an accumulator of energy.
  6. It is not necessary to have highly qualified personnel, such as rocket specialists with high salaries.
  7. The fare for space tourists would be small.
  8. There is no pollution of the atmosphere from toxic rocket gas.
  9. Thousands of tons of useful payloads can be launched annually.
- Shortcomings of sling space launchers:
1. The need for a very strong sling (cable), made from carbon whiskers or still-to-be manufactured long nanotubes.
  2. The Earth ground sling launcher may be used only for robust loads because high centrifugal acceleration is imposed on the payload. Such payloads normally account for 70–80% of space payloads.

*Cable (sling) discussion.* The experimental and industrial fibers, whiskers, and nanotubes are considered in [1], Chapters 1–2.

The reader can find a more complete cable discussion of cable and cable characteristics in [1], Ch.10, the References<sup>3–13, 17–20</sup>.

## **8. Asteroids as Propulsion System of Space Ships\***

The purpose of this section is to draw attention to the idea of sling rotary launchers. This idea allows the building of inexpensive new space launcher systems, to launch missiles, projectiles, and space apparatus, and to use many types of energy. This chapter describes the possibilities of this method and the conditions which influence its efficiency. Included are four projects: a non-rocket sling projectile launcher, a space sling launcher, a spaceship for launching using conventional supersonic, and a space ship using subsonic aircraft. The last two only require low-cost cable made from artificial fiber, using whiskers that are produced in industry now or increasingly perfected nanotubes that are being created in a scientific laboratories.

-----  
\*The detailed work was presented as AIAA-2005-4035 at the 41 Propulsion Conference, 10–12 July, 2005, Tucson, Arizona, USA. See also [1, Ch.11, pp. 209-222].

### **Introduction.**

There are many small solid objects in the Solar System called asteroids. The vast majority are found in a swarm called the asteroid belt, located between the orbits of Mars and Jupiter at an average distance of 2.1 to 3.3 astronomical units (AU) from the Sun. Scientists know of approximately 6,000 large asteroids of a diameter of 1 kilometer or more, and of millions of small asteroids with a diameter of 3 meters or more. Ceres, Pallas, and Vesta are the three largest asteroids, with diameters of 785, 110

and 450 km (621, 378, and 336 miles), respectively. Others range all the way down to meteorite size. In 1991 the Galileo probe provided the first close-up view of the asteroid Caspra; although the Martian moons (already seen close up) may also be asteroids, captured by Mars. There are many small asteroids, meteorites, and comets outside the asteroid belt. For example, scientists know of 1,000 asteroids of diameter larger than one kilometer located near the Earth. Every day 1 ton meteorites with mass of over 8 kg fall on the Earth. The orbits of big asteroids are well known. The small asteroids (from 1 kg) may be also located and their trajectory can be determined by radio and optical devices at a distance of hundreds of kilometers.

Radar observations enable to discern of asteroids by measuring the distribution of echo power in time delay (range) and Doppler frequency. They allow a determination of the asteroid trajectory and spin and the creation of an asteroid image.

Most planets, such as Mars, Jupiter, Saturn, Uranus, and Neptune have many small moons that can be used for the proposed space transportation method.

There are also the asteroids located at the stable Lagrange points of the Earth–Moon system. These bodies orbit with the same speed as Jupiter, and might be very useful for propelling spacecraft further out into the solar system. Comets may also be useful for propulsion once a substantial spacecraft speed is obtained. It seems likely that the kinetic and rotational energy of both comets and asteroids will eventually find application in space flight.

Most asteroids consist of carbon-rich minerals, while most meteorites are composed of stony-iron.

The present idea [1]<sup>6-8</sup> is to utilize the kinetic energy of asteroids, comets, meteorites, and space debris to change the trajectory and speed of space ships (probes). Any space bodies more than 10% of a ship's mass may be used, but here mainly bodies with a diameter of 2 meters (6 feet) or larger are considered. In this case the mass (20–100 tons) of the space body (asteroid) is some 10 times more than the mass of probe (1 ton, 2000 lb) and the probe mass can be disregarded.

### Connection Method

The method includes the following main steps:

- (a) Finding an asteroid using a locator or telescope (or looking in catalog) and determining its main parameters (location, mass, speed, direction, rotation); selecting the appropriate asteroid; computing the required position of the ship with respect to the asteroid.
- (b) Correcting the ship's trajectory to obtain the required position; convergence of the ship with the asteroid.
- (c) Connecting the space apparatus (ship, station, and probe) to the space body (planet, asteroid, moon, satellite, meteorite, etc.) by a net, anchor, and a light strong rope (cable), when the ship is at the minimum distance from the asteroid.
- (d) Obtaining the necessary position for the apparatus by moving around the space body and changing the length of the connection rope.
- (e) Disconnecting the space apparatus from the space body; spooling the cable.

The equipment required to change a probe (spacecraft) trajectory includes:

- (a) A light strong cable (rope).
- (b) A device to measure the trajectory of the spacecraft with relative to the space body.
- (c) A device for spacecraft guidance and control.
- (d) A device for the connection, delivery, control, and disconnection and spooling of the rope.

### Description of Utilization

The following describes the general facilities and process for a natural space body (asteroid, comet, meteorite, or small planet) with a small gravitational force to change the trajectory and speed of a

space apparatus.

Figs. 8.1a,b,c show the preparations for using a natural body to change the trajectory of the space apparatus; for example, the natural space body 2, which is moving in the same direction as the apparatus (perpendicular to the sketch, Fig. 8.1a). The ship wants to make a maneuver (change direction or speed) in plane 3 (perpendicular to the sketch), and the position of the apparatus is corrected and moved into plane 3. It is assumed that the space body has more mass than the apparatus.

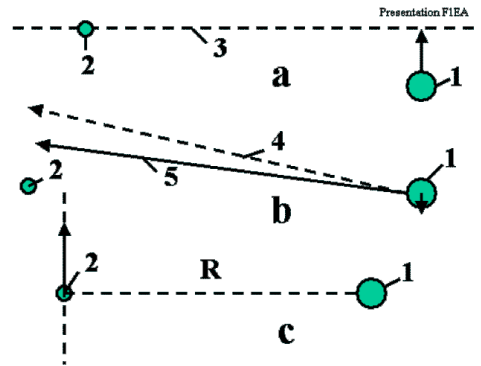


Fig. 8.1. Preparing for employment of the asteroid. Notations: 1 – space ship, 2 – asteroid, 3 – plane of maneuver. 4 – old ship direction, 5 – corrected ship direction. a) Reaching the plane of maneuver; b) Correcting the flight direction and reaching the requested radius; c) Connection to the asteroid.

When the apparatus is at the shortest distance  $R$  from the space body, it connects to the space body means of the net (Fig. 8.2a) or by the anchor (Fig. 8.2b) and rope. The apparatus rotates around the common center of gravity at the angle  $\varphi$  with angular speed  $\omega$  and linear speed  $\Delta V$ . The cardioids of additional speed and direction of the apparatus are shown in [1] Fig. 11.4 (right side). The maximum additional velocity is  $\Delta V = 2V_a$ , where  $V_a$  is the relative asteroid velocity when the coordinate center is located in the apparatus.

Fig. 8.2a shows how a net can be used to catch a small asteroid or meteorite. The net is positioned in the trajectory of the meteorite or small asteroid, supported in an open position by the inflatable ring and connected to the space apparatus by the rope. The net catches the asteroid and transfers its kinetic energy to the space apparatus. The space apparatus changes its trajectory and speed and then disconnects from the asteroid and spools the cable. If the asteroid is large, the astronaut team can use the asteroid anchor (Figs. 8.2b).

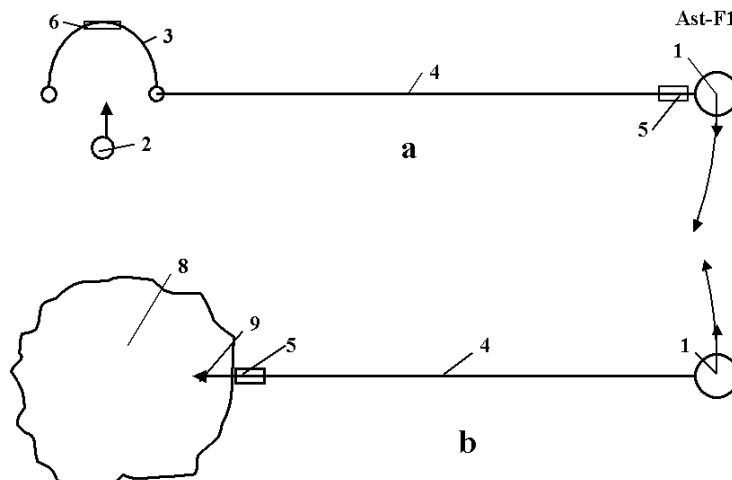


Fig. 8.2. a) Catching a small asteroid using net; b) Connection to a big asteroid using an anchor and cable. Notation: 1 – space ship, 2, 8 – asteroid, 3 – net with inflatable ring, 4 – cable (rope), 5 – load cabin, 6 – valve, 9 – anchor.

The astronauts use the launcher (a gun or a rocket engine) to fire the anchor (harpoon fork) into the asteroid. The anchor is connected to the rope and spool. The anchor is implanted into the asteroid and connects the space apparatus to the asteroid. The anchor contains the rope spool and a disconnect mechanism. The space apparatus contains a spool for the rope, motor, gear transmission, brake, and controller. The apparatus may also have a container for delivering a load to the asteroid and back (Fig. 8.2b). One possible design of the space anchor is shown in [1, Fig. 11.3]. The anchor has a body, a rope, a cumulative charge (shared charge), the rocket impulse (explosive) engine, the rope spool and the rope keeper. When the anchor strikes the asteroid surface the cumulative charge burns a deep hole in the asteroid and the rocket-impulse engine hammers the anchor body into the asteroid. The anchor body pegs the catchers into the walls of the hole and the anchor's strength keeps it attached to the asteroid. When the apparatus is to be disconnected from the asteroid, a signal is given to the disconnect mechanism.

If the asteroid is rotated with angular speed  $\omega$ , its rotational energy can be used for increasing the velocity and changing the trajectory of the space apparatus. The rotary asteroid spools the rope on its body. The length of the rope is decreased, but the apparatus speed is increased (see a momentum theory in physics).

The ship can change the length of the cable. When the radius decreases, the linear speed of the apparatus increases; conversely, when the radius increases the apparatus speed decreases. The apparatus can obtain energy from the asteroid by increasing the length of the rope.

The computations and estimations show the possibility of making this method a reality in a short period of time.

An abandoned space vehicle or large piece of space debris in Earth orbit can also be used to increase the speed of the new vehicle and to remove the abandoned vehicle or debris from orbit.

## 9. Multi-reflex Propulsion Systems for Space and Air Vehicles and Energy Transfer for Long Distance\*

The purpose of this article is to draw attention to the revolutionary idea of light multi-reflection. This idea allows the design of new engines, space and air propulsion systems, storage systems (for a beam or solar energy), transmission of energy (over millions of kilometers), creation of new weapons, etc. This method and the main innovations were offered by the author in 1983 in the former USSR. Now the author shows the immense possibilities of this idea in many fields of engineering – astronautics, aviation, energy, optics, direct conversion of light (laser beam) energy to mechanical energy (light engine), to name a few. This chapter considers the multi-reflex propulsion systems for space and air vehicles and energy transmission over long distances in space.

-----  
\* A detailed manuscript was published by A.A. Bolonkin, *JBIS*, Vol. 57, No. 11/12. 2004, pp. 379–390, 2004. See also [1, Ch.12, pp.223-244].

### Introduction

The reflection of light is the most efficient method to use for a propulsion system. It gives the maximum possible specific impulse (light speed is  $3 \cdot 10^8$  m/s). The system does not expend mass.

However, the light intensity in full reflection is very small, about  $0.6 \times 10^{-6}$  kg/ kW. In 1983 the author suggested the idea of increasing the light intensity by a multi-reflex method (multiple reflection of the light beam) and he offered some innovations to dramatically decrease the losses in mirror reflection (including a cell mirror and reflection by a super-conducting material). This allows the system to make some millions of reflections and to gain some Newtons of thrust per kW of beam power. This allows for the design of many important devices (in particular, beam engines [1, Ch.12<sup>7</sup>]) which convert light directly into mechanical energy and solve many problems in aviation, space, energy and energy transmission.

### Description of innovation

**Multi-reflex launch installation of a space vehicle.** In a multiple reflection propulsion system a set of tasks appear: how to increase a mirror's reflectivity, how to decrease the light dispersion (from mirror imperfections and non-parallel surfaces), how to decrease the beam divergence, how to inject the beam between the mirrors (while keeping the light between the mirrors for as long as possible), how to decrease the attenuation (a mirror, prism material, etc), how to increase the beam range, and how much force the system has.

To solve of these problems, the author proposes [1] Ch.12<sup>5</sup>, a special "cell mirror" which is very reflective and reflects light in the same direction from which it came, a "laser ring" which decreases the beam divergence, "light locks" which allows the light beam to enter but keep it from exiting, a "beam transfer", a "focusing prismatic thin lens", prisms, a set of lenses, mirrors located in space, on asteroids, moons, satellites, and so on.

**Cell mirrors.** To achieve the maximum reflectance, reduce light absorption, and preserve beam direction the author uses special *cell mirrors* which have millions of small 45° degree prisms (1 in Fig. 9.1a,g). Cell mirror are retroreflector cells or cube corner cells. A light ray incident on a cell is returned parallel to itself after three reflections (Fig. 9.1g). In the mirror, provided the refractive index of the prism is greater than  $\sqrt{2}$  ( $\cong 1.414$ ), the light will be reflected by total internal reflection. The small losses may be only from prism (medium) attenuation, scattering, or due to small surface imperfections and Fresnel reflections at the entrance and exit faces. Fresnel reflections do not result losses when the beam is perpendicular to the entry surface. No entry losses occur where the beam is polarized in parallel of the entry surface or the entry surface has an anti-reflection coating with reflective index  $n_1 = \sqrt{n_0 n_2}$ . Here  $n_0$ ,  $n_2$  are reflective indexes of the vacuum and prism respectively. These cell mirrors turn a beam (light) exactly back at 180° if the beam deviation is less 5–10° from a perpendicular to the mirror surface. For incident angles greater than  $\sin^{-1}(n_1/n_2)$ , no light is transmitted, an effect called total internal reflection. Here  $n$  is the refractive index of the medium and the lens ( $n \approx 1-4$ ). Total internal reflection is used for our reflector, which contains two plates (mirrors) with a set of small corner cube prisms reflecting the beam from one side (mirror) to the other side (mirror) (Fig. 9.1b,c, f). Each plate can contain millions of small (30–100 μm) prisms from highly efficient optic material used in optical cables [1] Ch.12<sup>9</sup>. For this purpose a superconductivity mirror [1] Ch.12<sup>5</sup> may also be used,

**Laser ring.** The small lasers are located in a round ring (Fig. 9.1c). A round set of lasers allows us to increase the aperture, resulting in a smaller divergence angle  $\theta$ . The entering round beam (9 in Fig. 9.1a) has slip  $\theta$  (or  $\theta/2$ ) to the vertical. The beam is reflected millions of times as is shown in Fig. 9.1b,c and creates a repulsive force  $F$ . This force may be very high, tens of N/kW (see the computation below) for motionless plates. In a vacuum it is limited only by the absorption (dB) of the prism material (see below) and beam divergence. For the mobile mirror (as for a launch vehicle) the wavelength increases and beam energy decreases as the mirrors move apart.

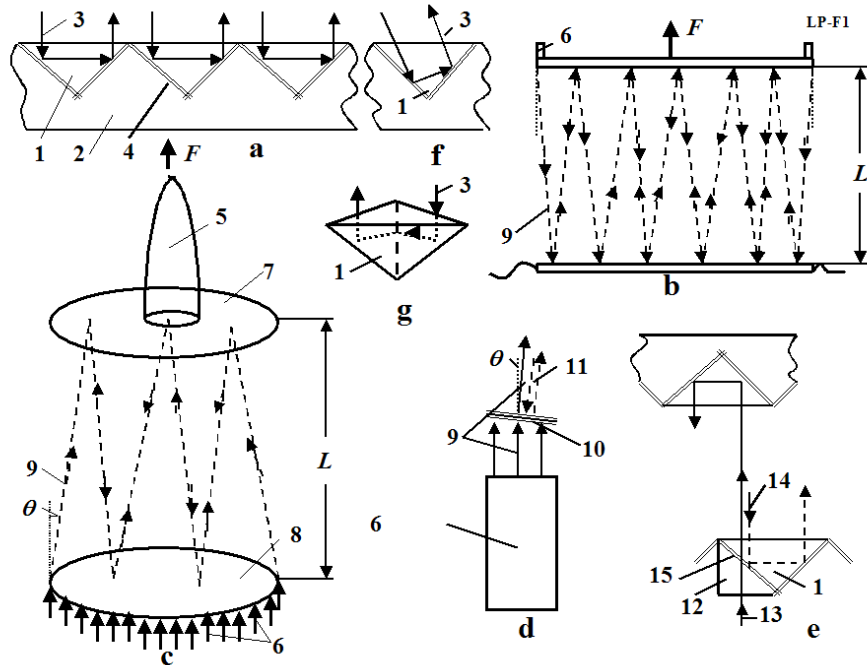


Fig. 9.1. Space launcher. Notations are: 1 – prism, 2 – mirror base, 3 – laser beam, 4 – mirror after chink (optional), 5 – space vehicle, 6 – lasers (ring set of lasers), 7 – vehicle (ship) mirror, 8 – planet mirror, 9 – laser beam, 10 – multi-layer dielectric mirror, 11 – laser beam after multi-reflection (wavelength  $\lambda_{11} > \lambda_9$ ), 12 – additional prism, 13 – entry beam, 14 – return beam, 15 – variable chink between main and additional prisms. (a) Prism (cell, corner cube) reflector. (b) Beam multi-reflection, (c) Launching by multi-reflection, (d) The first design of the light lock, (e) The second design of the light lock, (f) Reflection in the same direction when the beam is not perpendicular to mirror surface, (g) Mirror cell (retroreflector cell or cube corner cell). A light ray incident on it is returned parallel to itself after three reflections.

This system [1] Ch.12<sup>5</sup> can be applied to a space vehicle launch on a planet that has no atmosphere and small gravity (for example, the Moon; high gravity requires high beam power).

The offered multi-reflex light launcher, space and air focused energy transfer system is very simple (needing only special mirrors, lenses and prisms), and it has a high efficiency. One can directly transfer the light beam into space acceleration and mechanical energy. A distant propulsion system can obtain its energy from the Earth. However, we need very powerful lasers. Sooner or later the industry will create these powerful lasers (and cell mirrors) and the ideas presented here will become possible. The research on these problems should be started now.

Multi-reflex engines<sup>7</sup> may be used in aviation as the energy can be transferred from the power stations on the ground to the aircraft using laser beams. The aircraft would no longer carry fuel and the engine would be lighter in weight so its load capability would double. The industry produces a one Megawatt (1000 kW) laser now. This is the right size for mid-weight aircraft (10–12 tons).

The linear light engine does not have a limit to its speed and may be used to launch space equipment and space ships in non-rockets method described in [1] Ch.12<sup>10–29</sup>. This method is certain also to have many military applications.

## 10. Electrostatic Solar wind propulsion\*

A revolutionary method for space flights in outer space is suggested by the author. Research is present to show that an open high charged (100 MV/m) ball of small diameter (4–10 m) made from thin film collects solar wind (protons) from a large area (hundreds of square kilometers). The proposed propulsion system creates many Newtons of thrust, and accelerates a 100 kg space probe up to 60–100 km/s for 100–800 days. The 100 kg space apparatus offers flights into Mars orbit of about 70 days, to Jupiter about 150 days, to Saturn about 250 days, to Uranus about 450 days, to Neptune about 650 days, and to Pluto about 850 days.

The author has computed the amount thrust (drag), to mass of the charged ball, and the energy needed for initial charging of the ball and discusses the ball discharging in the space environment. He also reviews apparent errors found in other articles on these topics. Computations are made for space probes with a useful mass of 100 kg.

-----  
 \*The work was presented as AIAA-2005-3857 at the 41st Propulsion Conference, 10–13 July 2005, Tucson, Arizona, USA. See also [1, Ch.13, pp.245-270].

### Introduction.

**Brief information about solar Wind.** The Sun emits plasma which is a continuous outward flow (solar Wind) of ionized solar gas throughout our solar system. The solar wind contains about 90% protons and electrons and some quantities of ionized  $\alpha$ -particles and gases. It attains speeds in the range of 300–750 km/s and has a flow density of  $5 \times 10^7 - 5 \times 10^8$  protons/ electrons/cm<sup>2</sup>s. The observed speed rises systematically from low values a 300–400 km/s to high values of 650–700 km/s in 1 or 2 days and then returns to low values during the next 3 to 5 days ([1], Fig. 13.1). Each of these high-speed streams tends to appear at approximately 27-day intervals or to recur with the rotation period of the Sun. On days of high Sun activity the solar wind speed reaches 1000 (and more) km/s and its flow density  $10^9 - 10^{10}$  protons/electrons/ cm<sup>2</sup>s, 8–70 particles in cm<sup>3</sup>. The Sun has high activity periods some days each year.

The pressure of the solar wind is very small. For full braking it is in the interval  $2.5 \times 10^{-10} \div 6.3 \times 10^{-9}$  N/m<sup>2</sup>. This value is double when the particles have full reflection. The interstellar medium also has high energy particles. Their density is about 1 particle/cm<sup>3</sup>.

### Brief description of the propulsion system.

**Space propulsion system.** The suggested propulsion system is very simple. It includes a hollow ball made up of a thin, strong, film – covered conductive layer or a ball of thin net. The ball is charged by high voltage static electricity which creates a powerful electrostatic field around it. Charged particles of solar wind of like charges repel and particles with the unlike charges attract. A small proportion of them run through the ball, a larger proportion flow round the ball in hyperbolic trajectory into the opposite direction, and another proportion are deviates from their initial direction in hyperbolic curves. As a result the charged ball has drag when the ball speed is different from solar speed (Fig.10.1). The drag also occurs when the particles and the ball have the same electrical charge. In this case the particles are repelled from the charged ball (Fig. 10.1) and brake it. This solar wind drag provides thrust in our proposed propulsion system. The pressure of solar wind is very small, but the offered system (a charged ball of radius 6–10 m) collects particles (protons or electrons) from a large area (an area of tens of kilometers radius for protons and hundreds of kilometers for electrons), creates a thrust of some Newtons and a 100-kg space ship reaches speeds of tens of km/s in 50–300 days (see



theory and computation below and References [1] Ch.13<sup>29, 42-47</sup>).

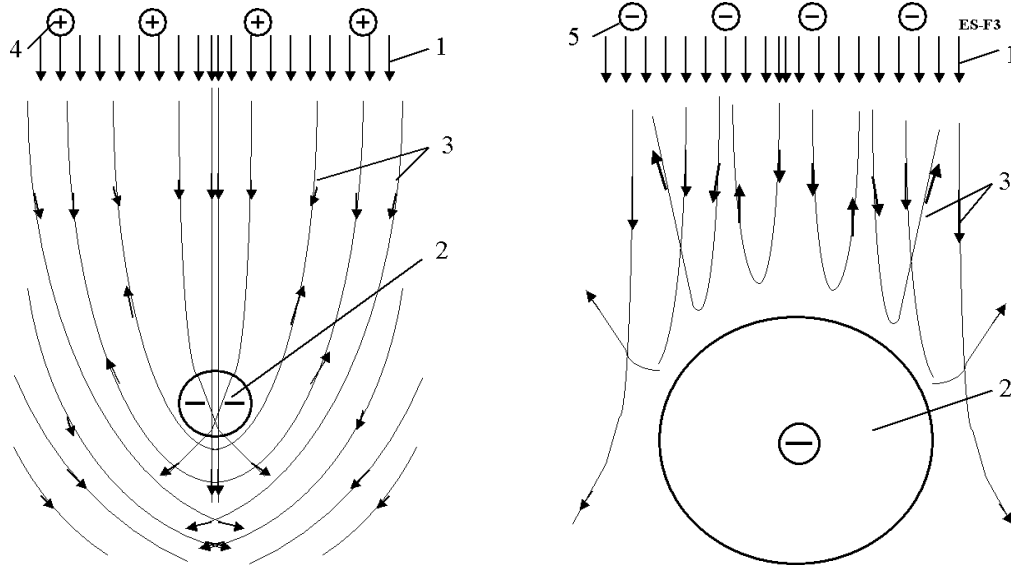


Fig. 10.1 (Left) Hyperbolic trajectory of protons around static negative charge (or electrons around positive charge) (unlike charges). Notations are: 1 – solar wind (charged particles); 2 – hollow negatively charged ball of thin film; 3 – hyperbolic trajectory of charged particles; 4 – positively charged particles (protons).

(Right). Trajectory of particles having the same charge as the ball. Notations are: 5 – negatively charged particles.

The proposed new propulsion mechanism differs from previous concepts in very important respects; including the coupling to the protons of the solar wind using an open single-charge ball. The opposite charge is expelled into infinite space. This innovation increases the area of influence by up to hundreds of kilometers for protons and allows the acquisition of significant vehicle thrust. This thrust is enough to accelerate a heavy space craft to very high speed and permits very short flight times to far planets.

The offered revolutionary propulsion system has a simple design, which can give useful acceleration to various types of spacecraft. The offered propulsion system creates many Newtons of thrust, and can accelerate a 100 kg space probe up to 60–100 km/sec in 100–800 days.

In the offered wind propulsion system the particles run away from the ball, brake and return in infinity for initial speed. These premises must be examined using more complex theories to account for the full intersection between the suggested installation and solar wind (including thermonuclear reactions). This would be a revolutionary breakthrough in interplanetary space exploration.

The author has developed the initial theory and the initial computations to show the possibility of the offered concept. He calls on scientists, engineers, space organizations, and companies to research and develop the offered perspective concepts.

## 11. Electrostatic Utilization of Asteroids for Space Flight\*

The author offers an electrostatic method for changing the trajectory of space probes. The method uses electrostatic force and the kinetic or rotary energy of asteroids, comet nuclei, meteorites or other space bodies (small planets, natural planet satellites such a moons, space debris, etc.) to increase or decrease ship/ probe speed by 1000 m/s or more and to achieve any new direction in outer space. The flight possibilities of spaceships and probes are thereby increased by a factor of millions.

-----  
 \*The full text was presented by the author as Paper AIAA-2005-4032 at the 41 Propulsion Conference, 10–12 July 2005, Tucson, Arizona, USA; or [1, Ch.14, pp.271-280].

## Description

. The method includes the following main steps (Fig. 11.1):

- (a) Finding an asteroids using a locator or telescope (or looking in a catalog) an asteroid and determining its main parameters (location, mass, speed, direction, rotation); selecting the appropriate asteroid; computing the required position of the ship with respect to the asteroid.
- (b) Correcting the ship's trajectory to obtain the required position; convergence of the ship with the asteroid.
- (c) Charging the asteroid and space apparatus ball using a charge gun.
- (d) Obtaining the necessary apparatus position and speed for the apparatus by flying it around the space body and changing the charge of the apparatus and space body (asteroids).
- (e) Discharging the space apparatus and the space body.

The equipment requires for changing a probe (spacecraft) trajectory includes:

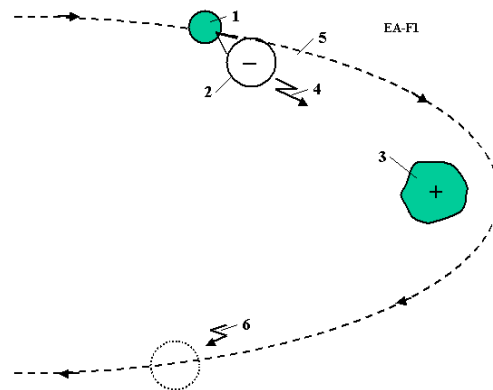


Fig. 11.1. Method of electrostatic maneuvers of the space apparatus. Notations: 1 – space apparatus, 2 – charged ball, 3 – asteroid, 4 – charged gun, 5 – new apparatus trajectory, 6 – discharging the apparatus and asteroid.

- (a) A charging gun.
- (b) Devices for finding and measuring the asteroids (space bodies), and computing the trajectory of the spacecraft relative of the space body.
- (c) Devices for spacecraft guidance and control.
- (d) A device for discharging of the apparatus and asteroids (space body) (see [1] Fig. 14.1).

## 12. Electrostatic Levitation on the Earth and Artificial Gravity for Space Ships and Asteroids\*

The author offers and researches the conditions which allow people and vehicles to levitate on the Earth using the electrostatic repulsive force. He shows that by using small electrically charged balls, people and cars can take flight in the atmosphere. Also, a levitated train can attain high speeds. He has computed some projects and discusses the problems which can appear in the practical development of this method. It is also shown how this method may be used for creating artificial gravity (attraction force) into and out of space ships, space hotels, asteroids, and small planets which have little gravity.

-----  
 \*Presented as paper AIAA-2005-4465 at 41 Propulsion Conference, 10–13 July 2005, Tucson, Arizona, USA; or [1, Ch. 15, pp. 281-302].

### Brief description of innovation

It is known that like electric charges repel, and unlike electric charges attract (Fig. 12.1a,b,c). A large electric charge (for example, positive) located at altitude induces the opposite (negative) electric charge at the Earth's surface (Figs. 12.1d,e,f,g) because the Earth is an electrical conductor. Between the upper and lower charges there is an electric field. If a small negative electric charge is placed in this electric field, this charge will be repelled from the like charges (on the Earth's surface) and attracted to the upper charge (Fig. 12.1d). That is the electrostatic lift force. The majority of the lift force is determined by the Earth's charges because the small charges are conventionally located near the Earth's surface. As shown below, these small charges can be connected to a man or a car and have enough force to lift and supports them in the air.

The upper charge may be located on a column as shown in Fig. 12.1d,e,f,g or a tethered air balloon (if we want to create levitation in a small town) (Fig. 12.1e), or air tube (if we want to build a big highway), or a tube suspended on columns (Fig. 12.1f,g). In particular, the charges may be at two identically charged plates, used for a non-contact train.

A lifting charge may use charged balls. If a thin film ball with maximum electrical intensity of below  $3 \times 10^6$  V/m is used, the ball will have a radius of about 1 m (the man mass is 100 kg). For a 1 ton car, the ball will have a radius of about 3 m (see the computation in [1] and Fig. 15.2g,h,i). If a higher electric intensity is used, the balls can be small and located underneath clothes.

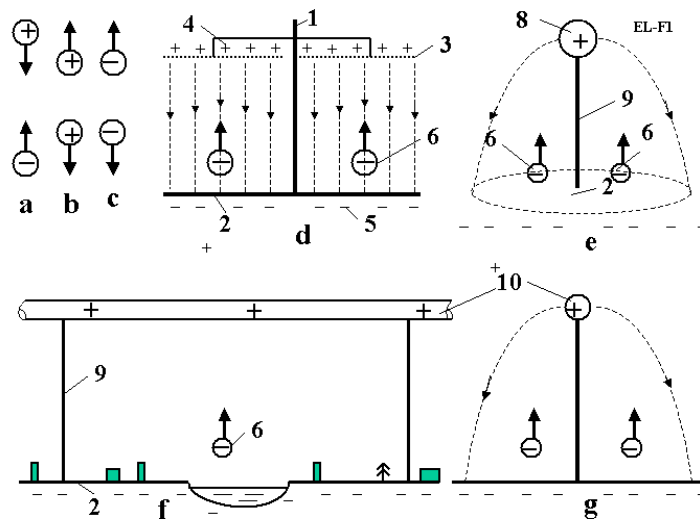


Fig. 12.1. Explanation of electrostatic levitation: a) Attraction of unlike charges; b,c) repulsion of like charges; d) Creation of the homogeneous electric field (highway); e) Electrical field from a large spherical charge ;

f,g) Electrical field from a tube (highway) (side and front views). Notations are: 1, 9 – column, 2 – Earth (or other) surface charged by induction, 3 – net, 4 – upper charges, 5 – lower charges, 6 – levitation apparatus, 8 – charged air balloon, 9 – column, 10 – charged tube.

### 13. Guided Solar Sail and Energy Generator\*

A solar sail is a large thin film mirror that uses solar energy for propulsion. The author proposed innovations and a new design of Solar sail in 1985 [1] Ch.16<sup>1</sup>. This innovation allows (main advantages only):

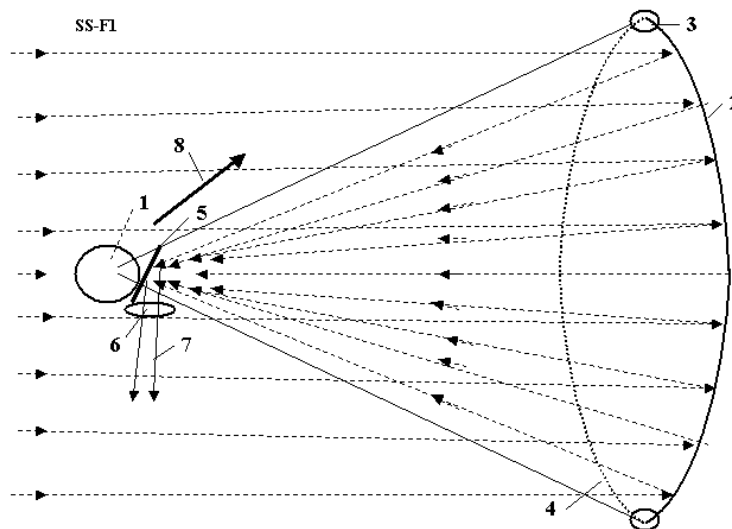
- 1) An easily controlled amount and direction of thrust without turning a gigantic sail;
- 2) Utilization of the solar sail as a power generator (for example, electricity generator);
- 3) Use of the solar sail for long-distance communication systems.

-----  
 \* The detail manuscript was presented as AIAA-2005-3857 on the 41<sup>st</sup> Propulsion Conference, 10–12 July 2005, Tucson, Arizona, USA; or see [1, Ch.16, pp. 303-308].

#### Description of innovation and their advantages

The proposed innovation of a solar sail<sup>1</sup> is presented in Fig. 13.1. Theory developed in author publication [1, Ch.16<sup>2</sup>] may be useful for flight analysis. The solar sail contains: a space ship, 1, a spherical reflector, 2, a mirror, 5, and additional devices to support spherical reflector, control the thrust direction, and convert the light energy into electricity and additional thrust.

energy in the proposed sail and can increase the thrust over time.



**Fig. 13.1.** Proposed guided solar sail and electricity generator. Notations are: 1 – space ship; 2 – thin film reflector; 3 – inflatable (or electrically charged) toroid which support the reflector in an open (unfolded) position; 4 – transparent thin film or light charged net which support the spherical form of the reflector; 5 – control mirror, which guides thrust direction; 6 – lens or trap for communication; 7 – reflected beam (located at the center of the ship's mass). 8 – direction of thrust.

The suggested propulsion system works in the following way. The reflector, 2, focuses the sunlight into the control ship mirror, 5, located at the spaceship's center of mass. We are able to change the position of this mirror, send the focused beam in the right direction and achieve the necessary thrust direction without turning the space sail because the space sail is large, turning it is very complex problem, but this problem is avoided in the suggested design.

If we direct the solar beam into the ship, we can convert the huge solar energy into any other sort of energy, for example, into electricity using a conventional method (solar cell or heat machine). A reflector of  $100 \times 100 \text{ m}^2$  produces 14,000 kW energy at 1 AU. The developed ion thrusters are very efficient and have a high specific impulse, but they need a great amount of energy. We have this

The offered system can be also used for long distance communication by sending a focused beam is to the Earth and transmitting the necessary information.

The author has also proposed a method using surface tension of a solar sail and a solar mirror [1, Ch.16<sup>10</sup>].

The suggested revolutionary propulsion system uses current technology and may be produced in the near future but needs detailed research and computation.

## 14. Radioisotope Space Sail and Electro-Generator\*

Radioisotope sail is a thin film of an alpha particle emitting radioisotope deposited on the back of a plastic sail that can provide useful quantities of both propulsion and electrical power to a deep space vehicle. The momentum kick of the emitted alpha particles provides radioisotope sail thrust levels per square meter comparable to that of a solar sail at one astronomical unit (1 AU). The electrical power generated per 1 square m is comparable to that obtained from solar cells at 1 AU. Radioisotope sail systems will maintain these propulsion and power levels at distances from the Sun where solar powered systems are ineffective.

The propulsion and power levels available from this simple and reliable high-energy-density system would be useful for supplying propulsion and electrical power to a robotic deep space mission to the Oort Cloud or beyond, or to a robotic interstellar flyby or rendezvous probe after its arrival at the target star.

---

\* Detailed work was presented by the author as AIAA-2005-4225 at the 41st Propulsion Conference, 10–12 July, 2005, Tucson, Arizona, USA; or see [1, Ch.17, pp.309-316].

## Description of method and innovations

### Brief history of innovation

The idea of using a radioisotope recoil propulsion as it is shown in Fig.14.1a is very old [1, Ch.17<sup>15</sup>]. The author has proposed many innovations in method is using radioisotope space sail and electric generators in patent applications [1, Ch.17<sup>1-13</sup>] in 1983 and in paper IAF 92-0573 presented to the World Space Congress in 1992 [1, Ch.17<sup>14</sup>]. The work [1, Ch.17<sup>16</sup>] written in 1995 summarized the knowledge for the conventional case in Fig. 14.1a. Bolonkin innovations decrease the weight of traditional radioisotope sail (RadSail, RS, IsoSail) by 2–4 times; increase the thrust by 2–3 times, and the electric power by 2 times and allows control of thrust and thrust direction without needing to turn the large RadSail.

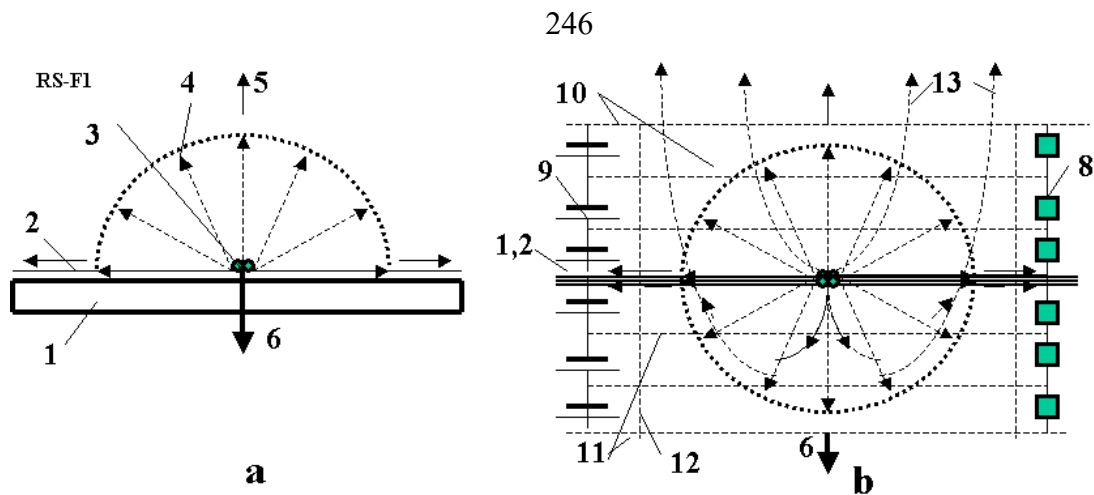


Fig. 14.1. a) Conventional radioisotope sail; b) suggested (innovated) radioisotope sail. Notations are: 1 – substrate (base of sail), 2 – isotope layer, 3 – isotope atom, 4 – alpha particles, 5 – direction of 1/6 particle flow, 6 – thrust, 8 – electric loading, 9 – initial charging, 10, 11, 12 – condenser nets, 13 – particle trajectory.

Offered innovation allows us to reach a probe speed of more than 2000 km/s, so the design may be used for interstellar probes.

This method allows nuclear waste and unnecessary nuclear bombs to be used for producing the radioisotope material.

The offered method is realistic at the present time, has a high possibility to being successful, and is much cheaper for deep missions than other currently proposed method.

## 15. Electrostatic Solar Sail\*

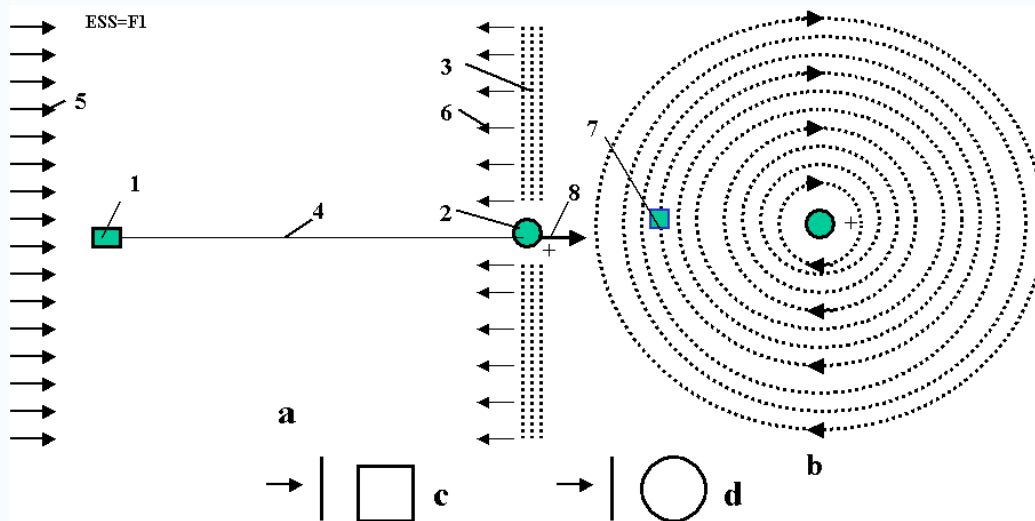
The solar sail has become well-known after much discussion in the scientific literature as a thin continuous plastic film, covered by sunlight-reflecting appliquéd aluminum. Earlier, there were attempts to launch and operate solar sails in near-Earth space and there are experimental projects planned for long powered space voyages. However, as currently envisioned, the solar sail has essential disadvantages. Solar light pressure in space is very low and consequently the solar sail has to be very large in area. Also it is difficult to unfold and unfurl the solar sail in space. In addition it is necessary to have a rigid framework to support the thin material. Such frameworks usually have great mass and, therefore, the spacecraft's acceleration is small.

Here, the author proposes to discard standard solar sail technology (continuous plastic aluminum-coated film) with the intention instead of using millions of small, very thin aluminum charged plates and to release these plates from a spacecraft, instigated by an electrostatic field. Using this new technology, the solar sail composed of millions of plates can be made gigantic area but have very low mass. The acceleration of this new kind of solar sail may be as much as 300 times that achieves by an ordinary solar sail. The electrostatic solar sail can even reach a speed of about 300 km/s (in a special maneuver up to 600–800 km/sec). The electrostatic solar sail may be used to move a large spaceship or to act as an artificial Moon illuminating a huge region of the Earth's surface.

\*See [1, Ch.18, pp. 317-326].

## Brief description of the innovations

A conventional solar sail is a dielectric thin film (thickness 5  $\mu\text{m} = 5000 \text{ nm}$ ) with an aluminum layer 100 nm thick, and it has 90% reflectivity. The weight of one square meter is 5–7  $\text{g}/\text{m}^2$ . If it accelerates by itself the maximum acceleration is about 1  $\text{mm}/\text{s}^2$ . However, the gigantic thin film needs a rigid structure to support the very thin film in an unfolded position and to enable it to be controlled. This rigid structure has a large weight, so it is very difficult to launch and to unfurl the structure in space. All attempts to do this (for example, to unfurl the inflatable radio-antennas in space) have failed.



**Fig. 15.1.** The proposed electrostatic solar sail. **a.** Side view; **b.** Front view; **c.** Side and front views of square petal; **d.** Side and front views of round petal. Notation: 1 – spaceship, 2 – charged ball, 3 – charged plate-petals, 4 – cable connecting the ship and the ball, 5 – solar rays, 6 – reflected rays, 7 – charged petals, 8 – thrust (drag).

The author proposes to use small thin charged aluminum plates (petals) supported by a central electrostatic ball and rotated around the ball (Fig. 15.1). They rotate also around their own axis and mainly in a direction perpendicular to the solar rays. The diameter of the plate-petals is small, about 1 mm or less, and it is not a necessity to use the dielectric film. The aluminum film may be very thin because the individual petal size is small.

## 16. Recombination Space Jet Propulsion Engine\*

There are four known ionized layers in the Earth's atmosphere, located at an altitude of 85–400 km. Here the concentration of ions reaches millions of particles in 1 cubic centimeter. In the inter-planetary medium the concentration of ion reaches  $10\text{--}10^3$  particles in  $1 \text{ cm}^3$  and in interstellar space it is about  $1\text{--}10$  in  $1 \text{ cm}^3$ . As a result there is interaction between solar radiation in the Earth's atmosphere, solar wind, and galactic radiation.

About 90% these particles are protons and electrons. The particle density is low and they can exist for a long time before they come into collision with each other. However, if we increase the density of the particles in an engine, they collide with one another, recombine, warm up, leave the propulsion system with high speed, and create thrust.



The energy of recombination is significantly more than the heat capability of conventional fuel and the specific impulse of the propulsion system is high.

The author proposes collecting and concentrating charged particles from a large area using a magnetic field. Space ships, space apparatus, and satellites would then not need fuel and could be accelerated or fly to infinity. This may be a revolution in aerospace.

=====

\*See [1, Ch. 19, pp. 327-338].

### Description of innovation

In the recombination propulsion engine contains a tube with an intake and a nozzle, and a solenoid (Fig. 16.1).

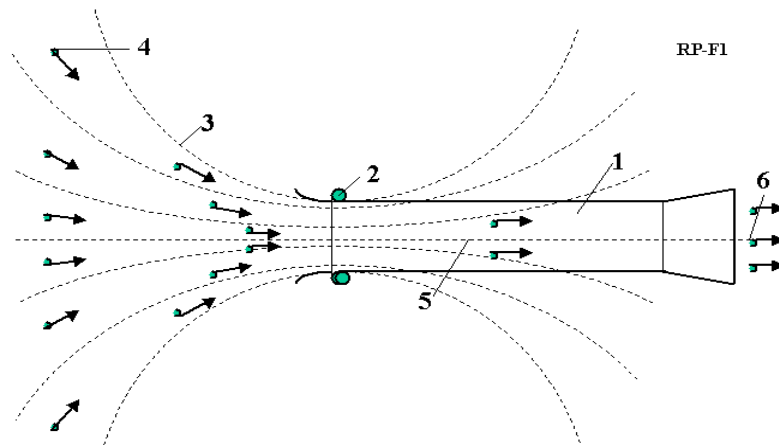


Fig. 16.1. Recombination space jet propulsion engine (actuator of magnetic field). Notations are: 1 – engine, 2 – solenoid, 3 – magnetic lines, 4 – charged particles, 5 – recombination zone, 6 – exit.

The solenoid may be conventional or superconductive. It produces a powerful magnetic field, which collects charged particles. If the density of the charged particles is sufficient (the distance the particles travel is less than the tube length) the particles came into contact with each other and recombine.

This minimum energy is more than the energy of the most efficient chemical reaction,  $H_2 + O = H_2O$ , by hundreds of times. This means the specific impulse of the recombination engine will be very high. The heating of engine walls will be small, however, because the density of the particle gas is low. Using this proposed method, we do not need to expend fuel and can achieve a large acceleration of a space vehicle, or support the satellite at altitude for an infinite amount of time.

Idea's are needed in research and development of this method.

## 17. Electronic Sail\*

A solar sail reflects solar light and can be a used as propulsion system, as described in [1, Ch. 16]. It needs thin film of a very large area. This manuscript proposes a new way of creating a reflecting surface of large area using an electronic method. This method needs research and development but it may be easier and more efficient than the film method.

-----

\*See [1, Ch.19, pp.334-335].

### Brief description of innovation

The proposed electronic sail has a positive charge, 1 (see Fig. 17.1). The free electrons, 2, are injected into space around the positive charge so they rotate around the center of the charge and form a thin disk in a plane perpendicular to the direction of the Sun light. If the concentration of electrons is sufficient, they will reflect the solar light like a mirror and produce thrust.

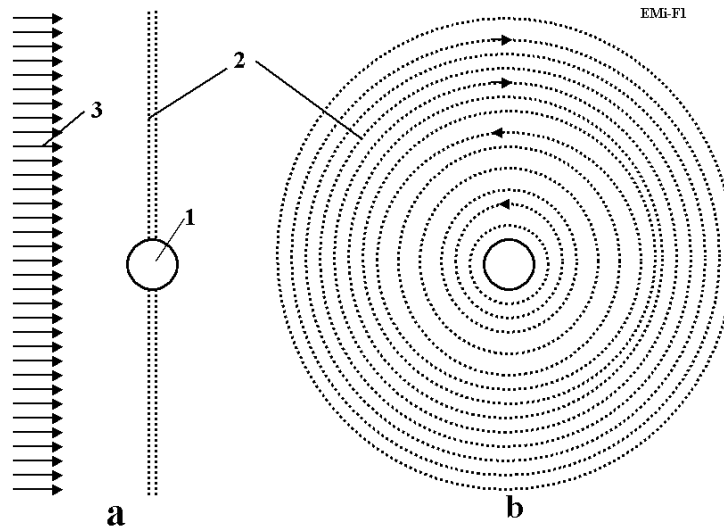


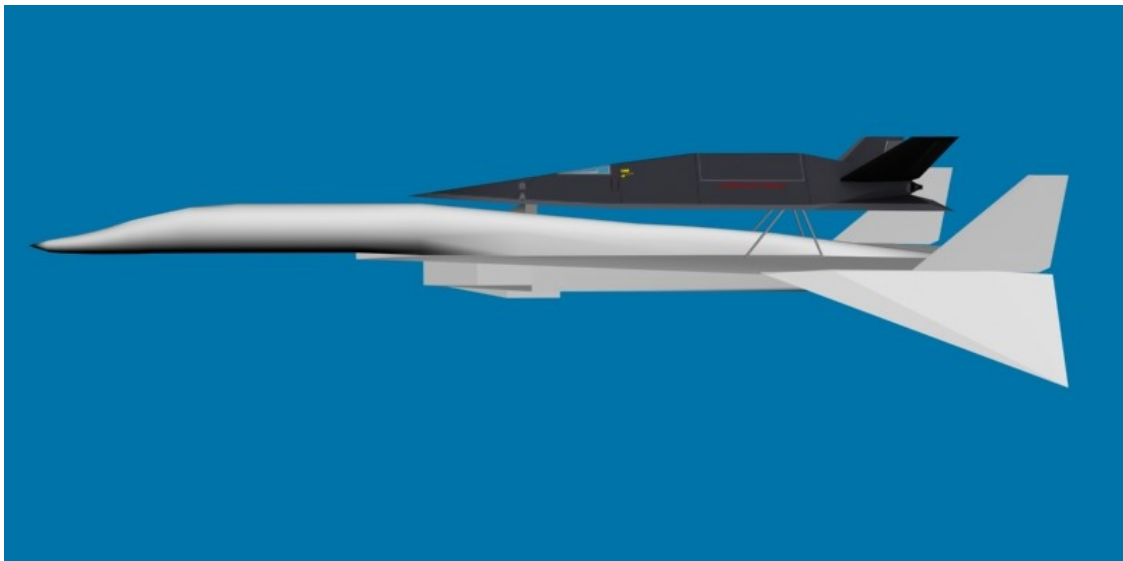
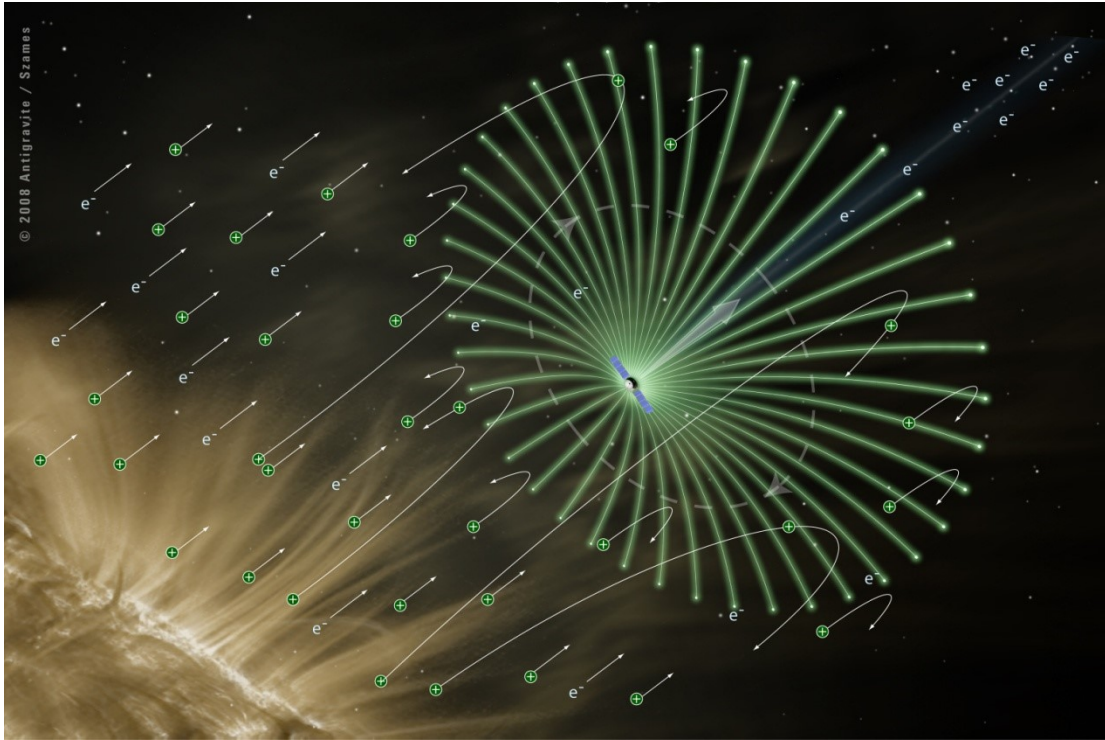
Fig. 17.1. Electronic solar sail. **a** – side view, **b** – front view. Notations are: 1 – positive charge, 2 – electronic disk, 3 – solar light.

This electronic sail may be an electrostatic solar wind sail, as described in [1] Chapter 13, if the central charge is positive. The solar wind electrons became concentrated around it and the mass of electrons reflects the solar light. Thrust from the solar wind is small because the electron mass is about 2000 times less than the proton mass, but the solar light pressure is thousands of times greater than solar wind (protons) pressure. The offered installation may also be used as a space mirror to illuminate the Earth's surface. This idea needs further research.

### References

- Many works noted below the reader can find on site Cornell University <<http://arxiv.org/>>, sites <<http://www.scribd.com>>, <http://www.archive.org>, <<http://bolonkin.narod.ru/p65.htm>> and in Conferences 2002-2006 (see, for example, Conferences AIAA, <<http://aiaa.org/>>, search "Bolonkin")
1. Bolonkin A.A., (2005) "Non-Rocket Space Launch and Flight", Elsevier, 2005, <http://www.archive.org/details/Non-rocketSpaceLaunchAndFlight>, <http://www.scribd.com/doc/24056182>
  2. K.E. Tsiolkovski: "Speculations About Earth and Sky on Vesta", Moscow, Izd-vo AN SSSR, 1959; Grezi o zemle i nebe (in Russian), Academy of Sciences, USSR., Moscow, p. 35, 1999.
  3. Geoffrey A. Landis, Craig Cafarelli, The Tsiolkovski Tower Re-Examined, *JBIS*, Vol. 32, p. 176–180, 1999.
  4. Y. Artsutanov. Space Elevator, [http://www.liftport.com/files/Artsutanov\\_Pravda\\_SE.pdf](http://www.liftport.com/files/Artsutanov_Pravda_SE.pdf).
  5. A.C. Clarke: *Fountains of Paradise*, Harcourt Brace Jovanovich, New York, 1978.
  6. Bolonkin A.A. (2006), Book "New Concepts, Ideas and Innovation in Aerospace", NOVA, 2008. <http://www.scribd.com/doc/24057071>. <http://www.archive.org/details/NewConceptsIfeasAndInnovationsInAerospaceTechnologyAndHumanSciences>
  7. Bolonkin A.A. (2007), "Macro-Engineering: Environment and Technology", NOVA, 2008. <http://Bolonkin.narod.ru/p65.htm>, <http://www.scribd.com/doc/24057930>. <http://www.archive.org/details/Macro-projectsEnvironmentsAndTechnologies>

8. Bolonkin A.A. (2008), "New Technologies and Revolutionary Projects", Scribd, 2008, 324 pgs, <http://www.scribd.com/doc/32744477> ,  
<http://www.archive.org/details/NewTechnologiesAndRevolutionaryProjects>
9. Bolonkin A.A., Book "Non-Rocket Space Launch and Flight", Elsevier. 2006, Ch. 9 "*Kinetic Anti-Gravotator*", pp. 165-186; <http://Bolonkin.narod.ru/p65.htm>, <http://www.scribd.com/doc/24056182> ; Main idea of this Chapter was presented as papers COSPAR-02, C1.1-0035-02 and IAC-02-IAA.1.3.03, 53<sup>rd</sup> International Astronautical Congress. The World Space Congress-2002, 10-19 October 2002, Houston, TX, USA, and the full manuscript was accepted as AIAA-2005-4504, 41<sup>st</sup> Propulsion Conference, 10-12 July 2005, Tucson, AZ, USA.<http://aiaa.org> search "Bolonkin".
10. Bolonkin A.A., Book "Non-Rocket Space Launch and Flight", Elsevier. 2006, Ch.5 "*Kinetic Space Towers*", pp. 107-124, Springer, 2006. <http://Bolonkin.narod.ru/p65.htm> or <http://www.scribd.com/doc/24056182> .  
<http://www.archive.org/details/Non-rocketSpaceLaunchAndFlight>
11. Bolonkin A.A., "*Transport System for Delivery Tourists at Altitude 140 km*", manuscript was presented as paper IAC-02-IAA.1.3.03 at the World Space Congress-2002, 10-19 October, Houston, TX, USA.  
<http://Bolonkin.narod.ru/p65.htm> ,
12. Bolonkin A.A. (2003), "*Centrifugal Keeper for Space Station and Satellites*", JBIS, Vol.56, No. 9/10, 2003, pp. 314-327. <http://Bolonkin.narod.ru/p65.htm> . See also [11] Ch.3.
13. Bolonkin A.A., Book "Non-Rocket Space Launch and Flight", by A.Bolonkin, Elsevier. 2006, Ch.3 "*Circle Launcher and Space Keeper*", pp.59-82. <http://www.scribd.com/doc/24056182> ,  
<http://www.archive.org/details/Non-rocketSpaceLaunchAndFlight>
14. Bolonkin A.A., Book "New Concepts, Ideas and Innovation in Aerospace", NOVA, 2008, Ch. 3 "*Electrostatic AB-Ramjet Space Propulsion*", pp.33-66. <http://www.scribd.com/doc/24057071>.  
<http://www.archive.org/details/NewConceptsIfeasAndInnovationsInAerospaceTechnologyAndHumanSciences>
- 15 Bolonkin A.A., Book "New Concepts, Ideas and Innovation in Aerospace", NOVA, 2008, Ch.12, pp.205-220, "*AB Levitrons and Their Applications to Earth's Motionless Satellites*".  
<http://www.scribd.com/doc/24057071> ,  
<http://www.archive.org/details/NewConceptsIfeasAndInnovationsInAerospaceTechnologyAndHumanSciences>
16. Bolonkin A.A., Book "Macro-Projects: Environment and Technology", NOVA, 2008, Ch.10, pp.199-226, "*AB-Space Propulsion*", <http://www.scribd.com/doc/24057930> ,  
<http://Bolonkin.narod.ru/p65.htm> .  
<http://www.archive.org/details/Macro-projectsEnvironmentsAndTechnologies>
17. Bolonkin A.A., Magnetic Suspended AB-Structures and Moveless Space Satellites.  
<http://www.scribd.com/doc/25883886> .
18. Bolonkin A.A., Femtotechnology: Design of the Strongest AB-Matter for Aerospace.  
<http://www.archive.org/details/FemtotechnologyDesignOfTheStrongestAb-matterForAerospace>.
19. Bolonkin A.A., Converting of any Matter to Nuclear Energy by AB-Generator and Aerospace .  
<http://www.archive.org/details/ConvertingOfAnyMatterToNuclearEnergyByAb-generatorAndAerospace>.
20. Bolonkin A.A., LIFE. SCIENCE. FUTURE (Biography notes, researches and innovations). Scribd, 2010, 208 pgs. 16 Mb. <http://www.scribd.com/doc/48229884>,  
<http://www.archive.org/details/Life.Science.Future.biographyNotesResearchesAndInnovations>
21. Krinker M., Magnetic-Space-Launcher. <http://www.scribd.com/doc/24051286/>
22. Krinker M., Review of Space Towers. <http://www.scribd.com/doc/26270139>,  
<http://arxiv.org/ftp/arxiv/papers/1002/1002.2405.pdf>
23. Pensky O.G., Monograph "*Mathematical Models of Emotional Robots*", Perm, 2010, 193 ps (in English and Russian) (<http://arxiv.org/ftp/arxiv/papers/1011/1011.1841.pdf>).
24. Pensky O.G., K. V. Chernikov "*Fundamentals of Mathematical Theory of Emotional Robots*" (<http://www.scribd.com/doc/40640088/>).
25. *Wikipedia*. Some background material in this article is gathered from Wikipedia under the Creative Commons license. <http://wikipedia.org> .



One design of aircraft Xb-70

## Chapter 15

# Review of new ideas, innovations of non-rocket propulsion systems for Space Launch and Flight (Part 2)

### Abstract

In the past years the author and other scientists have published a series of new methods which promise to revolutionize the space propulsion systems, space launching and flight. These include the electrostatic AB-ramjet space propulsion, beam space propulsion, MagSail, high speed AB-solar sail, transfer electricity in outer space, simplest AB-thermonuclear space propulsion, electrostatic linear engine and cable space launcher, AB-levitrons, electrostatic climber, AB-space propulsion, convertor any matter in nuclear energy, femtotechnology, wireless transfer of energy, magnetic space launcher, railgun, superconductivity rail gun, etc.

Some of them have the potential to decrease launch costs thousands of time, other allow to change the speed and direction of space apparatus without the spending of fuel.

The author reviews and summarizes some revolutionary propulsion systems for scientists, engineers, inventors, students and the public.

**Key words:** Non-rocket propulsion, non-rocket space launching, non-rocket space flight, electrostatic AB-ramjet space propulsion, beam space propulsion, MagSail, high speed AB-solar sail, transfer electricity in outer space, simplest AB-thermonuclear space propulsion, electrostatic linear engine and launcher, AB-levitrons, electrostatic climber, AB-space propulsion, convertor any matter in nuclear energy, femtotechnology, wireless transfer of energy, magnetic space launcher, railgun, superconductivity railgun.

### Introduction

**Brief history.** Rockets for military and recreational uses date back to at least 13th century China. Modern rockets were born when Goddard attached a supersonic (de Laval) nozzle to a liquid-fueled rocket engine's combustion chamber. These nozzles turn the hot gas from the combustion chamber into a cooler, hypersonic, highly directed jet of gas, more than doubling the thrust and raising the engine efficiency from 2% to 64%. In 1926, Robert Goddard launched the world's first liquid-fueled rocket in Auburn, Massachusetts.

After World War 2 the missile systems have received the great progress and achieved a great success. But rockets are very expensive and have limited possibilities. In the beginning 21th century the researches of non-rocket launch and flight started [1],[5]-[22]. The non-rocket systems which promise to decrease the space launch and flight cost in hundreds times. Some of them are described in this review.

**Current status of non-rocket space launch and flight systems.** Over recent years interference-fit joining technology including the application of space methods has become important in the achievement of space propulsion system. Part results in the area of non-rocket space launch and flight methods have been patented recently or are patenting now.

Professor Bolonkin made a significant contribution to the study of the different types of non-rocket

space launch and flight in recent years [1]-[22] (1982-2011). Some of them are presented in given review.

Electrostatic AB-ramjet space propulsion is researched in [2, Ch.2]; Beam space propulsion is described in [2, Ch. 3]; Magnetic Space Sail is presented in [2, Ch. 4]; High speed AB-solar sail is developed in [2, Ch.5]; Transfer electricity in outer space is offered in [2, Ch. 6]; Simplest AB-thermonuclear space propulsion is suggested in [2] Ch.7; Electrostatic linear engine and cable space launcher is presented in [2, Ch.10]; AB-levitrons are in [2, Ch. 12]; Electrostatic climber is researched in [3, Ch. 4]; AB-space propulsion is presented in [16] and [3, Ch.10]; Wireless transfer of energy is described in [4, Part A, Ch.3]; Magnetic space launcher is offered in [4, Part A, Ch.6]; Railgun Launch System is suggested in [4, Part A, Ch.7]; Superconductivity rail gun is presented in [6] and in [4, Part A, Ch.3]; Convertor any matter in nuclear energy and photon rocket is offered and researched in [4, Part A, Ch.1], [7], [19]; Femtotechnology and its application into aerospace technology is suggested and researched in [4, Part A, Ch.2], [8],[18]. Some of these system were developed in [9]-[23].

Significant scientific, interplanetary and industrial use did not occur until the 20th century, when rocketry was the enabling technology of the Space Age, including setting foot on the Moon.

But rockets are very expensive and have limited possibilities. In the beginning 21th century the researches of non-rocket launch and flight started [1], [5]-[8].Some of them are described in this review.

## **Main types of Non-Rocket Space Propulsion System**

Contents:

1. Electrostatic AB-ramjet space propulsion,
2. Beam space propulsion,
3. MagSail,
4. High speed AB-solar sail,
5. Transfer electricity in outer space,
6. Simplest AB-thermonuclear space propulsion,
7. Electrostatic linear engine and cable space launcher,
8. AB-levitrons,
9. Electrostatic climber,
10. AB-space propulsion,
11. Wireless transfer of energy,
12. Magnetic space launcher,
13. Railgun,
14. Superconductivity rail gun.
15. Convertor any matter in nuclear energy and photon rocket,
16. Femtotechnology and its application into aerospace technology.

### **1. Electrostatic AB-ramjet space propulsion\***

A new electrostatic ramjet space engine is proposed and analyzed. The upper atmosphere (85 - 1000 km) is extremely dense in ions (millions per cubic cm). The interplanetary medium contains positive protons from the solar wind. A charged ball collects the ions (protons) from the surrounding area and a special electric engine accelerates the ions to achieve thrust or decelerates the ions to achieve drag. The thrust may have a magnitude of several Newtons. If the ions are



decelerated, the engine produces a drag and generates electrical energy. The theory of the new engine is developed. It is shown that the proposed engine driven by a solar battery (or other energy source) can not only support satellites in their orbit for a very long time but can also work as a launcher of space apparatus. The latter capability includes launch to high orbit, to the Moon, to far space, or to the Earth atmosphere (as a return thruster for space apparatus or as a killer of space debris). The proposed ramjet is very useful in interplanetary trips to far planets because it can simultaneously produce thrust or drag and large electric energy using the solar wind. Two scenarios, launch into the upper Earth atmosphere and an interplanetary trip, are simulated and the results illustrate the excellent possibilities of the new concept.

-----  
 \* Presented as paper AIAA-2006-6173 to AIAA/AAS Astrodynamics Specialist Conference, 21-24 August 2006, USA. See also <http://arxiv.org/ftp/physics/papers/0701/0701073.pdf>

## **Introduction**

*Brief information about space particles and space environment.* In Earth's atmosphere at altitudes between 200 - 400 km, the concentration of ions reaches several million per cubic cm. In the interplanetary medium at Earth orbit, the concentration of protons from the Solar Wind reaches 3 - 70 particles per cubic cm. In an interstellar medium the average concentration of protons is about one particle in 1 cm<sup>3</sup>, but in the space zones HII (planetary nebulas), which occupy about 5% of interstellar space, the average particle density may be 10<sup>-20</sup> g/cm<sup>3</sup> (10<sup>6</sup> particles in 1 cm<sup>3</sup>). If we can collect these space particles from a large area, accelerate and brake them, we can get the high speed and braking of space apparatus and to generate energy. The author is suggesting the method of collection and implementations of it for propulsion and braking systems and electric generators. He developed the initial theory of these systems.

### ***Short Description of the Implémentation***

A *Primary Ramjet* propulsion engine is shown in Figure 1-1. Such an engine can work in one charge environment. For example, the surrounding region of space medium contains the positive charge particles (protons, ions). The engine has two plates 1, 2, and a source of electric voltage and energy (storage) 3. The plates are made from a thin dielectric film covered by a conducting layer. As the plates may be a net. The source can create an electric voltage  $U$  and electric field (electric intensity  $E$ ) between the plates. One also can collect the electric energy from plate as an accumulator.

The engine works in the following way. Apparatus are moving (in left direction) with velocity  $V$  (or particles 4 are moving in right direction). If voltage  $U$  is applied to the plates, it is well-known that main electric field is only between plates. If the particles are charged positive (protons, positive ions) and the first and second plate are charged positive and negative, respectively, then the particles are accelerated between the plates and achieve the additional velocity  $v > 0$ . The total velocity will be  $V+v$  behind the engine (Figure 1a). This means that the apparatus will have thrust  $T > 0$  and spend electric energy  $W < 0$  (bias, displacement current). If the voltage  $U = 0$ , then  $v = 0$ ,  $T = 0$ , and  $W = 0$  (Figure 1-b).

If the first and second plates are charged negative and positive, respectively, the voltage changes sign. Assume the velocity  $v$  is satisfying  $-V < v < 0$ . Thus the particles will be broken and the engine (apparatus) will have drag and will also be broken. The engine transfers broke vehicle energy into electric (bias, displacement) current. That energy can be collected and used. Note that velocity  $v$  cannot



equal  $-V$ . If  $v$  were equal to  $-V$ , that would mean that the apparatus collected positive particles, accumulated a big positive charge and then repelled the positive charged particles.

If the voltage is enough high, the brake is the highest (Figure 1-1d). Maximum braking is achieved when  $v = -2V$  ( $T < 0$ ,  $W = 0$ ). Note, the  $v$  cannot be more then  $-2V$ , because it is full reflected speed.

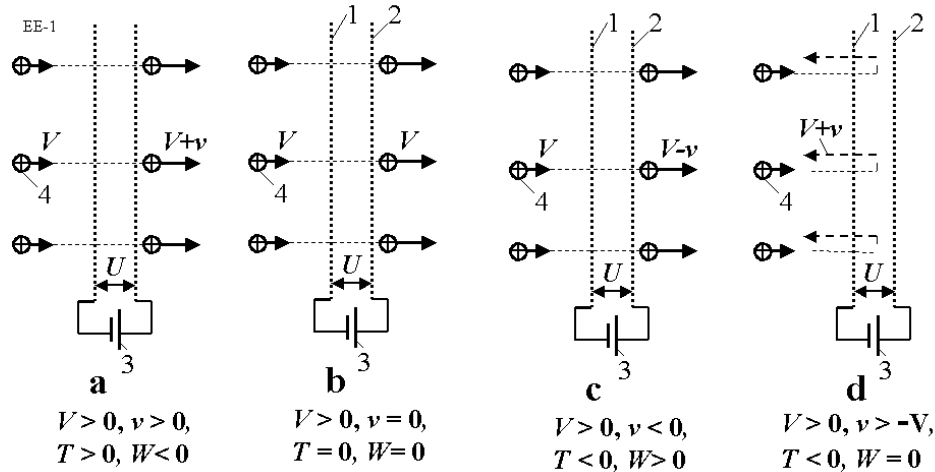


Figure 1-1. Explanation of primary Space Ramjet propulsion (engine) and electric generator (in braking), a) Work in regime thrust; b) Idle; c) Work in regime brake. d) Work in regime strong brake (full reflection). Notation: 1, 2 - plate (film, thin net) of engine; 3 - source of electric energy (voltage  $U$ ); 4 - charged particles (protons, ions);  $V$  - speed of apparatus or particles before engine (solar wind);  $v$  - additional speed of particles into engine plates;  $T$  - thrust of engine;  $W$  - energy (if  $W < 0$  we spend energy).

**AB-Ramjet engine.** The suggested Ramjet is different from the primary ramjet. The suggested ramjet has specific electrostatic collector 5 (Figure 1-2a,c,d,e,f,g). Other authors said the idea of space matter collection. But they did not give the principal design of collector. Their electrostatic collector cannot work. Really, for charging of collector we must move away from apparatus the charges. The charged collector attracts the same amount of the charged particles (charged protons, ions, electrons) from space medium. They discharged collector. All your work will be idle. That cannot work.

The electrostatic collector cannot absorb a matter (as offered some inventors) because it can absorb ONLY opposed charges particles, which will be discharged the initial charge of collector. Physic law of conservation of charges does not allow changing the charges of particles.

The suggested collector and ramjet engine have a special design (thin film, net, special form of charge collector, particle accelerator). The collector/engine passes the charged particles ACROSS (through) the installation and changes their energy (speed), deflecting and focusing them. That is why we refer to this engine as the *AB-Ramjet engine*. It can create thrust or drag, extract energy from the kinetic energy of particles or convert the apparatus' kinetic energy into electric energy, and deflect and focus the particle beam. The collector creates a local environment in space because it deletes (repels) the same charged particles (electrons) from apparatus and allows the Ramjet to work when the apparatus speed is close to zero. The author developed the theory of the electrostatic collector. The conventional electric engine cannot work in usual plasma without the main part of the AB-engine - the special pervious electrostatic collector.

The plates of the suggested engine are different from the primary engine. They have a concentrically septa (partitions) which create additional radial electric fields (electric intensity) (Figure 1-2b). They straighten, deflect and focus the particle beams and improve the efficiency coefficient of the engine.

The central charge can have a different form (core) and design (Figure 2 c,d,e,f,g,h). It may be:

- (1) a sphere (Figure 1-2c) having a thin cover of plastic film and a very thin (some nanometers) conducting layer (aluminum), with the concentric spheres inserted one into the other (Figure 1-2d),
- (2) a net formed from thin wires (Figure 1-2e);
- (3) a cylinder (without butt-end)(Figure 1-2f); or
- (4) a plate (Figure 1-2g).

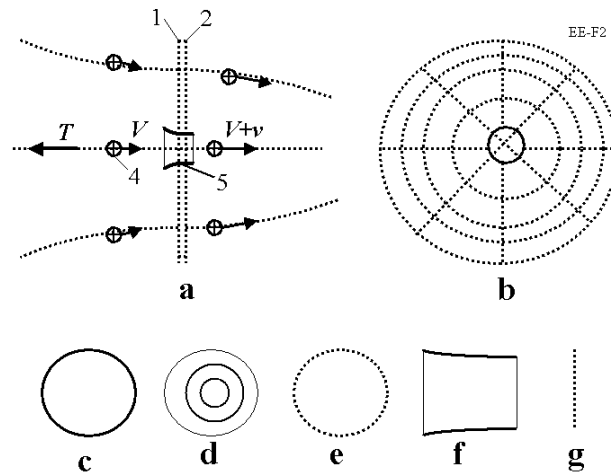


Figure 1-2. Space AB-Ramjet engine with electrostatic collector (core). a) Side view; b) Front view; c) Spherical electrostatic collector (ball); d) Concentric collector; e) cellular (net) collector; f) cylindrical collector without cover butt-ends; g) plate collector (film or net).

The design is chosen to produce minimum energy loss (maximum particle transparency). The safety (from discharging, emission of electrons) electric intensity in a vacuum is  $10^8$  V/m for an outer conducting layer and negative charge. The electric intensity is more for an inside conducting layer and thousands of times more for positive charge.

The engine plates are attracted one to the other. They can have different designs (Figure 1-3a - 3d). In the rotating film or net design (Figure 1-3a), the centrifugal force prevents contact between the plates. In the inflatable design (Figure 1-3b), the low pressure gas prevents plate contact. A third design has (inflatable) rods supporting the film or net (Figure 1-3c). The fourth design is an inflatable toroid which supports the distance between plates or nets (Figure 1-3d).

*Electric gun.* The simplest electric gun (linear particle accelerator) for charging an apparatus ball is presented in Figure 1-4. The design is a long tube (up 10 m) which creates a strong electric field along the tube axis (100 MV/m and more). The gun consists of the tube with electrical isolated cylindrical electrodes, ion source, microwave frequency energy source, and voltage multiplier. This electric gun can accelerate charged particles up 1000 MeV. Electrostatic lens and special conditions allow the creation of a focusing and self-focusing beam which can transfer the charge and energy long distances into space. The engine can be charged from a satellite, a space ship, the Moon, or a top atmosphere

station. The beam may also be used as a particle beam weapon.

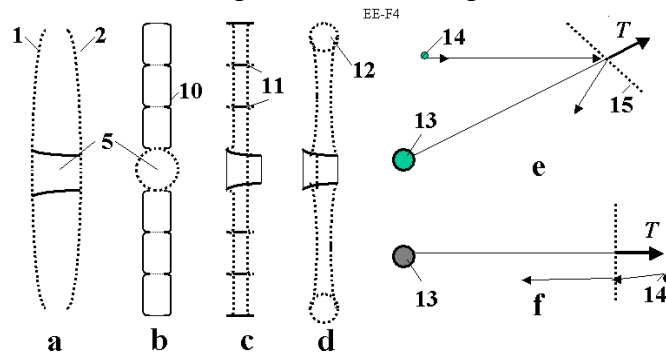


Figure 1-3. Possible design of the main part of ramjet engine. a) Rotating engine; b) Inflatable engine (filled by gas); c) Rod engine; d) Toroidal shell engine, e) AB-Ramjet engine in brake regime, f) AB-Ramjet engine in thrust regime. Notation: 10 - film shells (fibers) for support thin film and creating a radial electric field; 11 - Rods for a support the film or net; 12 - inflatable toroid for support engine plates; 13 - space apparatus; 14 - particles; 15 - AB-Ramjet.

Approximately tens years ago, the conventional linear pipe accelerated protons up to 40 MeV with a beam divergence of  $10^{-3}$  radian. However, acceleration of the multi-charged heavy ions may result in significantly more energy.

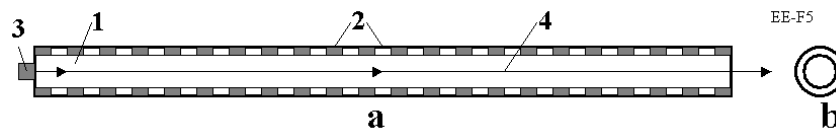


Figure 1-4. Electric gun for charging AB-Ramjet engine and transfer charges (energy) in long distance. a) Side view, b) Front view. *Notations:* 1 - gun tube, 2 - opposed charged electrodes, 3 - source of charged particles (ions, electrons), 4 - particles beam.

At present, the energy gradients as steep as 200 GeV/m have been achieved over millimeter-scale distances using laser pulsars. Gradients approaching 1 GeV/m are being produced on the multi-centimeter-scale with electron-beam systems, in contrast to a limit of about 0.1 GeV/m for radio-frequency acceleration alone. Existing electron accelerators such as SLAC <http://en.wikipedia.org/wiki/SLAC> could use electron-beam afterburners to increase the intensity of their particle beams. Electron systems in general can provide tightly collimated, reliable beams while laser systems may offer more power and compactness.

## Conclusion

The primary research and computations of the suggested AB-engine show the numerous possibilities and perspectives of the space AB-ramjet engines. The density of the charged space particles is very small. But the proposed electrostatic collector can effectively gather the particles from a huge surrounding area and accelerate or brake them, generating thrust or braking on the order of several Newtons. The high speed solar wind allows simultaneously obtainment of useful drag (thrust) and great electrical energy. The simplest electrostatic gatherer accelerates a 100 kg probe up to a velocity of 100 km/s. The probe offers flights into Mars orbit of about 70 days, to Jupiter orbit in about 150 days, to Saturn orbit in about 250 days, to Uranus orbit in about 450 days, to Neptune orbit in about 650 days, and to Pluto orbit in about 850 days.

The suggested electric gun is simple and can transfer energy (charge by electron beam) over a long distance to other space apparatus.

The author has developed the initial theory and the initial computations to show the possibility of the offered concepts. He calls on scientists, engineers, space organizations, and companies to research and develop the proposed perspective concepts.

## 2. BEAM SPACE PROPULSION\*

The author offers a revolutionary method - non-rocket transfer of energy and thrust into Space with distance of millions kilometers. The author has developed theory and made the computations. The method is more efficient than transmission of energy by high-frequency waves. The method may be used for space launch and for acceleration the spaceship and probes for very high speeds, up to relativistic speed by current technology. Research also contains prospective projects which illustrate the possibilities of the suggested method.

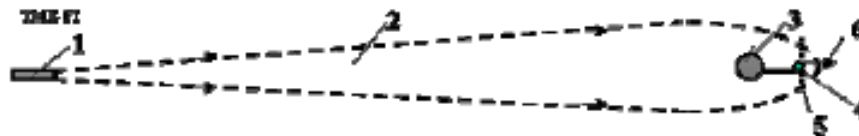
### Description of Innovation

Innovative installation for transfer energy and impulse includes (Figure 2-1): the ultra-cold plasma injector, electrostatic collector, electrostatic electro-generator-thruster-reflector, and space apparatus. The plasma injector creates and accelerates the ultra-cold low density plasma. The Installation works the following way: the injector-accelerator forms and injects the cold neutral plasma beam with high speed in spaceship direction. When the beam reaches the ship, the electrostatic collector of spaceship collects and separates the beam ions from large area and passes them through the engine-electric generator or reflects them by electrostatic mirror. If we want to receive the thrust in the near beam direction ( $\pm 90^\circ$ ) and electric energy, the engine works as thruster (accelerator of spaceship and braker of beam) in beam direction and electric generator. If we want to get thrust in opposed beam direction, the space engine must accelerate the beam ions and spend energy. If we want to have maximum thrust in beam direction, the engine works as full electrostatic mirror and produces double thrust in the beam direction (full reflection of beam back to injector). The engine does not spend energy for full reflection.

The thrust is controlled by the electric voltage between engine nets, the thrust direction is controlled by the engine nets angle to beam direction. Note, the trust can brake the ship (decrease the tangential ship speed) and far ship (located out of Earth orbit) can return to the Earth by Sun gravity.

Note also, the Earth atmosphere absorbs and scatters the plasma beam and the beam injector must be located on Earth space mast or tower (up 40 ÷ 60 km) or the Moon. Only high energy beam can break through atmosphere with small divergence. The advantage: the injector has a reflector and when the ship locates not far from the injector the beam will be reflected a lot of times and thrust increases in thousand times at start (Figure 2-2).

The proposed engine may be also used as AB-ramjet engine, utilizing the Solar wind or interstellar particles.



\* Presented as paper AIAA-2006-7492 to Conference "Space-2006", 19-21 September, 2006, San-Jose, CA, USA. See also <http://arxiv.org/ftp/physics/papers/0701/0701057.pdf>

Figure 2-1. Long distance space transfer of electric energy, matter, and momentum (thrust). Notation are: 1 - injector-accelerator of neutral ultra-cold plasma (ions and electrons), 2 - plasma beam, 3 - space ship or planetary team, 4 - electrostatic ions collector (or magnetic collector), 5 - braking electric nets (electrostatic electro-generator-thruster-reflector), 6 - thrust.

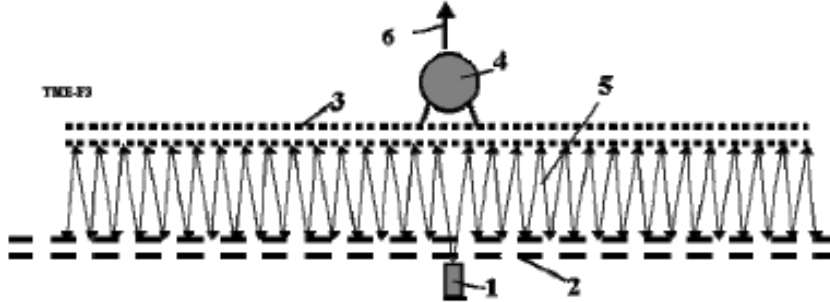


Figure 2-2. Multi-reflection start of the spaceship having proposed engine. Notation are: 1 - injector-accelerator of cold ions or plasma, 2, 3 - electrostatic reflectors, 4 - space ship, 5 - plasma beam, 6 - the thrust.

The electrostatic collector and electrostatic generator-thruster-reflector proposed and described in chapter 1 above. The main parts are presented below.

A *Primary Ramjet* propulsion engine is shown in Figure 2-1 Chapter 1. Such an engine can work in charged environment. For example, the surrounding region of space medium contains positive charge particles (protons, ions). The engine has two plates 1, 2, and a source of electric voltage and energy (storage) 3. The plates are made from a thin dielectric film covered by a conducting layer. The plates may be a net. The source can create an electric voltage  $U$  and electric field (electric intensity  $E$ ) between the plates. One also can collect the electric energy from plate as an accumulator.

The engine works in the following way. Apparatus are moving (in left direction) with velocity  $V$  (or particles 4 are moving in right direction). If voltage  $U$  is applied to the plates, it is well-known that main electric field is only between plates. If the particles are charged positive (protons, positive ions) and the first and second plate are charged positive and negative, respectively, then the particles are accelerated between the plates and achieve the additional velocity  $v > 0$ . The total velocity will be  $V+v$  behind the engine (Figure 2-1a, Ch. 2). This means that the apparatus will have thrust  $T > 0$  and spend electric energy  $W < 0$  (bias, displacement current). If the voltage  $U = 0$ , then  $v = 0$ ,  $T = 0$ , and  $W = 0$  (Figure 1-1b, Ch.1).

If the first and second plates are charged negative and positive, respectively, the voltage changes sign. Assume the velocity  $v$  is satisfying  $-V < v < 0$ . Thus the particles will be braked and the engine (apparatus) will have drag and will also be braked. The engine transfers braked vehicle energy into electric (bias, displacement) current. That energy can be collected and used. Note that velocity  $v$  cannot equal  $-V$ . If  $v$  were equal to  $-V$ , that would mean that the apparatus collected positive particles, accumulated a big positive charge and then repelled the positive charged particles.

If the voltage is high enough, the brake is the highest (Figure 1-1d, Ch.1). Maximum braking is achieved when  $v = -2V$  ( $T < 0$ ,  $W = 0$ ). Note, the  $v$  cannot be more then  $-2V$ , because it is full reflected speed.

*AB-Ramjet engine.* The suggested Ramjet is different from the primary ramjet. The suggested ramjet has specific electrostatic collector 5 (Figure 1-2a,c,d,e,f,g, Ch. 1). Other authors have outline the idea of space matter collection, but they did not describe and not research the principal design of collector. Really, for charging of collector we must move away from apparatus the charges. The charged collector attracts the same amount of the charged particles (charged protons, ions, electrons) from space medium. They discharged collector, work will be idle. That cannot be useful.

The electrostatic collector cannot adsorb matter (as offered some inventors) because it can adsorb ONLY opposed charges particles, which will be discharged the initial charge of collector. Physic law of conservation of charges does not allow to change charges of particles.

The suggested collector and ramjet engine have a special design (thin film, net, special form of charge collector, particle accelerator). The collector/engine passes the charged particles ACROSS (through) the installation and changes their energy (speed), deflecting and focusing them. That is why we refer to this engine as the *AB-Ramjet engine*. It can create thrust or drag, extract energy from the kinetic energy of particles or convert the apparatus' kinetic energy into electric energy, and deflect and focus the particle beam. The collector creates a local environment in space because it deletes (repels) the same charged particles (electrons) from apparatus and allows the Ramjet to work when the apparatus speed is close to zero. The author developed the theory of the electrostatic collector and published it in [26]. The conventional electric engine cannot work in usual plasma without the main part of the AB-engine - the special pervious electrostatic collector.

The plates of the suggested engine are different from the primary engine. They have concentric partitions which create additional radial electric fields (electric intensity) (Figure 1-2b, Ch.1). They straighten, deflect and focus the particle beams and improve the efficiency coefficient of the engine.

The central charge can have a different form (core) and design (Figure 2-2 c,d,e,f,g,h, Ch.2). It may be:

- (1) a sphere (Figure 1-2c, Ch. 1) having a thin cover of plastic film and a very thin (some nanometers) conducting layer (aluminum), with the concentric spheres inserted one into the other (Figure 1-2d, Ch. 1),
- (2) a net formed from thin wires (Figure 1-2e, Ch. 1);
- (3) a cylinder (without butt-end)(Figure 1-2f, Ch. 1); or
- (4) a plate (Figure 1-2g, Ch. 1).

The design is chosen to produce minimum energy loss (maximum particle transparency - see section "Theory" in [2] Ch.3). The safety (from discharging, emission of electrons) electric intensity in a vacuum is  $10^8$  V/m for an outer conducting layer and negative charge. The electric intensity is more for an inside conducting layer and thousands of times more for positive charge.

The engine plates are attracted one to the other (see theoretical section in [2] Ch.3). They can have various designs (Figure 1-3a - 3d, Ch. 1). In the rotating film or net design (Figure 1-3a, Ch. 1), the centrifugal force prevents contact between the plates. In the inflatable design (Figure 1-3b, Ch. 1), the low pressure gas prevents plate contact. A third design has (inflatable) rods supporting the film or net (Figure 1-3c, Ch. 1). The fourth design is an inflatable toroid which supports the distance between plates or nets (Figure 1-3d, Ch.1).

Note, the AB-ramjet engine can work using the neutral plasma. The ions will be accelerated or braked, the electrons will be conversely braked or accelerated. But the mass of the electrons is less then the mass of ions in thousands times and AB-engine will produce same thrust or drag.

*Plasma accelerator.* The simplest linear plasma accelerator (principle scheme of linear particle accelerator) for plasma beam is presented in Figure 1-4, Ch. 1. The design is a long tube (up 10 m) which creates a strong electric field along the tube axis (100 MV/m and more). The accelerator consists of the tube with electrical isolated cylindrical electrodes, ion source, and voltage multiplier. The accelerator increases speed of ions, but in end of tube into ion beam the electrons are injected. This plasma accelerator can accelerate charged particles up 1000 MeV. Electrostatic lens and special conditions allow the creation of a focusing and self-focusing beam which can transfer the charge and energy long distances into space. The engine can be charged from a satellite, a spaceship, the Moon, or a top atmosphere station. The beam may also be used as a particle beam weapon.





connect and produce photons of very closed energy (laser beam). If we compress very quickly by explosion the power of beam will be high. The power is only limited amount of plasma energy.

After recombination ions and electrons we receive the conventional matter. This matter may be used as nuclear fuel (in thermonuclear reactor), medicine, food, drink, oxidizer for breathing, etc.

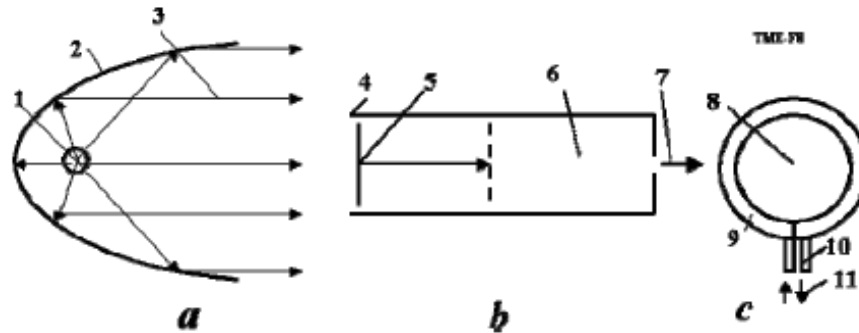


Figure 2-4. Conversion of ionization energy into radiation and heat. *a* - photon engine; *b* - power laser (light beam); *c* - heater. Notations: 1 - recombination reactor; 2 - mirror; 3 - radiation (light) beam; 5 - piston; 6 - volume filled by cold rare plasma; 7 - beam; 8 - plasma; 9 - heat exchanger; 10 - enter and exit of heat carrier; 11 - heat carrier.

## Conclusion

The offered idea and method use the AB-Ramjet engine suggested by author in 1982 [2- 4] and detail developed in [2]. The installation contains an electrostatic particle collector suggested in 1982 and detail developed in [2]. The propulsion-reflected system is light net from thin wire, which can have a large area (tens km) and allows to control thrust and thrust direction without turning of net (Figure 1). This new method uses the ultra-cold full neutral relativistic plasma and having small divergence. The method may be used for acceleration space apparatus (up relativistic speed) for launch and landing Space apparatus to small planets (asteroids, satellites) without atmosphere. For Earth offered method will be efficiency if we built the tower (mast) about 40 ÷ 80 km height. At present time that is the most realistic method for relativistic probe.

## 3. Space Magnetic Sail\*

The first reports on the “Space Magnetic Sail” concept appeared more 30 years ago. During the period since some hundreds of research and scientific works have been published, including hundreds of research report by professors at major famous universities. The author herein shows that all these works related to Space Magnetic Sail concept are technically incorrect because their authors did not take into consideration that solar wind impinging a MagSail magnetic field creates a particle magnetic field opposed to the MagSail field. In the incorrect works, the particle magnetic field is hundreds times stronger than a MagSail magnetic field. That means all the laborious and costly computations in revealed in such technology discussions are useless: the impractical findings on sail thrust (drag), time of flight within the Solar System and speed of interstellar trips are essentially worthless working data! The author reveals the correct equations for any estimated performance of a Magnetic Sail as well as a new type of Magnetic Sail (without a matter ring).

\* Presented as paper AIAA-2006-8148 to 14th AIAA/AHI Space Planes and Hypersonic Systems and Technologies Conference, 6 - 9 Nov 2006 National Convention Centre, Canberra, Australia. See also [2, Ch.4],

<http://www.scribd.com/doc/24057071> .

<http://www.archive.org/details/NewConceptsIfeasAndInnovationsInAerospaceTechnologyAndHumanSciences>

## ***New Electrostatique MagSail (EMS)***

The conventional MagSail with super-conductive ring has big drawbacks:

1. It is very difficult to locate gigantic (tens of km radius) ring in outer space.
2. It is difficult to insert a big energy into superconductive ring.
3. Super-conductive ring needs a low temperature to function at all. The Sun heats all bodies in the Solar System to a temperature higher than temperature of super-conductive materials.
4. The super-conductive ring explodes if temperature is decreased over critical value.
5. It is difficult to control the value of MagSail thrust and the thrust direction.

The author offers new Electrostatic MagSail (EMS). The innovation includes the central positive charged small ball and a negative electronic equal density ring rotated around the ball (Figure 3-1).

The suggested EMS has the following significant advantages in comparison with conventional MagSail:

- (1) No heavy super-conductive large ring.
- (2) No cooling system for ring is required.
- (3) Electronic ring is safe.
- (4) The thrust (ring radius) easy changes by changing of ball charge.

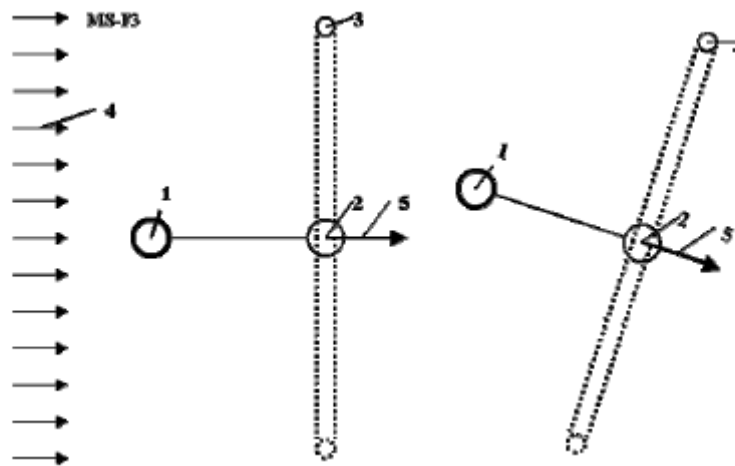


Figure 3-1. Electrostatic MagSail. Notations: 1-Spaceship; 2-Positive charged ball; 3-electrical ring; 4-solar wind; 5-EMS drag. In right side the EMS in turn position.

## **4. HIGH SPEED AB-SOLAR SAIL\***

The Solar sail is a large thin film used to collect solar light pressure for moving of space apparatus. Unfortunately, the solar radiation pressure is very small about  $9 \mu\text{N/mm}$  at Earth's orbit. However, the light force significantly increases up to  $0.2 - 0.35 \text{ N/mm}$  near the Sun. The author offers his research on a new revolutionary highly reflective solar sail which flyby (after special maneuver) near Sun and attains velocity up to  $400 \text{ km/sec}$  and reaching far planets of the Solar

\* This work is presented as paper AIAA-2006-4806 for 42 Joint Propulsion Conference, Sacramento, USA, 9-12 July, 2006. See also <http://arxiv.org/ftp/physics/papers/0701/0701073.pdf> or [2, Ch.5].

system in short time or enable flights out of Solar system. New, highly reflective sail-mirror allows avoiding the strong heating of the solar sail. It may be useful for probes close to the Sun and Mercury and Venus.

## Description and Innovations

*Description.* The suggested AB space sail is presented in Figure 4-1. It consists of: a thin high reflection film (solar sail) supported by an inflatable ring (or other method), space apparatus connected to solar sail, a heat screen defends the apparatus from solar radiation.

The thin film includes millions of very small prisms (angle  $45^\circ$ , side  $3 \div 30 \mu\text{m}$ ). The solar light is totally reflected back into the incident medium. This effect is called total internal reflection. Total internal reflection is used in the proposed reflector. As it is shown in [1, Ch.12] the light absorption is very small ( $10^{-5} \div 10^{-7}$ ) and radiation heating is small (see computation section). Another possible design for the suggested solar sail is presented in Figure 4-2. Here solar sail has concave form (or that plate is made like Fresnel mirror).

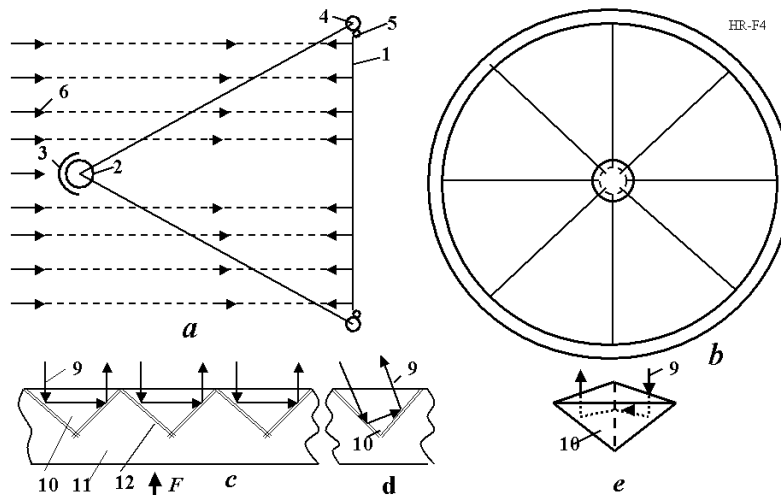


Figure 4-1. High reflective space AB-sail. (a) Side view of AB-sail; (b) Front view; (c) cross-section of sail surface; (d) case of non-perpendicular solar beam; (e) triangle reflective sell. Notation: 1 - thin film high reflective AB-mirror, 2 - space apparatus, 3 - high reflective heat screen (shield) of space apparatus, 4 - inflatable support thin film ring, 5 - inflatable strain ring, 6 - solar light, 9 - solar beam, 10 - reflective sell, 11 - substrate, 12 - gap.

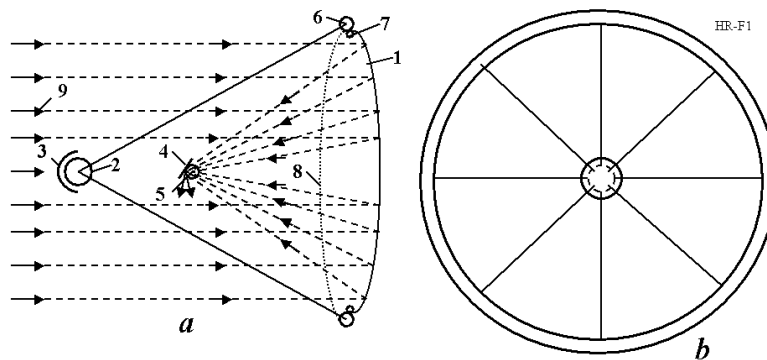


Figure 4-2. AB highly reflective solar sail with concentrator. (a) side view; (b) front view. Notation: 1 - highly reflective AB mirror (it may have a Fresnel form), 2 - space apparatus, 3 - high reflective heat screen, 4 - control mirror, 5 - reflected solar beam, 6 - inflatable support thin film ring, 7 - inflatable strain ring, 8 - thin transparent film, 9 - solar beam.

The sail concentrates solar light on a small control mirror 4. That mirror allows re-directed (reflected) solar beam and to change value and direction of the sail thrust without turning the large solar sail. Between thin films 1, 8 there is a small gas pressure which supports the concave form of reflector 1. Concentration of energy can reach  $10^3 \div 10^4$  times, temperature greater than 5000 °K. This energy may be very large. For the sail of 200×200 m, at Earth orbit the energy is  $5.6 \times 10^4$  kW. This energy may be used for apparatus propulsion or other possibilities (see [5]), for example, to generate electricity. The concave reflector may be also utilized for long-distance radio communication.

The trajectory of the high speed solar AB-sail is shown in Figure 4-3. The sail starts from Earth orbit. Then is accelerated by a solar light to up 11 km/s in opposed direction of Earth moving around Sun and leaves Earth gravitational field. The Earth has a speed about 29 km/s in its around Sun orbit. The sail will be have  $29 - 11 = 18$  km/s. That is braked and moves to Sun (trajectory 4). Near the Sun the reflector is turned for acceleration to get a high speed (up to 400 km/s) from a powerful solar radiation. The second solar space speed is about 619 km/s. If AB sail makes three small revolutions around Sun, it can then reach speed of a 1000 km/s and leaves the Solar system with a speed about 400 km/s. Suggested highly reflective screen protects the apparatus from an excessive solar heating. Note, the offered AB sail allows also to brake an apparatus very efficiency from high speed to low speed. If we send AB sail to another star, it can brake at that star and became a satellite of the star (or a planet of that solar system).

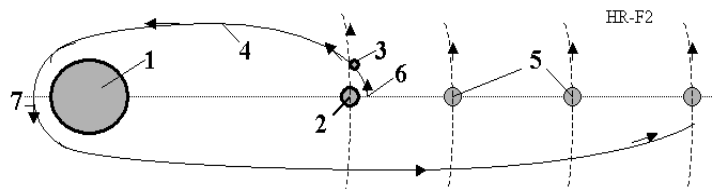


Figure 4-3. Maneuvers of AB solar sail for reaching a high speed: braking for flyby near Sun, great acceleration from strong solar radiation and flight away to far planets or out of our Solar system. Notation: 1 - Sun, 2 - Earth, 3 AB Solar sail, 4 - trajectory of solar sail to Sun, 5 - other planets, 6, 7 - speed of solar sail.

## Conclusion

The suggested new AB sail can fly very close to the Sun's surface and get high speed which is enough for quick flight to far planets and out of our Solar System. Advantages allow: 1) to get very high speed up 400 km/s; 2) easy to control an amount and direction of thrust without turning a gigantic sail; 3) to utilize of the solar sail as a power generator (for example, electricity generator); 4) to use the solar sail for long-distance communication systems.

The same researches were made by author for solar wind sail and other propulsion [1]-[4].

## 5. TRANSFER OF ELECTRICITY IN OUTER SPACE\*

Author offers conclusions from his research of a revolutionary new idea - transferring electric energy in the hard vacuum of outer space wirelessly, using a plasma power cord as an electric cable (wire). He shows that a certain minimal electric current creates a compressed force that supports the plasma cable in the compacted form. A large energy can be transferred hundreds of millions of kilometers by this method. The required mass of the plasma cable is only hundreds of grams. He

\* Presented as Bolonkin's paper AIAA-2007-0590 to 45th AIAA Aerospace Science Meeting, 8 - 11 January 2007, Reno, Nevada, USA. See also <http://arxiv.org/ftp/physics/papers/0701/0701058.pdf>.

computed the macroprojects: transference of hundreds kilowatts of energy to Earth's Space Station, transferring energy to the Moon or back, transferring energy to a spaceship at distance 100 million of kilometers, the transfer energy to Mars when one is located at opposed side of the distant Sun, transfer colossal energy from one of Earth's continents to another continent (for example, between Europe-USA) wirelessly—using Earth's ionosphere as cable, using Earth as gigantic storage of electric energy, using the plasma ring as huge MagSail for moving of spaceships. He also demonstrates that electric currency in a plasma cord can accelerate or brake spacecraft and space apparatus.

### ***Innovations and Bref Descriptions***

The author offers the series of innovations that may solve the many macro-problems of transportation energy in space, and the transportation and storage energy within Earth's biosphere. Below are some of them.

- (1) Transfer of electrical energy in outer space using the conductive cord from plasma. Author solved the main problem - how to keep plasma cord in compressed form. He developed theory of space electric transference, made computations that show the possibility of realization for these ideas with existing technology. The electric energy may be transferred in hundreds millions of kilometers in space (include Moon and Mars).
- (2) Method of construction for space electric lines and electric devices.
- (3) Method of utilization of the plasma cable electric energy.
- (4) A new very perspective gigantic plasma MagSail for use in outer space as well as a new method for connection the plasma MagSail to spaceship.
- (5) A new method of projecting a big electric energy through the Earth's ionosphere.
- (6) A new method for storage of a big electric energy used Earth as a gigantic spherical condenser.
- (7) A new propulsion system used longitudinal (cable axis) force of electric currency.

Below there are some succinct descriptions of some constructions made possible by these revolutionary ideas.

#### **1. Transferring Electric Energy in Space**

The electric source (generator, station) is connected to a space apparatus, space station or other planet by two artificial rare plasma cables (Figure 5-1a). These cables can be created by plasma beam [2] sent from the space station or other apparatus.

The plasma beam may be also made the space apparatus from an ultra-cold plasma [2] when apparatus starting from the source or a special rocket. The plasma cable is self-supported in cable form by magnetic field created by electric currency in plasma cable because the magnetic field produces a magnetic pressure opposed to a gas dynamic plasma pressure (teta-pinch)(Figure 5-2). The plasma has a good conductivity (equal silver and more) and the plasma cable can have a very big cross-section area (up thousands of square meter). The plasma conductivity does not depend on its density. That way the plasma cable has a no large resistance although the length of plasma cable is hundreds millions of kilometers. The needed minimum electric currency from parameters of a plasma cable researched in theoretical section of this article.

The parallel cables having opposed current repels one from other (Figure 1a). They also can be separated by a special plasma reflector as it shown in figs. 5-1b, 5-1c. The electric cable of the plasma transfer can be made circular (Figure 5-1c).

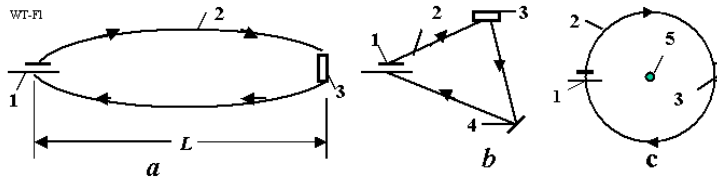


Figure 5-1. Long distance plasma transfer electric energy in outer space. a - Parallel plasma transfer, b - Triangle plasma transfer, c - circle plasma transfer. Notations: 1 - current source (generator), 2 - plasma wire (cable), 3 - spaceship, orbital station or other energy addresses, 4 - plasma reflector, 5 - central body.

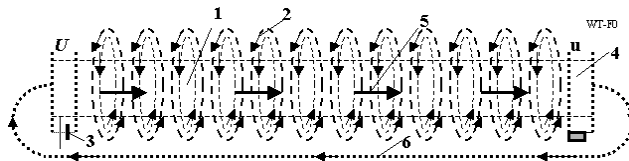


Figure 5-2. A plasma cable supported by self-magnetic field. Notations: 1 - plasma cable, 2 - compressing magnetic field, 3 - electric source, 4 - electric receiver, 5 - electric current, 6 - back plasma line.

The radial magnetic force from a circle current may be balanced electric charges of circle and control body or/and magnetic field of the space ship or central body (see theoretical section). The circle form is comfortable for building the big plasma cable lines for spaceship not having equipment for building own electric lines or before a space launch. We build small circle and gradually increase the diameter up to requisite value (or up spaceship). The spaceship connects to line in suitable point. Change the diameter and direction of plasma circle we support the energy of space apparatus. At any time the spaceship can disconnect from line and circle line can exist without user.

The electric tension (voltage) in a plasma cable is made two nets in issue electric station (electric generator). The author offers two methods for extraction of energy from the electric cable (Figure 3) by customer (energy addresses). The plasma cable current has two flows: electrons (negative) flow and opposed ions (positive) flow in one cable. These flows create an electric current. (It may be instances when ion flow is stopped and current is transferred only the electron flow as in a solid metal or by the ions flow as in a liquid electrolyte. It may be the case when electron-ion flow is moved in same direction but electrons and ions have different speeds). In the first method the two nets create the opposed electrostatic field in plasma cable (resistance in the electric cable) (figs. 5-1, 5-3b). This apparatus resistance utilizes the electric energy for the spaceship or space station. In the second method the charged particles are collected a set of thin films (Figure 3a) and emit (after utilization in apparatus) back into continued plasma cable (Figure 5-3a).

Figure 5-3c presents the plasma beam reflector. That has three charged nets. The first and second nets reflect (for example) positive particles, the second and third nets reflected the particles having an opposed charge.

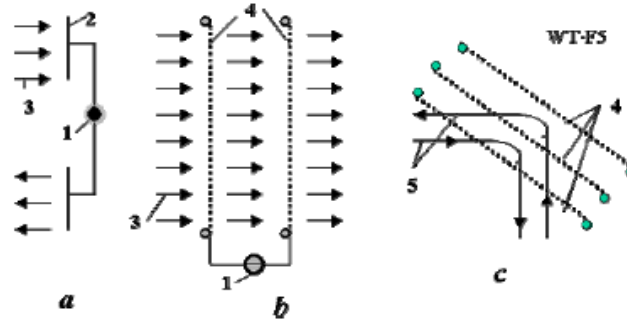


Figure 5-3. Getting the plasma current energy from plasma cable. a - getting by two thin conducting films; b - getting two nets which brake the electric current flux; c - plasma reflector. Notations: 1 - spaceship or space station, 2 - set (films) for collect (emit) the charged particles, 3 - plasma cable, 4 - electrostatic nets.

## 2. Transmitting of the Electric Energy to Satellite, Earth's Space Station, or Moon.

The suggested method can be applied for transferring of electric energy to space satellites and the Moon. For transmitting energy from Earth we need a space tower of height up 100 km, because the Earth's atmosphere will wash out the plasma cable or we must spend a lot of energy for plasma support. The design of solid, inflatable, and kinetic space towers are revealed in [1]-[13]-[4] and in Review of Space Towers into this Collection.

It is possible this problem may be solved with an air balloon located at 30-45 km altitude and connected by conventional wire with Earth's electric generator. Further computation can make clear this possibility.

If transferring valid for one occasion only, that can be made as the straight plasma cable 4 (Figure 5-4). For multi-applications the elliptic closed-loop plasma cable 6 is better. For permanent transmission the Earth must have a minimum two space towers (Figure 5-4). Many solar panels can be located on Moon and Moon can transfer energy to Earth.

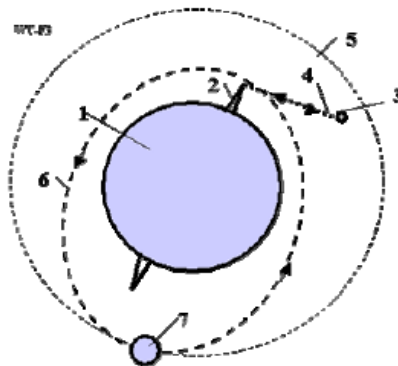


Figure 5-4. Transferring electric energy from Earth to satellite, Earth's International Space Station or to Moon (or back) by plasma cable. Notations: 1 - Earth, 2 - Earth's tower 100 km or more, 3 - satellite or Moon, 4 - plasma cable, 5 - Moon orbit, 6 - plasma cable to Moon, 7 - Moon.

## 3. Transferring Energy to Mars

The offered method may be applied for transferring energy to Mars including the case when Mars may be located in opposed place of Sun [2, Ch.6].

## 4. Plasma AB Magnetic Sail

Very interesting idea to build a gigantic plasma circle and use it as a Magnetic Sail (Figure 5-5) harnessing the Solar Wind. The computations show (see section "Macroproject") that the electric resistance of plasma cable is small and the big magnetic energy of plasma circle is enough for



existence of a working circle in some years without external support. The connection of spaceship to plasma is also very easy. The space ship create own magnetic field and attracts to MagSail circle (if spacecraft is located behind the ring) or repels from MagSail circle (if spaceship located ahead of the ring). The control (turning of plasma circle) is also relatively easy. By moving the spaceship along the circle plate, we then create the asymmetric force and turning the circle. This easy method of building the any size plasma circle was discussed above.

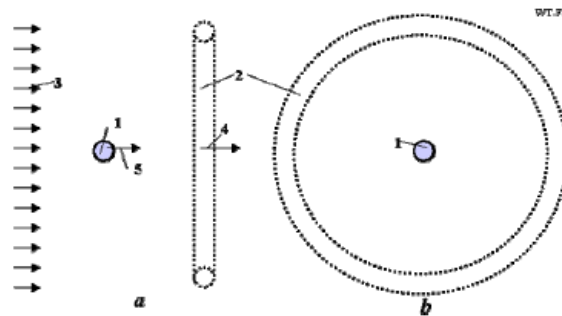


Figure 5-5. Plasma AB-MarSail. Notations: 1 - spaceship, 2 - plasma ring (circle), 3 - Solar wind, 4 - MagSail thrust, 5 - magnetic force of spaceship.

### 5. Wireless Transferring of Electric Energy in Earth

It is interesting the idea of energy transfer from one Earth continent to another continent without wires. As it is known the resistance of infinity (very large) conducting medium does not depend from distance. That is widely using in communication. The sender and receiver are connected by only one wire, the other wire is Earth. The author offers to use the Earth's ionosphere as the second plasma cable. It is known the Earth has the first ionosphere layer E at altitude about 100 km (Figure 5-6). The concentration of electrons in this layer reaches  $5 \times 10^4$  1/cm<sup>3</sup> in daytime and  $3.1 \times 10^3$  1/cm<sup>3</sup> at night. This layer can be used as a conducting medium for transfer electric energy and communication in any point of the Earth. We need minimum two space 100 km. towers. The cheap optimal inflatable, kinetic, and solid space towers are offered and researched by author in [1]-[4]. Additional innovations are a large inflatable conducting balloon at the end of the tower and big conducting plates in a sea (ocean) that would dramatically decrease the contact resistance of the electric system and conducting medium.

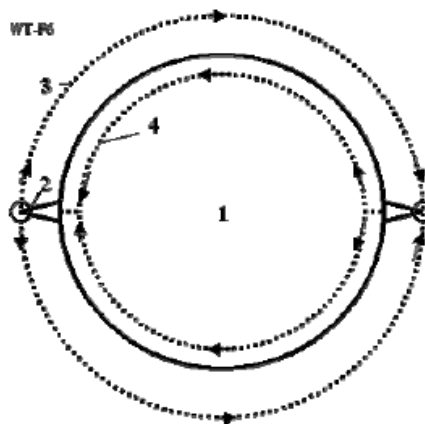


Figure 5-6. Using the ionosphere as conducting medium for transferring a huge electric energy between continents and as a large storage of the electric energy. Notations: 1 - Earth, 2 - space tower about 100 km of height, 3 - conducting E layer of Earth's ionosphere, 4 - back connection through Earth.

## Conclusion

This new revolutionary idea - wireless transferring of electric energy in the hard vacuum of outer space is offered and researched. A rare plasma power cord as electric cable (wire) is used for it. It is shown that a certain minimal electric current creates a compressed force that supports the plasma cable in the compacted form. Large amounts of energy can be transferred hundreds of millions of kilometers by this method. The requisite mass of plasma cable is merely hundreds of grams. It is computed that the macroprojects: transferring of hundreds of kilowatts of energy to Earth's International Space Station, transfer energy to Moon or back, transferring energy to a spaceship at distance of hundreds of millions of kilometers, transfer energy to Mars when it is on the other side of the Sun wirelessly. The transfer of colossal energy from one continent to another continent (for example, Europe to USA and back), using the Earth's ionosphere as a gigantic storage of electric energy, using the plasma ring as huge MagSail for moving of spaceships. It is also shown that electric current in plasma cord can accelerate or slow various kinds of outer space apparatus.

## 6. Simplest AB-Thermonuclear Space Propulsion and Electric Generator\*

The author applies, develops and researches mini-sized Micro- AB Thermonuclear Reactors for space propulsion and space power systems. These small engines directly convert the high speed charged particles produced in the thermonuclear reactor into vehicle thrust or vehicle electricity with maximum efficiency. The simplest AB-thermonuclear propulsion offered allows spaceships to reach speeds of 20,000 - 50,000 km/s (1/6 of light speed) for fuel ratio 0.1 and produces a huge amount of useful electric energy. Offered propulsion system permits flight to any planet of our Solar system in short time and to the nearest non-Sun stars by E-being or intellectual robots during a single human life period.

-----  
 \* See: <http://arxiv.org/ftp/arxiv/papers/0706/0706.2182.pdf> (2006) or [2, Ch.7].

### Description of Innovations

The AB thermonuclear propulsion and electric generator are presented in Figure 6-1. As it is shown in [2] the minimized, or micro-thermonuclear reactor 1 generates high-speed charged particles 2 and neutrons that leave the reactor. The emitted charged particles may be reflected by electrostatic reflector, 4, or adsorbed by a semi-spherical screen 3; the neutrons may only be adsorbed by screen 3.

In *screen* of the AB-thermonuclear reactor (Figure 6-1a) the forward semi-spherical screen 3 adsorbed particles that move forward. The particles, 2, of the back semi-sphere move freely and produce the vehicle's thrust. The forwarded particles may warm one side of the screen (the other side is heat protected) and emit photons that then create additional thrust for the apparatus. That is the *photon* AB-thermonuclear thruster.

In *reflector* AB-thermonuclear reactor (Figure 6-1b) the neutrons fly to space, the charged particles 5 are reflected the electrostatic reflector 4 to the side opposed an apparatus moving and create thrust.

The *screen-reflector* AB-thermonuclear reactor (Figure 6-1c) has the screen and reflector. The *spherical* AB-propulsion-generator (Figure 6-1d) has two nets which stop the charged particles and produced electricity same as in [1, Ch. 17]. Any part 8 of the sphere may be cut-off from voltage and particles 9 can leave the sphere through this section and, thusly, create the thrust. We can change direction of thrust without turning the whole apparatus.

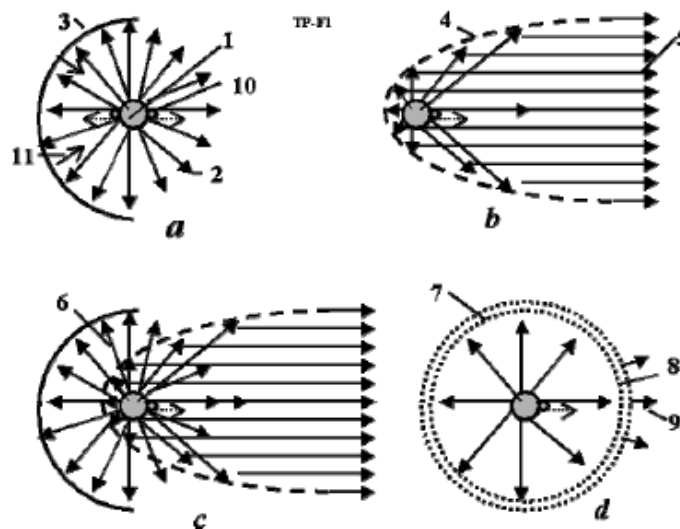


Figure 6-1. Types of the suggested propulsion and power system. (a) screen AB-thermonuclear propulsion and photon AB-thermonuclear propulsion ; (b) (electrostatic) reflector AB-thermonuclear propulsion; (c) screen-reflector AB-thermonuclear propulsion; (d) spherical AB-propulsion-generator. Notations: 1 - micro (mini) AB-thermonuclear reactor [15], 2 - particles (charged particles and neutrons) , 3 - screen for particles, 4 - electrostatic reflector; 5 - charged particles, 6 - neutrons, 7 - spherical net of electric generator, 8 - transparency (for charged particles) part of spherical net, 9 - charged particle are producing the thrust, 10 - electron discharger, 11 - photon radiation.

## Conclusion

The author suggests the simplest maximally efficient thermonuclear AB-propulsion (and electric generators) based in the early offered size-minimized Micro-AB-thermonuclear reactor [2, Part B, Ch.1, p. 223]. These engines directly convert high-speed charged particles produced in thermonuclear reactor into vehicular thrust or onboard vehicle electricity resource. Offered propulsion system allows travel to any of our Solar System's planets in a short time as well as trips to the nearest stars by E-being or intellectual robot in during a single human life [2, Part C].

## 7. Electrostatic Linear Engine and Cable Space AB Launcher\*

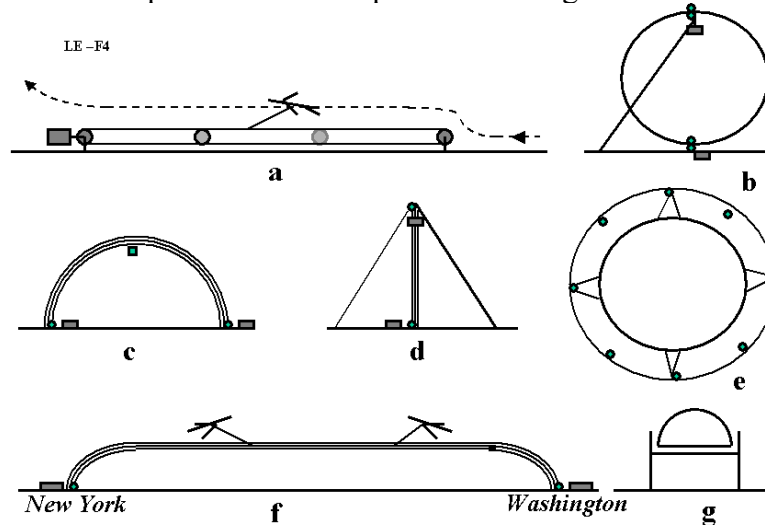
This is suggested a revolutionary new electrostatic engine. This engine can be used as a linear engine (accelerator), a strong space launcher, a high speed delivery system for space elevator, Earth-Moon, Earth-Mars, electrostatic train, levitation, conventional high voltage rotating engine, electrostatic electric generator, weapon, and so on. Author developed theory of this engine application and shows powerful possibility in space, transport and military industry. The projects are computed and show the good potential of the offered new concepts.

\* This work is presented as Bolonkin's paper AIAA-2006-5229 for 42 Joint Propulsion Conference, Sacramento, USA, 9-12 July, 2006. Work is published in Aircraft Engineering and Aerospace Technology: An International Journal, Vol 78, #6, 2006, pp.502-508. See also: <http://arxiv.org/ftp/arxiv/papers/0705/0705.1943.pdf> or [2, Ch.10].

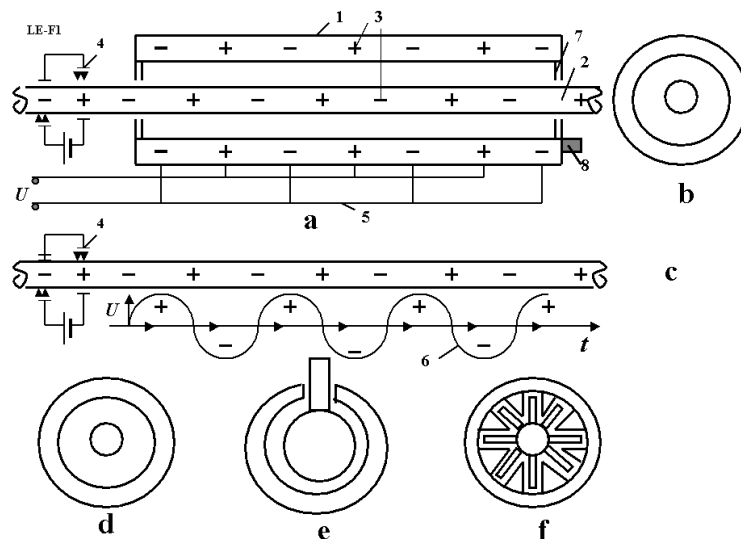
## Description of Electrostatic Linear Engine

The linear electrostatic engine (space accelerator) for launching of space ship [2] p.173 includes the following main parts (Figure 1): stator, thrust cable, charger of cable, high voltage electric alternating current line. As additional devices the engine can have a gas compaction, and vacuum pump.

The cable has a strong core (it keeps tensile stress - thrust) and dielectric cover contained electric charges. The conducting layer is very thin and we neglect its weight. A detailed linear engine (accelerator) for Cable Space Launcher is presented in Figure 7-2.



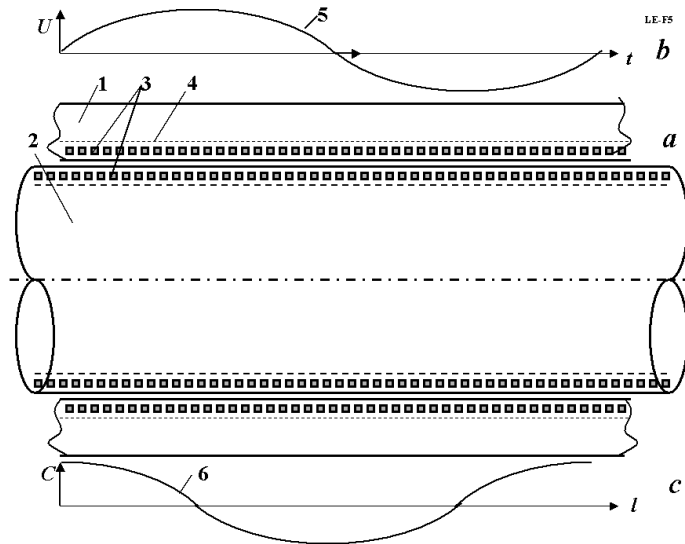
**Figure 7-1.** Installations needing the linear electrostatic engine. (a) Space cable launcher [2]; (b) Circle launcher; (c) Space keeper [1]; (d) Kinetic space tower[1]; (e) Earth round cable space keeper [1]; (f) Cable aviation [1]; (g) Levitation train [1].



**Figure 7-2.** Electrostatic engine (accelerator) for Space Cable Launcher [23 -25]. (a) Engine (side view); (b) Engine (Forward view); (c) Running wave of voltage (charges) moves the charged cable; (d) - (f) Different cross-section areas of engine: (d) - conventional; (e) - for moving aircraft or space ship; (f) - for big thrust. *Notations:* 1 - stator of engine; 2 - thrust cable (rotor of engine); 3 - charges; 4 - recharger; 5 - high voltage line; 6 - alternating current (voltage); 7 - gas compaction; 8 - vacuum pump.

The engine works in the following mode. The cable has a set of stationary positive and negative charges. These charges can be restored if they are relaxed. Outer generator creates a running wave of voltage (charges) along stationary stator. This wave (charges) attracts the opposed charges in rotor (cable) and moves (thrusts) it.

Bottom and top parts of cable (or stator) have small different charge values. This difference creates a vertical electric field which supports the cable in suspended position inside stator non-contact bearing and zero friction. The cable position inside stator is controlled by electronic devices.



**Figure 7-3.** Detail electrostatic engine (accelerator) for Space Cable Launcher. (a) Accelerator, (b) Running voltage wave for stator, (c) Stationary charges into cable. *Notation:* 1 - stator; 2 - mobile rotor (cable); 3 - charges; 4 - dielectric (isolator); 5 - running wave of voltage; 6 - curve of stationary cable charges.  $U$  is voltage,  $C$  is charge. Lagging between voltage wave of stator (b) and charges of mobile cable (c) is 90 degree.

Charges have toroidal form (row of rings) and located inside a good dielectric having high disruptive voltage. The stator toroids have conducting layer which allows changing the charges with high frequency and produces a running high voltage wave. The offered engine creates a large thrust (see computation below), reaches a very high (not limited) variable speed of cable (km/s), to change the moving of cable in opposed direction, to fix a cable in given position. The engine can also to work as high voltage electric generator when cable is braking or moved by mechanical force. The space elevator climber (and many other mobile apparatus) has constant charge, the cable (stator) has running charge. The weight of electric wires is small because the voltage is very high.

## Conclusion

The offered electrostatic engine could find wide application in many fields of technology. That can decrease the launch cost from hundreds to thousands times. The electrostatic engine needs a very high voltage but this voltage is located in small area inside of installations and not dangerous to people. The current technology does not have another way for reaching a high speed except may be rockets. But rockets and rocket launches are very expensive and we do not know ways to decrease the cost of rocket launch thousand times.

## 8. AB Levitrons and their Applications to Earth's Motionless Satellites\*

Author offers the new and distinctly revolutionary method of levitation in artificial magnetic field. It is shown that a very big space station and small satellites may be suspended over the Earth's surface and used as motionless radio-TV translators, telecommunication boosters, absolute geographic position locators, personal and mass entertainment and as planet-observation platforms. Presented here is the theory of big AB artificial magnetic field and levitation in it is generally developed. Computation of three macro-projects: space station at altitude 100 km, TV-communication antenna at height 500 m, and multi-path magnetic highway.

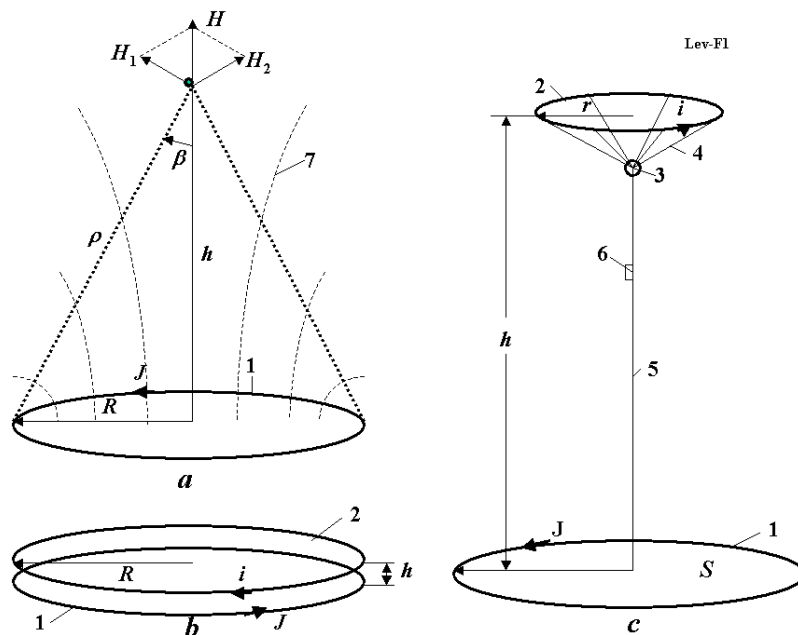
-----  
 \* Presented as Bolonkin's paper to <http://arxiv.org> August, 2007 (search "Bolonkin") or <http://arxiv.org/ftp/arxiv/papers/0708/0708.2489.pdf> or [2, Ch.12].

### Innovations

The AB-Levitron uses two large conductivity rings with very high electric current (fig.8-1). They create intense magnetic fields. Directions of electric current are opposed one to the other and rings are repelling one from another. For obtaining enough force over a long distance, the electric current must be very strong. The current superconductive technology allows us to get very high-density electric current and enough artificial magnetic field in far space.

The superconductivity ring does not spend an electric energy and can work for a long time period, but it requires an integral cooling system because the current superconductivity materials have the critical temperature about 150-180 C.

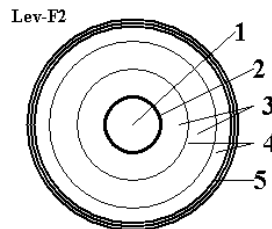
For mobile vehicles the AB-Levitron can have a run-wave of magnetic intensity which can move the vehicle (produce electric current), making it significantly mobile in the traveling medium.



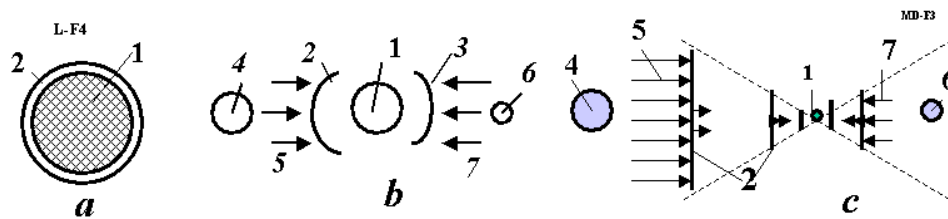
**Figure 8-1.** Explanation of AB-Levitron. (a) Artificial magnetic field; (b) AB-Levitron from two same closed superconductivity rings; (c) AB-Levitron - motionless satellite, space station or communication mast. Notation: 1- ground superconductivity ring; 2 - levitating ring; 3 - suspended stationary satellite (space station, communication equipment, etc.); 4 - suspension cable; 5 - elevator (climber) and electric cable; 6 - elevator cabin; 7 - magnetic lines of ground ring;  $R$  - radius of lower (ground) superconductivity ring;  $r$  - radius of top ring;  $h$  - altitude of top ring;  $H$  - magnetic intensity;  $S$  - ring area.

However, the present computation methods of heat defense are well developed (for example, by liquid nitrogen) and the induced expenses for cooling are small (fig. 8-2).

The ring located in space does not need any conventional cooling—that defense from Sun and Earth radiations is provided by high-reflectivity screens (fig.3). However, that must have parts open to outer space for radiating of its heat and support the maintaining of low ambient temperature. For variable direction of radiation, the mechanical screen defense system may be complex. However, there are thin layers of liquid crystals that permit the automatic control of their energy reflectivity and transparency and the useful application of such liquid crystals making it easier for appropriate space cooling system. This effect is used by new man-made glasses which grow dark in bright solar light.



**Figure 8-2.** Cross-section of superconductivity ring. Notations: 1 - strong tube (internal part used for cooling of ring, external part is used for superconductive layer); 2 - superconductivity layer; 3 - vacuum; 4 - heat impact reduction high-reflectivity screens (roll of thin bright aluminum foil); 5 - protection and heat insulation.



**Figure 8-3.** Methods of cooling (protection from Sun radiation) the superconductivity levitron ring in outer space. (a) Protection the ring by the super-reflectivity mirror [5]. (b) Protection by high-reflectivity screen (mirror) from impinging solar and planetary radiations. (c) Protection by usual multi-screens. Notations: 1 - superconductive wires (ring); 2 - heat protector (super-reflectivity mirror in Fig.3a and a usual mirror in Fig. 3c); 2, 3 – high-reflectivity mirrors (Fig. 3b); 4 - Sun; 5 -Sun radiation, 6 - Earth (planet); 7 - Earth's radiation.

The most important problem of AB-levitron is stability of top ring. The top ring is in equilibrium, but it is out of balance when it is not parallel to the ground ring. Author offers to suspend a load (satellite, space station, equipment, etc) lower then ring plate. In this case, a center of gravity is lower a summary lift force and system become stable.



## Conclusion

We must research and develop these ideas. They may accelerate the technical progress and improve our life-styles. There are no known scientific obstacles in the development and design of the AB-Levitrons, levitation vehicles, high-speed aircraft, spaceship launches, low-altitude stationary telecommunication satellites, cheap space trip to Moon and Mars and other interesting destination-places in outer space.

## 9. Electrostatic Climber for Space Elevator and Launcher\*

Here, the main author details laboratory and library research on the new, and intrinsically prospective, Electrostatic Space Elevator Climber. Based on a new electrostatic linear engine previously offered at the 42nd Joint Propulsion Conference (AIAA-2006-5229) and published in "AEAT", Vol.78, No.6, 2006, pp. 502-508, the electrostatic climber described below can have any speed (and braking), the energy for climber movement is delivered by a light-weight high-voltage line into a Space Elevator-holding cable from Earth-based electricity generator. This electric line can be used for delivery electric energy to a Geosynchronous Space Station. At present, the best solution of the climber problem, announced by NASA, is very problematic.

Shown also, the linear electrostatic engine may be used nowadays as a realistic power space launcher. Two macro-projects illustrate the efficacy of these new devices.

### *Description of Electrostatic Linear Climber and Launcher*

The linear electrostatic engine [2, Ch.10], climber, for Space Elevator includes the following main parts (Figure 9-1): plate (type) stator 1 (special cable of Space elevator), cylinders 3 inside having conducting layer (or net) (cylinder may be vacuum or inflatable film), conducting layer insulator, chargers (switches 6) of cable cylinders, high-voltage electric current line 6, linear rotor 7.

Linear rotor has permanent charged cylinder 4. As additional devices, the engine can have a gas-pressurizing capability and a vacuum pump [1-2].

The cable (stator) has a strong cover 2 (it keeps tensile stress - thrust/braking) and variable cylindrical charges contained dielectric cover (insulator). The conducting layer is very thin and we neglect its weight. Cylinders of film are also very light-weight. The charges can be connected to high-voltage electric lines 6 that are linked to a high-voltage device (electric generator) located on the ground.

The electrostatic engine works in the following mode. The rotor has a stationary positive charge. The cable has the variable positive and negative charges. These charges can be received by connection to the positive or negative high-voltage electric line located in cable (in stator). When positive rotor charge is located over given stator cylinder this cylinder connected by switch to positive electric lines and cylinder is charged positive charge but simultaneously the next stator cylinder is charged by negative charge. As result the permanent positive rotor charge repels from given positive stator charge and attracts to the next negative stator charge. This force moves linear rotor (driver). When positive rotor charge reaches a position over the negative stator charge, that charge re-charges to positive charge and next cylinder is connected to the negative electric line and then the whole cycle is repeated. To increase its efficiency, the positive and negative stator charges, before the next cycle, can run down

---

\* This work is presented as paper AIAA-2007-5838 for 43 Joint Propulsion Conference, Cincinnati, Ohio, USA, 9 -11 July, 2007. See also: <http://arxiv.org/ftp/arxiv/papers/0705/0705.1943.pdf> or [3, Ch.4].

through a special device, and their energy is returned to the electric line. It is noteworthy that the linear electrostatic engine can have very high efficiency!

Earth-constant potential generator creates a running single wave of charges along the stationary stator. This wave (charges) attracts (repel) the opposed (same) charges in rotor (linear driver) and moves (thrust or brake use) climber.

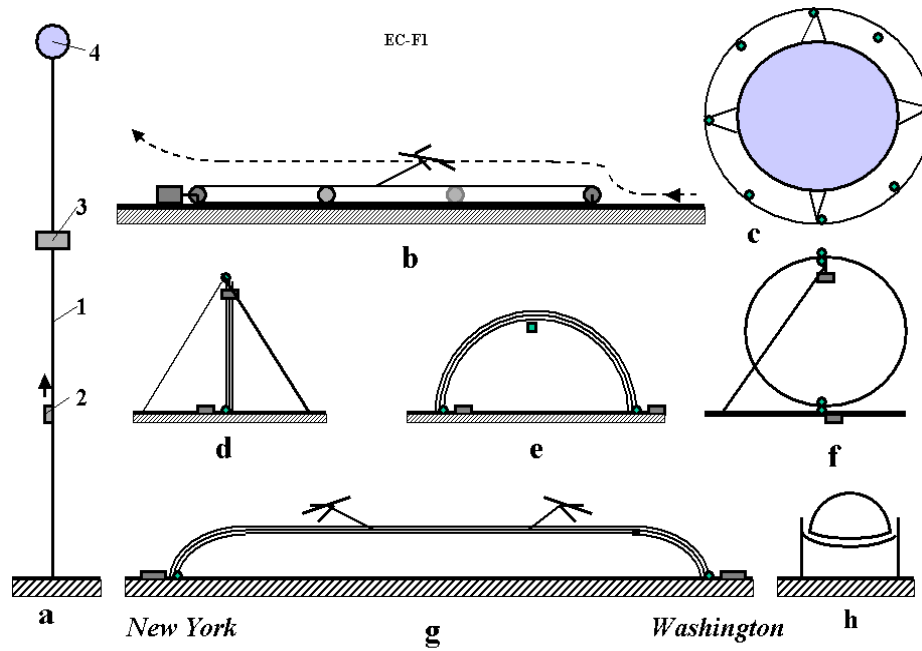


Figure 9-1. Installations needing the linear electrostatic engine. (a) Space elevator [36]. Notation: 1 - space elevator, 2 - climber, 3 - geosynchronous space station, 4 - balancer of space elevator. (b) Space cable launcher [3]; (b) Circle launcher [3]; (c) Earth round cable space keeper [38]; (d) Kinetic space tower [3]; (e - f) Space keeper [3]; (g) (f) Cable aviation [3]; (g) Levitation train [2-3].

The space launcher works same (Figure 9-2d, 2e). That has a stationary stator and mobile rotor (driver). The stationary stator (monorail) located upon the Earth's surface below the atmosphere. Driver is connected to space-aircraft and accelerates the aircraft to a needed speed (8 km/s and more) [2]. For increasing a thrust, the driver of the space launcher can have some charges (Figure 9-2d) separated by enough neutral non-charged stator cylinders.

Bottom and topmost parts of cable (or stator) have small different charge values. This difference creates a vertical electric field which supports the driver in its suspended position about the stator, non-contact bearing and zero friction. The driver position about the stator is controlled by electronic devices.

Charges have cylindrical form (row of cylinders), and are located within a good dielectric having high disruptive voltage. The cylinders have conducting layer which allows changing the charges with high frequency and produces a running high-voltage wave of charges. The engine creates a large thrust (see computation below), reaches a very high (practically speaking, virtually unlimited) variable speed of driver (km/s), to change the moving of driver in opposed direction, to fix a driver in selected given position. The electrostatic engine can also operate as a high-voltage electric generator when the climber (a cabin-style spaceship) is braking or is moved by some controlled mechanical force. The Space Elevator climber (and many other mobile apparatuses) has a constant charge; the cable (stator) has a running charge. The weight of electric wires is small, almost insignificant, because the voltage is very high.

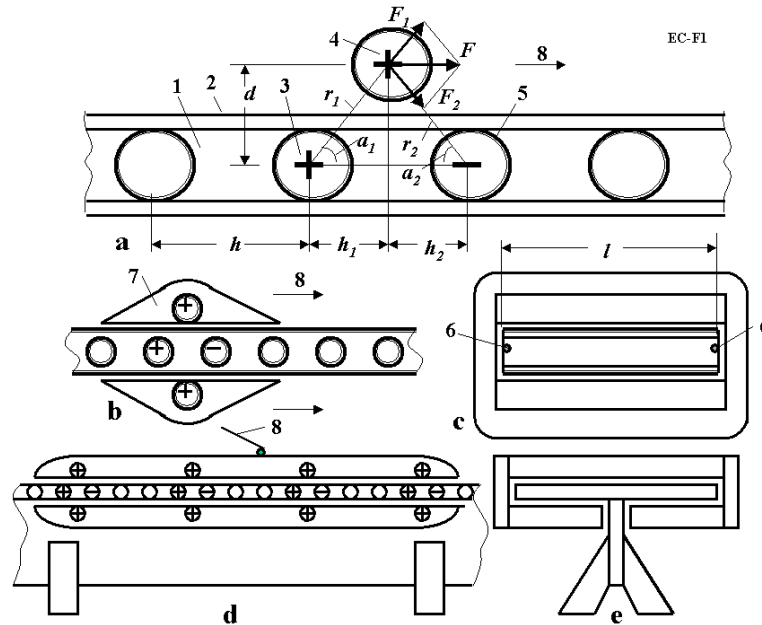


Figure 9-2. Electrostatic linear engine (accelerator) for Space Elevator and Space Launcher [23 -25, 40]. (a) Explanation of force in electrostatic engine; (b) Two cylindrical electrostatic engines for Space Elevator (here, a side view); (c) Two cylindrical electrostatic engine for Space Elevator (forward view); (d) Eight cylindrical electrostatic engine for Space Launcher (side view); (e) Eight cylindrical electrostatic engine for Space Launcher (forward view).

Notations: 1 - plate cable of Space Elevator with inserted variable cylindrical charges; 2 - part of cable-bearing tensile stress; 3 - insulated variable charging cylinder of stator; 4 - insulated permanent charging cylinder of rotor; 6 – high-voltage wires connected with Earth's generator and switch; 7 - mobile part of electrostatic linear engine; 8 - cable to space aircraft.

## Conclusion

Presently, the suggested space climber is the single immediately buildable high-efficiency transport system for a space elevator. The electromagnetic beam transfer energy is very complex, expensive and has very low efficiency, especially at a long-distance from divergence of electromagnetic beam. The laser has similar operational disadvantages. The conventional electric line, equipped with conventional electric motor, is very heavy and decidedly unacceptable for outer space.

The offered electrostatic engine could find wide application in many fields of technology. It can drastically decrease the monetary costs of launch by hundreds to thousands of times. The electrostatic engine needs a very high-voltage but this voltage, however, is located in a small area inside of installations, and is not particularly dangerous to person living or working nearby. Currently used technology does not have any other way for reaching a high speed except by the use of rockets. But crewed or un-crewed rockets, and rocket launches for expensive-to-maintain-and-operate Earth bases, are very expensive and space businesses do not know ways to cut the cost of rocket launch by hundreds to thousands of times.

## 10. AB-Space Propulsion\*

On 4 January 2007 the article “Wireless Transfer of Electricity in Outer Space” in <http://arxiv.org> was published wherein was offered and researched a new revolutionary method of

\* Presented in <http://arxiv.org> of Cornell University (1 March, 2008). <http://arxiv.org/ftp/arxiv/papers/0803/0803.0089.pdf>, or [3] Ch.10.

transferring electric energy in space. In next article (see <http://arxiv.org>) was developed the theory of new engine.

That Chapter describes a new engine which produces a large thrust without throwing away large amounts of reaction mass (unlike the conventional rocket engine). A sample computed project shows the big possibilities opened by this new “AB-Space Engine”. The AB-Space Engine gets the energy from ground-mounted power; a planet’s electric station can transfer electricity up to 1000 millions (and more) of kilometers by plasma wires. Author shows that AB-Space Engine can produce thrust of 10 tons (and more). That can accelerate a spaceship to some thousands of kilometers/second. AB-Space Engine has a staggering specific impulse owing to the very small mass expended. The AB-Space Engine reacts not by expulsion of its own mass (unlike rocket engine) but against the mass of its planet of origin (located perhaps a thousand of millions of kilometers away) through the magnetic field of it’s plasma cable. For creating this plasma cable the AB-Space Engine spends only some kg of hydrogen.

### ***Offered Innovations and Brief Descriptions***

1. Transfer of electricity by plasma cable. The author offers a series of innovations that may solve the many macro-problems of transportation, energy and thrust in space. Below are some of them.

1. Transfer of electrical energy in outer space using a conductive cord from plasma. Author has solved the main problem - how to keep the plasma cord from dissipation, and in compressed form. He has developed the theory of space electric transference, made computations that show the possibility of realization for these ideas with existing technology. The electric energy may be transferred for hundreds millions of kilometers in space (including Moon and Mars) [1].
2. Method of construction of space electric lines and electric devices.
3. Method of utilization and tapping of the plasma cable electric energy.
4. Two methods of converting the electric energy to impulse (thrust) motion of a spacecraft (these two means are utilization of the magnetic field and of the kinetic energy of ions and electrons of the electric current).
5. Design of a triple electrostatic mirror (plasma reflector), which can reflect the plasma flow [1].

Below are some succinct descriptions of some constructions made possible by these revolutionary macro-engineering ideas.

*1. Transferring electric energy in Space.* The electric source (generator, station) is connected to the distant location in space by two artificially generated rarefied plasma cables (Figure 10-1a). These cables can be created by a plasma beam [1, 2] sent from the Moon, Earth mounted super high tower, or from a space station in low Earth orbit, or a local base at the target location. If the plasma beam is sent remotely from the Earth, a local reflector station is required at the target site or at a third location to turn the circuit back toward its’ starting point and closure.

The plasma cable, in radial direction, may also be constructed of ultra-cold plasma. The plasma cable is self-supported in cable form by the magnetic field created by the electric current going through the plasma cable. The axial electric current produces an contracting magnetic pressure opposed to an expansive gas dynamic plasma pressure (the well-known theta-pinch effect)(Figure 10-2b). The plasma has a good conductivity (equal to that of silver and more) and the plasma cable can have a very big cross-section area (up to thousands of square meters cross-section). The plasma

conductivity does not depend on its' density. That way the plasma cable has no large resistance although the length of plasma cable is hundreds of millions of kilometers. The needed minimum electric current is derived from parameters of a plasma cable researched in the theoretical section of this article.

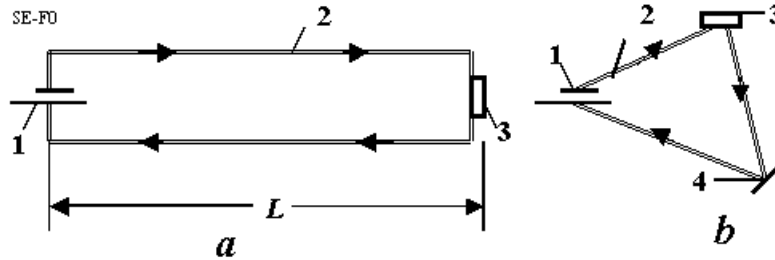


Figure 10-1. Long distance plasma transfer electric energy and thrust in outer space. *a* - plasma transfer with parallel plasma cable, *b* - plasma transfer with triangular (three-wire) plasma cable. *Notations*: 1 - current source (generator), 2 - plasma wire (cable), 3 - spaceship, orbital station or other energy destinations, 4 - plasma reflector located at planet, asteroid or space station.

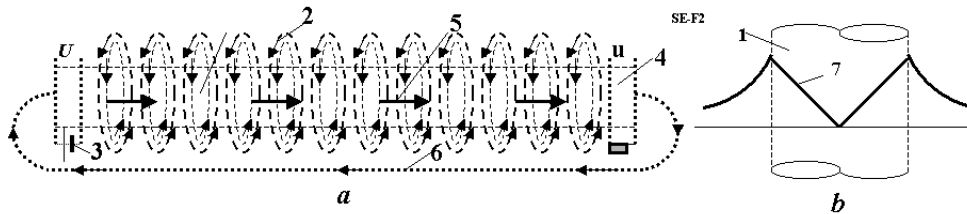


Figure 10-2. *a*. A plasma cable supported by its' own magnetic field, *b*. Magnetic intensity into and out of plasma cable. *Notations*: 1 -plasma cable, 2 - compressing magnetic field, 3 - electric source, 4 - electric receiver, 5 - electric current, 6 - back plasma line; 7 - magnetic intensity into and out of plasma cable.

The parallel cables having opposed currents repel each other (Figure 10-2a)(by magnetic force). This force may be balanced by attractive electric force if we charge the cables by electric charges (see theoretical section). They also can be separated by a special plasma reflector as it shown in figures 10-2b. The electric line can be created and exist independently. The spaceship connects to this line at a suitable point. By altering the diameter and direction of the plasma cable we can supply energy to a spacecraft. Though we must supply energy to accelerate the spacecraft we can also regenerate energy by its braking activity. At any time, the spaceship can disconnect from the line and can exist without line support (propulsion, electricity, etc). The apparatus can hook up to or disconnect from the plasma cable at will. But breaking (loss of continuity) of the plasma cable itself destroys the plasma cable line to the remote location! We must have additional (parallel) plasma lines and apparatus must disconnect from a damaged or occulted (for example on the far side of a remote planet) plasma line and connect to another line to keep the connection in existence. The same situation is true in a conventional electric net. The apparatus can also restore the damaged part of plasma line by own injected plasma, but the time for repairing is limited (by tens of minutes or a few hours). The original station can also to send the plasma beam which connects the ends of damaged part of the line.

The electric tension (voltage) in a plasma cable is between two ends (for example, as cathode- anode) of the conductor in the issuing electric station (electric generator) [1-4]. The plasma cable current has two flows: Electron (negative) flow and opposed ions (positive) flow in the same cable.

These flows create an electric current. (In metal we have only electron flow, in liquid electrolytes we have ions flowing).

The author offers methods (for extraction and inserting) of energy from the plasma electric cable (Figure 3) by customer (spacecraft, other energy destination or end user).

The double net can accelerate the charged particles and insert energy into plasma cable (fig, 3a) or brakes charged particles and extract energy from electric current (figure 3b). In the first case the two nets create the straight electrostatic field, in the second case the two nets create the opposed electrostatic field in plasma cable (resistance in the electric cable [1- 4]) (figures 10-2, 10-3c). This apparatus resistance utilizes the electric energy for the spaceship or space station. In the second case the charged particles may be collected into a set of thin films and emit (after utilization in apparatus) back into continued plasma cable (see [1- 4]).

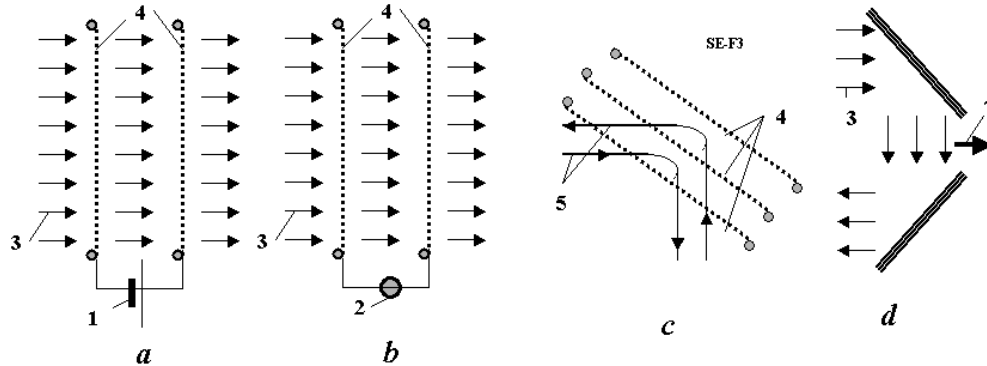


Figure 10-3. Getting and inserting in (off) plasma cable the energy and turning of plasma cable. *a* – inserting electric energy into plasma cable by means of two thin conducting nets or films; *b* - getting the energy from plasma cable by means of two thin conducting nets or films; *c* – offered triple net plasma reflector; *d* – double triple net plasma reflectors - the simplest AB thruster. *Notations*: 1 - spaceship or space station, 2 – receiver of energy, 3 - plasma cable, 4 - electrostatic nets, 5 – two opposed flows of charged plasma particles (negative and positive: electron and ions), 7 – thrust of AB-Space Engine.

Figure 10-3c presents the plasma beam reflector [1-4]. That has three charged nets. The first and second nets reflect (for example) positive particles, the second and third nets reflected the particles having an opposed charge.

Figure 10-4 shows the different design the plasma cable in space.

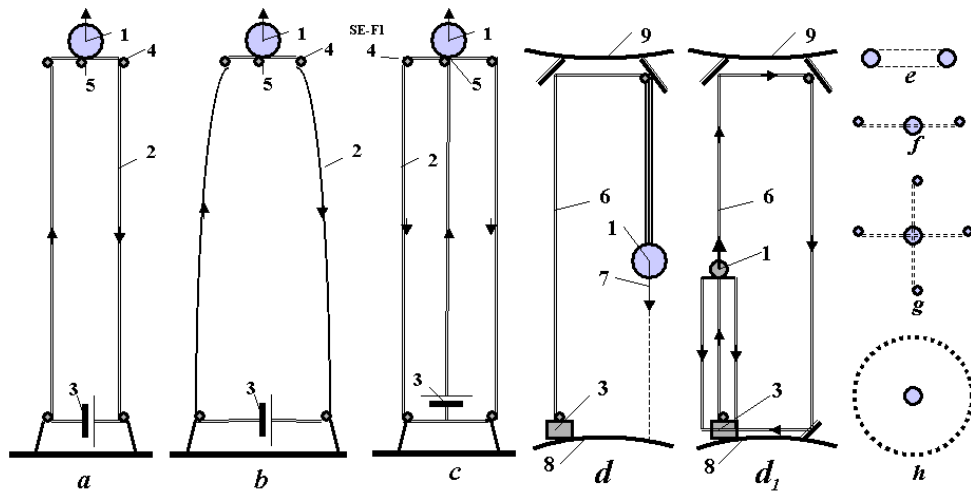


Figure 10-4. Transfer electricity and thrust by AB-Space Engine: *a*. Two plasma parallel cables; *b*. Curved cable; *c*. Plasma multi-cables; *d*. Transfer of back thrust through planet or asteroid; *d*<sub>1</sub>. Using of ready plasma line; *e* – *h*. Forms of straight and back plasma cables (cross-sections of cables). *Notations*: 1 – Space ship; 2 – plasma cable; 3 – source electricity; 4 - plasma injector; 5 – user of energy; 6 – double plasma line; 7 - thrust; 8 – Earth; 9 – planet or asteroid.

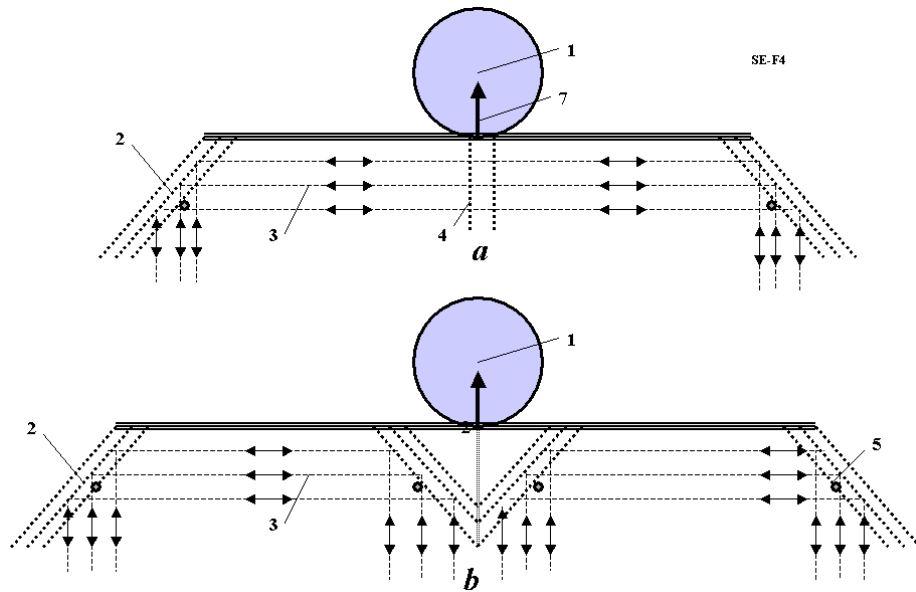


Figure 10-5. Some versions of AB-Space Engine (thruster). a. two cable AB-Space Engine; b. Three cable AB-Space Engine. Notations; 1 – space ship; 2 – offered special (three nets) electrostatic reflector; 3 – plasma cable; 4 – receiver or source of energy; 5 – injector of plasma, 7 – thrust.

Figure 10-4a shows two plasma parallel cables. Figure 4b two shows plasma parallel cables of a curved form of line. Figure 10-4c presents three plasma parallel cables, one to space ship and two for back (return) current. Figure 10-4d shows the transfer of the reverse impulse (or braking) thrust to space ship through planet or asteroid. Figures 10-5e-h shows the different forms of the straight and back plasma cables (cross-section of cables).

2. *AB-Space Engine*. The offered simplest AB-Space Engine is shown in Figure 10-4d and more details in Figures 10-5, 6. That includes two new triple electrostatic reflectors 2 which turn the plasma cables' (flow), (electric current 3) in back direction. The engine may also contain (optional) the plasma injectors 5 and electric generator (user) 4.

As feed material for the plasma may be used hydrogen gas, as plasma reflector may be used three conductivity nets connected to voltage sources, as generator - the double conductivity nets located into plasma flow and connected to voltage sources or users.

The other design of AB-Space Engine is shown in figure 10-6b. Here the central plasma flow divides in two side flows which go back to the electric station.

The AB-Space Engine works as follows. The electric current (voltage) produced by electric station (that may be located far from AB-Space Engine, for example, in orbit around the Earth or mounted on the Moon, Phobos or another space body) transfers by plasma cable to the AB-Space Engine. The power of the electric current in the plasma produces the power plasma flow of electrons and ions. The engine turns back the plasma flow (electric current) and returns it to the source electric station by the other plasma cable. The magnetic and centrifugal forces appear at the point of turning from outgoing to ingoing plasma paths place and create the thrust which can be used for movement (acceleration, braking) the space apparatus (or conventional vehicle or projectile).

Long-time readers of proposed space drive papers may suspect something fishy here. Don't worry: The AB-Space Engine doesn't violate Newton's third law of action and reaction. The AB-Space Engine reacts against the (planet or station mounted) electric station which may be located hundreds of millions of kilometers away! No other engine has the same capability.



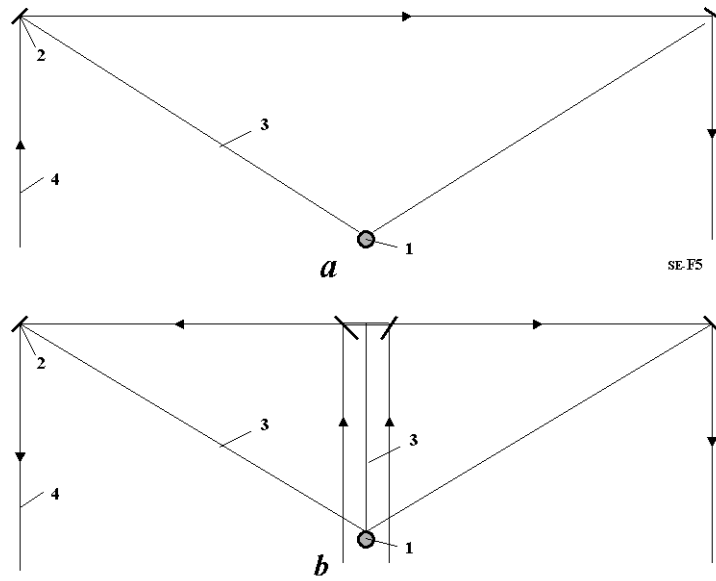


Figure 10-6. Some versions of widely (many km) AB-Space Engine (thruster). a. two cable AB-Space Engine; b. Three cable AB-Space Engine. Notations; 1 – space ship; 2 – offered special (three nets) electrostatic reflector; 3 – thin space cable connected the ship and reflector; 4 – plasma cable.

Your attention is also directed to the following differences between a railgun and an AB-Space Engine:

- 1) The railgun uses SOLID physical rails for delivery the electric current to conductivity projectile. These are easily damaged by huge electric current. The AB-Space Engine uses flexible plasma cables which can self-repair.
- 2) The railgun uses the rails which are of fixed construction (unalterable) and a spacecraft so launched can move solely in the rail direction. The AB-Space Engine creates the plasma cable in the course of apparatus movement and can select and change the apparatus' future direction.
- 3) Even a theoretical railgun girdling the globe of the Moon in vacuum (for star probe launch) would have a possible length of only some kilometers (as any solid construction). The plasma electric line (used by AB-Space Engine) can have a length (an acceleration path) of millions of kilometers (and thus may someday power manned craft on missions to near interplanetary space).

## **Discussion**

### **Advantages of AB-engine**

- 1) The offered AB-Space Engine is very light, simple, safe, and reliable with comparison to any likely nuclear engine.
- 2) The AB-Space Engine has a gigantic 'virtual specific impulse', being more capable of realistic operation in a projectable near-future environment, than virtually any proposed means of thermonuclear or light-propulsion scheme the author is aware of.
- 3) The AB-Space Engine can accelerate a near-term space apparatus to very high speed (approaching light speed). At present time this is the single real method to be able to approach this 'ultimate' velocity.

- 4) At least part of the needed injected plasma cable mass and nearly all of the energy needed (and the cooling facilities needed to maintain that energy supply) can be from the planet-bound energy-supplying station, further improving the on-board ship 'mass ratio'.
- 5) The AB-Space Engine can use far cheaper energy from a planet-bound electric station.

The offered ideas and innovations may create a jump in space and energy industries. Author has made initial base researches that conclusively show the big possibilities offered by the methods and installations proposed. Further research and testing are necessary. Those tests are not expensive. As that is in science, the obstacles can slow, even stop, applications of these revolutionary innovations. For example, the plasma cable may be unstable. The instability mega-problem of a plasma cable was found in tokamak R&D, but it is successfully solved at the present time. The same method (rotation of plasma cable) can be applied in our case.

The other problem is production of the plasma cable in Earth's atmosphere. This problem may be sidestepped by operations from a suitably high super-stratospheric tower such as outlined in others of the author's works, or is no problem at all if the electric station of the plasma cables' origin is located on the Moon [3].

The author has ideas on how to solve this problem with today's technologies and to use the readily available electric stations found on this planet Earth. Inquiries from serious parties are invited.

## **Summary**

This new revolutionary idea – The AB-Space Engine and wireless transferring of electric energy in the hard vacuum of outer space – is offered and researched. A rarefied plasma power cord in the function of electric cable (wire) is used for it. It is shown that a certain minimal electric current creates a compression force that supports and maintains the plasma cable in its compacted form. Large amounts of energy can be transferred hundreds of millions of kilometers by this method. The requisite mass of plasma cable is merely hundreds of grams (some kg). A sample macroproject is computed: An AB-Space Engine having thrust = 10 tons. It is also shown that electric current in plasma cord can accelerate or slow various kinds of outer space apparatus.

## **11. Wireless Transfer of Electricity from Continent to Continent\***

Author offers collections from his previous research of the revolutionary new ideas: wireless transferring electric energy in long distance – from one continent to other continent through Earth ionosphere and storage the electric energy into ionosphere. Early he also offered the electronic tubes as the method of transportation of electricity into outer space and the electrostatic space 100 km towers for connection to Earth ionosphere.

Early it is offered connection to Earth ionosphere by 100 km solid or inflatable towers. There are difficult for current technology. In given work the research this connection by thin plastic tubes supported in atmosphere by electron gas and electrostatic force. Building this system is cheap and easy for current technology.

The computed project allows to estimate the possibility of the suggested method.

---

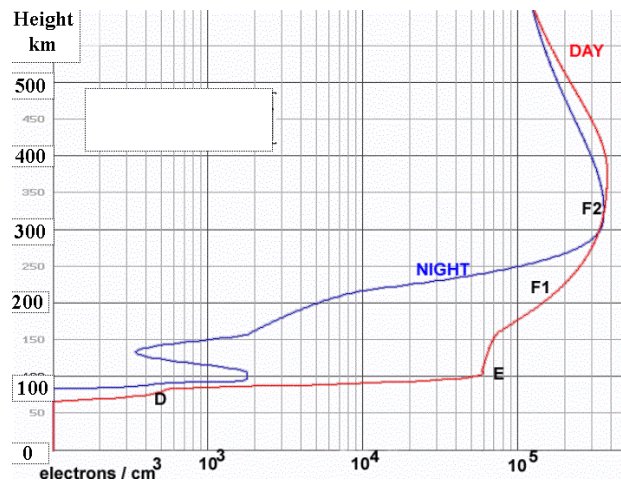
\*See: <http://www.scribd.com/doc/42721638/> or [4].

### **Wireless transferring of electric energy in Earth.**

It is interesting the idea of energy transfer from one Earth continent to another continent without

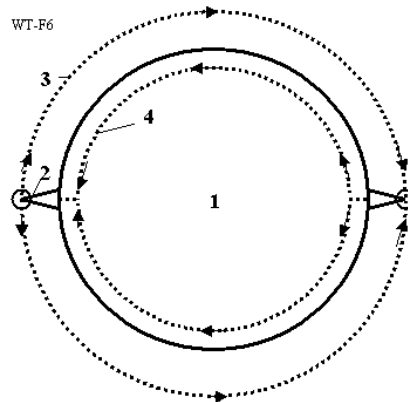
wires. As it is known the resistance of infinity (very large) conducting medium does not depend from distance. That is widely using in communication. The sender and receiver are connected by only one wire, the other wire is Earth. The author offers to use the Earth's ionosphere as the second plasma cable. It is known the Earth has the first ionosphere layer *E* at altitude about 100 km (Fig. 1). The concentration of electrons in this layer reaches  $5 \times 10^4$  1/cm<sup>3</sup> in daytime and  $3.1 \times 10^3$  1/cm<sup>3</sup> at night (Fig. 11-1). This layer can be used as a conducting medium for transfer electric energy and communication in any point of the Earth. We need minimum two space 100 km. towers (Fig. 11-2). The cheap optimal inflatable, kinetic, and solid space towers are offered and researched by author in [4]. Additional innovations are a large inflatable conducting balloon at the end of the tower and big conducting plates in a sea (ocean) that would dramatically decrease the contact resistance of the electric system and conducting medium.

Theory and computation of these ideas are presented in Macroprojects section [4].



**Fig. 11-1.** Consentration/cm<sup>3</sup> of electrons (= ions) in Earth's atmosphere in the day and night time in the D, E, F1, and F2 layers of ionosphere.

However the solid 100 km space towers are very expensive. Main innovation in this work is connection to ionosphere by cheap film tube filled by electron gas.



**Fig. 11-2.** Using the ionosphere as conducting medium for transferring a huge electric energy between continents and as a large storage of the electric energy. Notations: 1 - Earth, 2 - space tower (or electron tube) about 100 km of height, 3 - conducting *E* layer of Earth's ionosphere, 4 - back connection through Earth.

## Electronic tubes

The author's first innovations in electrostatic applications were developed in 1982-1983 [1]-[4], [3, p.497]. Later the series articles of this topic were published in [2, Ch.6]. In particular, in the work [4-5] was developed theory of electronic gas and its application to building (without space flight!) inflatable electrostatic space tower up to the stationary orbit of Earth's satellite (GEO) [2, Ch.11].

In given work this theory applied to special inflatable electronic tubes made from thin insulator film. It is shown the charged tube filled by electron gas is electrically neutral, that can has a high internal pressure of the electron gas.

The main property of AB electronic tube is a very low electric resistance because electrons have small friction on tube wall. (In conventional solid (metal) conductors, the electrons strike against the immobile ions located in the full volume of the conductor.). The abnormally low electric resistance was found along the lateral axis only in nanotubes (they have a tube structure!). In theory, metallic nanotubes can have an electric current density (along the axis) more than 1,000 times greater than metals such as silver and copper. Nanotubes have excellent heat conductivity along axis up 6000 W/m·K. Copper, by contrast, has only 385 W/m·K. The electronic tubes explain why there is this effect. Nanotubes have the tube structure and electrons can free move along axis (they have only a friction on a tube wall).

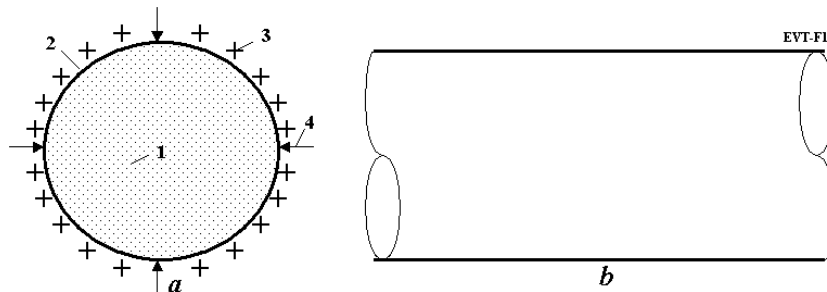
More over, the moving electrons produce the magnetic field. The author shows - this magnetic field presses against the electron gas. When this magnetic pressure equals the electrostatic pressure, the electron gas may not remain in contact with the tube walls and their friction losses. The electron tube effectively becomes a superconductor for any surrounding temperature, even higher than room temperature! Author derives conditions for it and shows how we can significantly decrease the electric resistance.

### Description, Innovations, and Applications of Electronic tubes.

An electronic AB-Tube is a tube filled by electron gas (fig.11-3). Electron gas is the lightest gas known in nature, far lighter than hydrogen. Therefore, tubes filled with this gas have the maximum possible lift force in atmosphere (equal essentially to the lift force of vacuum). The applications of electron gas are based on one little-known fact – the electrons located within a cylindrical tube having a positively charged cover (envelope) are in neutral-charge conditions – the total attractive force of the positive envelope plus negative contents equals zero. That means the electrons do not adhere to positive charged tube cover. They will freely fly into an AB-Tube. It is known, if the Earth (or other planet) would have, despite the massive pressures there, an empty space in Earth's very core, any matter in this (hypothetical!) cavity would be in a state of weightlessness (free fall). All around, attractions balance, leaving no vector 'down'.

Analogously, that means the AB-Tube is a conductor of electricity. Under electric tension (voltage) the electrons will collectively move without internal friction, with no vector 'down' to the walls, where friction might lie. In contrast to movement of electrons into metal (where moving electrons impact against a motionless ion grate). In the AB-Tube we have only electron friction about the tube wall. This friction is significantly less than the friction electrons would experience against ionic structures—and therefore so is the electrical resistance.

When the density of electron gas equals  $n = 1.65 \times 10^{16} / r \text{ 1/m}^3$  (where  $r$  is radius of tube, m), the electron gas has pressure equals atmospheric pressure 1 atm (see research below). In this case the tube cover may be a very thin—though well-sealed-- insulator film. The outer surface of this film is charged positively by static charges equal the electron charges and AB-Tube is thus an electrically neutral body.

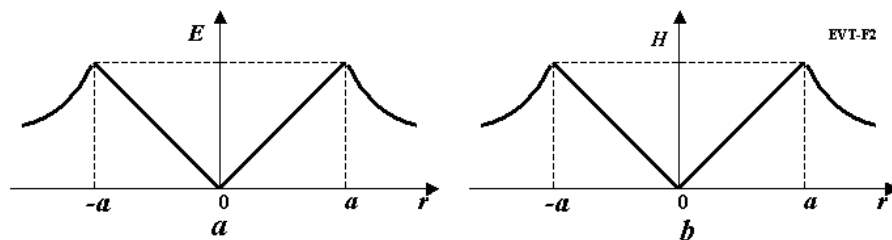


**Fig. 11-3.** Electronic vacuum AB-Tube. *a)* Cross-section of tube. *b)* Side view. *Notation:* 1 – Internal part of tube filled by free electrons; 2 – insulator envelope of tube; 3 – positive charges on the outer surface of envelope (over this may be an additional film-insulator); 4 – atmospheric pressure.

Moreover, when electrons move into the AB-Tube, the electric current produces a magnetic field (fig. 11-4). This magnetic field compresses the electron cord and decreases the contact (and friction, electric resistance) electrons to tube walls. In the theoretical section is received a simple relation between the electric current and linear tube charge when the magnetic pressure equals to electron gas pressure  $i = c\tau$  (where  $i$  is electric current, A;  $c = 3 \times 10^8$  m/s – is the light speed;  $\tau$  is tube linear electric charge, C/m). In this case the electron friction equals zero and AB-Tube becomes **superconductive at any outer temperature**. Unfortunately, this condition requests the electron speed equals the light speed. It is, however, no problem to set the electron speed very close to light speed. That means we can make the electric conductivity of AB-Tubes very close to superconductivity almost regardless of the outer temperature.

### Summary

This new revolutionary idea - wireless transferring of electric energy in long distance through the ionosphere or by the electronic tubes is offered and researched. A rare plasma power cord as electric cable (wire) is used for it. It is shown that a certain minimal electric currency creates a compressed force that supports the plasma cable in the compacted form. Large amounts of energy can be transferred many thousands of kilometers by this method. The requisite mass of plasma cable is merely hundreds of grams. It is computed that the macroproject: The transfer of colossal energy from one continent to another continent (for example, Europe to USA and back), using the Earth's ionosphere as a gigantic storage of electric energy.



**Fig. 11-4.** Electrostatic and magnetic intensity into AB-Tube. *a)* Electrostatic intensity (pressure) via tube radius. *b)* Magnetic intensity (pressure) from electric current versus tube radius.

## 12. Magnetic Space Launcher\*

A method and facilities for delivering payload and people into outer space are presented. This method uses, in general, engines located on a planetary surface. The installation consists of a space

apparatus, power drive stations, which include a flywheel accumulator (for storage) of energy, a variable reducer, a powerful homopolar electric generator and electric rails. The drive stations accelerate the apparatus up to hypersonic speed.

The estimations and computations show the possibility of making this project a reality in a short period of time (for payloads which can tolerate high  $g$ -forces). The launch will be very cheap at a projected cost of \$3 - \$5 per pound. The authors developed a theory of this type of the launcher.

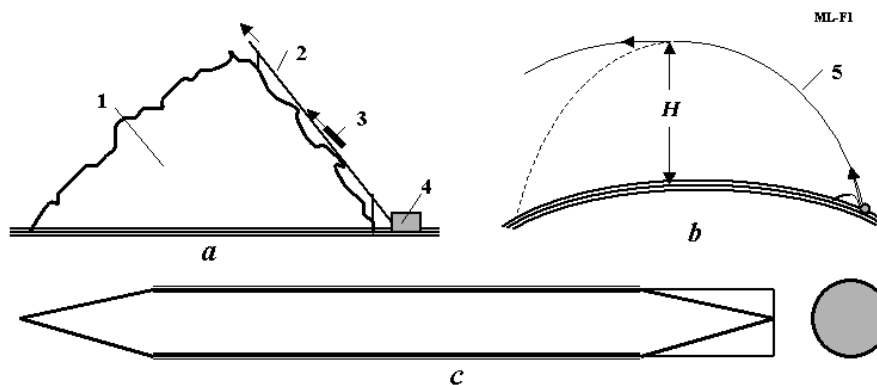
-----  
 \*Presented as paper AIAA-2009-5261 to 45<sup>th</sup> AIAA Joint Propulsion Conference, 2-5 August 2009, Denver, CO, USA. See also <http://www.scribd.com/doc/24051286/> or [4].

## Description of Suggested Launcher

**Brief Description.** The installation includes (see notations in Figs. 12-1, 12-2): a gun, two electric rails 2, a space apparatus 3, and a drive station 4 (fig. 12-1). The drive station includes: a homopolar electric generator 1 (fig. 12-2), a variable reducer 3, a fly-wheel energy storage 5, an engine 6, and master drive clutches 2, 4, 6.

The system works in the following way:

The engine 7 accelerates the flywheel 5 to maximum safe rotation speed. At launch time, the fly wheel connects through the variable reducer 3 to the homopolar electric generator 1 which produces a high-amperage current. The gas gun takes a shot and accelerates the space apparatus “c” (fig. 12-3) up to the speed of 1500 – 2000 m/s. The apparatus leaves the gun and gains further motion on the rails 2 (fig. 12-3) where its body turns on the heavy electric current from the electric generator. The magnetic force of the electric rails accelerates the space apparatus up to speeds of 8000 m/s. (or more). The initial acceleration with a gas gun can decrease the size and cost of the installation when the final speed is not high. The gas gun cannot produce a projectile speed of more than about 2000 m/s. The railgun does not have this limit, but produces some engineering problems such as the required short (pulsed) gigantic surge of electric power, sliding contacts for some millions of amperes current, storage of energy, etc.



**Fig. 12-1.** Magnetic Launcher. (a) Side view; (b) Trajectory of space apparatus; (c) Hypersonic apparatus. Notations: 1 – hill (side view); 2 – railing; 3 – shell; 4 – drive station; 5 – space trajectory.

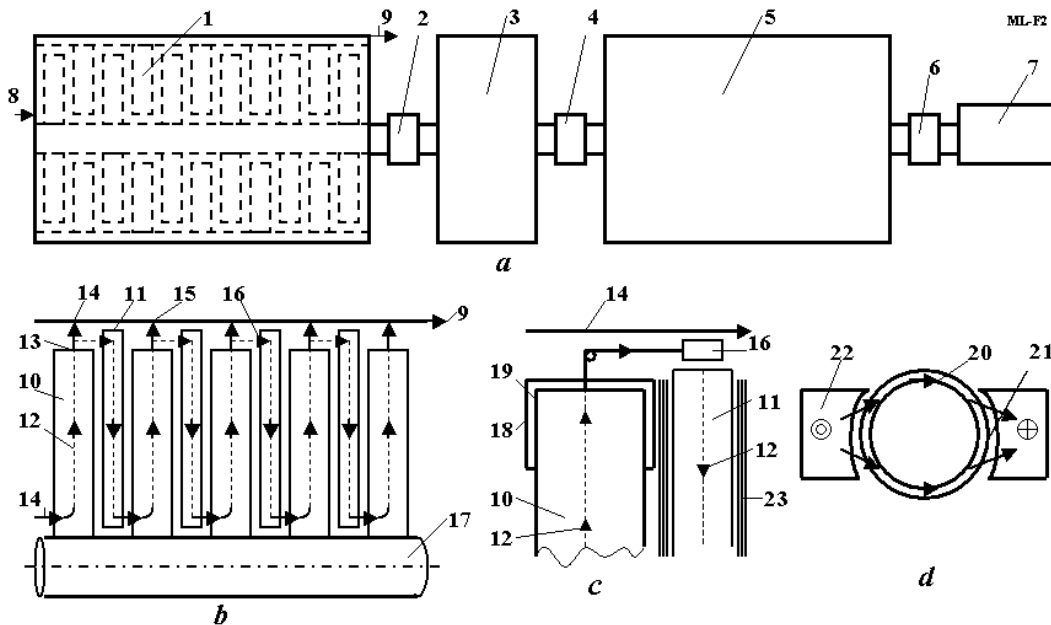
The current condensers have a small electric capacity 0.002 MJ/kg ([3, p.465]). We would need about  $10^{10}$  J energy and 5000 tons of these expensive condensers. The fly-wheels made of cheap artificial fiber have capacity about 0.5 MJ/kg ([3, p.464]). The need mass of fly-wheel is decreased to a relatively small 25 – 30 tons. The unit mass of a fly-wheel is significantly cheaper than unit mass of the electric condenser.

The offered design of the magnetic launcher has many innovations which help to overcome the

obstacles afforded by a conventional railgun. Itemizing some of them:

1. Fly-wheels from artificial fiber.
2. Small variable reducer with smooth change of turns and high variable rate.
3. Multi-stage monopolar electric generator having capacity of producing millions of amperes and a variable high voltage during a short time.
4. Sliding mercury (gallium) contact having high pass capacity.
5. Double switch having high capacity and short time switching.
6. Special design of projectile (conductor ring) having permanent contact with electric rail.
7. Thin (lead) film on projectile contacts that improve contact of projectile body and the conductor rail.
8. Homopolar generator has magnets inserted into a disk (wheel) form. That significantly simplifies the electric generator.
9. The rails and electric generator can have internal water-cooling.
10. The generator can return rotation energy back to a flywheel after shooting, while rails can return the electromagnetic energy to installation. That way a part of shot energy may be returned. This increases the coefficient of efficiency of the launch installation.

The fly-wheel has a disadvantage in that it decreases its' turning speed when one spends its energy. The prospective space apparatus and space launcher needs, on the contrary, an increase of voltage for accelerating the payload. The homopolar generator really would like to increase the number of revolutions thus increasing the voltage. The offered variable reducer approaches this ideal, keeping constant or even increasing the speed of rotation of the electric generator. In addition, the multi-stage electric generator can additionally increase its' voltage by chaining (concatenation of turning on in series mode) its stages or sections.

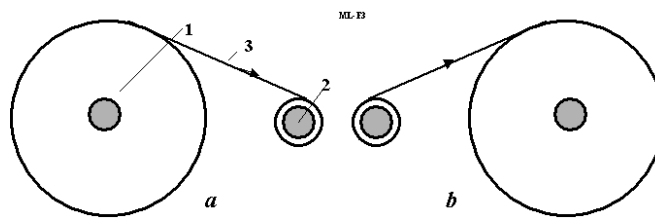


**Fig. 12-2.** Drive station. (a) Main components of drive station; (b) Rotors and connection disks (wheels); (c) Association of rotor and connection disk; (d) Association of shell and electric rails (plough or sled). *Notations:* 1 – Electric homogenerator; 2, 4, 6 – master drive clutch; 3 – variable reducer; 5 – fly-wheel; 7 – engine; 8 – enter of electric line; 9 – exit of electric line; 10 – disk (wheel) of rotor (rigid attachment to shaft 17); 11 – motionless conductor (rigid attachment to stator); 12 – electric current; 13 – sliding contact; 14, 15 – exit conductor; 16 –



double switch from electric line 14 to conductor 11; 18 – sliding contact; 19 – mercury; 20 – electric ring; 21 – thin film; 22 – electric rail.

The sketch of the variable reducer is shown in fig. 12-3. The tape (inertial transfer roll) 3 rotates from shaft 1 (electric generator) to shaft 2 (fly-wheel). In starting position the tape (roll) diameter  $d_1$  of shaft 1 is big while the tape (roll) diameter  $d_2$  of the fly-wheel is small and rotation speed of electric generator is small. During the rotation, the tape (roll) diameter of shaft 1 decreases, while the corresponding diameter around shaft 2 increases and the rotation speed of the electric generator increases (assuming a correct design of the reducer). The total change of the rotation speed is  $(d_1/d_2)^2$ . For example, if  $d_1/d_2 = 7$ , the total change of rotary speed is 49. This way the rotation speed of the electric generator either increases or stays constant in spite of the fact that the rotary speed of the flywheel is decreasing. The multi-stage electric generator achieves the additional increasing of voltage. Its' sections turn on in series.



**Fig. 12-3.** Variable reducer. (a) Start position; (b) final position. *Notations:* 1 – shift of electric generator; 2 – shift of fly-wheel; 3 – tape (inertial transfer roll).

### Conclusion

The research shows the magnetic launcher can be built by the current technology. This significantly (by a thousand times) decreases the cost of space launches. Unfortunately, if we want to use the short rail way (412 m), any launcher request a big acceleration about  $7.5 \cdot 10^3 g$  and may be used only for unmanned, hardened payload. If we want design the manned launcher the rail way must be 1100 km for acceleration  $a = 3g$  (untrained passengers) and about 500 km ( $a = 6g$ ) for trained cosmonauts.

Our design is not optimal. For example, the computation shows, if we increase our rail track only by 15 m, we do not need gas gun initial acceleration. That significantly decreases the cost of installation and simplifies its construction.

The reader can recalculate the installation for his own scenarios.

## 13. Lower Current and Plasma Magnetic Railguns\*

It is well-known that the magnetic railgun theoretically allows a very high 'exhaust velocity' of projectile. The USA and England have tried to research and develop working railgun installations. However the researchers had considerable problems in testing. The railgun requests very high (millions of amperes,) electric current (but low voltage). As result the rails and contacts burn and melt. The railgun can make only ONE shot between repairs, cannot shoot a big and high speed projectile, and has low efficiency.

The heat and inductive losses of railgun depend upon the square of electric current. If we decrease electric current by ten times, we decrease the losses by one hundred times. But the current design of railgun does not allow decreasing the current because that leads to loss --also by the square-- of electromotive force.

In this article the author describes new ideas, theory and computations for design of new magnetic lower cost accelerators for railgun projectiles and space apparatus. This design decreases the requested electric current (and loss) in hundreds times. This design requires a similar increase in voltage (because the energy for acceleration is the same). But no super heating, burn and melting rails, contacts, or big losses. The power and mass of projectiles and space apparatus can be increased in a lot of times. High voltage current does not require special low voltage equipment and may be used directly from the electric stations, saving huge amounts of money.

Author also suggests a new plasma magnetic accelerator, which has no traditional sliding mechanical contacts, significantly decreases the mass of electrical contacts and increases the useful mass of projectile in comparison with a conventional railgun.

Important advantages of the offered design are the lower (up to some tens of times) usage of electric current of high voltage and a very high efficiency coefficient closeto 95% (compare with efficiency of the current railgun which equals 20 – 40%). The suggested accelerators may be produced by present technology.

The projects of railguns are computed herein.

-----  
 \*See also [4], <http://www.scribd.com/doc/24057930> . <http://www.scribd.com/doc/31090728>  
<http://www.archive.org/details/Macro-projectsEnvironmentsAndTechnologies>

## Description of Innovations and Problems in AB-Launchers

### Low current multi-loop Railguns

**Description of multi-loop Launchers .** The conventional magnetic accelerator (railgun) is shown in fig. 13-1. That contains two the conductive rails connected by a **sliding** jumper. Electric current produces the magnetic field and magnetic force. The jumper accepts the magnetic force and accelerates the projectile. Main defects of conventional rail gun: The rail gun requires a gigantic current (millions of amperes) of low voltage, rails have large electric resistance, strongly heating up, contacts burn, installation is damaged and requires repair after every shot. The energy charge is high (small coefficient of efficiency). You see the gigantic plasma column behind the small projectile in fig.13-2 (left)). The repulsive force between rails is gigantic (thousands of tons) and installation is thus heavy and expensive if it is to survive a single shot.

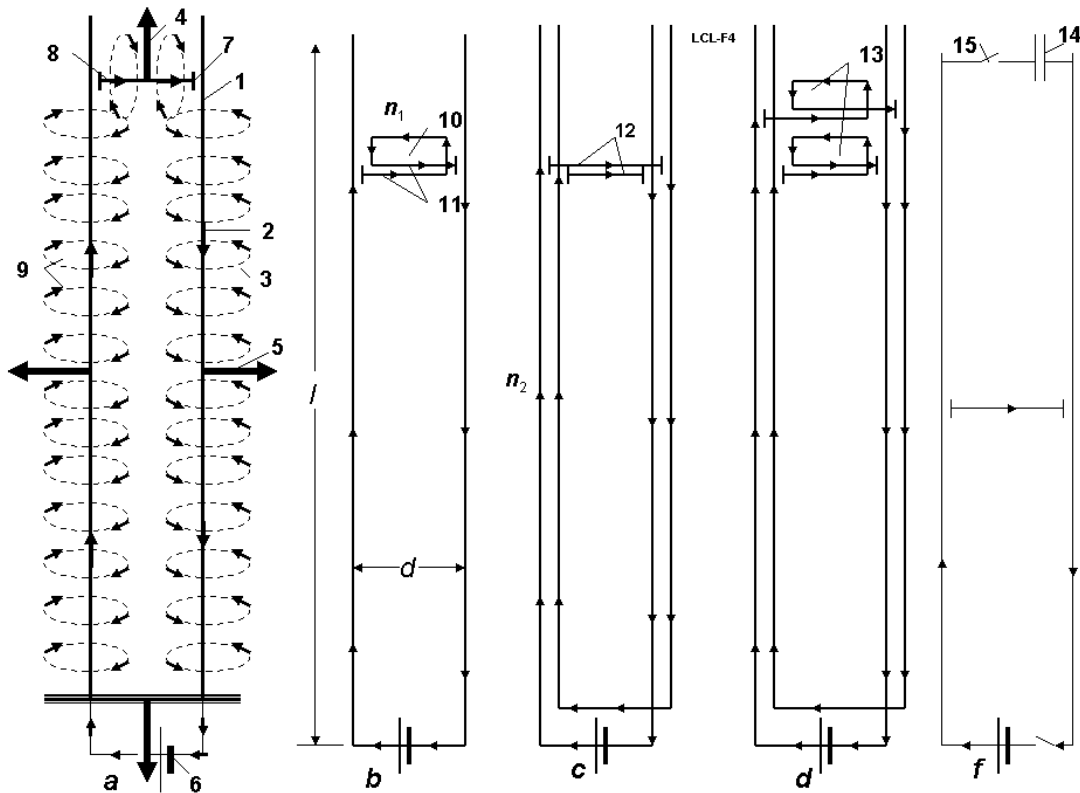
*Description..* The fig. 13-3a shows the principal scheme of the conventional railgun. The installation of fig.3a includes the long vertical wire 2, moved jumper 8, sliding contacts 7 and electric source 6. The electric current produces the magnetic field 3 (magnetic column), the magnetic field creates the vertical 4 and horizontal 5 forces. Vertical force 4 accelerates the useful load at top of the installation.

This design is used in a rail gun [4] but the author made many innovations that allow applying these ideas to this new application as the efficient magnetic accelerators. Some of them are listed below.

**Innovations.** The figs. 13-1b-1f show schemes of the suggested accelerators The author offers the following innovations having the next advantages:

1) *Version 1* (fig. 13-1b). The horizontal wire (fig. 13-1a, former sliding jumper 8 of fig. 13-1a) is made in a form of closed-loop spool (fig. 13-1b, #10). The lower part of this spool (fig. 13-1b, #11) located in place of former jumper near the magnetic field of vertical wire (fig. 13-1b). The top part of this spool (fig. 13-1b, #10) located at top – out of the magnetic field of vertical wire 2. As the result the magnetic field of the vertical wire 2 activates only on horizontal wires 11. But now we have here not one wire with current  $i$ , we have  $n$  wires and current  $ni$ . The magnetic force 4 and requested 4 voltage increases by  $n$  times! The force spool 10 can have some hundreds loops and force will be more in same times than in case of fig. 13-1a. For same vertical force the electric current in the vertical connection wires 2 may be decreases in  $n_1 = n$  times, where  $n_1$  is number of horizontal loops. The electric current may be relatively small (only some tens of thousands of amperes, not millions)

and of the high voltage. The request vertical wire may be relatively thin. The heating, contact and inductive losses decrease in  $n_1$  times, where  $n_1$  is number of horizontal loops. The number of contacts  $N=2$  is same (not increases).



**Fig. 13-1.** Conventional and low current launchers. (a) Conventional high current and low voltage railgun; (b) Offered low current launcher with the wire horizontal multi-loops (version 1); (c) Offered low current launcher with the wire vertical multi-loops (version 2); (d) Offered low current launcher with the wire horizontal and vertical multi-loops (version 3); (f) RailGun with condenser. (version 4). *Notations:* 1 – installation, 2 – vertical wire, 3 – magnetic field from vertical wire; 4 – moved vertical force from jumper; 5 – magnetic force from vertical electric wire, 6 – electric source, 7- sliding contact, 8 – horizontal jumper, 9 - magnetic column, 10 – multi-loop spool, 11, 12 – horizontal force wire connected in one bunch, 13 – force multi-loops spools connected in one spool, 14 – condenser, 15 – electric switch.

- 2) *Version 2* (fig.13-1c). Installation contains the vertical closed loops  $n_2$ . For same vertical force the electric current decreases in  $n_2$  times, the voltage increases by  $n_2$  times. The number of contacts  $N$  also increases by  $n_2$  times. But heating of every contact decreases by  $n_2^2$ . Common electric heat, contact and inductive losses decrease by  $n_2$  times.
- 3) *Version 3* (fig. 13-1d). That is composition of versions 1 and 2. For same vertical force the electric current decreases by  $n_1 n_2$  times. The number of contacts  $N$  increases in  $n_2$  times. But heating of every contact decreases by  $n_1 n_2$ . Common electric heat, contact and inductive losses decrease in  $n_1 n_2$  times.
- 4) *Version 4* (fig.13-1f). The main electric loss in conventional railgun is an inductive loss, which produces a gigantic inductive current and plasma flash. This loss may be significantly decreases by switching the condenser in the end of the projectile track.

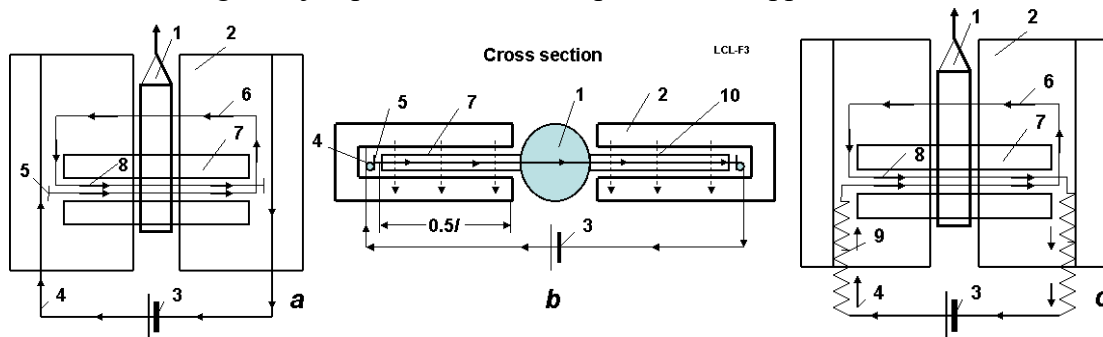
The main innovation is a top loop 10 (right angle spool [4]), which increases the number of horizontal wires 11 (multi-loops), magnetic intensity in area under 11 and lift force 4. We can make a lot of loops up to some hundreds and increase the lift force by hundreds of times. For a given lift force

we can decrease the required current in many times and decreases the mass of the source wire 2. That does not necessarily mean that we decrease the required electric energy (power) because the new installation needs a higher voltage.

### Multi-loop Railguns with permanent magnets

Main function of the vertical wire 2 (fig. 13-1a) creates the magnetic field between wire 2. This field interacts with the magnetic field from a jumper 8 (fig. 13-1a) or the horizontal wires 11 (fig. 13-1b), 12 (fig. 13-1c) and creates the vertical force 4 (fig. 13-1a). For getting enough force requires a high electric current. However, the needed intensity magnetic field we can produce by means of conventional magnets.

This idea explored in multi-loop launcher (accelerator) is offered in fig. 13-2. The launcher has two strong magnets 2 and the multi-loop spool 6. The spool connects through the sliding contacts 5 (fig. 13-2a) to the electric source 3. The design of fig. 13-2c has the spring wires 9 and not has the sliding contacts 5. The suggested launcher has two the motive magnetic jumpers 7, which significantly increase and close the magnetic lines in the lower part 8 of the force spool 6. The top part of the force spool has not the magnetic jumper 7 and does not produce the opposing motive force.



**Fig. 13-2.** Offered launcher with the permanent magnets. (a) Top view; (b) Cross section; (c) Launcher having the spring wires. *Notations:* 1 – projectile, 2 – magnet, 3 – electric source, 4 – electric current, 5 – sliding contact, 6 – force (jumper) multi-loop spool (top part); 7 - magnetic jumper; 8 – lower part of the multi-loop top (force) electric spool; 9 – the spring electric wire; 10 – magnetic lines;  $0.5l$  is length of a magnetic active zone in one side of wire.

The offered accelerator is closest to the direct current linear electric engine but has four differing important features: It has a spool part of it located out of the strong magnetic lines, the installation has the motive magnetic jumpers, the installation uses constant non-interrupted current, launcher can omit the sliding contacts (fig. 13-4c).

This magnetic accelerator may be suitable for a space launcher having small accelerations.

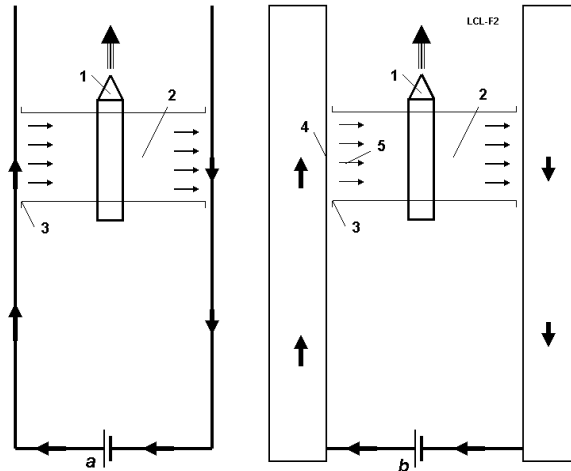
### Plasma magnetic launcher

The jumper 4 (fig. 13-1a), force spools 10, 12, 13 (figs. 13-1b,c,d), magnetic jumpers 7 (fig. 13-2) can have a big mass and significantly decrease the useful load (in 2 – 3 and more times). For decreasing of this imperfect the author offers the plasma jumper (fig. 13-3). Plasma in jumper has very small mass because plasma has a small density. The plasma can have a high conductivity closed to a metal conductor. But plasma conductor (jumper) can have a big cross-section area and a low electric resistance. Electric conductivity of plasma does not depend from its density. The plasma may be very rarefied. That means the head transfer to walls of a channel may be very small and so not damage them. For example the plasma of Earth radiation belts has a million degrees but spaceman and space apparatus not damage.

The thin wire may be initial initiator of a of plasma cable. Then a plasma conductor supports the big current.

The second advantage of plasma launcher is a gas sliding contact. That cannot burn and is more robust against damage.

The offered plasma cable may be used in other technical fields [2] –[4]. This problem needs further research.



**Fig.13-3.** Offered plasma launchers. (a) Launcher having conventional vertical wire and plasma jumper; (b) Launcher having vertical and horizontal (jumper) plasma wires. *Notations:* 1- projectile, 2 – horizontal plasma jumper, 3 – gas sealing, 4 – conducting tube, 5 – electric current into plasma.

## Conclusion

In this article the author describes the new ideas, theory and computations for design the new low electric current launchers for the railgun projectile and space apparatus.

Important advantage of the offered design is the lower (up some tens times) used electric current of high voltage and the very high inductive efficiency coefficient close to 0.9 (compared with efficiency of the current railgun equal to 20 – 40%). The suggested launchers may be produced by present technology.

The problems of needed electric energy become far simpler. At first, AB-Launchers have a high efficiency and spend in 2 – 3 times less energy than a conventional railgun; the second, AB-Launcher uses the high voltage energy closed to a voltage of the electric stations. That means the power electric station can be directly connected to AB-Launcher in period of acceleration without expensive transformers and condensers. The power of strong electric plant is enough for launching the space apparatus of some hundreds of kilograms.

The offered magnetic space launcher is a thousand times cheaper than the well-known cable space elevator. NASA is spending for research of space elevator hundreds of millions of dollars. A small part of this sum is enough for R&D of the magnetic launcher and to make a working model.

The proposed innovation (multi- electric AB-spool, permanent magnetic rails, plasma magnetic launcher) allows also solving the problem of the conventional railgun (having the projectile speed 3 -5 km/s). The current conventional railgun uses a very high ampere electric current (millions A) and low voltage. As the result the rails corrode, burn, melt The suggested AB-spool allows decreases the required the electric current by tens of times (simultaneously the required voltage is increased by the same factor).

Small cheap magnetic prototypes would be easily tested.

The computed projects are not optimal. That is only illustration of an estimation method. The reader can recalculate the AB-Launchers for his own scenarios (see also [1]-[4]).

## 14. Superconductivity Space Accelerator \*

In this Chapter the author describes a new idea, theory and computations for design of a new magnetic low cost accelerator for railgun projectile and space apparatus. The suggested design does not have the traditional current rails and sliding contacts. This accelerates the projectile and space apparatus by a magnetic column which can have a length of some kilometers, produces a very high acceleration and projectile (apparatus) final speed of up to 8 - 10 km/s.

Important advantages of the offered design is the low (up to some thousands of times) used electric current of high voltage and very high efficiency coefficient close to 1 (compare with efficiency of the current railgun which equals 20 – 40%). The suggested accelerator may be produced by present technology.

The projects: railgun and space accelerator are computed in [4].

-----  
\* Magnetic Space AB-Accelerator. <http://www.scribd.com/doc/26885058> , or [4].

### Description of Innovations and Problems

#### New type of magnetic acceleration (magnetic AB-column)

**1. Description of Innovations.** The conventional magnetic accelerator (railgun) is shown in fig.1. That contains two the conductive rails connected by a **sliding** jumper. Electric currents produce the magnetic field and magnetic force. The jumper accepts the magnetic force and accelerates the projectile. Main defects of conventional rail gun: The rail gun requires a gigantic current (millions of amperes) of low voltage, rails have large electric resistance, strongly heating up, contacts burn, installation is damaged and requires repair after every shot. The energy charge is high (small coefficient of efficiency. You see the gigantic plasma column behind the small projectile in [4] Ch.6, fig.2). The repulsive force between rails is gigantic (thousands of tons) and installation is thus heavy and expensive if it is to survive a single shot.

*Description.* The fig.1a shows the suggested accelerator without the force and connection spools. Installation includes the long vertical loop from electric wire 1 and electric source 6. The electric current 2 produces the magnetic field 3 (magnetic column), the magnetic field creates the vertical 4 and horizontal 5 forces. These forces balance the film (or filament, fiber) connection 15. Vertical force 4 accelerates the useful load at top of the installation and supports wires and film connection).

This design is used in a rail gun [4] but the author made many innovations that allow applying this idea to this new application as an efficient magnetic accelerator. Some of them are listed below.

*Innovations.* The author offers the following innovations having the next advantages:

- 1) The horizontal wire (fig. 14-1a, #2a, former sliding jumper) is made in a form of closed-loop spool (fig. 14-1b, #11). The lower part of this spool (fig. 14-1b, #12) located in place of former jumper near the magnetic field of vertical wire (fig. 14-1b). The top part of this spool (fig. 14-1b, #13) located at top – out of the magnetic field of vertical wire 2. As the result the magnetic field of the vertical wire 2 activates only on horizontal wires 12. But now we have here not one wire 2a with current  $i$ , we have  $n$  wires and current  $ni$ . The magnetic force 17 and requested voltage increases by  $n$  times! The force spool 11 can have some thousands loops and force 17 will be more in same times then in case 2a of fig. 14- 3a. That means the electric current in the connection wires 2 may be relatively small (only some thousands of amperes, not millions) and of high voltage. The request vertical wire may be relatively thin.
- 2) Application of special connection spool. The accelerator has the connection spool 7 (fig. 14-1, detail spool in fig. 14-2). That allows increases the acceleration distance up to some kilometers and deletes the sliding electric contacts.

- 3) The wire is superconductive and has special design (fig. 14-2). That allows simply cooling the wires in a short time (the superconductivity needs a low temperature). Their cooling time may be short because requested time of acceleration may be short. For example, rail gun shot lasts about 0.1 second, the space apparatus acceleration is about tens seconds.
- 4) Absence of long rails. ‘Confinement recoil’ of projectile is accepted by the magnetic columns 3a (fig. 14-1a) from vertical wires [4].

The main innovation is a top loop 11 (right angle spool [4]), which increases the number of horizontal wires 12, magnetic intensity in area 17 and lift force 16. We can make a lot of loops up to some thousands and increase the lift force by thousands of times. For a given lift force we can decrease the required current in many times and decreases the mass of source wire 2. That does not necessarily mean that we decrease the required electric power because the new installation needs a higher voltage. The proposed construction creates the MAGNETIC COLUMN 3a that produces a lift force some thousands of times more than a conventional rail gun.

The second important innovation is the connection spool, which increases the acceleration distance, deletes the sliding contacts and heavy rails.

*Quadratic magnetic column.* The quadratic four wire magnetic column ([4], Fig.2) is more efficient, stable, safe, reliable and controlled than two wire magnetic column Fig. 14-1. It can control of space ship direction (by changing current in vertical wires). It is important for high altitude space apparatus.

**2. Connection spools.** The connection spools can be located at accelerator and at the ground. Every design has its advantages and limitations. Three constructions of the connection spools are presented in fig. 14-2. The first design (fig. 14-4a) has immobile vertical spools. That is simple but results in a limited safe high speed of the launched apparatus and requires the connection device 9. The second design (fig. 14-2b) has the horizontal spool rotated by an engine. This connection spool is limited by the safe rotary speed of the spool and also requires the connection device 9. The third design (fig. 14-2c) has engine and also limited by a safety rotary of spool, but it does not request the connection device 9 because the wires are connected by fiber before spooling in the connection spool.

The limitation is about 1 – 3 km/s for the current artificial fiber (whiskers) having a safe tensile stresses about 200 - 1000 kgf/mm<sup>2</sup>. But if we use nanotubes, the limit is more by 5 -10 times.

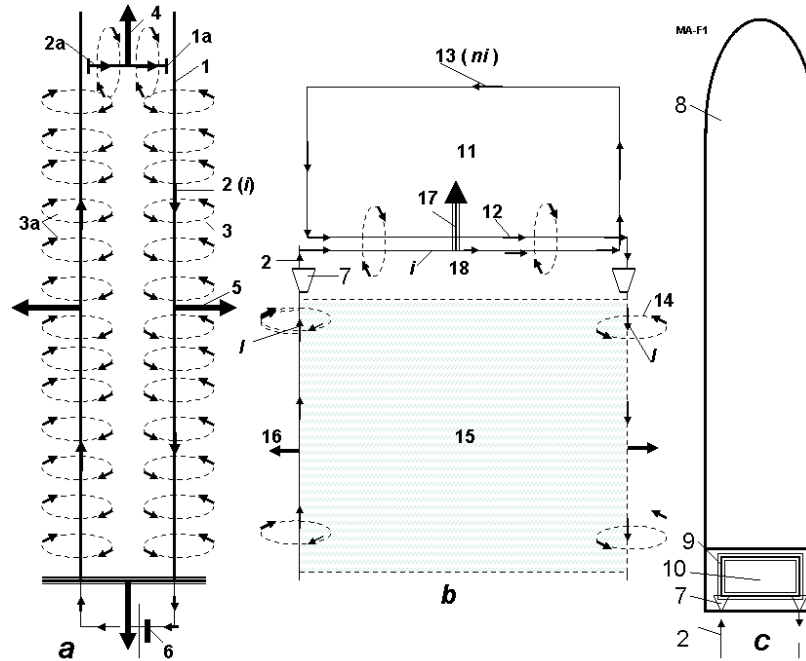
**3. Cooling system of superconductive wire.** The current superconductive conductors do not spend electric energy and pass very large electric current densities, but they require an cooling system because the current superconductive materials have the critical temperature of about 100 - 180 K (see Table #1 below). The wire located into Earth’s atmosphere (up 50 – 80 km) needs cooling.

However, the present computational methods of heat transfer are well developed and the weight and the induced expenses for cooling are small (for example, cooling by liquid nitrogen) [4] (see also Computation and Projects sections).

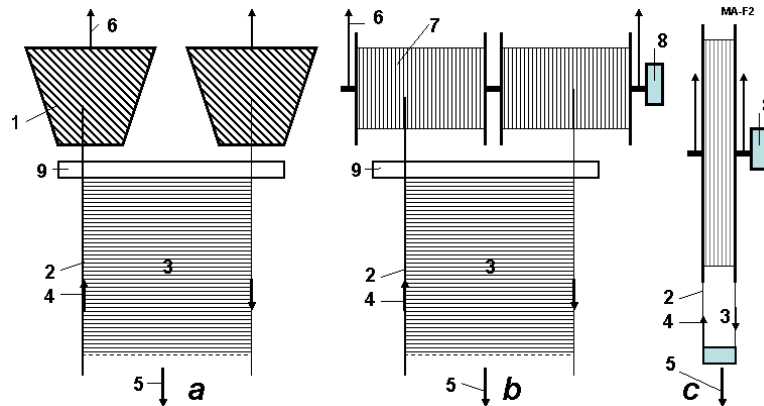
The suggested design of a cooled superconductive wire is present in fig. 14-3. The wire contains two elastic tubes. The insulated internal tube is coated inside-- the superconductive layer, outside is coated--the highly reflective layer. The outer tube is made from the strong artificial fiber and covered by the highly reflective layers. The space between tubes is vacuumed or filed by air (it is worse but may apply for short cooling time) or heat protection.

The wire works the following way. The liquid nitrogen (77 K) from special heat protection capsule is injected into the internal tube in many places (needles) and instantly cooling the superconductive layer to lower than the critical temperature.





**Fig. 14-1.** Principal sketch of the Magnetic AB-Accelerator. *Notations:* (a) Principal sketch of conventional (one turn) magnetic accelerator, (b) – Multi-loop force spool at top of accelerator (same force spool located at ground), (c) – rocket (projectile) with detachable magnetic accelerator at bottom. *Parts:* 1 – magnetic installation with magnetic column, 1a – sliding contact, 2 – vertical wire and direction of electric current  $i$ , 2a – horizontal wire (jumper) and direction of electric current  $i$ , 3 – magnetic field from vertical electric wire, 3a – magnetic column, 4 – magnetic force from horizontal electric wire (jumper), 5 – magnetic force from vertical electric wire, 6 – electric source, 7 – connection spool, 8 – rocket (projectile), 9 – force spool, 10 – magnetic accelerator, 11 – wire multi-loop superconductive force spool at top (same spool located also on Earth surface), 12 – lower wires of loop (force spool), 13 – top wires of loop (force spool), 14 – magnetic field from vertical wire, 15 – thin film or artificial fiber connected the vertical wires for compensation the magnetic repulse force, 16 – repulsive magnetic force, 17 – acceleration force, 18 – area strong magnetic field,  $i$  – electric current in vertical wire,  $ni$  – electric current in the force spool.



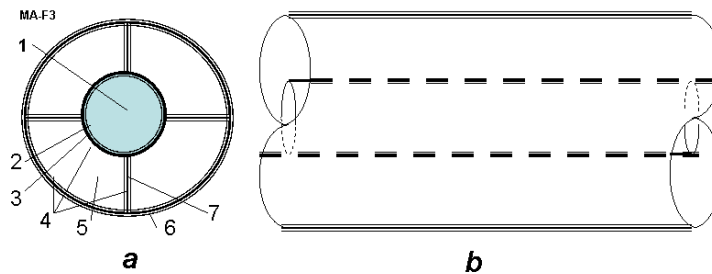
**Fig. 14-2.** Possible installations of connection spools for AB-Accelerator. *Notations:* (a) Immobile vertical connection spool, (b) Rotated horizontal connection spool, (c) Type connection spool. *Parts:* 1 – immobile vertical connection spool, 2 – vertical superconductive wire, 3 – filaments connected the vertical wire and

keeping the repulsive magnetic force of vertical wires, 4 – electric current, 5 – motion of connection wire, 6 – vertical wire to the force spool, 7 – connection wire in connection spool, 8 – engine for rotation of the connection spool, 9 – device for connection the vertical wires by filaments.

While the nitrogen evaporates the temperature is 77 K and installation can accelerate the projectile or space apparatus. After acceleration the accelerator separates, wires are spooling and installation is ready for next shot.

#### 4. Superconductive materials.

There are hundreds of new superconductive materials (type 2) having critical temperature  $70 \div 120$  K and more. Some of the superconductable materials are presented in Table 1 (2001). The widely used  $\text{YBa}_2\text{Cu}_3\text{O}_7$  has mass density  $7 \text{ g/cm}^3$ .



**Fig. 14-3.** Superconductive wires. (a) Cross-section of superconductive wires, (b) – side view. *Notations:* 1 - strong elastic tube (internal part is used for cooling of superconductive layer by liquid nitrogen, external part is used for reflective layer), 2 – superconductive layer, 3 - insulator, 4 – high reflective layer, 5 – vacuum or air, or heat-insulated material (fiber), 6 – strong outer tube (internal and external surface is covered by reflective coating), 7 – connection the internal and outer tubes.

**Table 1.** Transition temperature  $T_c$  and upper critical magnetic field  $B = H_{c2}(0)$  of some examined superconductors AIP, Physics desk references, 3<sup>rd</sup> ed., p. 752.

Crystal	$T_c$ (K)	$H_{c2}$ (T)
$\text{La}_{2-x}\text{Sr}_x\text{CuO}_4$	38	$\geq 80$
$\text{YBa}_2\text{Cu}_3\text{O}_7$	92	$\geq 150$
$\text{Bi}_2\text{Sr}_2\text{Ca}_2\text{Cu}_3\text{O}_{10}$	110	$\geq 250$
$\text{TlBa}_2\text{Ca}_2\text{Cu}_3\text{O}_9$	110	$\geq 100$
$\text{Tl}_2\text{Ba}_2\text{Ca}_2\text{Cu}_3\text{O}_{10}$	125	$\geq 150$
$\text{HgBa}_2\text{Ca}_2\text{Cu}_3\text{O}_8$	133	$\geq 150$

The last decisions are: Critical temperature is 176 K, up to 183 K. Nanotube has critical temperature of 12 - 15 K,

Some organic matters have a temperature of up to 15 K. Polypropylene, for example, is normally an insulator. In 1985, however, researchers at the Russian Academy of Sciences discovered that as an oxidized thin-film, polypropylene have a conductivity  $10^5$  to  $10^6$  that is higher than the best refined metals.

Boiling temperature of liquid nitrogen is 77.3 K, air 81 K, oxygen 90.2 K, hydrogen 20.4 K, helium 4.2 K. Specific density of liquid air is  $920 \text{ kg/m}^3$ , nitrogen  $804 \text{ kg/m}^3$ ; evaporation heat is liquid air is  $213 \text{ kJ/kg}$ , nitrogen  $199 \text{ kJ/kg}$ .

Unfortunately, most superconductive material is not strong and needs a strong covering for structural support.

**5. Advantages.** The offered magnetic accelerator has big advantages in comparison with railguns and other space launchers. Compare it with the space rocket.

1. The AB-Accelerator is very cheap. The cost is about one million USD (rail gun) to some millions (space launcher) [4].
2. The consumables cost is very small and primarily the needed electric energy (about 3 – 5 \$/kg)[4].
3. The productivity is very high (tens launches in day).
4. The accelerator uses the current well developed technology and may be researched and developed in a short time.
5. The accelerator (special platform) may initially to accelerate current rockets up to speed 700 – 1000 m/s and lift them to the altitude 5 – 10 km. That increases the payload the current rockets up 50% .
6. Accelerator uses the high voltage (up to 1 MV) electric currency. That allows to directly connect accelerator to current power electric stations (in night time during periods of slack power use) and to launch a space apparatus without expensive electric energy storage in the form of capacitors (used in present time).
7. Accelerator has a coefficient of energy efficiency closed to 1. It is the most efficient among the known space launchers.

In comparison with current Railgun the suggested accelerator has the following advantages:

8. No problem with burn of rail and contact.
9. No damage and repair of installation after every shot.
10. Limit in speed of projectile is high (7 – 9 km/s).
11. No limit to mass of projectile.
12. Installation is cheaper.
13. Installation requires ~2 – 3 times less of energy than same output conventional railgun.

**6. Application and further development.** Idea of the magnetic AB-column may be applied to the suspending of houses, buildings, towns, multi-floor cities, to a small flying city-state located over ocean in the international water, (avoiding some of the liabilities of sea-surface communities during storms) to levitating space stations, to communication masts and towers [4]. This idea may be easily tested in small cheap magnetic constructions for simple projects, on a small scale.

## Conclusion

In this chapter the author describes new idea, theory and computations for design the new magnetic low cost accelerator for railgun projectile and space apparatus. The suggested design does not have the traditional current rails and sliding contacts. That accelerates the projectile and space apparatus by a magnetic column which can have a length of some kilometers, produces the very high acceleration and the projectile (apparatus) speed up 8 km/s.

Important advantage of the offered design is the lower (up some thousands times) used electric current of high voltage and the very high efficiency coefficient close to 1 (compared with efficiency of the current railgun equal to 20 – 40%). The suggested accelerator may be produced by present technology.

The important advantage of the offered method for space apparatus is following: The method does not need designing new rockets. What is needed is to design only a simple accelerator (accelerate platform). Any current rocket may be installed on this platform and accelerated up high speed and

lifted on high altitude before started. That radically increases payload and decreases the cost of launching. The platform (force spool) and wires disconnects from the rocket after acceleration. Platform returns by parachute, the wires reel back to start.

The problems of needed electric energy become far simpler. At first, AB-Accelerator has very high efficiency and spend in 2 – 3 times less energy then a conventional railgun; the second, AB-Accelerator uses the high voltage energy same with voltage the electric stations. That means the power electric station can be directly connected to AB-Accelerator in period of acceleration without expensive transformers and condensers. The power of strong electric plant is enough for launching the rocket (space apparatus) of some hundreds of tons.

The offered magnetic space accelerator is a thousand times cheaper than the well-known cable space elevator. NASA is spending for research of space elevator hundreds of millions of dollars. A small part of this sum is enough for R&D of the magnetic accelerator and make a working model!

The proposed innovation (upper electric AB-spool) allows also solving the problem of the conventional railgun (having the projectile speed 3 -5 km/s). The current conventional railgun uses a very high ampere electric current (millions A) and low voltage. As the result the rails burn. The suggested superconductive AB-spool allows decreases the required electric current by thousands of times (simultaneously the required voltage is increased by the same factor). No rails, therefore no damage to the rails.

Small cheap magnetic prototypes would be easily tested.

The computed projects (in [4]) are not optimal. That is only illustration of an estimation method. The reader can recalculate the AB-Accelerator for his own scenarios (see also [1]-[4]).

## **15. Converting of Matter to Nuclear Energy by AB-Generator and Photon Rocket\***

Author offers a new nuclear generator which allows to convert any matter to nuclear energy in accordance with the Einstein equation  $E=mc^2$ . The method is based upon tapping the energy potential of a Micro Black Hole (MBH) and the Hawking radiation created by this MBH. As is well-known, the vacuum continuously produces virtual pairs of particles and antiparticles, in particular, the photons and anti-photons. The MBH event horizon allows separating them. Anti-photons can be moved to the MBH and be annihilated; decreasing the mass of the MBH, the resulting photons leave the MBH neighborhood as Hawking radiation. The offered nuclear generator (named by author as AB-Generator) utilizes the Hawking radiation and injects the matter into MBH and keeps MBH in a stable state with near-constant mass.

The AB-Generator can produce gigantic energy outputs and should be cheaper than a conventional electric station by a factor of hundreds of times. One also may be used in aerospace as a photon rocket or as a power source for many vehicles.

Many scientists expect the Large Hadron Collider at CERN will produce one MBH every second. A technology to capture them may follow; than they may be used for the AB-Generator.

---

\* Presented as Paper AIAA-2009-5342 in 45 Joint Propulsion Conferences, 2–5 August, 2009, Denver, CO, USA. See also Converting of Any Matter to Nuclear Energy by-AB-Generator  
<http://www.scribd.com/doc/24048466/>,

<http://www.scipub.org/fulltext/ajeas/ajeas24683-693.pdf>

Converting of any Matter to Nuclear Energy by AB-Generator and Aerospace ,

<http://www.archive.org/details/ConvertingOfAnyMatterToNuclearEnergyByAb-generatorAndAerospace> ,

## AB-Generator of Nuclear Energy and some Innovations

**Simplified explanation of MBH radiation and work of AB-Generator** ([7], Fig.5). As known, the vacuum continuously produces, virtual pairs of particles and antiparticles, in particular, photons and anti-photons. In conventional space they exist only for a very short time, then annihilate and return back to nothingness. The MBH event horizon, having very strong super-gravity, allows separation of the particles and anti particles, in particular, photons and anti-photons. Part of the anti-photons move into the MBH and annihilate with photons decreasing the mass of the MBH and return back a borrow energy to vacuum. The free photons leave from the MBH neighborhood as Hawking radiation. That way the MBH converts any conventional matter to Hawking radiation which may be converted to heat or electric energy by the AB- Generator. This AB- Generator utilizes the produced Hawking radiation and injects the matter into the MBH while maintaining the MBH in stable suspended state.

**Note:** The photon does NOT have rest mass. Therefore a photon can leave the MBH's neighborhood (if it is located beyond the event horizon). All other particles having a rest mass and speed less than light speed *cannot* leave the Black Hole. They cannot achieve light speed because their mass at light speed equals infinity and requests infinite energy for its' escape—an impossibility.

**Description of AB- Generator.** The offered nuclear energy AB- Generator is shown in fig. 15-1. That includes the Micro Black Hole (MBH) 1 suspended within a spherical radiation reflector and heater 5. The MBH is supported (and controlled) at the center of sphere by a fuel (plasma, proton, electron, matter) gun 7. This AB- Generator also contains the 9 – heat engine (for example, gas, vapor turbine), 10 – electric generator, 11 – coolant (heat transfer agent), an outer electric line 12, internal electric generator (5 as antenna) with customer 14.

**Work.** The generator works the following way. MBH, by selective directional input of matter, is levitated in captivity and produces radiation energy 4. That radiation heats the spherical reflector-heater 5. The coolant (heat transfer agent) 11 delivers the heat to a heat machine 9 (for example, gas, vapor turbine). The heat machine rotates an electric generator 10 that produces the electricity to the outer electric line 12. Part of MBH radiation may accept by sphere 5 (as antenna) in form of electricity.

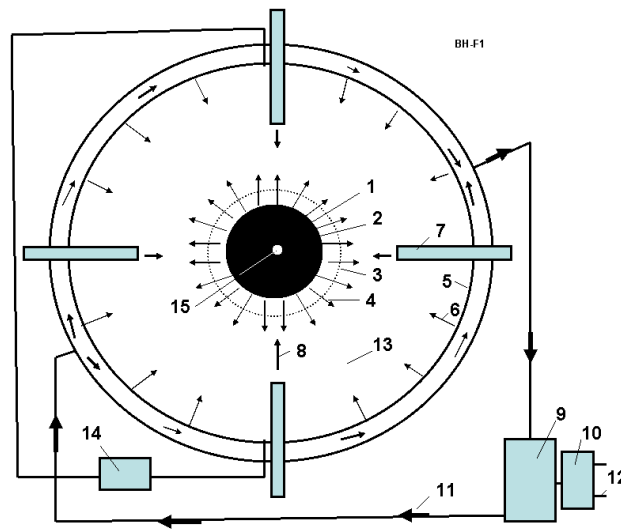
The control fuel guns inject the matter into MBH and do not allow bursting of the MBH. This action also supports the MBH in isolation, suspended from dangerous contact with conventional matter. They also control the MBH size and the energy output.

Any matter may be used as the fuel, for example, accelerated plasma, ions, protons, electrons, micro particles, etc. The MBH may be charged and rotated. In this case the MBH may have an additional suspension by control charges located at the ends of fuel guns or (in case of the rotating charged MBH) may have an additional suspension by the control electric magnets located on the ends of fuel guns or at points along the reflector-heater sphere.

## Innovations, features, advantages and same research results

Some problems and solutions offered by the author include the following:

- 1) A practical (the MBH being obtained and levitated, details of which are beyond the scope of this paper) method and installation for converting any conventional matter to energy in accordance with Einstein's equation  $E = mc^2$ .



**Fig. 15-1.** Offered nuclear-vacuum energy AB- Generator. *Notations:* 1- Micro Black Hole (MBH), 2 - event horizon (Schwarzschild radius), 3 - photon sphere, 4 – black hole radiation, 5 – radiation reflector, antenna and heater (cover sphere), 6 – back (reflected) radiation from radiation reflector 5, 7 – fuel (plasma, protons, electrons, ions, matter) gun (focusing accelerator), 8 – matter injected to MBH (fuel for Micro Black hole), 9 – heat engine (for example, gas, vapor turbine), 10 – electric generator connected to heat engine 9, 11 – coolant (heat transfer agent to the heat machine 9), 12 – electric line, 13 – internal vacuum, 14 – customer of electricity from antenna 5, 15 – singularity.

- 2) MBHs may produce gigantic energy and this energy is in the form of dangerous gamma radiation. The author shows how this dangerous gamma radiation Doppler shifts when it moves against the MBH gravity and converts to safely tapped short radio waves.
- 3) The MBH of marginal mass has a tendency to explode (through quantum evaporation, very quickly radiating its mass in energy). The AB- Generator automatically injects metered amounts of matter into the MBH and keeps the MGH in a stable state or grows the MBH to a needed size, or decreases that size, or temporarily turns off the AB- Generator (decreases the MBH to a Planck Black Hole).
- 4) Author shows the radiation flux exposure of AB- Generator (as result of MBH exposure) is not dangerous because the generator cover sphere has a vacuum, and the MBH gravity gradient decreases the radiation energy.
- 5) The MBH may be supported in a levitated (non-contact) state by generator fuel injectors.

### AB-Generator as Photon Rocket

The offered AB- Generator may be used as the most efficient photon propulsion system (photon rocket). The photon rocket is the dream of all astronauts and space engineers, a unique vehicle) which would make practical interstellar travel. But a functioning photon rocket would require gigantic energy. The AB- Generator can convert any matter in energy (radiation) and gives the maximum theoretical efficiency.

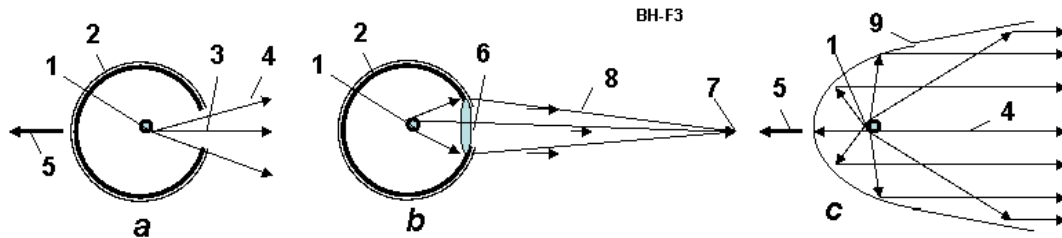
The some possible photon propulsion system used the AB –Generator is shown in Fig.15-2. In simplest version (*a*) the cover of AB generator has window 3, the radiation goes out through window and produces the thrust. More complex version (*c*) has the parabolic reflector, which sends all radiation in one direction and increases the efficiency. If an insert in the AB- Generator covers the lens 6 which will focuses the radiation in a given direction, at the given point the temperature will be a billions

degree (see Equation (2)) and AB-Generator may be used as a photon weapon.

The maximal thrust  $T$  of the photon engine having AB- Generator may be computed (estimated) by equation:

$$T = \dot{M}c, \quad \text{N}, \quad (26)$$

For example, the AB-generator, which spends only 1 gram of matter per second, will produce a thrust  $3 \times 10^5$  N or 30 tons.



**Fig. 15-2.** AB-Generator as Photon Rocket and Radiation (Photon) Weapon. (a) AB- Generator as a Simplest Photon Rocket; (b) AB- Generator as focused Radiation (photon, light or laser) weapon; (c) Photon Rocket with Micro-Black Hole of AB-Generator. *Notations:* 1 – control MBH; 2 – spherical cover of AB-Generator; 3 – window in spherical cover; 4 – radiation of BH; 5 – thrust; 6 – lens in window of cover; 7 – aim; 8 - focused radiation; 9 – parabolic reflector.

## Results:

1. Author has offered the method and installation for converting any conventional matter to energy according the Einstein's equation  $E = mc^2$ , where  $m$  is mass of matter, kg;  $c = 3 \cdot 10^8$  is light speed, m/s.
2. The Micro Black Hole (MBH) is offered for this conversion.
3. Also is offered the control fuel guns and radiation reflector for explosion prevention of MBH.
4. Also is offered the control fuel guns and radiation reflector for the MBH control.
5. Also is offered the control fuel guns and radiation reflector for non-contact suspension (levitation) of the MBH.
6. For non contact levitation of MBH the author also offers:
  - a) Controlled charging of MBH and of ends of the fuel guns.
  - b) Control charging of rotating MBH and control of electric magnets located on the ends of the fuel guns or out of the reflector-heater sphere.
7. The author researches show the very important fact: A strong gamma radiation produced by Hawking radiation loses energy after passing through the very strong gravitational MBH field. The MBH radiation can reach the reflector-heater as the light or short-wave radio radiation. That is very important for safety of the operating crew of the AB- Generator.
8. The author researches show: The matter particles produced by the MBH cannot escape from MBH and can not influence the Hawking radiation.
9. The author researches show another very important fact: The MBH explosion (hundreds and thousands of TNT tons) in radiation form produces a small pressure on the reflector-heater (cover sphere) and does not destroys the AB-generator (in a correct design of AB-generator!). That is very important for safety of the operating crew of the AB-generator.
10. The author researches show another very important fact: the MBH cannot capture by oneself the surrounding matter and cannot automatically grow to consume the planet.
11. As the initial MBH can be used the Planck's (quantum) MBH which *may* be everywhere.  
The offered fuel gun may to grow them (or decrease them) to needed size or the initial MBH



may be used the MBH produce Large Hadron Collider (LHC) at CERN. Some scientists assume LHC will produce one MBH every second (86,400 MBH in day). The cosmic radiation also produces about 100 MBH every year.

12. The spherical dome of MBH may convert part of the radiation energy to electricity.
13. A correct design of MBH generator does not produce the radioactive waste of environment.
14. The attempts of many astronomers find (detect) the MBH by a MBH exposure radiation will not be successful without knowing the following: The MBH radiation is small, may be detected only over a short distance, does not have specific frequency and has a variable long wavelength.

### **Discussing**

We got our equations in assumption  $\lambda/\lambda_o = r/r_o$ . If  $\lambda/\lambda_o = (r/r_o)^{0.5}$  or other relation, the all above equations may be easy modified.

The Hawking article was published 34 years ago (1974)[4]. After this time the hundreds of scientific works based in Hawking work appears. No facts are known which creates doubts in the possibility of Hawking radiation but it is not proven either. The Hawking radiation may not exist. The Large Hadron Collider has the main purpose to create the MBHs and detect the Hawking radiation.

### **Conclusion**

The AB-Generator could create a revolution in many industries (electricity, car, ship, transportation, etc.). That allows designing photon rockets and flight to other star systems. The maximum possible efficiency is obtained and a full solution possible for the energy problem of humanity. These overwhelming prospects urge us to research and develop this achievement of science [4],[7].

## **16. Femtotechnology: the Strongest AB-Matter with Fantastic Properties and their Applications in Aerospace\***

At present the term ‘nanotechnology’ is well known – in its’ ideal form, the flawless and completely controlled design of conventional molecular matter from molecules or atoms. Such a power over nature would offer routine achievement of remarkable properties in conventional matter, and creation of metamaterials where the structure not the composition brings forth new powers of matter.

But even this yet unachieved goal is not the end of material science possibilities. The author herein offers the idea of design of new forms of nuclear matter from nucleons (neutrons, protons), electrons, and other nuclear particles. He shows this new ‘AB-Matter’ has extraordinary properties (for example, tensile strength, stiffness, hardness, critical temperature, superconductivity, supertransparency, zero friction, etc.), which are up to millions of times better than corresponding properties of conventional molecular matter. He shows concepts of design for aircraft, ships, transportation, thermonuclear reactors, constructions, and so on from nuclear matter. These vehicles will have unbelievable possibilities (e.g., invisibility, ghost-like penetration through any walls and armour, protection from nuclear bomb explosions and any radiation flux, etc.)

People may think this fantasy. But fifteen years ago most people and many scientists thought – nanotechnology is fantasy. Now many groups and industrial labs, even startups, spend hundreds of millions of dollars for development of nanotechnological-range products (precise chemistry, patterned atoms, catalysts, metamaterials, etc) and we have nanotubes (a new material which does not exist in Nature!) and other achievements beginning to come out of the pipeline in prospect. Nanotubes are stronger than steel by a hundred times—surely an amazement to a 19<sup>th</sup> Century observer if he could behold them.

Nanotechnology, in near term prospect, operates with objects (molecules and atoms) having the size in nanometer ( $10^{-9}$  m). The author here outlines perhaps more distant operations with objects (nuclei) having size in the femtometer range, ( $10^{-15}$  m, millions of times less smaller than the nanometer scale). The name of this new technology is femtotechnology.

-----  
 \*Femtotechnology: Design of the Strongest AB-Matter for Aerospace

<http://www.archive.org/details/FemtotechnologyDesignOfTheStrongestAb-matterForAerospace> or  
 American Journal of Engineering and Applied Science, Vol. 2, #2, 2009, pp.501-514.

<http://www.scipub.org/fulltext/ajeas/ajeas22501-514.pdf>

## Innovations and computations

**Short information about atom and nuclei.** Conventional matter consists of atoms and molecules. Molecules are collection of atoms. The atom contains a nucleus with proton(s) and usually neutrons (Except for Hydrogen-1) and electrons revolve around this nucleus. Every particle may be characterized by parameters as mass, charge, spin, electric dipole, magnetic moment, etc. There are four forces active between particles: strong interaction, weak interaction, electromagnetic charge (Coulomb) force and gravitational force. The nuclear force dominates at distances up to 2 fm (femto, 1 fm =  $10^{-15}$  m). They are hundreds of times more powerful than the charge (Coulomb force and million-millions of times more than gravitational force. Charge (Coulomb) force is effective at distances over 2 fm. Gravitational force is significant near and into big masses (astronomical objects such as planets, stars, white dwarfs, neutron stars and black holes). Strong force is so overwhelmingly powerful that it forces together the positively charged protons, which would repel one from the other and fly apart without it. The strong force is key to the relationship between protons, neutrons and electrons. They can keep electrons into or near nuclei. Scientists conventionally take into attention only of the strong force when they consider the nuclear and near nuclear size range, for the other forces on that scale are negligible by comparison for most purposes.

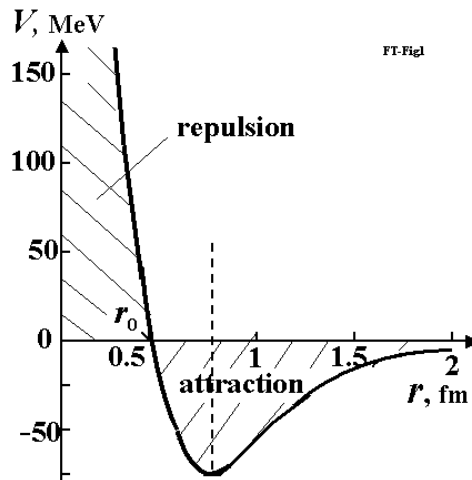
Strong nuclear forces are anisotropic (non spherical, force distribution not the same in all directions equally), which means that they depend on the relative orientation of the nucleus.

Typical nuclear energy (force) is presented in fig. 16-1. When it is positive the nuclear force repels the other atomic particles (protons, neutrons, electrons). When nuclear energy is negative, it attracts them up to a distance of about 2 fm. The value  $r_0$  usually is taken as radius of nucleus. Average interaction energy between to nucleus is about 8 MeV, distance where the attractive strong nuclear force activates is at about 1 – 1.2 fm.

**2. AB-Matter.** In conventional matter made of atoms and molecules the nucleons (protons, neutrons) are located in the nucleus, but the electrons rotate in orbits around nucleus in distance in millions times more than diameter of nucleus. Therefore, in essence, what we think of as solid matter contains a --relatively! --‘gigantic’ vacuum (free space) where the matter (nuclei) occupies but a very small part of the available space. Despite this unearthly emptiness, when you compress this (normal, non-degenerate) matter the electrons located in their orbits repel atom from atom and resist any great increase of the matter’s density. Thus it feels solid to the touch.

The form of matter containing and subsuming all the atom’s particles into the nucleus is named *degenerate matter*. Degenerate matter found in white dwarfs, neutron stars and black holes.

**Conventionally this matter in such large astronomical objects has a high temperature (as independent particles!)** and a high gravity adding a forcing, confining pressure in a very massive celestial objects. In nature, degenerate matter exists stably (as a big lump) to our knowledge only in large astronomical masses (include their surface where gravitation pressure is zero) and into big nuclei of conventional matter.



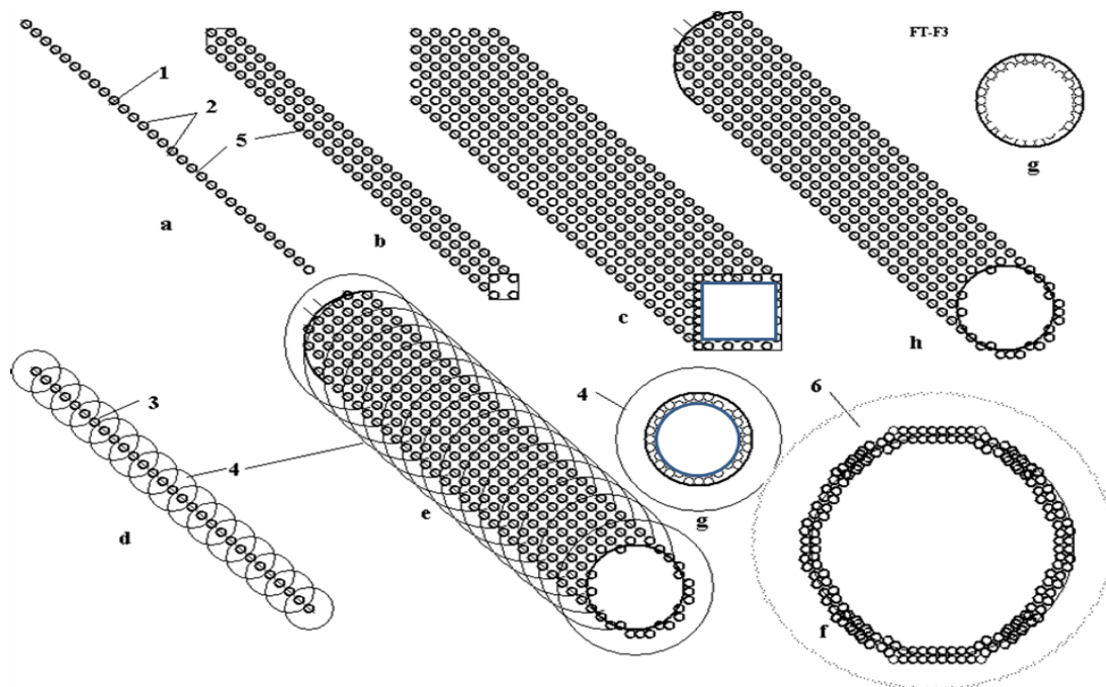
**Fig. 16-1.** Typical nuclear force of nucleus. When nucleon is at distance of less than 1.8 fm, it is attracted to nucleus. When nucleon is very close, it is repulsed from nucleus.

(Reference from <http://www.physicum.narod.ru> , Vol. 5 p. 670).

Our purpose is to design artificial small masses of synthetic degenerate matter in form of an extremely thin strong thread (fiber, filament, string), round bar (rod), tube, net (dense or non dense weave and mesh size) which can exist at Earth-normal temperatures and pressures. Note that such stabilized degenerate matter in small amounts does not exist in Nature as far as we know. Therefore I have named this matter **AB-Matter** (fig.16-2). Just as people now design by the thousands variants of artificial materials (for example, plastics) from usual matter, we soon (historically speaking) shall create many artificial, designer materials by nanotechnology (for example, nanotubes: SWNTs (amchair, zigzag, ahiral, graphen), MWNTs (fullorite, torus, nanobut), nanoribbon (plate), buckyballs (ball), fullerene). Sooner or later we may anticipate development of femtotechnology and create such AB-Matter. Some possible forms of AB-Matter are shown in fig.10. Offered technologies are  $\text{MТ}$  [8]. The threads from AB-Matter are stronger by millions of times than normal materials. They can be inserted as reinforcements, into conventional materials, which serve as a matrix, and are thus strengthened by thousands of times (see computation section in [8]).

**3. Some offered technologies for producing AB-Matter.** One method of producing AB-Matter may use the technology reminiscent of computer chips ([8], fig.11). The stability and other method of production AB-matter considered in the article preparing for publication.

Various other means are under consideration for generation of AB-Matter, what is certain however that once the first small amounts have been achieved, larger and larger amounts will be produced with ever increasing ease. Consider for example, that once we have achieved the ability to make a solid AB-Matter film (a sliced plane through a solid block of AB-matter), and then developed the ability to place holes with precision through it one nucleon wide, a modified extrusion technique may produce AB-Matter strings (thin fiber), by passage of conventional matter in gas, liquid or solid state through the AB-Matter matrix (mask). This would be a ‘femto-die’ as Joseph Friedlander of Shave Shomron, Israel, has labeled it. Re-assembling these strings with perfect precision and alignment would produce more AB-matter film; leaving deliberate gaps would reproduce the ‘holes’ in the initial ‘femto-die’.

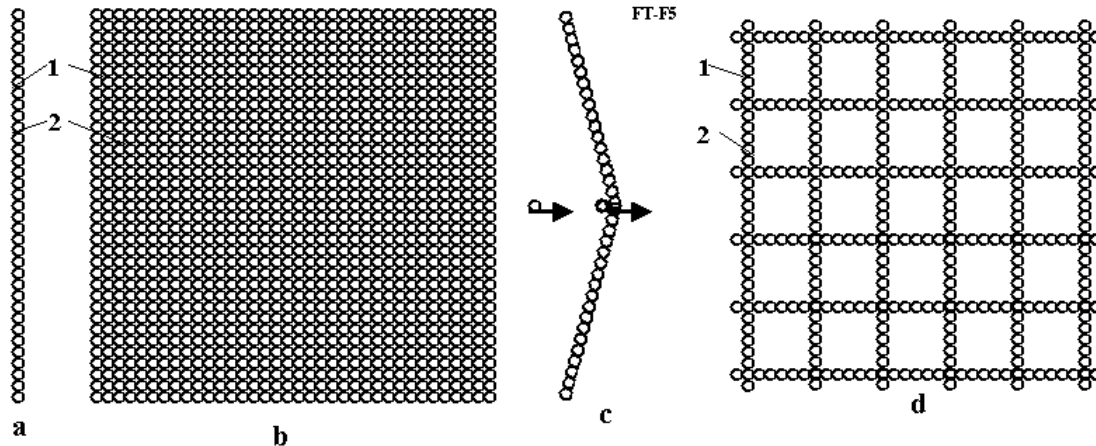


**Fig. 16-2.** Design of AB-Matter from nucleons (neutrons, protons, etc.) and electrons (a) linear one string (monofilament) (fiber, whisker, filament, thread); (b) ingot from four nuclear monofilaments; (c) multi-ingot from nuclear monofilament; (d) string made from protons and neutrons with electrons rotated around monofilament; (e) single wall femto tube (SWFT) fiber with rotated electrons; (f) cross-section of multi wall femto tube (MWFT) string; (g) cross-section of rod; (h) - single wall femto tube (SWFT) string with electrons inserted into AB-Matter. *Notations:* 1 – nuclear string; 2 - nucleons (neutrons, protons, etc.). 3 – protons; 4 – orbit of electrons; 5 – electrons; 6 – cloud of electrons around tube.

The developing of femtotechnology is easier, in one sense, than the developing of fully controllable nanotechnology because we have only three main particles (protons, neutrons, their ready combination of nuclei  ${}^2\text{D}$ ,  ${}^3\text{T}$ ,  ${}^4\text{He}$ , etc., and electrons) as construction material and developed methods of their energy control, focusing and direction.

**3. Using the AB-Matter** (fig.16-3). The simplest use of AB-Matter is strengthening and reinforcing conventional material by AB-Matter fiber. As it is shown in the ‘Computation’ section [8], AB-Matter fiber is stronger (has a gigantic ultimate tensile stress) than conventional material by a factor of millions of times, can endure millions degrees of temperature, don’t accept any attacking chemical reactions. We can insert (for example, by casting around the reinforcement) AB-Matter fiber (or net) into steel, aluminum, plastic and the resultant matrix of conventional material increases in strength by thousands of times—if precautions are taken that the reinforcement stays put! Because of the extreme strength disparity design tricks must be used to assure that the fibers stay ‘rooted’. The matrix form of conventional artificial fiber reinforcement is used widely in current technology. This increases the tensile stress resistance of the reinforced matrix matter by typically 2 – 4 times. Engineers dream about a nanotube reinforcement of conventional matrix materials which might increase the tensile stress by 10 – 20 times, but nanotubes are very expensive and researchers cannot decrease its cost to acceptable values yet despite years of effort.

Another way is using a construct of AB-Matter as a continuous film or net (fig.16-4).



**Fig. 16-3.** Thin film from nuclear matter. (a) cross-section of a matter film from single strings (side view); (b) continuous film from nuclear matter; (c) AB film under blow from conventional molecular matter; (d) – net from single strings. Notations: 1 – nucleons; 2 – electrons inserted into AB-Matter; 3 – conventional atom.

These forms of AB-Matter have such miraculous properties as invisibility, superconductivity, zero friction, etc. The ultimate in camouflage, installations of a veritable Invisible World can be built from certain forms of AB-Matter with the possibility of being also interpenetrable, literally allowing ghost-like passage through an apparently solid wall. Or the AB-Matter net (of different construction) can be designed as an impenetrable wall that even hugely destructive weapons cannot penetrate.

The AB-Matter film and net may be used for energy storage which can store up huge energy intensities and used also as rocket engines with gigantic impulse or weapon or absolute armor (see computation and application sections). Note that in the case of absolute armor, safeguards must be in place against buffering sudden accelerations; g-force shocks can kill even though nothing penetrates the armor!

The AB-Matter net (which can be designed to be gas-impermeable) may be used for inflatable construction of such strength and lightness as to be able to suspend the weight of a city over a vast span the width of a sea. AB-Matter may also be used for cubic or tower solid construction as it is shown in fig. 16-4.

## Some Properties of AB-Matter

We spoke about the *fantastic tensile and compressive strength, rigidity, hardness, specific strength, thermal (temperature) durability, thermal shock, and big elongation of* AB-Matter which are more millions time then conventional matter (see [8]).

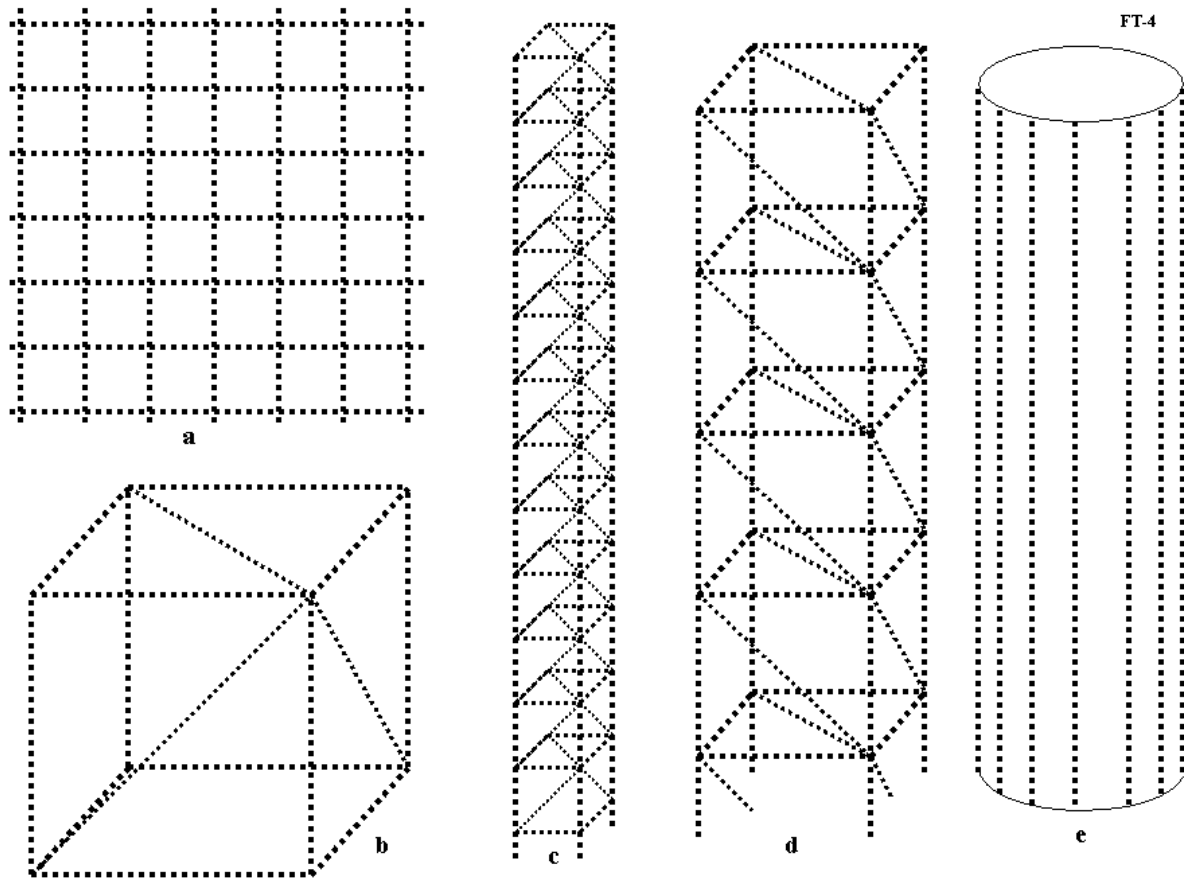
Short note about other miraculous AB-Matter properties:

1. *Zero heat/thermal capacity.* That follows because the mass of nucleons (AB-Matter string, film, net) is large in comparison with mass single atom or molecule and nucleons in AB-Matter have a very strong connection one to other. Conventional atoms and molecules cannot pass their paltry energy to AB-Matter! That would be equivalent to moving a huge dry-dock door of steel by impacting it with very light table tennis balls.

2. *Zero heat/thermal conductivity.* (See above).

3. *Absolute chemical stability. No corrosion, material fatigue. Infinity of lifetime.* All chemical reactions are acted through ORBITAL electron of atoms. The AB-Matter does not have orbital electrons (special cases will be considered later on). Nucleons cannot combine with usual atoms having electrons. In particular, the AB-Matter has *absolute corrosion resistance. No fatigue of material* because in conventional material fatigue is result of splits between material crystals. No crystals in

AB-Matter. That means AB-Matter has lifetime equal to the lifetime of neutrons themselves. Finally a container for the universal solvent!



**Fig.16-4.** Structures from nuclear strings. (a) nuclear net (netting, gauze); (b) primary cube from matter string; (c) primary column from nuclear string; (d) large column where elements made from primary columns; (e) tubes from matter string or matter columns.

**4. Super-transparency, invisibility of special AB-Matter-nets.** An AB-Matter net having a step distance (mesh size) between strings or monofilaments of more than  $100 \text{ fm} = 10^{-13} \text{ m}$  will pass visible light having the wave length  $(400 - 800) \times 10^{-9} \text{ m}$ . You can make cars, aircraft, and space ships from such a permeable (for visible light) AB-Matter net and you will see a man (who is made from conventional matter) apparently sitting on nothing, traveling with high speed in atmosphere or space without visible means of support or any visible vehicle!

**5. Impenetrability for gas, liquids, and solid bodies.** When the AB-Matter net has a step size between strings of less than atomic size of  $10^{-10} \text{ m}$ , it became impenetrable for conventional matter. Simultaneously it may be invisible for people and have gigantic strength. The AB-Matter net may –as armor--protect from gun, cannon shells and missiles.

**6. Super-impenetrability for radiation.** If the cell size of the AB-Matter net will be less than a wave length of a given radiation, the AB-Matter net does not pass this radiation. Because this cell size may be very small, AB net is perfect protection from any radiation up to soft gamma radiation (include radiation from nuclear bomb).

**7. Full reflectivity (super-reflectivity).** If the cell size of an AB-Matter net will be less than a wavelength of a given radiation, the AB-Matter net will then fully reflect this radiation. With perfect reflection and perfect impenetrability remarkable optical systems are possible. A Fresnel like lens might also be constructible of AB-Matter.

**8. Permeable property (ghost-like intangibility power; super-passing capacity).** The AB-Matter net from single strings having mesh size between strings of more than  $100 \text{ nm} = 10^{-11} \text{ m}$  will pass the atoms and molecules through itself because the diameter of the single string ( $2 \times 10^{-15} \text{ m}$ ) is 100 thousand times less than diameter of atom ( $3 \times 10^{-10} \text{ m}$ ). That means that specifically engineered constructions from AB-Matter can be built on the Earth, but people will not see and feel them. The power to phase through walls, vaults, and barriers has occasionally been portrayed in science fiction but here is a real life possibility of it happening.

**9. Zero friction.** If the AB-Matter net has a mesh size distance between strings equals or less to the atom ( $3 \times 10^{-10} \text{ m}$ ), it has an ideal flat surface. That means the mechanical friction may be zero. It is very important for aircraft, sea ships and vehicles because about 90% of its energy they spend in friction. Such a perfect surface would be of vast value in optics, nanotech molecular assembly and prototyping, physics labs, etc.

**10. Super or quasi-super electric conductivity at any temperature.** As it is shown in previous section the AB-Matter string can have outer electrons in an arrangement similar to the electronic cloud into metal. But AB-Matter strings (threads) can be located along the direction of the electric intensity and they will not resist the electron flow. That means the electric resistance will be zero or very small.

**11. High dielectric strength** (see Equation (21) in [4] Ch.2).

AB-Matter may be used for devices to produce high magnetic intensity.

**12. Transfer pressure in long distance.** The pressure force of AB-string is very high and does NOT depend from its length (that will be shown in the next author research). That means we can penetrate into the human body without damage it from distance in hundreds kilometers, into the Earth (geological exploration), into other planets (Moon, Mars) without flight to them, keep the motion less satellites and build the Space Elevator from Earth surface.

## Applications and new systems in Aerospace and aviation

The applications of the AB-Matter are encyclopedic in scope. This matter will create revolutions in many fields of human activity. We show only non-usual applications in aerospace, aviation that come to mind, and by no means all of these.

### 1. Storage of gigantic energy.

As it is shown in [3]-[7], the energy saved by flywheel equals the special mass density of material (17). As you see that is a gigantic value of stored energy because of the extreme values afforded by the strong nuclear force. Car having a pair of 1 gram counterspun fly-wheels (2 grams total) (20) charged at the factory can run all its life without benzene. Aircraft or sea ships having 100 gram (two 50 gram counterspun fly-wheels) can fly or swim all its life without additional fuel. The offered flywheel storage can has zero friction and indefinite energy storage time.

### 2. New propulsion system of space ship.

The most important characteristic of rocket engine is specific impulse (speed of gas or other material flow out from propulsion system). Let us compute the speed of a part of fly-wheel ejected from the offered rocket system

$$\frac{mV^2}{2} = E, \quad V = \sqrt{\frac{2E}{m}} = 3.9 \cdot 10^7 \text{ m/s.} \quad (1)$$

Here  $V$  is speed of nucleon, m/s;  $E = 12.8 \times 10^{-13} \text{ J}$  (1) is energy of one nucleon, J;  $m = 1.67 \times 10^{-27} \text{ kg}$  is mass of one nucleon, kg. The value (1) is about 13% of light speed.

The chemical rocket engine has specific impulse about 3700 m/s. That value is 10 thousand times less. The electric rocket system has a high specific impulse but requires a powerful compact and light source of energy. In the offered rocket engine the energy is saved in the flywheel. The current projects



of a nuclear rocket are very complex, heavy, and dangerous for men (gamma and neutron radiation) and have specific impulse of thousands of times less (1). The offered AB-Matter rocket engine may be very small and produced any rocket thrust in any moment in any direction.

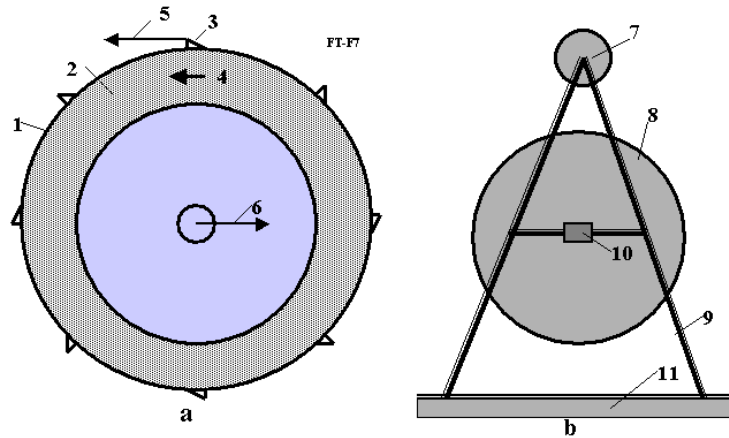
The offered flywheel rocket engine used the AB-matter is presented in fig.16-5a. That is flywheel made from AB-matter. It has a nozzle 3 having control of exit mass. The control allows to exit of work mass in given moment and in given position of flywheel. The flywheel rotates high speed and the exhaust mass leave the rocket engine with same speed when the nozzle is open. In result the engine has thrust 6. As exhaust mass may be used any mass: liquid (for example, water), sand, small stones and other suitable planet or space material (mass). The energy needed for engine and space ship is saved in the revolving flywheel. This energy may be received at started planet or from space ship engine.

The rocket used the suggested engine is shown in fig. 5b. That has a cabin 7, the offered propulsion system 8, undercarriage 9 and rotary mechanism 10 for turning the ship in need position.

Let us to estimate the possibility of offered rocket. Notate, the relation of the exhaust mass to AM-matter cover mass of flywheel are taken  $a = 10$ , the safety (strength) factor  $b = 4$ . About 20% of space ship is payload and construction and 80% is the exhaust mass. Then exhaust speed of throw away mass and receiving speed by space ship are:

$$V = \sqrt{\frac{k}{ab}} = 2.12 \cdot 10^6 \text{ m/s}, \quad m_s V_s = m V, \quad V_s = \frac{m}{m_s} V = \frac{0.8}{0.2} \cdot 2.12 \cdot 10^6 = 8.48 \cdot 10^6 \text{ m/s}, \quad (2)$$

where  $V$  speed of exhausted mass, m/s;  $k = \sigma/d = 1.9 \times 10^{14} \text{ (m/s)}^2$  is strength coefficient (16);  $m_s$  is final mass of rocket, kg;  $V_s = 8480 \text{ km/s}$  is final speed of rocket, m/s;  $m$  is throw off mass, kg.



**Fig. 16-5.** Schema of new rocket and propulsion system. (a) Propulsion system from AB matter and storage energy. (b) Rocket with offered propulsion system.

*Notations:* 1 – cover (flywheel) from AB-matter; 2 – any work mass; 3 – nozzle with control of exit mass; 4 – direction of rotation; 5 – direction of exhaust mass; 6 – thrust; 7 – space ship; 8 – offered propulsion system; 9 – undercarriage; 10 – rotary mechanism; 11 – planet surface.

## 6. High efficiency rocket, jet and piston aviation engines.

The efficiency conventional jet and rocket engines are very limited by the temperature and safety limits of conventional matter (2000°K). If we will design the rotor blades (in jet engine), combustion chamber (in rocket and piston engines) from AB-Matter, we radically improve their capacities and simplify their construction (for example, no necessary cooling system!).

## 7. Hypersonic aircraft.

The friction and heat which attacks conventional materials for hypersonic aircraft limits their speed. Using the AB-Matter deletes this problem. Many designs for aerospace planes could capture oxygen in

flight, saving hauling oxidizer and carrying fuel alone—enabling airliner type geometries and payloads since the weight of the oxidizer and the tanks needed to hold it, and the airframe strengths required escalate the design and cascade through it until conventional materials today cannot build a single stage to orbit or antipodes aerospace plane. But that would be quite possible with AB-Matter.

### **8. Increasing efficiency of a conventional aviation and transport vehicles.**

AB-Matter does not experience friction. The air drag in aviation is produced up 90% by air friction on aircraft surface. Using AB-Matter will make jump in flight characteristics of aircraft and other transport vehicles (including sea ships and cars).

### **9. Improving capabilities of all machines.**

Appearance new high strength and high temperature AB-Matter will produce jump, technology revolution in machine and power industries.

### **10. Computer and computer memory.**

The AB-Matter film allows to write in  $1 \text{ cm}^2$   $N = 1/(4 \times 10^{-26}) = 2.5 \times 10^{25}$   $1/\text{cm}^2$  bits information. The current 45 nanometer technology allows to write only  $N = 2.5 \times 10^{14}$   $1/\text{cm}^2$  bit. That means the main chip and memory of computer based in AB-Matter film may be a billion times smaller and presumably thousands of times faster (based on the lesser distance signals must travel).

The reader can imagine useful application of AB-Matter in any field he is familiar with.

### **11. Penetration in any body in long distance.**

We can penetrate into the human body without damage it from distance in hundreds kilometers, into the interior of the Earth (geological exploration), into other planets (Moon, Mars) without flight to them, keep the motion less satellites and build the Space Elevator from Earth surface.

## **Discussion**

**1. Micro-World from AB-Matter: An Amusing Thought-Experiment.** AB-Matter may have  $10^{15}$  times more particles in a given volume than a single atom. A human being, man made from conventional matter, contains about  $5 \times 10^{26}$  molecules. That means that 200 ‘femto-beings’ of equal complexity from AB-Matter (having same number of components) could be located in the volume of one microbe having size  $10 \mu = 10^{-5}$  m. If this proved possible, we could not see them, they could not see us in terms of direct sensory input. Because of the wavelength of light it is questionable what they could learn of the observable macro-Universe. The implications, for transhuman scenarios, compact interstellar (microbe sized!) payloads, uploading and other such scenarios are profound. It is worth recalling that a single house and garden required to support a single conventional matter human is, for AB-Matter ‘femto-beings’, equivalent in relative vastness as the extended Solar system is for us. If such a future form could be created and minds ‘uploaded’ to it, the future theoretical population, knowledge base, and scholarly and knowledge-industries output of even a single planet so populated could rival that of a theoretical Kardashev Type III galactic civilization!

### **2. Stability of AB-matter.**

Readers usually ask: what is the connection (proton to proton) given a new element when, after 92 protons, the connection is unstable?

*Answer:* That depends entirely on the type of connection. If we conventionally join the carbon atom to another carbon atom a lot of times, we then get the conventional piece of a coil. If we joint the carbon atom to another carbon atom by the indicated special methods, we then get the very strong single-wall nanotubes, graphene nano-ribbon (super-thin film), armchair, zigzag, chiral, fullerite, torus,

nanobud and other forms of nano-materials. That outcome becomes possible because the atomic force (van der Waals force, named for the Dutch physicist Johannes Diderik van der Waals, 1837-1923, etc.) is NON-SPHERICAL and active in the short (one molecule) distance. The nucleon nuclear force also is NON-SPHERICAL and they may also be active about the one nucleon diameter distance (Fig. 16-1). That means we may also produce with them the strings, tubes, films, nets and other geometrical constructions.

The further studies (it will be published) are shown that AB-matter will be stability if:

1) The any sphere having radius  $R \approx 6 \times 10^{-15}$  m in any point of structure figs. 1 – 4 must contain NOT more 238 nucleons (about 92 of them must be protons). That means any cross-section area of the solid rod, beam and so on of AB-structure (for example figs. 16-1b,c,g) must contain NOT more about 36 nucleons.

2) AB-matter must contains the proton in a certain order because the electrostatic repel forces of them give the stability of the given structure.

## Conclusion

The author offers a design for a new form of nuclear matter from nucleons (neutrons, protons), electrons, and other nuclear particles. He shows that the new AB-Matter has most extraordinary properties (for example, (in varying circumstances) remarkable tensile strength, stiffness, hardness, critical temperature, superconductivity, super-transparency, ghostlike ability to pass through matter, zero friction, etc.), which are millions of times better than corresponded properties of conventional molecular matter. He shows how to design aircraft, ships, transportation, thermonuclear reactors, and constructions, and so on from this new nuclear matter. These vehicles will have correspondingly amazing possibilities (invisibility, passing through any walls and amour, protection from nuclear bombs and any radiation, etc).

People may think this fantasy. But fifteen years ago most people and many scientists thought – nanotechnology is fantasy. Now many groups and industrial labs, even startups, spend hundreds of millions of dollars for development of nanotechnological-range products (precise chemistry, patterned atoms, catalysts, metamaterials, etc) and we have nanotubes (a new material which does not exist in Nature!) and other achievements beginning to come out of the pipeline in prospect. Nanotubes are stronger than steel by a hundred times—surely an amazement to a 19<sup>th</sup> Century observer if he could behold them.

Nanotechnology, in near term prospect, operates with objects (molecules and atoms) having the size in nanometer ( $10^{-9}$  m). The author here outlines perhaps more distant operations with objects (nuclei) having size in the femtometer range, ( $10^{-15}$  m, millions of times less smaller than the nanometer scale). The name of this new technology is femtotechnology.

I want to explain the main thrust of this by analogy. Assume we live some thousands of years ago in a great river valley where there are no stones for building and only poor timber. In nature we notice that there are many types of clay (nuclei of atom—types of elemet). One man offers to people to make from clay bricks (AB-Matter) and build from these bricks a fantastic array of desirable structures too complex to make from naturally occurring mounds of mud. The bricks enable by increased precision and strength things impossible before. A new level of human civilization begins.

I call upon scientists and the technical community to to research and develop femtotechnology. I think we can reach in this field progress more quickly than in the further prospects of nanotechnology, because we have fewer (only 3) initial components (proton, neutron, electron) and interaction between them is well-known (3 main forces: strong, weak, electostatic). The different conventional atoms number about 100, most commone molecuels are tens thousands and interactions between them are very complex (e.g. Van der Waals force).

It may be however, that nano and femto technology enable each other as well, as tiny bits of AB-Matter would be marvellous tools for nanomechanical systems to wield to obtain effects unimaginable otherwise.

What time horizon might we face in this quest? The physicist Richard Feynman offered his idea to design artificial matter from atoms and molecules at an American Physical Society meeting at Caltech on December 29, 1959. But only in the last 15 years we have initial progress in nanotechnology. On the other hand progress is becoming swifter as more and better tools become common and as the technical community grows.

Now are in the position of trying to progress from the ancient 'telega' haywagon of rural Russia (in analogy, conventional matter composites) to a 'luxury sport coupe' (advanced tailored nanomaterials). The author suggests we have little to lose and literal worlds to gain by simultaneously researching how to leap from 'telega' to 'hypersonic space plane'. (Femotech materials and technologies, enabling all the wonders outlined here).

## References

Many works noted below the reader can find on site Cornell University <<http://arxiv.org/>>, sites <<http://www.scribd.com>>, <<http://www.archive.org>> search "Bolonkin", <<http://bolonkin.narod.ru/p65.htm>> and in Conferences 2002-2006 (see, for example, Conferences AIAA, <<http://aiaa.org/>>, search "Bolonkin"). \

1. Bolonkin A.A., (2006) "Non-Rocket Space Launch and Flight", Elsevier, 2005, <http://www.archive.org/details/Non-rocketSpaceLaunchAndFlight>, <http://www.scribd.com/doc/24056182>
2. Bolonkin A.A. (2006), Book "New Concepts, Ideas and Innovation in Aerospace", NOVA, 2008. <http://www.scribd.com/doc/24057071>. <http://www.archive.org/details/NewConceptsIfeasAndInnovationsInAerospaceTechnologyAndHumanSciences>
3. Bolonkin A.A. (2007), "Macro-Engineering: Environment and Technology", pp. 299-334, NOVA, 2008. <http://Bolonkin.narod.ru/p65.htm>, <http://www.scribd.com/doc/24057930>. <http://www.archive.org/details/Macro-projectsEnvironmentsAndTechnologies>
4. Bolonkin A.A. (2008), "New Technologies and Revolutionary Projects", Scribd, 2008, 324 pgs, <http://www.scribd.com/doc/32744477>, <http://www.archive.org/details/NewTechnologiesAndRevolutionaryProjects>
5. Bolonkin A.A., (2006). Electrostatic AB-Ramjet Space Propulsion. <http://arxiv.org/ftp/physics/papers/0701/0701073.pdf>
6. Bolonkin A.A., (2009). Magnetic Space AB-Accelerator. <http://www.scribd.com/doc/26885058>
7. Bolonkin A.A., (2009). Converting of any Matter to Nuclear Energy by AB-Generator and Aerospace <http://www.archive.org/details/ConvertingOfAnyMatterToNuclearEnergyByAb-generatorAndAerospace> American Journal of Engineering and Applied Science, Vol. 2, #4, 2009, pp.683-693. <http://www.scipub.org/fulltext/ajeas/ajeas24683-693.pdf>.
8. Bolonkin A.A., (2009). Femtotechnology: Design of the Strongest AB-Matter for Aerospace <http://www.archive.org/details/FemtotechnologyDesignOfTheStrongestAb-matterForAerospace> American Journal of Engineering and Applied Science, Vol. 2, #2, 2009, pp.501-514. <http://www.scipub.org/fulltext/ajeas/ajeas22501-514.pdf>.
9. Bolonkin A.A., Book "Non-Rocket Space Launch and Flight", Elsevier. 2006, Ch. 9 "Kinetic Anti-Gravotator", pp. 165-186; <http://Bolonkin.narod.ru/p65.htm>, <http://www.scribd.com/doc/24056182>; Main idea of this Chapter was presented as papers COSPAR-02, C1.1-0035-02 and IAC-02-IAA.1.3.03, 53<sup>rd</sup> International Astronautical Congress. The World Space Congress-2002, 10-19 October 2002, Houston, TX,

- USA, and the full manuscript was accepted as AIAA-2005-4504, 41<sup>st</sup> Propulsion Conference, 10-12 July 2005, Tucson, AZ, USA. <http://aiaa.org> search "Bolonkin".
10. Bolonkin A.A., Book "Non-Rocket Space Launch and Flight", Elsevier. 2006, Ch.5 "*Kinetic Space Towers*", pp. 107-124, Springer, 2006. <http://Bolonkin.narod.ru/p65.htm> or <http://www.scribd.com/doc/24056182> .  
<http://www.archive.org/details/Non-rocketSpaceLaunchAndFlight>
  11. Bolonkin A.A., "*Transport System for Delivery Tourists at Altitude 140 km*", manuscript was presented as paper IAC-02-IAA.1.3.03 at the World Space Congress-2002, 10-19 October, Houston, TX, USA.  
<http://Bolonkin.narod.ru/p65.htm> ,
  12. Bolonkin A.A. (2003), "*Centrifugal Keeper for Space Station and Satellites*", JBIS, Vol.56, No. 9/10, 2003, pp. 314-327. <http://Bolonkin.narod.ru/p65.htm> . See also [11] Ch.3.
  13. Bolonkin A.A., Book "Non-Rocket Space Launch and Flight", by A.Bolonkin, Elsevier. 2006, Ch.3 "*Circle Launcher and Space Keeper*", pp.59-82. <http://www.scribd.com/doc/24056182> ,  
<http://www.archive.org/details/Non-rocketSpaceLaunchAndFlight>
  14. Bolonkin A.A., Book "New Concepts, Ideas and Innovation in Aerospace", NOVA, 2008, Ch. 3 "*Electrostatic AB-Ramjet Space Propulsion*", pp.33-66. <http://www.scribd.com/doc/24057071>.  
<http://www.archive.org/details/NewConceptsIfeasAndInnovationsInAerospaceTechnologyAndHumanSciences>
  15. Bolonkin A.A., Book "New Concepts, Ideas and Innovation in Aerospace", NOVA, 2008, Ch.12, pp.205-220. Ch. "*AB Levitrons and Their Applications to Earth's Motionless Satellites*".  
<http://www.scribd.com/doc/24057071> ,  
<http://www.archive.org/details/NewConceptsIfeasAndInnovationsInAerospaceTechnologyAndHumanSciences>
  16. Bolonkin A.A., Book "Macro-Projects: Environment and Technology", NOVA, 2008, Ch.10, pp.199-226, "*AB-Space Propulsion*", <http://www.scribd.com/doc/24057930> ,  
<http://Bolonkin.narod.ru/p65.htm> .  
<http://www.archive.org/details/Macro-projectsEnvironmentsAndTechnologies> .
  17. Bolonkin A.A., Magnetic Suspended AB-Structures and Moveless Space Satellites.  
<http://www.scribd.com/doc/25883886> .
  18. Bolonkin A.A., Femtotechnology: Design of the Strongest AB-Matter for Aerospace.  
<http://www.archive.org/details/FemtotechnologyDesignOfTheStrongestAb-matterForAerospace>.
  19. Bolonkin A.A., Converting of any Matter to Nuclear Energy by AB-Generator and Aerospace.  
<http://www.archive.org/details/ConvertingOfAnyMatterToNuclearEnergyByAb-generatorAndAerospace>.
  20. Bolonkin A.A., Krinker M., Magnetic-Space-Launcher. <http://www.scribd.com/doc/24051286/>,  
<http://arxiv.org/ftp/arxiv/papers/0903/0903.5008.pdf>
  21. Bolonkin A.A., LIFE. SCIENCE. FUTURE (Biography notes, researches and innovations). Scribd, 2010, 208 pgs. 16 Mb. <http://www.scribd.com/doc/48229884>,  
<http://www.archive.org/details/Life.Science.Future.biographyNotesResearchesAndInnovations>





Hypersonic aircraft



Rocket Ariès

## Chapter 16

# Review of new ideas, innovations of non-rocket propulsion systems for Space Launch and Flight (Part 3)

### Abstract

In the past years the author and other scientists have published a series of new methods which promise to revolutionize the space technology. These include the Space Elevator, Men without the space suite into space, Artificial gravity, New method of atmospheric re-entry for space ship, Inflatable Dome for Moon, Mars, asteroids, Closed loop water cycle, Climber for Space Elevator, Cheap Protection from Nuclear Warhead, Wireless transfer of electricity throw outer Space, Artificial explosion of Sun, etc.

Some of them have the potential to decrease the space research costs in thousands of time, other allow decreasing the cost of the space exploration.

The author reviews and summarizes some revolutionary ideas, innovations and patent applications for scientists, engineers, inventors, students and the public.

**Key words:** Space Elevator, Men without the space suite into space, Artificial gravity, New method of atmospheric re-entry, Inflatable Dome for space, Closed loop water cycle, Climber for Space Elevator, Cheap protection from Nuclear Warhead, Wireless transfer of electricity throw outer Space, Artificial explosion of Sun.

### Introduction

**Space technology** is technology that is related to entering, and retrieving objects or life forms from space.

"Every day" technologies such as weather forecasting, remote sensing, GPS systems, satellite television, and some long distance communications systems critically rely on space infrastructure. Of sciences astronomy and Earth sciences (via remote sensing) most notably benefit from space technology.

Computers and telemetry were once leading edge technologies that might have been considered "space technology" because of their criticality to boosters and spacecraft. They existed prior to the Space Race of the Cold War (between the USSR and the USA.) but their development was vastly accelerated to meet the needs of the two major superpowers' space programs. While still used today in spacecraft and missiles, the more prosaic applications such as remote monitoring (via telemetry) of patients, water plants, highway conditions, etc. and the widespread use of computers far surpasses their space applications in quantity and variety of application.

Space is such an alien environment that attempting to work in it requires new techniques and knowledge. New technologies originating with or accelerated by space-related endeavors are often subsequently exploited in other economic activities. This has been widely pointed to as beneficial by space advocates and enthusiasts favoring the investment of public funds in space activities and programs. Political opponent<sup>1</sup> counter that it would be far cheaper to develop specific technologies directly if they are beneficial and scoff at this justification for public expenditures on space-related research.



After World War 2 the space technology have received the great progress and achieved a great success. But space technology are very expensive and have limited possibilities. In the beginning 21th century the researches of some revolutionary space technology started [1]-[22]. These new technology which promise to decrease the cost of a space exploration in hundreds times. Some of them are described in this review.

**Current status of new space technology and systems.** Over recent years interference-fit joining technology including the application of space methods has become important in the achievement of space propulsion system. Part results in the area of non-rocket space launch and flight methods have been patented recently or are patenting now.

Professor Bolonkin made a significant contribution to the study of the new revolutionary space technology in recent years [1]-[22] (1982-2011). Some of them are presented in given review.

Space Elevator, Transport System for Space Elevator is researched in [1] Ch.1; Men without the space suite into space is described in [1] Ch.19; Electrostatic levitation and Artificial gravity is investigated in [1] Ch.15; New method of atmospheric re-entry of space ship was studied in [2] Ch.8; Inflatable Dome for Moon, Mars, satellites, and space hotel is described [3] Ch2; AB method irrigation for planet without water (Closed loop water cycle) is studied in [3] Ch.1; Artificial explosion of the Sun was researched in [4] Ch.10.

Some of these systems were developed in [5]-[23].

Many useful ideas and innovations for space technologies in given field were presented in patent and patent application section of References. In particularly, there are:

Significant scientific, interplanetary and industrial use did not occur until the 20th century, when rocketry was the enabling technology of the Space Age, including setting foot on the Moon.

But rockets are very expensive and have limited possibilities. In the beginning 21th century the researches of new space technologies started [1]-[22].Some of them are described in this review.

## **Main types of Non-Rocket Space Propulsion System**

Contents:

1. Space Elevator, Transport System for Space Elevator
2. Men without the space suite into space,
3. Electrostatic levitation and Artificial gravity,
4. New method of atmospheric re-entry of space ship,
5. Inflatable Dome for Moon, Mars, satellites, and space hotel
6. Ab method irrigation for planet without water. (Closed loop water cycle),
7. Artificial explosion of the Sun.

### **1. Space Elevator, Transport System for Space Elevator\***

The reseach brings together research on the space elevator and a new transportation system for it. This transportation system uses mechanical energy transfer and requires only minimal energy so that it provides a “Free Trip” into space. It uses the rotary energy of planets. The research contains the theory and results of computations for the following projects: 1. Transport System for Space Elevator. The low cost project will accommodate 100,000 tourists annually. 2. Delivery System for Free Round Trip to Mars (for 2000 people annually). 3 Free Trips to the Moon (for 10,000 tourists annually).

The projects use artificial material like nanotubes and whiskers that have a ratio of strength to density equal to 4 million meters. At present scientific laboratories receive nanotubes that have this ratio equal to 20 million meters.

\* That part of the chapter was presented by author as paper IAC-02-V.P.07 at the World Space Congress-2002, Oct.10-19, Houston, TX, USA and published in *JBIS*, vol. 56, No. 7/8, 2003, pp. 231–249. See also Bolonkin A.A., (2005) "Non-Rocket Space Launch and Flight", Elsevier, 2005, Ch.1, <http://www.archive.org/details/Non-rocketSpaceLaunchAndFlight>, <http://www.scribd.com/doc/24056182>

## Free trip to Space (Project 1)

### Description

A proposed centrifugal space launcher with a cable transport system is shown in Fig.1-1. The system includes an equalizer (balance mass) located in geosynchronous orbit, an engine located on Earth, and the cable transport system having three cables: a main (central) cable of equal stress, and two transport cables, which include a set of mobile cable chains connected sequentially one to another by the rollers. One end of this set is connected to the equalizer, the other end is connected to the planet. Such a separation is necessary to decrease the weight of the transport cables, since the stress is variable along the cable. This transport system design requires a minimum weight because at every local distance the required amount of cable is only that of the diameter for the local force. The load containers are also connected to the chain. When containers come up to the rollers, they move past the rollers and continue their motion up the cable. The entire transport system is driven by any conventional motor located on the planet. When payloads are not being delivered into space, the system may be used to transfer mechanical energy to the equalizer (load cabin, the space station). This mechanical energy may also be converted to any other sort energy.

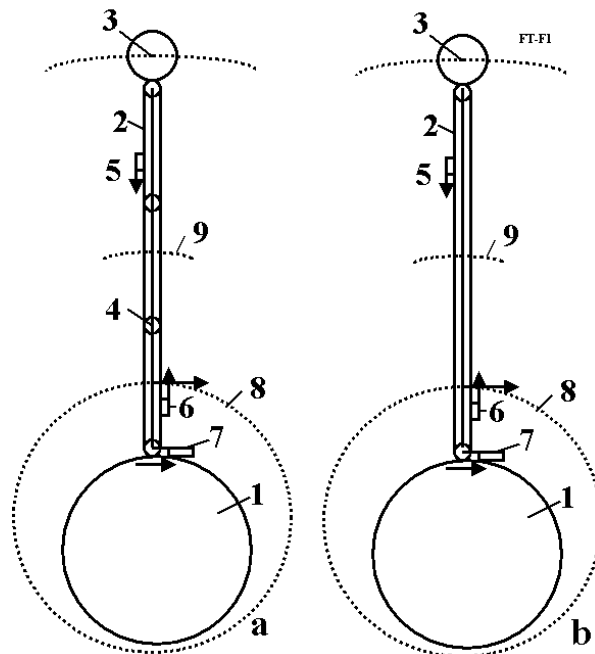


Fig. 1-1a,b. The suggested Space Transport System. Notations: 1 – Rotary planet (for example, the Earth); 2 - suggested Space Transport System ; 3 - equalizer (counterweight); 4 - roller of Transport System; 5 - launch space ship; 6 - a return ship after flight ; 7 – engine of Transport System; 8 – elliptic orbit of tourist vehicles; 9 - Geosynchronous orbit. *a* – System for low coefficient  $k$ , *b* – System for high coefficient  $k$  (without rollers 4).

The space satellites released below geosynchronous orbit will have elliptic orbits and may be connected back to the transport system after some revolutions when the space ship and cable are in the

same position (Fig.1- 1). If low earth orbit satellites use a brake parachute, they can have their orbit closed to a circle.

The space probes released higher than geosynchronous orbit will have a hyperbolic orbit, fly to other planets, and then can connect back to the transport system when the ship returns.

Most space payloads, like tourists, must be returned to Earth. When one container is moved up, then another container is moved down. The work of lifting equals the work of descent, except for a small loss in the upper and lower rollers. The suggested transport system lets us fly into space without expending enormous energy. This is the reason why the method and system are named a “Free Trip”.

Devices shown on fig. 1-2 are used to change the cable length (or chain length). The middle roller is shown in fig. 1-3.

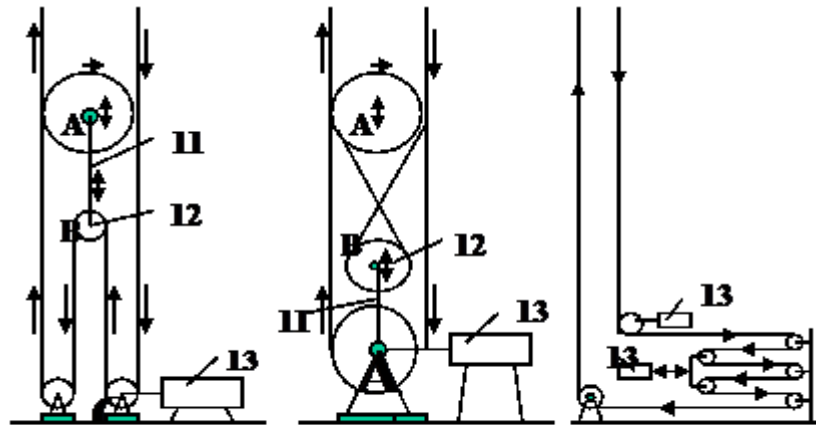


Fig. 1-2. Two mechanisms for changing the rope length in the Transport System (They are same for the space station). Notations: 11 - the rope which is connected axis  $A,B$ . This rope can change its length (the distance  $AB$ ); 12 - additional rollers.

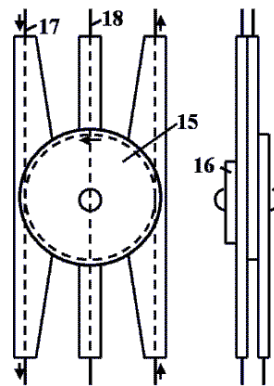


Fig. 1-3. Roller of Space Transport System. Notations: 15 – roller, 16 – control; 17 – transport system cable; 18 – main cable.

If the cable material has a very high ratio of safe (admissible) stress/density there may be one chain (Fig. 1-1b). The transport system then has only one main cable. Old design (fig. 1-1.1) has many problems, for example, in the transfer of large amounts of energy to the load cabin.

### Theory and Computation of optimal cable

(in metric system)

1. The cable of equal stress for the planet. The force active in the cable is:

$$F = \sigma A = F_0 + \int_{R_0}^R dW = F_0 + \int_{R_0}^R \gamma A dR \quad (1.1)$$

where

$$\gamma = \gamma_0 g_0 \left[ \left( \frac{R_0}{R} \right)^2 - \frac{\omega^2 R}{g_0} \right]. \quad (1.2)$$

$F$  is force, N;  $\sigma$  is tensile strength, N/m<sup>2</sup>;  $W$  – mass of cable, kg;  $\gamma$  – density of cable, kg/m<sup>3</sup>;  $A$  is cross-section area of cable, m<sup>2</sup>;  $R_0$  – radius of planet, m;  $R$  – radius, m;  $\omega$  – angle speed of planet, rad/sec;  $g$  – planet acceleration, m/s<sup>2</sup>; the lower index ‘<sub>o</sub>’ means data on planet surface.

If we substitute (1.2) in (1.1) and find the difference to the variable upper integral limit, we obtain the differential equations

$$\frac{1}{A} dA = \frac{\gamma_0 g_0}{\sigma} \left[ \left( \frac{R_0}{R} \right)^2 - \frac{\omega^2 R}{g_0} \right] dR. \quad (1.3)$$

Solution to equation (1.3) is

$$a(R) = \frac{A}{A_0} = \exp \left[ \frac{\gamma_0 g_0 B(R)}{\sigma} \right] \quad (1.4)$$

$$B(r) = R_0^2 \left\{ \left( \frac{1}{R_0} - \frac{1}{R} \right) - \frac{\omega^2}{2g_0} \left[ \left( \frac{R}{R_0} \right)^2 - 1 \right] \right\},$$

where  $a$  is the relative cable area,  $B(r)$  is the work of lifting 1 kg mass.

The computation for different  $K = \sigma/\gamma_0/10^7$  is presented in [1] Fig. 1.6.

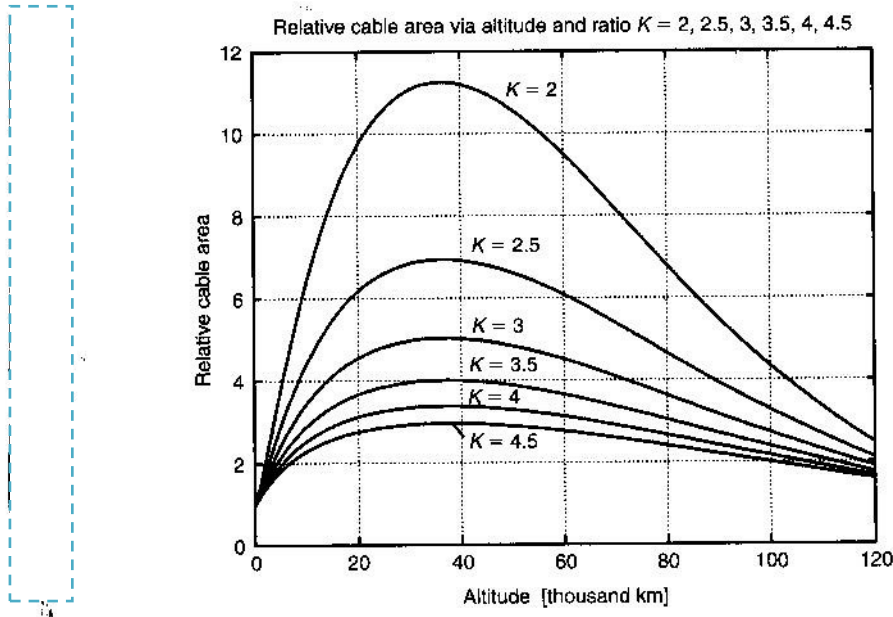
## Transport system for Space Elevator (Project 1)

That is an example of an inexpensive transport system for cheap annual delivery of 100,000 tourists, or 12,000 tons of payload into Earth orbits, or the delivery up to 2,000 tourists to Mars, or the launching of up to 2,500 tons of payload to other planets.

### Main results of computation

The suggested space transport system can be used for delivery of tourists and payloads to an orbit around the Earth, or to space stations serving as a tourist hotel, scientific laboratory, or industrial factory, or for the delivery of people and payloads to other planets.

Technical parameters: Let us take the safe cable stress 7200 kg/mm<sup>2</sup> and cable density 1800 kg/m<sup>3</sup>. This is equal to  $K = 4$ . This is not so great since by the year 2000 many laboratories had made experimental nanotubes with a tensile stress of 200 Giga-Pascals (20,000 kg/mm<sup>2</sup>) and a density of 1800 kg/m<sup>3</sup>. The theory of nanotubes predicts 100 ton/mm<sup>2</sup> with Young’s modulus of up to 5 Tera Pascal’s (currently it is 1 Tera Pascal) and a density of 800 kg/m<sup>3</sup> for SWNTs nanotubes. This means that the coefficient  $K$  used in our equations and graphs can be up to 125.



**Fig. 1.6.** Relative cable area via altitude [thousand km] for coefficient  $K = 2-4.5$ .

[1] Fig. 1.6.

Assume a maximum equalizer lift force of 9 tons at the Earth's surface and divide this force between three cables: one main and two transport cables. Then it follows from [1] Fig. 1.11, that the mass of the equalizer (or the space station) creates a lift force of 9 tons at the Earth's surface, which equals 518 tons for  $K = 4$  (this is close to the current International Space Station weight of 450 tons). The equalizer is located over a geosynchronous orbit at an altitude of 100,000 km. Full centrifugal lift force of the equalizer ([1] Fig. 1.10) is 34.6 tons, but 24.6 tons of the equalizer are used in support of the cables. The transport system has three cables: one main and two in the transport system. Each cable can support a force (load) of 3000 kgf. The main cable has a cross-sectional area of equal stress. Then the cable cross-section area is (see [1] Fig. 1.6)  $A = 0.42 \text{ mm}^2$  (diameter  $D = 0.73 \text{ mm}$ ) at the Earth's surface, maximum  $1.4 \text{ mm}^2$  in the middle section ( $D = 1.33 \text{ mm}$ , altitude 37,000 km), and  $A = 0.82 \text{ mm}^2$  ( $D = 1 \text{ mm}$ ) at the equalizer. The mass of main cable is 205 tons (see [1] Fig. 1.8). The chains of the two transport cable loops have gross section areas to equal the tensile stress of the main cable at given altitude, and the capabilities are the same as the main cable. Each of them can carry 3 tons force. The total mass of the cable is about 620 tons. The three cables increase the safety of the passengers. If any one of the cables breaks down, then the other two will allow a safe return of the space vehicle to Earth and the repair of the transport system.

If the container cable is broken, the pilot uses the main cable for delivering people back to Earth. If the main cable is broken, then the load container cable will be used for delivering a new main cable to the equalizer. For lifting non-balance loads (for example, satellites or parts of new space stations, transport installations, interplanetary ships), the energy must be spent in any delivery method. This energy can be calculated from equation [1] (1.8) (Fig. 1.15). When the transport system in Fig. 1-1 is used, the engine is located on the Earth and does not have an energy limitation [1]<sup>11</sup>. Moreover, the transport system in Fig. 1-1 can transfer a power of up to 90,000 kW to the space station for a cable speed of 3 km/s. At the present time, the International Space Station has only 60 kW of power.

Delivery capabilities. For tourist transportation the suggested system works in the following manner. The passenger space vehicle has the full mass of 3 tons (6667 pounds) to carry 25 passengers and two pilots. One ship moves up, the other ship, which is returning, moves down; then the lift and descent energies are approximately equal. If the average speed is 3 km/s then the first ship reaches the altitude of 21.5 – 23 thousands km in 2 hours (acceleration  $1.9 \text{ m/s}^2$ ). At this altitude the ship is separated from

the cable to fly in an elliptical orbit with minimum altitude 200 km and period approximately 6 hours ([1] Figs. 1.16, 1.17). After one day the ship makes four revolutions around the Earth while the cable system makes one revolution, and the ship and cable will be in the same place with the same speed. The ship is connected back to the transport system, moves down the cable and lifts the next ship. The orbit may be also 3 revolutions (period 8 hours) or 2 revolutions (period 12 hours). In one day the transport system can accommodate 12 space ships (300 tourists) in both directions. This means more than 100,000 tourists annually into space.

The system can launch payloads into space, and if the altitude of disconnection is changed then the orbit is changed (see [1] Fig. 1.17). If a satellite needs a low orbit, then it can use the brike parachute when it flies through the top of the atmosphere and it will achieve a near circular orbit. The annual payload capability of the suggested space transport system is about 12,600 tons into a geosynchronous orbit.

If instead of the equalizer the system has a space station of the same mass at an altitude of 100,000 km and the system can has space stations along cable and above geosynchronous orbit then these stations decrease the mass of the equalizer and may serve as tourist hotels, scientific laboratories, or industrial factories.

If the space station is located at an altitude of 100,000 km, then the time of delivery will be 9.36 hours for an average delivery speed of 3 km/s. This means 60 passengers per day or 21,000 people annually in space.

Let us assume that every person needs 400 kg of food for a one-year round trip to Mars, and Mars has the same transport installation (see next project). This means we can send about 2000 people to Mars annually at suitable positions of Earth relative to Mars.

### **Estimations of installation cost and production cost of delivery**

Cost of suggested space transport installation [1]<sup>5,6</sup>. The current International Space Station has cost many billions of dollars, but the suggested space transport system can cost a lot less. Moreover, the suggested transport system allows us to create other transport systems in a geometric progression [see equation [1](1.13)]. Let us examine an example of the transport system.

Initially we create the transport system to lift only 50 kg of load mass to an altitude of 100,000 km. Using the [1] Figs. 1.6 to 1.14 we have found that the equalizer mass is 8.5 tons, the cable mass is 10.25 tons and the total mass is about 19 tons. Let us assume that the delivery cost of 1 kg mass is \$10,000. The construction of the system will then have a cost of \$190 million. Let us assume that 1 ton of cable with  $K = 4$  from whiskers or nanotubes costs \$0.1 million then the system costs \$1.25 million. Let us put the research and development (R&D) cost of installation at \$29 million. Then the total cost of initial installation will be \$220 million. About 90% of this sum is the cost of initial rocket delivery.

After construction, this initial installation begins to deliver the cable and equalizer or parts of the space station into space. The cable and equalizer capability increase in a geometric progression. The installation can use part of the time for delivery of payload (satellites) and self-financing of this project. After 765 working days the total mass of equalizer and cables reaches the amount above (1133 tons) and the installation can work full time as a tourist launcher or continue to create new installations. In the last case this installation and its derivative installations can build 100 additional installations (1133 tons) in only 30 months [see equation [1] (1.13) and Fig. 1.21] with a total capability of 10 million tourists per year. The new installations will be separated from the mother installations and moved to other positions around the Earth. The result of these installations allows the delivery of passengers and payloads from one continent to another across space with low expenditure of energy.

Let us estimate the cost of the initial installation. The installation needs 620 tons of cable. Let us take the cost of cable as \$0.1 million per ton. The cable cost will be \$62 million. Assume the space station cost \$20 million. The construction time is 140 days [equation (1.13)]. The cost of using of the mother installation without profit is \$5 millions/year. In this case the new installation will cost \$87 million. In reality the new installation can soon after construction begin to launch payloads and become self-financing.

### Cost of delivery

The cost of delivery is the most important parameter in the space industry. Let us estimate it for the full initial installation above.

As we calculated earlier the cost of the initial installation is \$220 millions (further construction is made by self-financing). Assume that installation is used for 20 years, served by 100 officers with an average annual salary of \$50,000 and maintenance is \$1 million in year. If we deliver 100,000 tourists annually, the production delivery cost will be \$160/person or \$1.27/kg of payload. Some 70% of this sum is the cost of installation, but the delivery cost of the new installations will be cheaper.

If the price of a space trip is \$1990, then the profit will be \$183 million annually. If the payload delivery price is \$15/kg then the profit will \$189 millions annually.

The cable speed for  $K = 4$  is 6.32 km/s [equation [1] (1.11), Fig. 1.19]. If average cable speed equals 6 km/s, then all performance factors are improved by a factor of two times.

If the reader does not agree with this estimation, then equations [1] (1.1) to (1.13) and Figs. 1.6 to 1.21 are able calculation of the delivery cost for other parameters. In any case the delivery cost will be hundreds of times less than the current rocket powered method.

## Delivery System for Free Round Trip to Mars (Project 2)

A method and similar installation Fig.1-1, [1](Figs.1 to 4) can be used for inexpensive travel to other planets, for example, from the Earth to Mars or the Moon and back [1](Fig. 1.22). A Mars space station would be similar to an Earth space station, but the Mars station would weigh less due to the decreased gravitation on Mars. This method uses the rotary energy of the planets. For this method, two facilities are required, one on Earth and the other on another planet (e.g. Mars). The Earth accelerates the space ship to the required speed and direction and then disconnects the ship. The space ship flies in space along the defined trajectory to Mars (Fig.1-4). On reaching Mars the space ship connects to the cable of the Mars space transport system, then it moves down to Mars using the transport system.

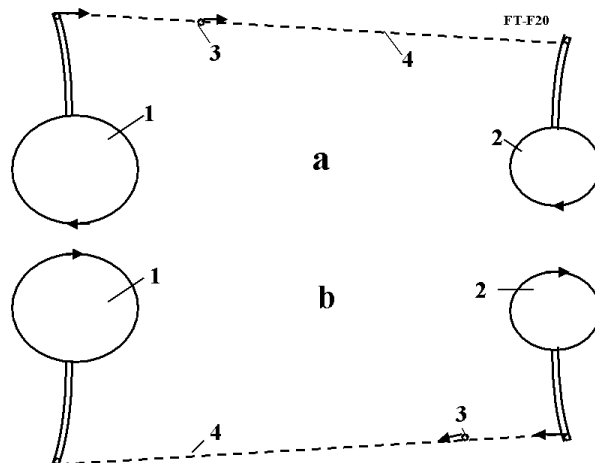


Fig. 1-4. Using the suggested transport system for space flight to Mars and back. Notation: 1 – Earth, 2 – Mars, 3 – space ship, 4 – trajectory of space ship to Mars (a) and back (b).



### Free Trip to Moon (Project 3)

This method may be used for an inexpensive trip to a planet's moon, if the moon's angular speed is equal to the planet's angular speed, for example, from the Earth to the Moon and back (Fig. 1-5 to 1-7). The upper end of the cable is connected to the planet's moon. The lower end of the cable is connected to an aircraft (or buoy), which flies (i.e. glides or slides) along the planet's surface. The lower end may be also connected to an Earth pole. The aircraft (or Earth polar station, or Moon) has a device which allows the length of cable to be changed. This device would consist of a spool, motor, brake, transmission, and controller. The facility could have devices for delivering people and payloads to the Moon and back using the suggested transport system. The delivery devices include: containers, cables, motors, brakes, and controllers. If the aircraft is small and the cable is strong then the motion of the Moon can be used to move the airplane. For example, if the airplane weighs 15 tons and has an aerodynamic ratio (the lift force to the drag force) equal to 5, a thrust of 3000 kg would be enough for the aircraft to fly for infinity without requiring any fuel. The aircraft could use a small engine for maneuverability and temporary landing. If the planet has an atmosphere (as the Earth) the engine could be a turbine engine. If the planet does not have an atmosphere, a rocket engine may be used.

If the suggested transport system is used only for free thrust (9 tons), the system can thrust the three named supersonic aircraft or produce up to 40 millions watts of energy.

A different facility could use a transitional space station located at the zero gravity point between the planet and the planet's moon. Fig. 6 shows a sketch of the temporary landing of an airplane on the planet surface. The aircraft increases the length of the cable, flies ahead of the cable, and lands on a planet surface. While the planet makes an angle turn ( $\alpha + \beta = 30^\circ$ , see Fig. 1.31) the aircraft can be on a planet surface. This time equals about 2 hours for the Earth, which would be long enough to load payload on the aircraft.

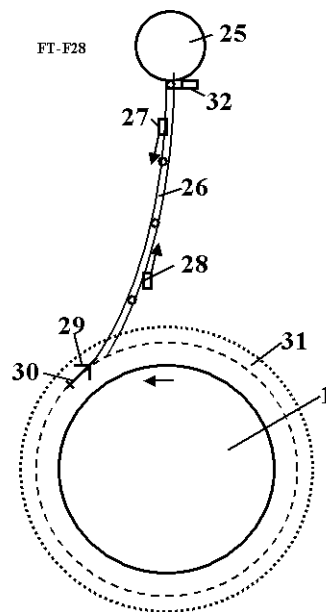


Fig.1- 5. The suggested transport system for the Moon. Notations: 1 – Earth, 25 - Moon, 26 – suggested Moon transport system, 27, 28 – load cabins, 29 – aircraft, 30 – cable control, 32 – engine.

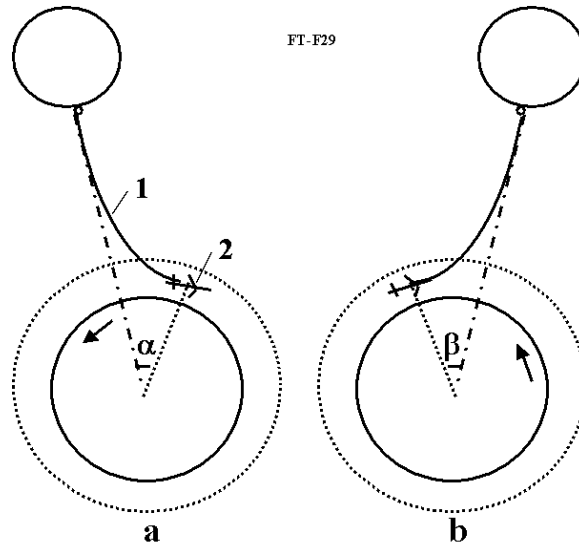


Fig.1- 6. Temporary landing of the Moon aircraft on the Earth's surface for loading. a– landing, b– take-off.

The Moon's trajectory has an eccentricity (Fig.1-7). If the main cable is strong enough, the moon may used to pull a payload (space ship, manned cabin), by trajectory to an altitude of about 60,000 kilometers every 27 days. For this case, the length of the main cable from the Moon to the container does not change and when the Moon increases its distance from the Earth, the Moon lifts the space ship. The payload could land back on the planet at any time if it is allowed to slide along the cable. The Moon's energy can be used also for an inexpensive trip around the Earth (Figs. 1-5 and 1-7) by having the moon "drag" an aircraft around the planet (using the Moon as a free thrust engine). The Moon tows the aircraft by the cable at supersonic speed, about 440 m/s (Mach number is 1.5).

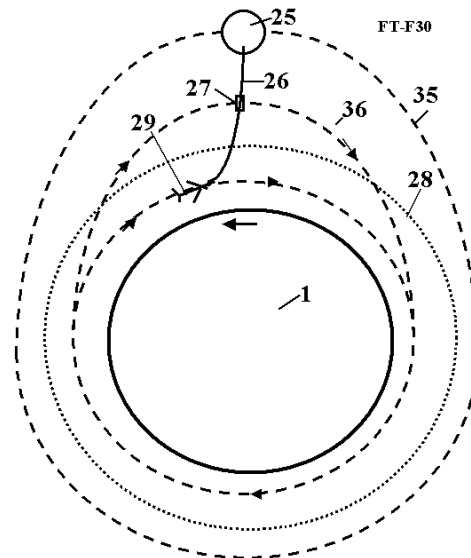


Fig. 1-7. Using the Moon's elliptical orbit for a free trip in space of up to 71,000 km. Notations: 1 – Earth, 25 – Moon, 26 – cable from Earth to Moon, 27 – Space Vehicle, 28 – limit of Earth atmosphere, 35 – Moon orbit, 36 – elliptical orbit of a Moon vehicle.

The other more simple design (without aircraft) is shown in [1] Fig. 7.1, chapter 7. The cable is

connected to on Earth pole, to a special polar station which allows to change a length of cable. Near the pole the cable is supported in the atmosphere by air balloons and wings.

### Technical parameters

The following are some data for estimating the main transport system parameters for connecting to the Moon to provide inexpensive payload transfer between the Earth and the Moon. The system has three cables, each of which can keep the force at 3 tons. Material of the cable has  $K=4$ . All cables would have cross-sectional areas of equal stress. The cable has a minimal cross-sectional area  $A_0$  of 0.42 mm<sup>2</sup> (diameter  $d = 0.73$  mm) and maximum cross-sectional area  $A_m$  of 1.9 mm<sup>2</sup> ( $d = 1.56$  mm). The mass of the main cable would be 1300 tons [1] (Fig. 1.36). The total mass of the main cable plus the two container cables (for delivering a mass of 3000 kg) equals 3900 tons for the delivery transport system in [1] Figs. 1.30 to 1.33. An inexpensive means of payload delivery between the Earth and the Moon could thus be developed. The elapsed time for the Moon trip at a speed of 6 km/s would be about 18.5 hours and the annual delivery capability would be 1320 tons in both directions.

### Discussion Cable Problems

Most engineers and scientists think it is impossible to develop an inexpensive means to orbit to another planet. Twenty years ago, the mass of the required cable would not allow this proposal to be possible for an additional speed of more 2,000 m/s from one asteroid. However, today's industry widely produces artificial fibers that have a tensile strength 3–5 times more than steel and a density 4–5 times less than steel. There are also experimental fibers which have a tensile strength 30–60 times more than steel and a density 2 to 4 times less than steel. For example, in the book *Advanced Fibers and Composites* is p. 158, there is a fiber  $C_D$  with a tensile strength of  $\sigma = 8000$  kg/mm<sup>2</sup> and density (specific gravity)  $\gamma = 3.5$  g/cm<sup>3</sup>. If we take an admitted strength of 7000 kg/mm<sup>2</sup> ( $\sigma = 7 \times 10^{10}$  N/m<sup>2</sup>,  $\gamma = 3500$  kg/m<sup>3</sup>) then the ratio,  $\sigma/\gamma = 0.05 \times 10^{-6}$  or  $\sigma/\gamma = 20 \times 10^6$  ( $K = 2$ ). Although (in 1976) the graphite fibers are strong ( $\sigma/\gamma = 10 \times 10^6$ ), they are at best still ten times weaker than theory predicts.

Steel fiber has tensile strengths of 5,000 MPa (500 kg/mm<sup>2</sup>), but the theoretic value is 22,000 MPa (1987). Polyethylene fiber has a tensile strength of 20,000 MPa and the theoretical value is 35,000 MPa (1987).

The mechanical behavior of nanotubes also has provided excitement because nanotubes are seen as the ultimate carbon fiber, which can be used as reinforcements in advanced composite technology. Early theoretical work and recent experiments on individual nanotubes (mostly MWNTs) have confirmed that nanotubes are one of the stiffest materials ever made. Whereas carbon–carbon covalent bonds are one of the strongest in nature, a structure based on a perfect arrangement of these bonds oriented along the axis of nanotubes would produce an exceedingly strong material. Traditional carbon fibers show high strength and stiffness, but fall far short of the theoretical in-plane strength of graphite layers (an order of magnitude lower). Nanotubes come close to being the best fiber that can be made from graphite structure.

For example, whiskers made from carbon nanotubes (CNT) have a tensile strength of 200 Giga-Pascals and Young's modulus of over 1 Tera Pascal (1999). The theory predicts 1 Tera Pascal and Young modulus 1–5 Tera Pascals. The hollow structure of nanotubes makes them very light (specific density varies from 0.8 g/cc for SWNTs up to 1.8 g/cc for MWNTs, compared to 2.26 g/cc for graphite or 7.8 g/cc for steel).

Specific strength (strength/density) is important in the design of our transportation system and space elevator; nanotubes have this value at least 2 orders of magnitude greater than steel. Traditional carbon fibers have a specific strength 40 times greater than steel. Where nanotubes are made of graphite carbon, they have good resistance to chemical attack and have high terminal stability. Oxidation

studies have shown that the onset of oxidation shifts by about 100 °C higher temperatures in nanotubes compared to high modulus graphite fibers. In vacuums or reducing atmospheres, nanotubes structures will be stable at any practical service temperature. Nanotubes have excellent conductivity like copper.

The price for the SiC whiskers produced by Carborundun Co. with  $\sigma = 20,690$  MPa,  $\gamma = 3.22$  g/cc was \$440/kg in 1989. Medicine, the environment, space, aviation, machine-building, and the computer industry need cheap nanotubes. Some American companies plan to produce nanotubes in 2–3 years.

Below the author provides a brief overview of the annual research information (2000) regarding the proposed experimental test fibers.

### Data that can be used for computation

Let us consider the following experimental and industrial fibers, whiskers, and nanotubes:

- Experimental nanotubes CNT (carbon nanotubes) have a tensile strength of 200 Giga-Pascals (20,000 kg/mm<sup>2</sup>), Young's modulus is over 1 Tera Pascal, specific density  $\gamma = 1800$  kg/m<sup>3</sup> (1.8 g/cc) (year 2000).  
For safety factor  $n = 2.4$ ,  $\sigma = 8300$  kg/mm<sup>2</sup> =  $8.3 \times 10^{10}$  N/m<sup>2</sup>,  $\gamma = 1800$  kg/m<sup>3</sup>,  $(\sigma/\gamma) = 46 \times 10^6$ ,  $K = 4.6$ . The SWNTs nanotubes have a density of 0.8 g/cc, and MWNTs have a density of 1.8 g/cc. Unfortunately, the nanotubes are very expensive at the present time (1994).
- For whiskers  $C_D$   $\sigma = 8000$  kg/mm<sup>2</sup>,  $\gamma = 3500$  kg/m<sup>3</sup> (1989) [p.158]<sup>7</sup>.
- For industrial fibers  $\sigma = 500 - 600$  kg/mm<sup>2</sup>,  $\gamma = 1800$  kg/m<sup>3</sup>,  $\sigma/\gamma = 2,78 \times 10^6$ ,  $K = 0.278 - 0.333$ , Figures for some other experimental whiskers and industrial fibers are give in Table 1.2.

Table 1.2

Material	Tensile strength kg/mm <sup>2</sup>	Density Fibers g/cc		MPa	Density g/cc
Whiskers					
AlB <sub>12</sub>	2650	2.6	QC-8805	6200	1.95
B	2500	2.3	TM9	6000	1.79
B <sub>4</sub> C	2800	2.5	Thorael	5650	1.81
TiB <sub>2</sub>	3370	4.5	Allien 1	5800	1.56
SiC	1380–4140	3.22	Allien 2	3000	0.97

See References <sup>7,8,9,10</sup> in [1] Ch.1.

## Conclusions

The new materials make the suggested transport system and projects highly realistic for a free trip to outer space without expention of energy. The same idea was used in the research and calculation of other revolutionary innovations such as launches into space without rockets (not space elevator, not gun); cheap delivery of loads from one continent to another across space; cheap delivery of fuel gas over long distances without steel tubes and damage to the environment; low cost delivery of large load flows across sea streams and mountains without bridges or underwater tunnels [Gibraltar, English Channel, Bering Stream (USA–Russia), Russia–Sakhalin–Japan, etc.]; new economical transportation systems; obtaining inexpensive energy from air streams at high altitudes; etc. some of these are in reference [1]<sup>12–21</sup> Ch.1.

The author has developed innovations, estimations, and computations for the above mentioned problems. Even though these projects seem impossible for the current technology, the author is prepared to discuss the project details with serious organizations that have similar research and development goals.

## 2. Man in Space without Space Suite\*

The author proposes and investigates his old idea - a living human in space without the encumbrance of a complex space suit. Only in this condition can biological humanity seriously attempt to colonize space because all planets of Solar system (except the Earth) do not have suitable atmospheres. Aside from the issue of temperature, a suitable partial pressure of oxygen is lacking. In this case the main problem is how to satiate human blood with oxygen and delete carbonic acid gas (carbon dioxide). The proposed system would enable a person to function in outer space without a space suit and, for a long time, without food. That is useful also in the Earth for sustaining working men in an otherwise deadly atmosphere laden with lethal particulates (in case of nuclear, chemical or biological war), in underground confined spaces without fresh air, under water or a top high mountains above a height that can sustain respiration.

-----  
 \* Published in [1] Ch.19; in [4] Ch.6.

### Introduction

**Short history.** A fictional treatment of Man in space without spacesuit protection was famously treated by Arthur C. Clarke in at least two of his works, "Earthlight" and the more famous "2001: A Space Odyssey". In the scientific literature, the idea of sojourning in space without complex space suits was considered seriously about 1970 and an initial research was published in [1] p.335 – 336. Here is more detail research this possibility.

**Humans and vacuum.** Vacuum is primarily an asphyxiant. Humans exposed to vacuum will lose consciousness after a few seconds and die within minutes, but the symptoms are not nearly as graphic as commonly shown in pop culture. Robert Boyle was the first to show that vacuum is lethal to small animals. Blood and other body fluids do boil (the medical term for this condition is ebullism), and the vapour pressure may bloat the body to twice its normal size and slow circulation, but tissues are elastic and porous enough to prevent rupture. Ebullism is slowed by the pressure containment of blood vessels, so some blood remains liquid. Swelling and ebullism can be reduced by containment in a flight suit. Shuttle astronauts wear a fitted elastic garment called the Crew Altitude Protection Suit (CAPS) which prevents ebullism at pressures as low as 15 Torr (2 kPa). However, even if ebullism is prevented, simple evaporation of blood can cause decompression sickness and gas embolisms. Rapid evaporative cooling of the skin will create frost, particularly in the mouth, but this is not a significant hazard.

Animal experiments show that rapid and complete recovery is the norm for exposures of fewer than 90 seconds, while longer full-body exposures are fatal and resuscitation has never been successful.<sup>[4]</sup> There is only a limited amount of data available from human accidents, but it is consistent with animal data. Limbs may be exposed for much longer if breathing is not impaired. Rapid decompression can be much more dangerous than vacuum exposure itself. If the victim holds his breath during decompression, the delicate internal structures of the lungs can be ruptured, causing death. Eardrums may be ruptured by rapid decompression, soft tissues may bruise and seep blood, and the stress of shock will accelerate oxygen consumption leading to asphyxiation.

In 1942, the Nazi regime tortured Dachau concentration camp prisoners by exposing them to vacuum. This was an experiment for the benefit of the German Air Force (Luftwaffe), to determine the human body's capacity to survive high altitude conditions.

Some extremophile microorganisms, such as Tardigrades, can survive vacuum for a period of years.

**Respiration (physiology).** In animal physiology, respiration is the transport of oxygen from the clean air to the tissue cells and the transport of carbon dioxide in the opposite direction. This is in contrast to

the biochemical definition of respiration, which refers to cellular respiration: the metabolic process by which an organism obtains energy by reacting oxygen with glucose to give water, carbon dioxide and ATP (energy). Although physiologic respiration is necessary to sustain cellular respiration and thus life in animals, the processes are distinct: cellular respiration takes place in individual cells of the animal, while physiologic respiration concerns the bulk flow and transport of metabolites between the organism and external environment.

In unicellular organisms, simple diffusion is sufficient for gas exchange: every cell is constantly bathed in the external environment, with only a short distance for gases to flow across. In contrast, complex multicellular organisms such as humans have a much greater distance between the environment and their innermost cells, thus, a respiratory system is needed for effective gas exchange. The respiratory system works in concert with a circulatory system to carry gases to and from the tissues.

In air-breathing vertebrates such as humans, respiration of oxygen includes four stages:

- *Ventilation* from the ambient air into the alveoli of the lung.
- *Pulmonary gas exchange* from the alveoli into the pulmonary capillaries.
- *Gas transport* from the pulmonary capillaries through the circulation to the peripheral capillaries in the organs.
- *Peripheral gas exchange* from the tissue capillaries into the cells and mitochondria.

Note that ventilation and gas transport require energy to power mechanical pumps (the diaphragm and heart respectively), in contrast to the passive diffusion taking place in the gas exchange steps.

Respiratory physiology is the branch of human physiology concerned with respiration.

**Respiration system.** In humans and other mammals, the respiratory system consists of the airways, the lungs, and the respiratory muscles that mediate the movement of air into and out of the body. Within the alveolar system of the lungs, molecules of oxygen and carbon dioxide are passively exchanged, by diffusion, between the gaseous environment and the blood. Thus, the respiratory system facilitates oxygenation of the blood with a concomitant removal of carbon dioxide and other gaseous metabolic wastes from the circulation. The system also helps to maintain the acid-base balance of the body through the efficient removal of carbon dioxide from the blood.

**Circulation.** The right side of the heart pumps blood from the right ventricle through the pulmonary semilunar valve into the pulmonary trunk. The trunk branches into right and left pulmonary arteries to the pulmonary blood vessels. The vessels generally accompany the airways and also undergo numerous branchings. Once the gas exchange process is complete in the pulmonary capillaries, blood is returned to the left side of the heart through four pulmonary veins, two from each side. The pulmonary circulation has a very low resistance, due to the short distance within the lungs, compared to the systemic circulation, and for this reason, all the pressures within the pulmonary blood vessels are normally low as compared to the pressure of the systemic circulation loop.

Virtually all the body's blood travels through the lungs every minute. The lungs add and remove many chemical messengers from the blood as it flows through pulmonary capillary bed. The fine capillaries also trap blood clots that have formed in systemic veins.

**Gas exchange.** The major function of the respiratory system is gas exchange. As gas exchange occurs, the acid-base balance of the body is maintained as part of homeostasis. If proper ventilation is not maintained, two opposing conditions could occur: 1) respiratory acidosis, a life threatening condition, and 2) respiratory alkalosis.

Upon inhalation, gas exchange occurs at the alveoli, the tiny sacs which are the basic functional component of the lungs. The alveolar walls are extremely thin (approx. 0.2 micrometres), and are permeable to gases. The alveoli are lined with pulmonary capillaries, the walls of which are also thin enough to permit gas exchange.

**Membrane oxygenator.** A membrane oxygenator is a device used to add oxygen to, and remove carbon dioxide from the blood. It can be used in two principal modes: to imitate the function of the lungs in cardiopulmonary bypass (CPB), and to oxygenate blood in longer term life support, termed Extracorporeal membrane oxygenation, ECMO. A membrane oxygenator consists of a thin gas permeable membrane separating the blood and gas flows in the CPB circuit; oxygen diffuses from the gas side into the blood, and carbon dioxide diffuses from the blood into the gas for disposal.

The introduction of microporous hollow fibres with very low resistance to mass transfer revolutionised design of membrane modules, as the limiting factor to oxygenator performance became the blood resistance [Gaylor, 1988]. Current designs of oxygenator typically use an extraluminal flow regime, where the blood flows outside the gas filled hollow fibres, for short term life support, while only the homogeneous membranes are approved for long term use.

**Heart-lung machine.** The heart-lung machine is a mechanical pump that maintains a patient's blood circulation and oxygenation during heart surgery by diverting blood from the venous system, directing it through tubing into an artificial lung (oxygenator), and returning it to the body. The oxygenator removes carbon dioxide and adds oxygen to the blood that is pumped into the arterial system.

**Space suit.** A space suit is a complex system of garments, equipment and environmental systems designed to keep a person alive and comfortable in the harsh environment of outer space. This applies to extra-vehicular activity (EVA) outside spacecraft orbiting Earth and has applied to walking, and riding the Lunar Rover, on the Moon.

Some of these requirements also apply to pressure suits worn for other specialized tasks, such as high-altitude reconnaissance flight. Above Armstrong's Line (~63,000 ft/~19,000 m), pressurized suits are needed in the sparse atmosphere. Hazmat suits that superficially resemble space suits are sometimes used when dealing with biological hazards.

A conventional space suit must perform several functions to allow its occupant to work safely and comfortably. It must provide: A stable internal pressure, Mobility, Breathable oxygen, Temperature regulation, Means to recharge and discharge gases and liquids, Means of collecting and containing solid and liquid waste, Means to maneuver, dock, release, and/or tether onto spacecraft.

**Operating pressure.** Generally, to supply enough oxygen for respiration, a spacesuit using pure oxygen must have a pressure of about 4.7 psi (32.4 kPa), equal to the 3 psi (20.7 kPa) partial pressure of oxygen in the Earth's atmosphere at sea level, plus 40 torr (5.3 kPa) CO<sub>2</sub> and 47 torr (6.3 kPa) water vapor pressure, both of which must be subtracted from the alveolar pressure to get alveolar oxygen partial pressure in 100% oxygen atmospheres, by the alveolar gas equation. The latter two figures add to 87 torr (11.6 kPa, 1.7 psi), which is why many modern spacesuits do not use 3 psi, but 4.7 psi (this is a slight overcorrection, as alveolar partial pressures at sea level are not a full 3 psi, but a bit less). In spacesuits that use 3 psi, the astronaut gets only  $3 - 1.7 = 1.3$  psi (9 kPa) of oxygen, which is about the alveolar oxygen partial pressure attained at an altitude of 6100 ft (1860 m) above sea level. This is about 78% of normal sea level pressure, about the same as pressure in a commercial passenger jet aircraft, and is the realistic lower limit for safe ordinary space suit pressurization which allows reasonable work capacity.

Movements are seriously restricted in the suits, with a mass of more than 110 kilograms each (Shenzhou 7 space suit). The current space suits are very expensive. Flight-rated NASA spacesuits cost



about \$22,000,000. While other models may be cheaper, sale is not currently open even to the wealthy public. Even if spaceflight were free (a huge if) a person of average means could not afford to walk in space or upon other planets.

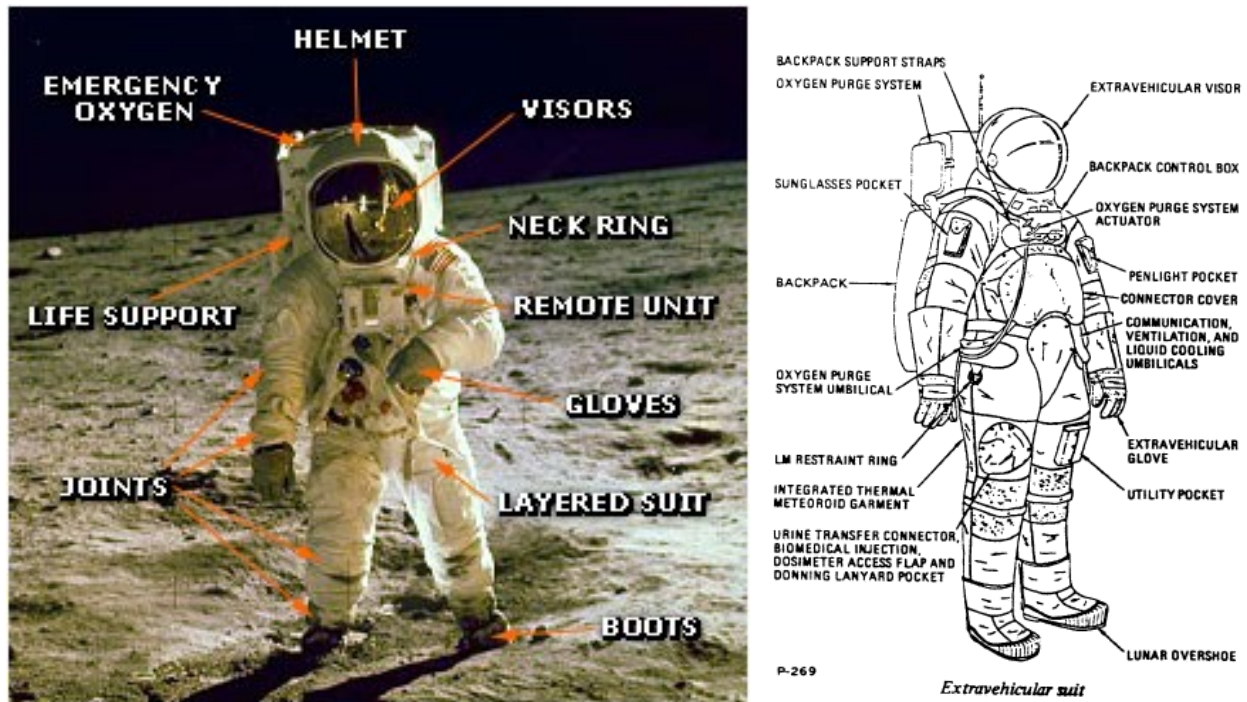


Fig. 2-1. a. Apollo 11 A7L space suit. b. Diagram showing component parts of A7L space suit.

### Brief Description of Innovation

A space suit is a very complex and expensive device (Fig. 2-1). Its function is to support the person's life, but it makes an astronaut immobile and slow, prevents him or her working, creates discomfort, does not allow eating in space, have a toilet, etc. Astronauts need a space ship or special space habitat located not far from away where they can undress for eating, toilet activities, and rest.

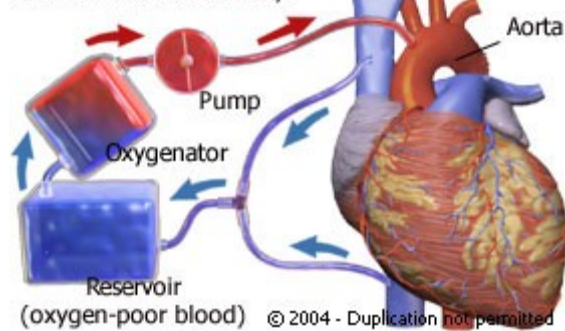
Why do we need a special space suit in outer space? There is only one reason – we need an oxygen atmosphere for breathing, respiration. Human evolution created lungs that aerates the blood with oxygen and remove carbon dioxide. However we can also do that using artificial apparatus. For example, doctors, performing surgery on someone's heart or lungs connect the patient to a heart – lung machine that acts in place of the patient's lungs or heart.

We can design a small device that will aerate the blood with oxygen and remove the carbon dioxide. If a tube from the main lung arteries could be connected to this device, we could turn on (off) the artificial breathing at any time and enable the person to breathe in a vacuum (on an asteroid or planet without atmosphere) in a degraded or poisonous atmosphere, or under water, for a long time. In space we can use a conventional Earth manufacture oversuit (reminiscent of those used by workers in semiconductor fabs) to protect us against solar ultraviolet light.

The sketch of device which saturates the blood with oxygen and removes the carbon dioxide is presented in fig.2-2. The Heart-Lung machines are widely used in current surgery.

### Heart-Lung Machine

Pump returns oxygenated blood to the aorta, which delivers it to the rest of the body.

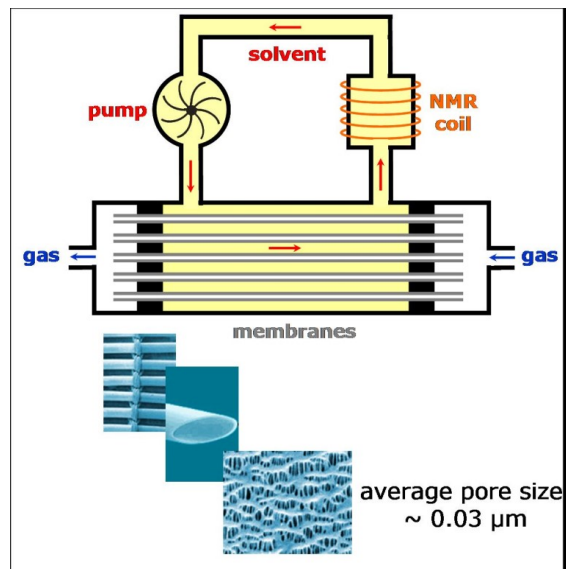


**Fig.2-2.** Principal sketch of heart-Lung Machine

The main part of this device is oxygenator, which aerates the blood with oxygen and removes the carbon dioxide. The principal sketch of typical oxygenator is presented in fig. 2-3.

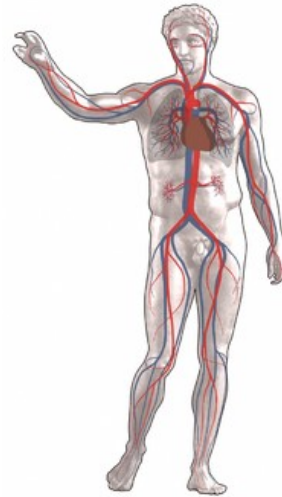
The **circulatory system** is an organ system that moves nutrients, gases, and wastes to and from cells, helps fight diseases and helps stabilize body temperature and pH to maintain homeostasis. This system may be seen strictly as a blood distribution network, but some consider the circulatory system as composed of the cardiovascular system, which distributes blood, and the lymphatic system, which distributes lymph. While humans, as well as other vertebrates, have a closed cardiovascular system (meaning that the blood never leaves the network of arteries, veins and capillaries), some invertebrate groups have an open cardiovascular system. The most primitive animal phyla lack circulatory systems. The lymphatic system, on the other hand, is an open system.

The human blood circulatory system is shown in Fig. 2-5.



**Fig.2-3.** Principal sketch of oxygenator.

Current oxygenator is shown in Fig. 2-4.



**Fig. 2-4.** (Left). Oxygenators.

**Fig.2-5.** (Right). The human circulatory system. Red indicates oxygenated blood, blue indicates deoxygenated.

The main components of the human circulatory system are the heart, the blood, and the blood vessels. The circulatory system includes: the pulmonary circulation, a "loop" through the [lungs](#) where blood is oxygenated; and the systemic circulation, a "loop" through the rest of the body to provide oxygenated blood. An average adult contains five to six quarts (roughly 4.7 to 5.7 liters) of blood, which consists of plasma that contains red blood cells, white blood cells, and platelets.

Two types of fluids move through the circulatory system: blood and lymph. The blood, heart, and blood vessels form the cardiovascular system. The lymph, lymph nodes, and lymph vessels form the lymphatic system. The cardiovascular system and the lymphatic system collectively make up the circulatory system.

The simplest form of intravenous access is a syringe with an attached **hollow needle**. The needle is inserted through the skin into a vein, and the contents of the syringe are injected through the needle into the bloodstream. This is most easily done with an arm vein, especially one of the metacarpal veins. Usually it is necessary to use a constricting band first to make the vein bulge; once the needle is in place, it is common to draw back slightly on the syringe to aspirate blood, thus verifying that the needle is really in a vein; then the constricting band is removed before injecting.

When man does not use the outer air pressure in conventional space suite, he not has opposed internal pressure except the heart small pressure in blood. The skin vapor easy stop by film clothes or make small by conventional clothes.

The current lung devices must be re-designed for space application. These must be small, light, cheap, easy in application (using hollow needles, no operation (surgery)!), work a long time in field conditions. Wide-ranging space colonization by biological humanity is impossible without them.

### **Artificial Nutrition.**

Application of offered devices gives humanity a unique possibility to be a long time without conventional nutrition. Many will ask, "who would want to live like that?" But in fact many crew members, military, and other pressured personnel routinely cut short what most would consider normal dining routines. And there are those morbidly obese people for whom dieting is difficult exactly because (in an unfortunate phrase!) many can give up smoking 'cold turkey', but few can give up 'eating cold turkey'! Properly 'fed' intravenously, a person could lose any amount of excess weight he

needed to, while not suffering hunger pains or the problems the conventional eating cycle causes. It is known that people in a coma may exist some years in artificial nutrition inserted into blood. Let us consider the current state of the art.

**Total parenteral nutrition (TPN)**, is the practice of feeding a person intravenously, bypassing the usual process of eating and digestion. The person receives nutritional formulas containing [salts](#), glucose, amino acids, lipids and added vitamins.

Total parenteral nutrition (TPN), also referred to as Parenteral nutrition (PN), is provided when the gastrointestinal tract is nonfunctional because of an interruption in its continuity or because its absorptive capacity is impaired. It has been used for comatose patients, although enteral feeding is usually preferable, and less prone to complications. Short-term TPN may be used if a person's digestive system has shut down (for instance by Peritonitis), and they are at a low enough weight to cause concerns about nutrition during an extended hospital stay. Long-term TPN is occasionally used to treat people suffering the extended consequences of an accident or surgery. Most controversially, TPN has extended the life of a small number of children born with nonexistent or severely deformed guts. The oldest were eight years old in 2003.

The preferred method of delivering TPN is with a medical infusion pump. A sterile bag of nutrient solution, between 500 mL and 4 L is provided. The pump infuses a small amount (0.1 to 10 mL/hr) continuously in order to keep the vein open. Feeding schedules vary, but one common regimen ramps up the nutrition over a few hours, levels off the rate for a few hours, and then ramps it down over a few more hours, in order to simulate a normal set of meal times.

Chronic TPN is performed through a central intravenous catheter, usually in the subclavian or jugular vein. Another common practice is to use a PICC line, which originates in the arm, and extends to one of the central veins, such as the subclavian. In infants, sometimes the umbilical vein is used.

Battery-powered ambulatory infusion pumps can be used with chronic TPN patients. Usually the pump and a small (100 ml) bag of nutrient (to keep the vein open) are carried in a small bag around the waist or on the shoulder. Outpatient TPN practices are still being refined.

Aside from their dependence on a pump, chronic TPN patients live quite normal lives.

Central IV lines flow through a catheter with its tip within a large vein, usually the superior vena cava or inferior vena cava, or within the right atrium of the heart.

There are several types of catheters that take a more direct route into central veins. These are collectively called *central venous lines*.

In the simplest type of central venous access, a catheter is inserted into a subclavian, internal jugular, or (less commonly) a femoral vein and advanced toward the heart until it reaches the superior vena cava or right atrium. Because all of these veins are larger than peripheral veins, central lines can deliver a higher volume of fluid and can have multiple lumens.

Another type of central line, called a Hickman line or Broviac catheter, is inserted into the target vein and then "tunneled" under the skin to emerge a short distance away. This reduces the risk of infection, since bacteria from the skin surface are not able to travel directly into the vein; these catheters are also made of materials that resist infection and clotting.

## Testing

The offered idea may be easily investigated in animals on Earth by using currently available devices. The experiment includes the following stages:

- 7) Using a hollow needle, the main blood system of a good healthy animal connects to a current heart-lung machine.
- 8) The animal is inserted under a transparent dome and air is gradually changed to a neutral gas (for example, nitrogen). If all signs are OK, we may proceed to the following stage some days later.

- 9) The animal is inserted under a transparent dome and air is slowly (tens of minutes) pumped out. If all signs are OK we may start the following stage.
- 10) Investigate how long time the animal can be in vacuum? How quick we can decompress and compress? How long the animal may live on artificial nutrition? And so on.
- 11) Design the lung (oxygenator) devices for people which will be small, light, cheap, reliable, safe, which delete gases from blood (especially those that will cause 'bends' in the case of rapid decompression, and work on decreasing the decompressing time).
- 12) Testing the new devices on animals then human volunteers.

### **Advantages of offered system.**

The offered method has large advantages in comparison with space suits:

- 9) The lung (oxygenator) devices are small, light, cheaper by tens to hundreds times than the current space suit.
- 10) It does not limit the activity of a working man.
- 11) The working time increases by some times. (less heat buildup, more supplies per a given carry weight, etc)
- 12) It may be widely used in the Earth for existing in poison atmospheres (industry, war), fire, rescue operation, under water, etc.
- 13) Method allows permanently testing (controlling) the blood and immediately to clean it from any poison and gases, wastes, and so on. That may save human lives in critical medical situations and in fact it may become standard emergency equipment.
- 14) For quick save the human life.
- 15) Pilots for high altitude flights.
- 16) The offered system is a perfect rescue system because you turn off from environment and exist INDEPENDENTLY from the environment. (Obviously excluding outside thermal effects, fires etc—but for example, many fire deaths are really smoke inhalation deaths; the bodies are often not burned to any extent. In any case it is much easier to shield searing air from the lungs if you are not breathing it in!)

### **Conclusion.**

The author proposes and investigates his old idea – a living human in space without the encumbrance of a complex space suit. Only in this condition can biological humanity seriously attempt to colonize space because all planets of Solar system (except the Earth) do not have suitable atmospheres. Aside from the issue of temperature, a suitable partial pressure of oxygen is lacking. In this case the main problem is how to satiate human blood with oxygen and delete carbonic acid gas (carbon dioxide). The proposed system would enable a person to function in outer space without a space suit and, for a long time, without food. That is useful also in the Earth for sustaining working men in an otherwise deadly atmosphere laden with lethal particulates (in case of nuclear, chemical or biological war), in underground confined spaces without fresh air, under water or a top high mountains above a height that can sustain respiration. There also could be numerous productive medical uses.

## **3. Electrostatic Levitation on Planet and Artificial Gravity for Space Ships and Asteroids\***

The author offers and researches the conditions which allow people and vehicles to levitate on the Earth using the electrostatic repulsive force. He shows that by using small electrically charged balls,



people and cars can take flight in the atmosphere. Also, a levitated train can attain high speeds. He has computed some projects and discusses the problems which can appear in the practical development of this method. It is also shown how this method may be used for creating artificial gravity (attraction force) into and out of space ships, space hotels, asteroids, and small planets which have little gravity.

-----  
 \*Presented as paper AIAA-2005-4465 at 41 Propulsion Conference, 10–13 July 2005, Tucson, Arizona, USA.  
 See also [1] Ch.15.

## **Introduction**

People have dreamed about a flying freely in the air without any apparatus for many centuries. In ancient books we can find pictures of flying angels or God sitting on clouds or in heaven. At the present time you can see the same pictures on walls in many churches.

Physicist is know only two methods for creating repulsive force: magnetism and electrostatics. Magnetism is well studied and the use of superconductive magnets for levitating a train has been widely discussed in scientific journals, but repulsive magnets have only a short-range force. They work well for ground trains but are bad for air flight. Electrostatic flight needs powerful electric fields and powerful electric charges. The Earth's electric field is very weak and cannot be used for levitation. The main innovations presented in this chapter are methods for creating powerful static electrical fields in the atmosphere and powerful, stable electrical charges of small size which allow levitation (flight) of people, cars, and vehicles in the air. The author also shows how this method can be utilized into and out of a space ship (space hotel) or on an asteroid surface for creating artificial gravity. The author believes this method has applications in many fields of technology.

Magnetic levitation has been widely discussed in the literature for a long time. However, there are few scientific works related to electrostatic levitation. Electrostatic charges have a high voltage and can create corona discharges, breakthrough and relaxation. The Earth's electrostatic field is very weak and useless for flight. That is why many innovators think that electrostatic forces cannot be useful for levitation.

The author's first innovations in this field which changed this situation were offered in (1982)<sup>1</sup>, and some practical applications were given in (1983)[1] Ch.15<sup>2</sup>. The idea was published in 1990 [1] Ch.15<sup>3</sup>,p. 79<sup>3</sup>. In the following presented work, these ideas and innovations are researched in more detail. Some projects are also presented to allow estimation of the parameters of the offered flight systems.

### **Brief description of innovation**

It is known that like electric charges repel, and unlike electric charges attract (Fig. 1a,b,c). A large electric charge (for example, positive) located at altitude induces the opposite (negative) electric charge at the Earth's surface (Figs. 1d,e,f,g) because the Earth is an electrical conductor. Between the upper and lower charges there is an electric field. If a small negative electric charge is placed in this electric field, this charge will be repelled from the like charges (on the Earth's surface) and attracted to the upper charge (Fig. 1d). That is the electrostatic lift force. The majority of the lift force is determined by the Earth's charges because the small charges are conventionally located near the Earth's surface. As shown below, these small charges can be connected to a man or a car and have enough force to lift and supports them in the air.

The upper charge may be located on a column as shown in Fig. 1d,e,f,g or a tethered air balloon (if we want to create levitation in a small town) (Fig. 1e), or air tube (if we want to build a big highway), or a tube suspended on columns (Fig.3-1f,g). In particular, the charges may be at two identically charged plates, used for a non-contact train (Fig.3- 3a).

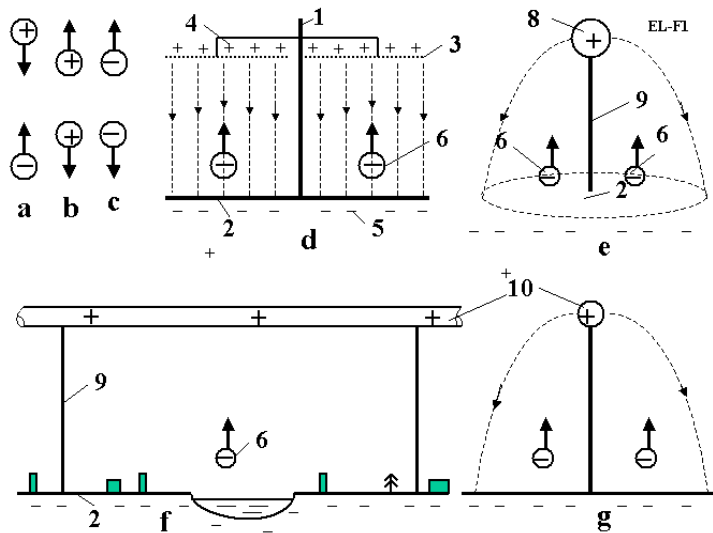


Fig. 3-1. Explanation of electrostatic levitation: a) Attraction of unlike charges; b,c) repulsion of like charges; d) Creation of the homogeneous electric field (highway); e) Electrical field from a large spherical charge ; f,g) Electrical field from a tube (highway) (side and front views). Notations are: 1, 9 – column, 2 – Earth (or other) surface charged by induction, 3 – net, 4 – upper charges, 5 – lower charges, 6 – levitation apparatus, 8 – charged air balloon, 9 – column, 10 – charged tube.

A lifting charge may use charged balls. If a thin film ball with maximum electrical intensity of below  $3 \times 10^6$  V/m is used, the ball will have a radius of about 1 m (the man mass is 100 kg). For a 1 ton car, the ball will have a radius of about 3 m (see the computation below and Fig. 3-2g,h,i). If a higher electric intensity is used, the balls can be small and located underneath clothes (see below and Fig. 3-2 a,b,c).

The offered method has big advantages in comparison to conventional vehicles (Figs.3-1 and 3-2):

- 1) No very expensive highways are necessary. Rivers, lakes, forests, and buildings are not obstacles for this method.
- 2) In given regions (Figs. 3-1 and 3-2) people (and cars) can move at high speeds (man up 70 km/hour and cars up to 200–400 km/hour) in any direction using simple equipment (small balls under their clothing and small engines (Fig. 3- 2a,b,c)). They can perform vertical takeoffs and landings.
- 3) People can reduce their weight and move at high speed, jump a long distance, and lift heavy weights.
- 4) Building high altitude homes will be easier.

This method can be also used for a levitated train and artificial gravity in space ships, hotels, and asteroids (Fig. 3-3a,b)

A space ship (hotel) definitely needs artificial gravity. Any slight carelessness in space can result in the cosmonaut, instruments or devices drifting away from the space ship. Presently, they are connected to the space ship by cables, but this is not comfortable for working. Science knows only two methods of producing artificial gravity and attractive forces: rotation of space ship and magnetism. Both methods are bad. The rotation creates artificial gravity only inside the space ship (hotel). Observation of space from a rotating ship is very difficult. The magnetic force is only effective over a very short distance. The magnets stick together and a person has to expend a large effort to move (it is the same as when you are moving on a floor smeared with glue).



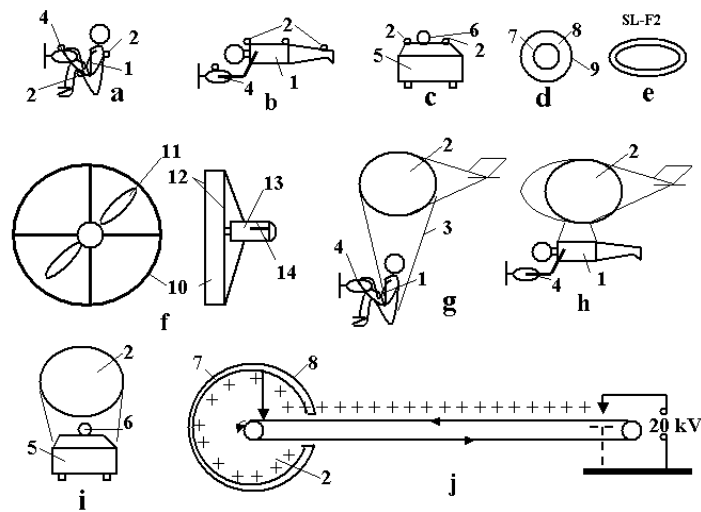


Fig. 3-2. Levitation apparatus: a,b) Single levitated man (mass up to 100 kg) using small highly charged balls 2. a) Sitting position; b) Reclining position; c) Small charged ball for levitating car; d) Small highly charged ball; e) Small highly charged cylindrical belt; f) Small air engine (forward and side views); g) Single levitated man (mass up to 100 kg) using a big non-highly charged ball which doesn't have an ionized zone (sitting position); h) The some man in a reclining position; i) Large charged ball to levitate a car which doesn't have an ionized zone; j) Installation for charging a ball using a Van de Graaff electrostatic generator (double generator potentially reaches 12 MV) in horizontal position. Notations: 1 – man; 2 – charged lifting ball; 4 – handheld air engine; 5 – car; 6 – engine (turbo-rocket or other); 7 – conducting layer; 8 – insulator (dielectric); 9 – strong cover from artificial fibers or whiskers; 10 – lagging; 11 – air propeller; 12 – preventive nets; 13 – engine; 14 – control knobs.

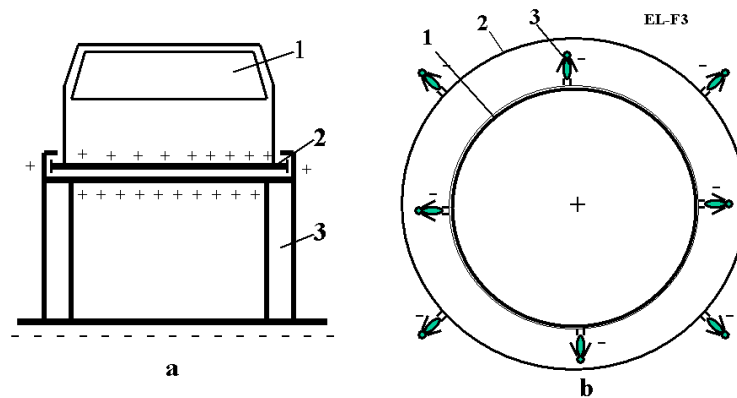


Fig. 3-3. Levitated train on Earth and artificial gravity into and on space ships and asteroids. a) Levitated train; b) Artificial gravity on a space ship. Notation: a) 1 – train; 2 – charged plates; 3 – insulated column; b) 1 – charged space body; 2 – space ship; 3 – man.

If then is a charge inside the space ship and small unlike charges attached to object elsewhere, then will fall back to the ship if they are dropped.

The same situation occurs for cosmonauts on asteroids or small planets which have very little gravity. If you charge the asteroid and cosmonauts with unlike electric charges, the cosmonauts will return to the asteroid during any walking and jumping.

The author acknowledges that this method has problems. For example, we need a high electrical intensity if we want to use small charged balls. This problem (and others) is discussed below.

## Projects

Let us estimate the main parameters for some offered applications. Most people understand the magnitudes and properties of applications better than theoretical reasoning and equations. The suggested application parameters are not optimal, but our purpose is to show the method can be utilized by current technology.

### 1. Levitation Highway (Fig.1d).

The height of the top net is 20 m. The electrical intensity is  $E_o = 2.5 \times 10^6 \text{ V} < E_c = (3-4) \times 10^6 \text{ V}$ . The voltage between the top net and the ground is  $U = 50 \times 10^6 \text{ V}$ . The width of each side of the road is 20 m. We first find the size of the lifting ball for the man (100 kg), car (1000 kg), or track (10,000 kg). Here  $R_c$  is the radius of the ionized zone [m]:

1) Flying man (mass  $M = 100 \text{ kg}$ ,  $\varepsilon = 3$ ,  $E_i = 200 \times 10^6 \text{ V/m}$ ,  $g \approx 10 \text{ m/s}^2$ )

$$E_a \leq \varepsilon E_i = 3 \times 200 \times 10^6, \quad a = \sqrt{\frac{kMg}{E_o E_a}} = \sqrt{\frac{9 \times 10^9 \times 100 \times 10}{2.5 \times 10^6 \times 6 \times 10^8}} \approx 0.08 \text{ m}, \quad R_c = \sqrt{\frac{E_a}{E_c}} \approx 1 \text{ m}.$$

Notice that the radius of a single ball supporting the man is only 8 cm, or the man can use two balls  $a = 5-6 \text{ cm}$ ,  $R_c = 0.75 \text{ m}$  (or even more smaller balls). If the man uses a 1 m cylindrical belt, the radius of the belt cross-section area is 1.1 cm,  $\sigma = 100 \text{ kg/mm}^2$ ,  $E_a = 600 \times 10^6 \text{ V/m}$  ([1] Figs. 15.10 and 15.11). The belt may be more comfortable for some people.

2) With the same calculation you can find that a car of mass  $M = 1000 \text{ kg}$  will be levitated using a single charged ball  $a = 23 \text{ cm}$ ,  $R_c = 3.2 \text{ m}$  (or two balls with  $a = 16 \text{ cm}$ ,  $R_c = 2.3 \text{ m}$ ).

3) A truck of mass  $M = 10,000 \text{ kg}$  will be levitated using a single charged ball  $a = 70 \text{ cm}$ ,  $R_c = 10 \text{ m}$  (or two balls with  $a = 0.5 \text{ m}$ ,  $R_c = 7 \text{ m}$ ).

### 2. Levitating tube highway

Assume the levitation highway has the design of Fig. 1f,g where the top net is changed to a tube.

Take the data  $E_o = 2.5 \times 10^6 \text{ V} < E_c = (3-4) \times 10^6 \text{ V}$ ,  $E_a = 2 \times 10^8 \text{ V/m}$ ,  $h = 20 \text{ m}$ . This means the electrical intensity,  $E_o$ , at ground level is the same as in the previous case. The required radius,  $a$ , of the top tube is

$$\frac{a}{h} = \frac{E_o}{2E_a} = 0.00625, \quad a = 0.00625h = 0.125 \text{ m}, \quad R_c = a \frac{E_a}{E_o} = 10 \text{ m}.$$

The diameter of the top tube is 0.25 m, the top ionized zone has a radius of 10 m.

### 3. Charged ball located on a high mast or tower

Assume there is a mast (tower) 500 m high with a ball of radius  $a = 32 \text{ m}$  at its top charged up to  $E_a = 3 \times 10^8 \text{ V/m}$ . The charge is

$$q = \frac{a^2 E_a}{k} = 34 \text{ C}, \quad E_o = k \frac{2q}{h^2} = 2.45 \times 10^6 \text{ V/m}.$$

This electrical intensity at ground level means that within a radius of approximately 1 km, people, cars and other loads can levitate.

### 4. Levitation in low cumulonimbus and thunderstorm clouds

In these clouds the electrical intensity at ground level is about  $E_o = 3 \times 10^5 - 10^6 \text{ V/m}$ . A person can take more (or more highly charged) balls and levitate.

### 5. Artificial gravity on space ship's or asteroids

Assume the space ship is a sphere with an inner radius at  $a = 10 \text{ m}$  and external radius of 13 m. We can create the electrical intensity  $E_o = 2.5 \times 10^6 \text{ V/m}$  without an ionized zone. The electrical charge is  $q = a^2 E_o / k = 2.8 \times 10^{-2} \text{ C}$ . For a man weighing 100 kg ( $g = 10 \text{ m/s}^2$ , force  $F = 1000 \text{ N}$ ), it is sufficient to

have a charge of  $q = F/E_0 = 4 \times 10^{-4}$  C and small ball with  $a = 0.1$  m and  $E_a = qk/a^2 = 3.6 \times 10^8$  V/m. In outer space at the ship's surface, the artificial gravity will be  $(10/13)^2 = 0.6 = 60\%^{10}$  of  $g$ .

## 6. Charged ball as an accumulator of energy and rocket engine

The computations show the relative  $W/M$  energy calculated from safe tensile stress does not depend on  $E_a$ . A ball cover with a tensile stress of  $\sigma = 200$  kg/mm<sup>2</sup> reaches 2.2 MJ/kg. This is close to the energy of conventional powder (3 MJ/kg). If whiskers or nanotubes are used the relative electrical storage energy will be close to than of liquid rocket fuel.

Two like charged balls repel one another and can give significant acceleration for a space vehicle, VTOL aircraft, or weapon.

## Discussion

Electrostatic levitation could create a revolution in transportation, building, entertainment, aviation, space flights, and the energy industry.

The offered method needs development and testing. The experimental procedure it is not expensive. We just need a ball with a thin internal conducting layer, a dielectric cover, and high voltage charging equipment. This experiment can be carried out in any high voltage electric laboratory. The proposed levitation theory is based on proven electrostatic theory. There may be problems may be with discharging, blockage of the charge by the ionized zone, breakdown, and half-life of the discharge, but careful choice of suitable electrical materials and electric intensity may be also to solve them. Most of these problems do not occur in a vacuum.

Another problem is the affects of the strong electrostatic field on a living organism. Only experiments using animals can solve this. In any case, there are protection methods – conducting clothes or vehicle is (from metal or conducting paint) which offer a defense against the electric field.

## 4. A NEW METHOD OF ATMOSPHERIC REENTRY FOR SPACE SHIPS\*

In recent years, industry has produced high-temperature fiber and whiskers. The author examined the atmospheric reentry of the USA Space Shuttles and proposed the use of high temperature tolerant parachute for atmospheric air braking. Though it is not large, a light parachute decreases Shuttle speed from 8 km/s to 1 km/s and Shuttle heat flow by 3 - 4 times. The parachute surface is opened with backside so that it can emit the heat radiation efficiently to Earth-atmosphere. The temperature of parachute is about 1000-1300° C. The carbon fiber is able to keep its functionality up to a temperature of 1500-2000° C. There is no conceivable problem to manufacture the parachute from carbon fiber. The proposed new method of braking may be applied to the old Space Shuttles as well as to newer spacecraft designs.

## Introduction

In 1969 author applied a new method of global optimization to the problem of atmospheric reentry of spaceships ([2] Ch.8, Ref. [1] p. 188). The general analysis presented an additional method to the well-known method of outer space to Earth-atmosphere reentry ("high-speed corridor"). There is a low-speed corridor when the total heat is less than in a conventional high-speed passage. In that time for significantly decreasing the speed of a spaceship retro- and landing rocket engine needed to be used. That requires a lot of fuel. It is not acceptable for modern spaceships. Nowadays the textile industry produces heat resistant fiber that can be used for a new parachute system to be used in a high-temperature environment ([2] Ch.8, Ref.[2]-[4]).

---

\* Presented as Bolonkin's paper AIAA-2006-6985 to Multidisciplinary Analysis and Optimization Conference, 6-8 Sept. 2006, Portsmouth, Virginia. USA See also [2] Ch. 8.

The control is following: if  $d\theta/dt > 0$  the all lift force  $L = L_P = 0$ . When the Shuttle reaches the low speed the parachute area can be decreased or parachute can be detached. That case not computed. Used control is not optimal.

The results of integration are presented below. Used data: parachute area are  $S_P = 1000, 2000, 4000$   $m^2$  ( $R_P = 17.8, 25.2, 35.7$  m);  $m = 104,000$  kg. The dash line is data of the Space Shuttle without a parachute.

### Conclusion

The widespread production of high temperature fibers and whiskers allows us to design high-temperature tolerant parachutes, which may be used by space apparatus of all types for braking in a rarified planet atmosphere. The parachute has open backside surface that rapidly emits the heat radiation to outer space thereby quickly decreasing the parachute temperature. The proposed new method significantly decreases the maximum temperature and heat flow to main space apparatus. That decreases the heat protection mass and increases the useful load of the spacecraft. The method may be also used during an emergency reentering when spaceship heat protection is damaged (as in horrific instance of the Space Shuttle "Columbia").



Figure 4-1. Space Shuttle "Atlantic". during reentry.

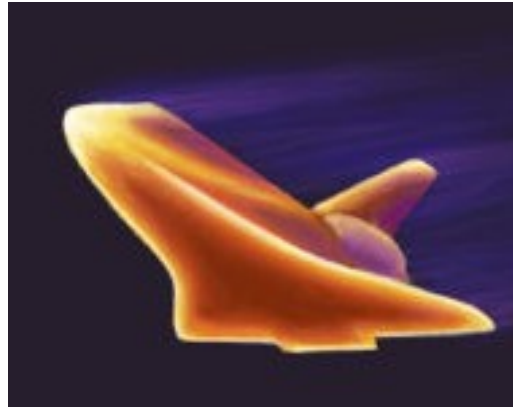


Figure 4-2. The outside of the Shuttle heats to over 1,550 °C



Figure 4-3. Endeavour deploys drag chute after touch-down.

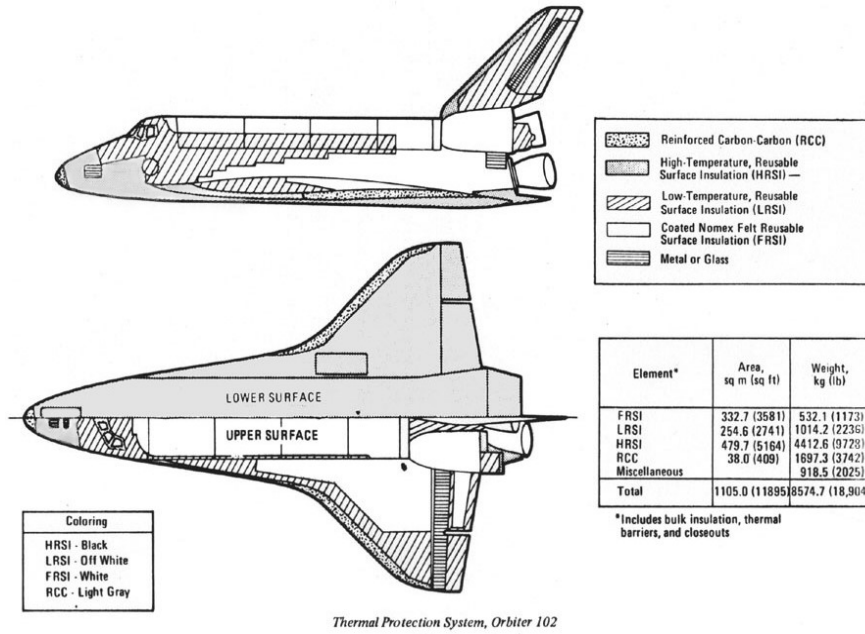


Figure 4-4. Space Shuttle Thermal Protection System Constituent Materials

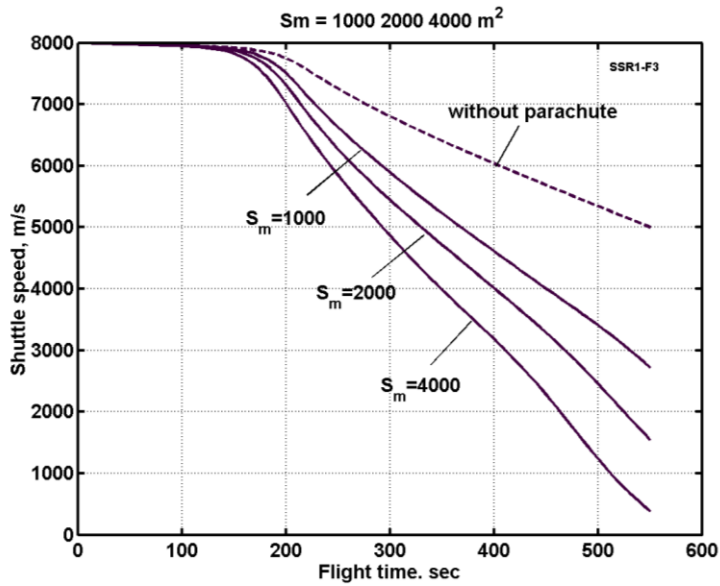


Figure 4-5. Decreasing of Space Shuttle speed with parachute and without it.  $S_m = S_p$ .

## 5. Inflatable Dome for Moon, Mars, Asteroids and Satellites\*

On a planet without atmosphere, sustaining human life is very difficult and dangerous, especially during short sunlit period when low temperature prevails. To counter these

\* Presented as paper AIAA-2007-6262 to AIAA Conference "Space-2007", 18-20 September 2007, Long Beach, CA, USA. Published in <http://arxiv.org>. See also [3] Ch.2.

environmental stresses, the author offer an innovative artificial "Evergreen" dome, an inflated hemisphere with interiors continuously providing a climate like that of Florida, Italy and Spain. The "Evergreen" dome theory is developed, substantiated by computations that show it is possible for current technology to construct and heat large enclosed volumes inexpensively. Specifically, a satisfactory result is reached by using high altitude magnetically supported sunlight reflectors and a special double thin film as an enclosing skin, which concentrates solar energy inside the dome while, at the same time, markedly decreasing the heat loss to exterior space. Offered design may be employed for settlements on the Moon, Mars, asteroids and satellites.

### ***Introduction***

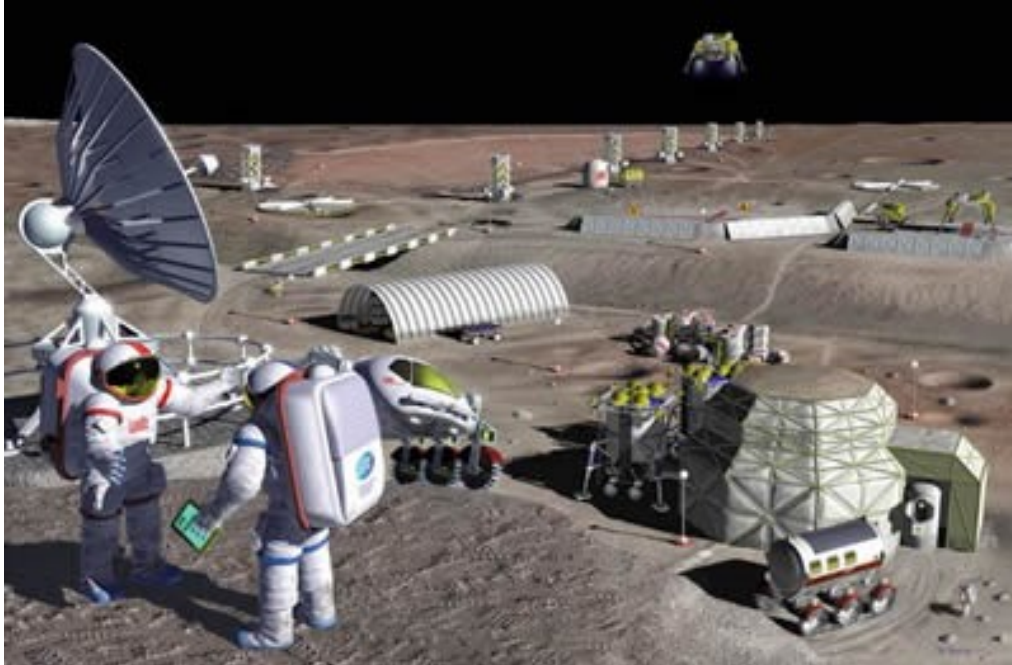
The real development of outer space (permanent human life in space) requires two conditions: all-sufficient space settlement and artificial life conditions close to those prevailing currently on the Earth. (Such a goal extends what is already being attempted in the Earth-biosphere—for example at the 1<sup>st</sup> Advanced Architecture Contest, “Self-Sufficient Housing”, sponsored by the Institute for Advanced Architecture of Catalonia, Spain, during 2006.) The first condition demands production of all main components needed for human life: food, oxidizer, and energy within the outer space and Solar System body colony.

The second requisite condition is a large surface settlement having useful plants, attractive flowers, splashing water pools, walking and sport areas, etc. All these conditions may be realized within large 'greenhouses' [1] that will produce food, oxidizer and “the good life” conditions. Human life in outer space and on other planetary or planet-like places will be more comfortable if it uses A.A. Bolonkin’s macro-project proposal - staying in outer space without special spacesuit [2], p. 335 (mass of current spacesuit reaches 180 kg). The idea of this paper may be used also for control of Earth's regional and global weather and for converting our Earth’s desert and cold polar zone regions into edenic subtropical gardens ( [3] Ch.2, Ref.[3]-[4]).

The current conditions in Moon, Mars and Space are far from comfortable. For example, the Moon does not have any useful atmosphere, the day and night continues for 14 Earth days each, there are deadly space radiation and meteor bombardments, etc.

Especially during wintertime, Mars could provide only a meager and uncomfortable life-style for humans, offering low temperatures, strong winds. The distance north or south from that planet’s equator is amongst the most significant measured environmental variables underlying the physical differences of the planet. In other words, future humans living in the Moon and Mars must be more comfortable for humans to explore and properly exploit these distant and dangerous places.

Possibly the first true architectural attempt at constructing effective artificial life-support systems on the climatically harsh Moon will be the building of greenhouses. Greenhouses are maintained nearly automatically by heating, cooling, irrigation, nutrition and plant disease management equipment. Humans share commonalities in their responses to natural environmental stresses that are stimulated by night cold, day heat, absent atmosphere, so on. Darkness everywhere inflicts the same personal visual discomfort and disorientation as cosmonauts/astronauts experience during their space-walks—that of being adrift in featureless space! With special clothing and shelters, humans can adapt successfully to the well-landmarked planet Mars, for example. Incontrovertibly, living on the Moon, beneath Mars’ low-density atmosphere is difficult, even when tempered by strong conventional protective buildings.



Moon base.

### ***'Evergreen' Inflated Domes***

Our macro-engineering concept of inexpensive-to-construct-and-operate “Evergreen” inflated surface domes is supported by computations, making our macro-project speculation more than a daydream. Innovations are needed, and wanted, to realize such structures upon the Moon of our unique but continuously changing life.

### ***Description and Innovations***

#### **Dome.**

Our basic design for the Moon-Mars people-housing “Evergreen” dome is presented in Figure 5-1, which includes the thin inflated double film dome. The innovations are listed here: (1) the construction is air-inflatable; (2) each dome is fabricated with very thin, transparent film (thickness is 0.2 to 0.4 mm) without rigid supports; (3) the enclosing film is a two-layered structural element with air between the layers to provide insulation; (4) the construction form is that of a hemisphere, or in the instance of a roadway/railway a half-tube, and part of the film has control transparency and a thin aluminum layer about 1  $\mu$  or less that functions as the gigantic collector of incident solar radiation (heat). Surplus heat collected may be used to generate electricity or furnish mechanical energy; and (5) the dome is equipped with sunlight controlling louvers [also known as, “jalousie”, a blind or shutter having adjustable slats to regulate the passage of air and sunlight] with one side thinly coated with reflective polished aluminum of about 1  $\mu$  thickness. Real-time control of the sunlight’s entrance into the dome and nighttime heat’s exit is governed by the shingle-like louvers or a controlled transparency of the dome film.

Variant 1 of artificial inflatable Dome for Moon and Mars is shown in Figure 5-1. Dome has top thin double film 4 covered given area and single under ground layer 6. The space between layers 4 - 6 is about 3 meters and it is filled by air. The support cables 5 connect the top and underground layers and Dome looks as a big air-inflated beach sunbathing or swimming mattress. The Dome includes hermetic sections connected by corridors 2 and hermetic lock chambers 3. Topmost film controls the dome’s



transparency (and reflectivity). That allows people to closely control temperature affecting those inside the dome. Topmost film also is of a double-thickness. When a meteorite pushes hole in the topmost double film, the lowermost layer closes the hole and puts temporary obstacles in the way of the escaping air. Dome has a fruitful soil layer, irrigation system, and cooling system 9 for supporting a selected given humidity. That is, a closed-biosphere with a closed life-cycle that regularly produces an oxidizer as well as sufficient food for people and their pets, even including some species of farm animals. Simultaneously, it is the beautiful and restful Earth-like place of abode. The offered design has a minimum specific mass, about  $7\text{-}12\text{ kg/m}^2$  (air - 3 kg, film - 1 kg, soil - 3 - 8 kg). Mass of an example area of  $10\times 10\text{ m}$  is about 1 metric ton (oftentimes spelt “tonnes”).

Figure 2 illustrates the second thin transparent dome cover we envision. The Dome has double film: semispherical layer (low pressure about 0.01 - 0.1 atmosphere, atm.) and lower layer (high 1 atm. pressure). The hemispherical inflated textile shell—technical “textiles” can be woven (weaving is an interlacement of warp and weft) or non-woven (homogenous films)—embodies the innovations listed: (1) the film is very thin, approximately 0.1 to 0.3 mm. A film this thin has never before been used in a major building; (2) the film has two strong nets, with a mesh of about  $0.1 \times 0.1\text{ m}$  and  $a = 1 \times 1\text{ m}$ , the threads are about 0.3 mm for a small mesh and about 1 mm for a big mesh.

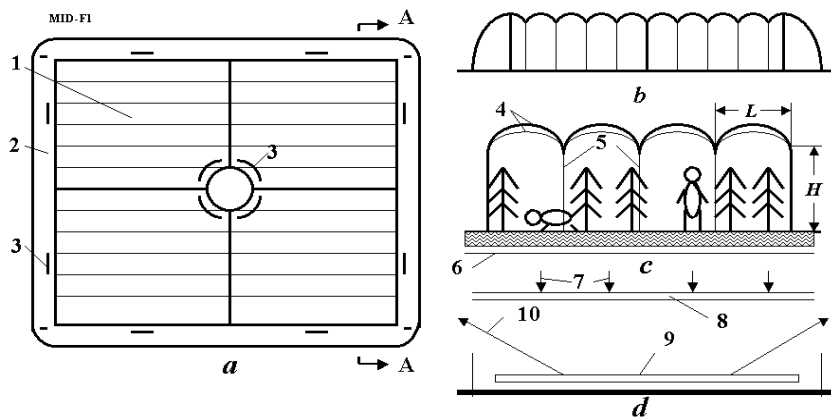


Figure 5-1. Variant 1 of artificial inflatable Dome for Moon and Mars. (a) top view of dome; (b) cross-section AA area of dome; (c) inside of the Dome; (d) Cooling system. Notations: 1 - internal section of Dome; 2 - passages; 3 - doors; 4 - transparency thin double film (“textiles”) with control transparency; 5 - support cables; 6 - lower underground film; 7 - solar light; 8 - protection film; 9 - cooling tubes; 10 - radiation of cooling tubes.

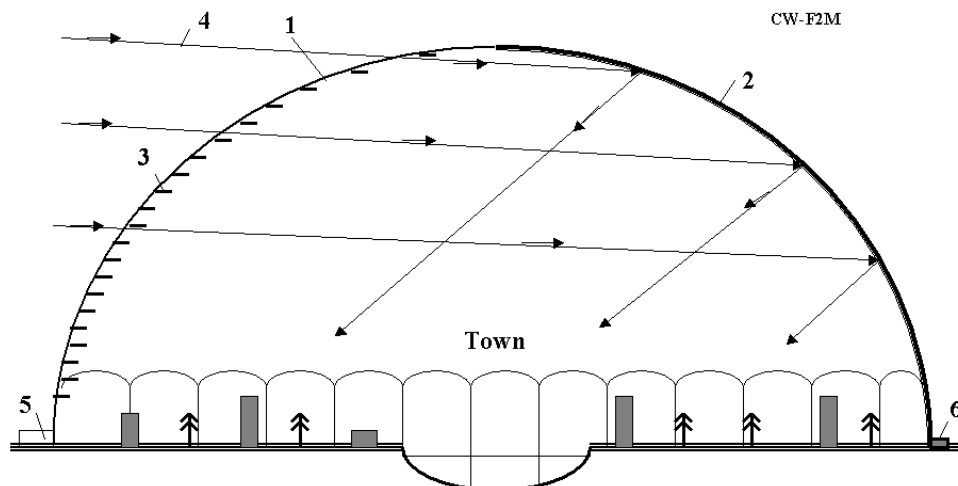


Figure 5-2. Variant 2 of artificial inflatable Dome for Moon and Mars. Notations: 1 - transparent thin double film ("textiles"); 2 - reflected cover of hemisphere; 3 - control louvers (jalousie); 4 - solar beams (light); 5 - enter (dock chamber); 6 - water extractor from air. The lower section has air pressure about 1 atm. The top section has air pressure of 0.01 - 0.1 atm.

The net prevents the watertight and airtight film covering from being damaged by micrometeorites; the film incorporates a tiny electrically-conductive wire net with a mesh of about  $0.001 \times 0.001$  m and a line width of about  $100 \mu$  and a thickness near  $1 \mu$ . The wire net can inform the "Evergreen" dome supervisors (human or automated equipment) concerning the place and size of film damage (tears, rips, punctures, gashes); the film is twin-layered with the gap —  $c = 1$  m and  $b = 2$  m—between the layer covering. This multi-layered covering is the main means for heat insulation and anti-puncture safety of a single layer because piercing won't cause a loss of shape since the film's second layer is unaffected by holing; the airspace in the dome's twin-layer covering can be partitioned, either hermetically or not; and part of the covering may have a very thin shiny aluminum coating that is about  $1 \mu$  for reflection of non-useful or undesirable impinging solar radiation.

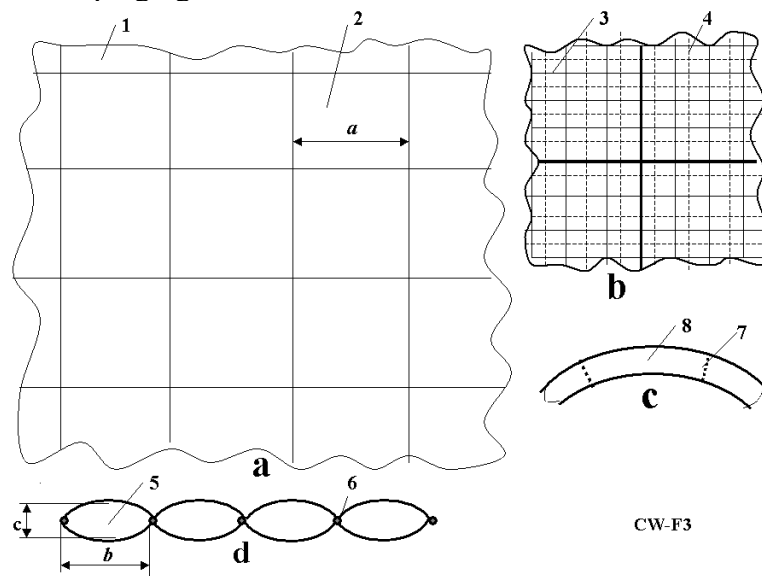


Figure 5-3. Design of "Evergreen" cover. Notations: (a) Big fragment of cover; (b) Small fragment of cover; (c) Cross-section of cover; (d) Longitudinal cross-section of cover; 1 - cover; 2 - mesh; 3 - small mesh; 4 - thin electric net; 5 - sell of cover; 6 - tubes; 7 - film partition (non hermetic); 8 - perpendicular cross-section area.

Offered inflatable Dome can cover a big region (town) and create beautiful Earth-like conditions on an outer space solid body (Figure 5-4a). In future, the "Evergreen" dome can cover a full planetary surface (Moon, Mars, asteroid) (Figure 5-4b). Same type of domes can cover the Earth's lands, converting them (desert, cool regions) into beautiful gardens with **controlled weather and closed** material life cycles.

### Location, Illumination and Defending Human Settlements from Solar Wind and Space Radiation

The Moon makes one revolution in about 29 Earth days. If we want to have conventional Earth artificial day and natural solar lighting, the settlement must locate near one or both of the Moon's poles and have a magnetic control mirror suspended at high altitude in given (stationary) place (Figure 5-5). For building this mirror (reflector) may use idea and theory of magnetic levitation developed by A.A. Bolonkin in [3] Ch.2, Ref.[5]. If reflector is made with variable focus, as in [3] p. 306, Figure 16.3, then it may well be employed as a concentrator of sunlight and be harnessed for energy during "night" (Earth-time).

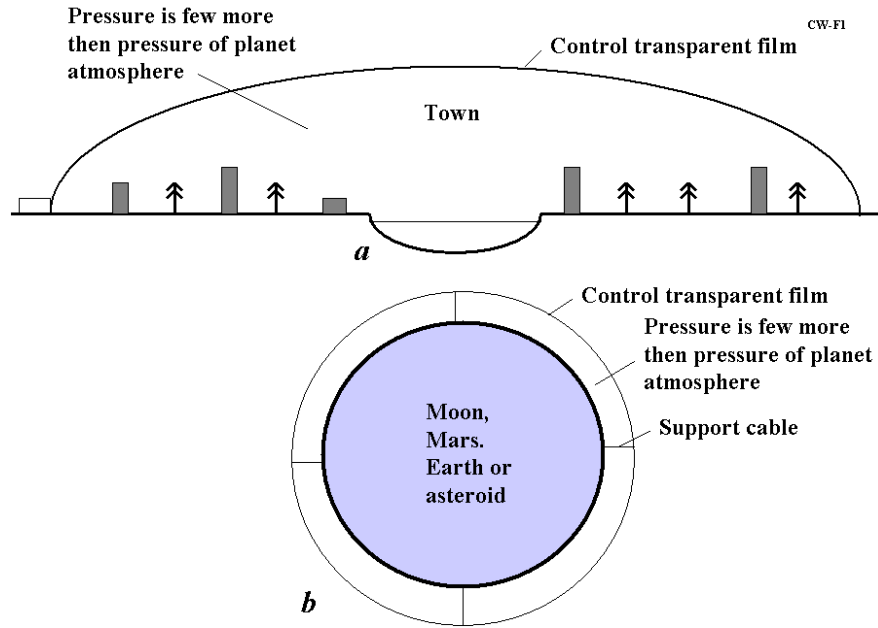


Figure 5-4. (a) Inflatible film dome over a single town; (b) Inflatible film dome covering a planet (Moon, Mars) and asteroid. Same type of domes can cover the Earth's extreme climate regions and convert them (desert, cool regions) into beautiful gardens with controlled weather and closed life cycles.

The second important feature of the offered installation is defense of the settlement from solar wind and all cosmic radiation. It is known that the Earth's magnetic field is a natural defense for living animals, plants and humans against high-energy particles, such as protons, of the solar wind. The artificial magnetic field near Moon settlement is hundreds of times stronger than the Earth's magnetic field. It will help to defend delicate humans. The polar location of the planned settlement also decreases the intensity of the solar wind. Location of human settlement in polar zone(s) Moon craters also decreases the solar wind radiation. People can move to an underground cosmic radiation protective shelter, a dugout or bunker, during periods of high Sun activity (solar flashes, coronal mass ejections).

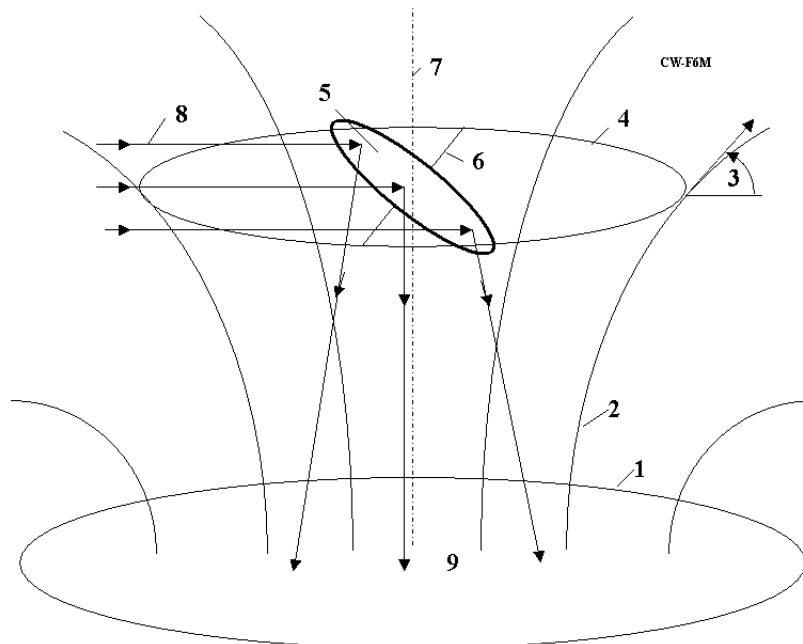


Figure 5-5. Magnetic control mirror is suspended at high altitude over human Moon settlement. Notations: 1 -superconductivity ground ring; 2 - magnetic lines of ground superconductivity ring; 3 -angle ( $\alpha$ ) between magnetic line of the superconductivity ground ring and horizontal plate (see Eq. (6)); top superconductivity ring for supporting the mirror (reflector) 5; 6 - axis of control reflector (which allows turning of mirror); 7 - vertical axis of the top superconductivity ring; 8 - solar light; 9 – human settlement.

The theory and computation of this installation is in theoretical section, below. The mass of the full reflector (rings, mirror, head screens is about 70 - 80 kg; if the reflector is used also as powerful energy source, then the mass can reach 100 - 120 kg. Note: for lifting, the reflector does not need a rocket. The magnetic force increases near ground (see Eq. (3)). This force lifts the reflector to the altitude that is required by its usage. The reflector also will be structurally stable because it is located in magnetic hole of a more powerful ground ring magnet.

The artificial magnetic field may be used, too, for free flying of men and vehicles, as it is described in [4]-[5]. If a planet does not have enough gravity, then electrostatic artificial gravity may be used [3], Ch. 15.

The magnetic force lifts the reflector to needed altitude.

Figure 6 illustrates a light-weight, possibly portable house, using the same basic construction materials as the dwelling/workplace.

### *Inflatable Space Hotel*

We live during the 21<sup>st</sup> Century when Earthly polar tourism is just becoming a scheduled pastime and the world public anticipates outer space tourism. The offered inflatable outer space (satellite) hotel for tourists is shown in Figure 7. That has the common walking area (garden) covered by a film having the controlled transparency (reflectivity), internal sections (living rooms, offices, restaurants, concert hall, storage areas, etc.). Hotel has electrostatic artificial gravity [3], and magnetic field. The electrostatic artificial gravity creates usual Earth environment, the magnetic field allows people to easily fly near the outer space hotel and still be effectively defended from the dangerous, and sometimes even lethal, solar wind.

Hotel has electrostatic artificial gravity and magnetic field that will permit people to freely fly safely near the hotel even when radiation in outer space is closely present and intense.

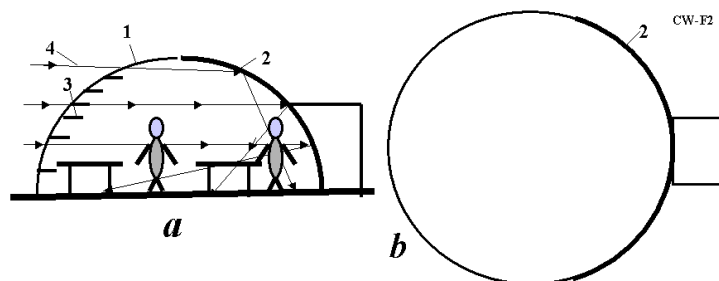


Figure 5-6. Inflatable film house for planet. Notation: (a) Cross-section area; (b) Top view. The other notations are same with Figure 5-2.

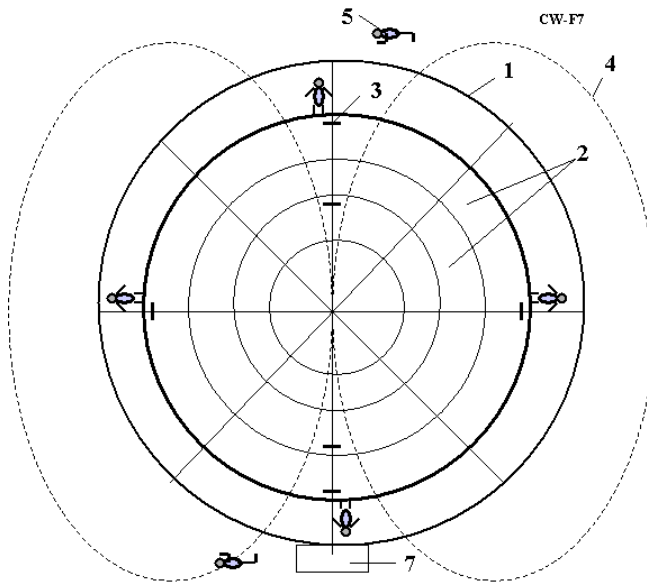


Figure 5-7. Inflatable space (satellite) hotel. Notations: 1 - inflatable hotel (control transparency cover film); 2 - internal sections of hotel (living rooms, offices, café, music hall, storage, etc.); 3 - door and windows in internal sections; 4 - magnetic line; 5 - outer space flying person (within hotel's magnetic field, [5]); 6 - common walking area (garden). 7 - docking chamber.

### ***Visit Outer Space without a Spacesuit.***

Current spacesuit designs are very complex and expensive “machines for living”. They must, at minimum, unfailingly support human life for some period of time. However, the spacesuit makes a cosmonaut/astronaut barely mobile, slow moving, prevents exertive hard work, creates bodily discomfort such as pain or irritations, disallows meals in outer space, has no toilet, etc. Mass of current spacesuits is about 180 kg. Cosmonauts/Astronauts—these should be combined into “Spationauts” as the 20<sup>th</sup> Century descriptions were derived from Cold War superpower competition—must have spaceship or special outer space home habitat located not far from where they can undress for eating, toilet, and sleep as well as rest.

Why do humans need the special spacesuit in outer space, or on atmosphere-less bodies of the Solar System? There is only one reason – we need an oxygen atmosphere for breathing, respiration. Human evolution in the Earth-biosphere has created lungs that aerate our blood with oxygen and delete the carbonic acid. However, in a particularly harsh environment, we can do it more easily by artificial apparatus. For example, surgeons when they perform surgery on heart or lungs connect the patient to the apparatus “Heart-lung machine”, temporarily stopping the patient’s respiration and hear-beat. In [3] at p. 335, it is suggested that a method exists by donating some human blood, with the use of painless suture needles, is possible and that the blood can then be passed through artificial "lungs", just as is done in hospitals today.

We can design a small device that will aerate people’s blood with oxygen infusion and delete the carbonic acid. To make offshoots from main lungs arteries to this device, we would turn on/off the artificial breathing at anytime and to be in vacuum (asteroid or planet without atmosphere) or bad or poisonous atmosphere, underwater a long time. In outer space we can be in conventional spacesuit defending the wearer from harmful solar light. Some type of girdle-like total body wrapping is required to keep persons in outer space from expanding explosively.

This idea may be checked with animal experiments in the Earth. We use the current "Heart-Lung" medical apparatus and put an animal under bell glass and remove the air inside the bell jar.

We can add into the blood all appropriate nutrition and, thusly, be without normal eating food for a long period of time; it is widely known that many humans in comas have lived fairly comfortably for many years entirely with artificial nourishment provided by drip injection.

The life possible in outer space without spacesuit will be easier, comfortable and entirely safe.

### **Macro-Projects**

The dome shelter innovations outlined here can be practically applied to many cases and climatic regimes. We suggest initial macro-projects could be small (10 m diameter) houses (Figure 6) followed by an “Evergreen” dome covering a land area 200 m × 1000 m, with irrigated vegetation, homes, open-air swimming pools, playground, “under the stars style” concert hall.

The house and “Evergreen” dome have several innovations: magnetic suspended Sun reflector, double transparent insulating film, controllable жалюзи coated with reflective aluminum (or film with transparency control properties and/or structures) and an electronic cable mesh inherent to the film for dome safety/integrity monitoring purposes. By undertaking to construct a half-sphere house, we can acquire experience in such constructions and explore more complex constructions. By computation, a 10 m diameter home has a useful floor area of 78.5 m<sup>2</sup>, airy interior volume of 262 m<sup>3</sup> covered by an envelope with an exterior area of 157 m<sup>2</sup>. Its film enclosure material would have a thickness of 0.0003 m with a total mass of about 100 kg.

A city-enclosing “Evergreen” dome of 200 m × 1000 m (Figure 2, with spherical end caps) could have calculated characteristics: useful area =  $2.3 \times 10^5$  m<sup>2</sup>, useful volume  $17.8 \times 10^6$  m<sup>3</sup>, exterior dome area of  $3.75 \times 10^5$  m<sup>2</sup>, comprised of a film of 0.0003 m thickness and about 200 tonnes. If the “Evergreen” dome were formed with concrete 0.25 m thick, the mass of the city-size envelope would be  $200 \times 10^3$  tonnes, which is a thousand times heavier. Also, just for comparison, if we made a gigantic “Evergreen” dome with stiff glass, thousands of tonnes of steel, glass would be necessary and such materials would be very costly to transport hundreds or thousands of kilometers into outer space to the planet where they would be assembled by highly-paid but risk-taking construction workers. Our film is flexible and plastically deformable. It can be relatively cheap in terms of manufacturing cost. The single greatest boon to “Evergreen” dome construction, whether on the Moon, in Mars or elsewhere, is the protected cultivation of plants under a protective dome that efficiently captures energy from the available and technically harnessed sunlight.

### **Discussion**

As with any innovative macro-project proposal, the reader will naturally have many questions. We offer brief answers to the two most obvious questions our readers are likely to ponder.

#### *(1) Cover damage.*

The envelope contains a rip-stopping cable mesh so that the film cannot be damaged greatly. Its structured cross-section of double layering governs the escape of air inside the living realm.

Electronic signals alert supervising personnel of all ruptures and permit a speedy repair effort by well-trained responsive emergency personnel. The topmost cover has a strong double film.

#### *(2) What is the design-life of the dome film covering?*

Depending on the kinds of materials used, it may be as much a decade (up 30 years). In all or in part, the durable cover can be replaced periodically as a precautionary measure by its owners.

### **Conclusion**

Utilization of “Evergreen” domes can foster the fuller economic development of the Moon, Mars and Earth itself - thus, increasing the effective area of territory dominated by humans on, at least, three

celestial bodies. Normal human health can be maintained by ingestion of locally grown fresh vegetables and healthful “outdoor” exercise. “Evergreen” domes can also be used in the Earth’s Tropics and Temperate Zone. Eventually, “Evergreen” domes may find application on the Moon or Mars since a vertical variant, inflatable space towers [1], are soon to become available for launching spacecraft inexpensively into Earth orbit or on to long-duration interplanetary outer spaceflights.

## **6. AB METHOD OF IRRIGATION ON PLANET WITHOUT WATER (CLOSED-LOOP WATER CYCLE)\***

Author methodically researched a revolutionary Macro-engineering idea for a closed-loop freshwater irrigation and in this chapter it is unveiled in some useful detail. We offer to cover a given site by a thin, enclosure film (with controlled heat conductivity and clarity) located at an altitude of 50 – 300 m. The film is supported, at its working altitude, by small additional induced air over-pressuring, and anchored to the ground by thin cables. We show that this closed dome allows full control of the weather within at a given planetary surface region (the day is always fine, it will rain only at night, no strong winds). The average Earth (white cloudy) reflectance equals 0.3 - 0.5. Consequently, Earth does lose about 0.3 - 0.5 of the maximum potential incoming solar energy. The dome (having control of the clarity of film and heat conductivity) converts the cold regions to controlled subtropics, hot deserts and desolate wildernesses to prosperous regions blessed temperate climate. This is, today, a realistic and cheap method of evaporation-economical irrigation and virtual weather control on Earth!

### ***Description and Innovations***

Our idea is a closed dome covering a local region by a thin film with controlled heat conductivity and optionally-controlled clarity (reflectivity, albedo, carrying capacity of solar spectrum)(Fig.6-1). The film is located at an altitude of ~50 – 300 m. The film is supported at this altitude by a small additional air pressure produced by ventilators sitting on the ground. The film is connected to Earth's surface by tethering cables. The cover may require double-layer film. We can control the heat conductivity of the dome cover by pumping in air between two layers of the dome film cover and change the solar heating due to sunlight heating by control of the cover’s clarity. That allows selecting for different conditions (solar heating) in the covered area and by pumping air into dome. Envisioned is a cheap film having liquid crystal and conducting layers. The clarity is controlled by application of selected electric voltage. These layers, by selective control, can pass or blockade the available sunlight (or parts of solar spectrum) and pass or blockade the Earth’s radiation. The incoming and outgoing radiations have different wavelengths. That makes control of them separately feasible and, therefore, possible to manage the heating or cooling of the Earth’s surface under this film. In conventional conditions about 50% of the solar energy reaches the Earth surface. Much is reflected back to outer space by white clouds that shade approximately 65% of the Earth’s land/water surface. In our closed water system the rain (or at least condensation) will occur at night when the temperature is low. In open atmosphere, the Sun heats the ground; the ground must heat the whole troposphere (4 – 5 km) before stable temperature rises happen. In our case, the ground heats ONLY the air in the dome (as in a hotbed). We have, then, a literal greenhouse effect. That means that many cold regions (Alaska, Siberia, northern Canada) may absorb more solar energy and became a temperate climate or sub-tropic

---

\* Presented in electronic library of Cornell University <http://arxiv.org> in 27 December 2007. See also [3] Ch.1.



climate (under the dome, as far as plants are concerned). That also means the Sahara and other deserts can be a prosperous regions with a fine growing and living climate and with a closed-loop water cycle.

The building of a film dome is easy. We spread out the film over Earth's surface, turn on the pumping propellers and the film is raised by air over-pressure to the needed altitude limited by the support cables. Damage to the film is not a major trouble because the additional air pressure is very small (0.0001- 0.01 atm) and air leakage is compensated for by spinning propeller pumps. Unlike in an outer space colony or extra-Earth planetary colony, the outside air is friendly and, at worst, we might lose some heat (or cold) and water vapor.

*The first main innovation* of our dome, and its main difference from a conventional hotbed, or glasshouse, is the inflatable HIGH span of the closed cover (up to 50 – 300 m). The elevated height of the enclosed volume aids organizing of a CLOSED LOOP water cycle - accepting of water vaporized by plants and returning this water in the nighttime when the air temperature decreases. That allows us to perform irrigation in the vast area of Earth's land that does not have enough freshwater for agriculture. We can convert the desert and desolate wildernesses into Eden-like gardens without expensive delivery of remotely obtained and transported freshwater. The initial amount of freshwater for water cycle may be collected from atmospheric precipitation in some period or delivered. Prime soil is not a necessity because hydroponics allows us to achieve record harvests on any soil.

*The second important innovation* is using a cheap controlled heat conductivity, double-layer cover (controlled clarity is optionally needed for some regions). This innovation allows to conserve solar heat (in cold regions), to control temperature (in hot climates). That allows two to three rich crops annually in the Earth's middle latitudes and to conversion of the cold zones (Siberia, northern Canada, Alaska) to good single-crop regions.

*The third innovation* is control of the cover height, which allows adapting to local climatic seasons.

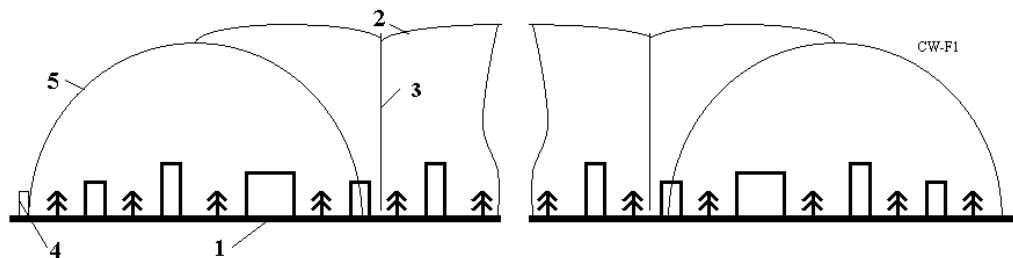


Figure 6-1. Film dome over agriculture region or a city. *Notations:* 1 - area, 2 - thin film cover with a control heat conductivity and clarity, 3 – control support cable and tubes for rain water (height is 50 – 300 m), 4 - exits and ventilators, 5 - semi-cylindrical border section.

*The fourth innovation* is the use of cheap, thin film as the high altitude cover. This innovation decreases the construction cost by thousands of times in comparison with the conventional very expensive glass-concrete domes offered by some for city use.

Lest it be objected that such domes would take impractical amounts of plastic, consider that the world's plastic production is today on the order of 100 million metric tons. If, with the expectation of future economic growth, this amount doubles over the next generation, and the increase is used for doming over territory at 500 tons a square kilometer, about 200,000 square kilometers could be roofed over annually. While small in comparison to the approximately 150 million square kilometers of land area, consider that 200,000 1 kilometer sites scattered over the face of the Earth made newly inhabitable could revitalize vast swaths of land surrounding them—one square kilometer could grow local vegetables for a city sited in the desert, one over there could grow bio-fuel, enabling a desolate South Atlantic island to become independent of costly fuel imports; at first, easily a billion people a year could be taken out of sweltering heat, biting cold and drenching rains, saving money that

purchase, installation and operation of HVAC equipment—heating, ventilation, air-conditioning—would require.

Our dome design is presented in Figure 1 includes the thin inflated film dome. The innovations are listed here: (1) the construction is air-inflatable; (2) each dome is fabricated with very thin, transparent film (thickness is 0.1 to 0.3 mm) having controlled clarity and controlled heat conductivity without rigid supports; (3) the enclosing film has two conductivity layers plus a liquid crystal layer between them which changes its clarity, color and reflectivity under an electric voltage (Figure 6-2); (4) the bounded section of the dome proposed that has a hemispheric shape (#5, Figure 6-1). The air pressure is greater in these sections, and they protect the central sections from wind outside.

Figure 1 illustrates the thin transparent control dome cover we envision. The inflated textile shell—technical “textiles” can be woven or films—embodies the innovations listed: (1) the film is very thin, approximately 0.1 to 0.3 mm., implying under 500 tons per square kilometer. A film this thin has never before been used in a major building; (2) the film has two strong nets, with a mesh of about  $0.1 \times 0.1$  m and  $a = 1 \times 1$  m, the threads are about 0.5 mm for a small mesh and about 1 mm for a big mesh. The net prevents the watertight and airtight film covering from being damaged by vibration; (3) the film incorporates a tiny electrically conductive wire net with a mesh of about  $0.1 \times 0.1$  m and a line width of about  $100 \mu$  and a thickness near  $10 \mu$ . The wire net is electric (voltage) control conductor. It can inform the dome maintenance engineers concerning the place and size of film damage (tears, rips); (4) the film may be twin-layered with the gap —  $c = 1$  m and  $b = 2$  m—between film layers for heat insulation. In Polar (and hot Tropic) regions this multi-layered covering is the main means for heat isolation and puncture of one of the layers wont cause a loss of shape because the second film layer is unaffected by holing; (5) the airspace in the dome’s covering can be partitioned, either hermetically or not; and (6) part of the covering can have a very thin shiny aluminum coating that is about  $1 \mu$  (micron) for reflection of unneeded sunlight in the equatorial region, or collect additional solar radiation in the polar regions [1].

The authors offer a method for moving off the accumulated snow and ice from the film in polar regions. After snowfall we decrease the heat cover protection, heating the snow (or ice) by warm air flowing into channels 5 (Figure 2) (between cover layers), and water runs down into tubes 3 (Figure 6-3).

The town cover may be used as a screen for projecting of pictures, films and advertising on the cover at nighttime.

### **Brief Data on Cover Film**

Our dome filmic cover has 5 layers (Figure 4c): transparant dielectric layer, conducting layer (about  $1 - 3 \mu$ ), liquid crystal layer (about  $10 - 100 \mu$ ), conducting layer (for example,  $\text{SnO}_2$ ), and transparant dielectric layer. Common thickness is  $0.1 - 0.5$  mm. Control voltage is  $5 - 10$  V. This film may be produced by industry relatively cheaply.

## **1. Liquid Crystals (LC)**

Liquid crystals (LC) are substances that exhibit a phase of matter that has properties between those of a conventional liquid, and those of a solid crystal.

Liquid crystals find general employment in liquid crystal displays (LCD), which rely on the optical properties of certain liquid crystalline molecules in the presence or absence of an electric field. On command, the electric field can be used to make a pixel switch between clear or dark. Color LCD systems use the same technique, with color filters used to generate red, green, and blue pixels. Similar principles can be used to make other liquid crystal-based optical devices. Liquid crystal in fluid form is used to detect electrically generated hotspots for failure analysis in the semiconductor industry.

Liquid crystal memory units with extensive capacity were used in the USA’s Space Shuttle navigation equipment. Worth noting also is the fact that many common fluids are, in fact, liquid

crystals. Soap, for instance, is a liquid crystal, and forms a variety of LC phases depending on its concentration in water.

The conventional control clarity (transparency) film reflected all superfluous energy to outer space. If the film has solar cells then it may convert the once superfluous solar energy into harnessed electricity.

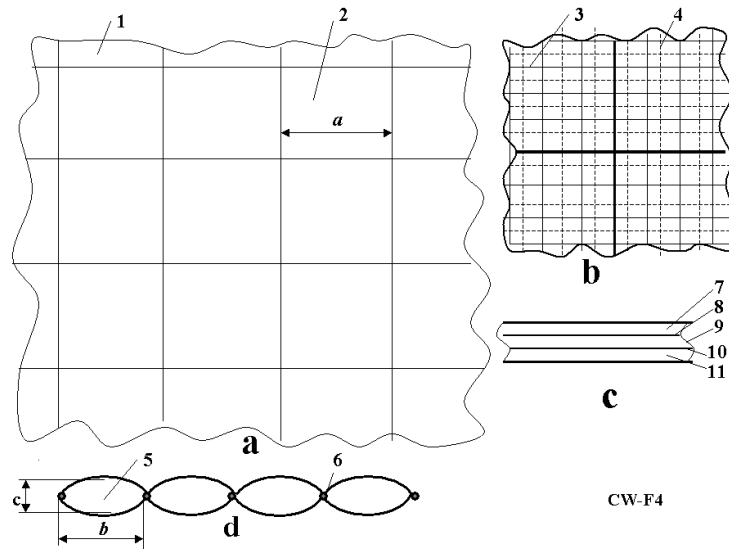


Figure 6-2. Design of membrane covering. *Notations:* (a) Big fragment of cover with control clarity (reflectivity, carrying capacity) and heat conductivity; (b) Small fragment of cover; (c) Cross-section of cover (film) having 5 layers; (d) Longitudinal cross-section of cover for cold and hot regions; 1 - cover; 2 - mesh; 3 - small mesh; 4 - thin electric net; 5 - cell of cover; 6 - tubes; 7 - transparent dielectric layer, 8 - conducting layer (about 1 - 3  $\mu$ ), 9 - liquid crystal layer (about 10 - 100  $\mu$ ), 10 - conducting layer, and 11 - transparent dielectric layer. Common thickness is 0.1 - 0.5 mm. Control voltage is 5 - 10 V.

## 2. Transparency

In optics, transparency is the material property of passing natural and artificial light through any material. Though transparency usually refers to visible light in common usage, it may correctly be used to refer to any type of radiation. Examples of transparent materials are air and some other gases, liquids such as water, most non-tinted glasses, and plastics such as Perspex and Pyrex. The degree of material transparency varies according to the wavelength of the light. From electrodynamics it results that only a vacuum is really transparent in the strictest meaning, any matter has a certain absorption for electromagnetic waves. There are transparent glass walls that can be made opaque by the application of an electric charge, a technology known as electrochromics. Certain crystals are transparent because there are straight-lines through the crystal structure. Light passes almost unobstructed along these lines. There exists a very complicated scientific theory "predicting" (calculating) absorption and its spectral dependence of different materials.

## 3. Electrochromism

*Electrochromism* is the phenomenon displayed by some chemical species of reversibly changing color when a burst of electric charge is applied.

One good example of an electrochromic material is polyaniline which can be formed either by the electrochemical or chemical oxidation of aniline. If an electrode is immersed in hydrochloric acid which contains a small concentration of aniline, then a film of polyaniline can be grown on the electrode. Depending on the redox state, polyaniline can either be pale yellow or dark green/black. Other electrochromic materials that have found technological application include the viologens and

polyoxotungstates. Other electrochromic materials include tungsten oxide ( $\text{WO}_3$ ), which is the main chemical used in the production of electrochromic windows or smart windows.

As the color change is persistent and energy need only be applied to effect a change, electrochromic materials are used to control the amount of light and heat allowed to pass through windows ("smart windows"), and has also been applied in the automobile industry to automatically tint rear-view mirrors in various lighting conditions. Viologen is used in conjunction with titanium dioxide ( $\text{TiO}_2$ ) in the creation of small digital displays. It is hoped that these will replace LCDs as the viologen (which is typically dark blue) has a high contrast to the bright color of the titanium white, therefore providing a high visibility of the display.

## **Conclusion**

One half of Earth's human population is chronically malnourished. *The majority of Earth's surface area is not suitable for unshielded human life.* The increasing of agriculture area, crop capacity, carrying capacity by means of converting the deserts, desolate wildernesses, taiga, tundra permafrost into gardens are an important escape-hatch from some of humanity's most pressing macro-problems. The offered cheapest ( $\$0.1 \div 0.3/\text{m}^2$ ) AB method may dramatically increase the potentially realizable sown area, crop capacity; indeed the range of territory suitable for human living. In theory, converting all Earth land such as Alaska, northern Canada, Siberia, or the Sahara or Gobi deserts into prosperous gardens would be the equivalent of colonizing another Solar System planet. The suggested method is very cheap (cost of covering 1  $\text{m}^2$  is about 10 - 30 USA cents) and may be utilized immediately. We can start from small regions, such as towns in bad regions and, gradually, extend the practice over a large region—and what is as important, earning monetary profits most of the time.

Filmic domes can foster the fuller economic development of dry, hot, and cold regions such as the Earth's Arctic and Antarctic, the Sahara and, thus, increase the effective area of territory dominated by 21<sup>st</sup> Century humans. Normal human health can be maintained by ingestion of locally grown fresh vegetables and healthful "outdoor" exercise. The domes can also be used in the Tropics and Temperate Zone. Eventually, technical adaptations may find application on the Moon or Mars since a vertical variant, inflatable towers to outer space, are soon to become available for launching spacecraft inexpensively into Earth-orbit or interplanetary flights [12].

The related problems are researched in references [1]-[12].

Let us shortly summarize some advantages of this offered AB Dome method of climate moderation:

- (1) Method does not need large amounts of constant input freshwater for irrigation;
- (2) Low cost of inflatable filmic Dome per area reclaimed: (10 - 30 cents/ $\text{m}^2$ );
- (3) Control of inside temperature is total;
- (4) Usable in very hot and cool climate regions;
- (5) Covered region is not at risk from exterior weather;
- (6) Possibility of flourishing crops even with a sterile hydroponics soil;
- (7) 2 – 3 harvests each year; without farmers' extreme normal risks.
- (8) Rich harvests, at that.
- (9) Converting deserts, desolate wildernesses, taiga, tundra, permafrost terrain, and the ocean into gardens;
- (10) Covering towns and cities with low-cost, even picturesque domes;
- (11) Using the dome cover for income-generating neighborhood illumination, picture displays, movies and videos as well as paid advertising.

We can concoct generally agreeable local weather and settle new territory for living with an agreeable climate (without daily rain, wind and low temperatures) for agriculture. By utilizing thin film, gigantic territorial expanses of dry and cold regions can be covered. Countries having big

territory (but also much bad land) may be able to use domes to increase their population and became powerful states during the 21<sup>st</sup> Century.

The offered method may be used to conserve a vanishing sea such as the Aral Sea or the Dead Sea. A closed-loop water cycle could save these two seas for a future generation of people, instead of bequeathing a salty dustbowl.

A.A. Bolonkin has further developed the same method for the ocean. By controlling the dynamics and climate there, oceanic colonies may increase the Earth's humanly useful region another three times concurrent with or after the doubling of useful land outlined above. Our outlined method would allow the Earth's human population to increase by 5 – 10 times, without the starvation.

The offered method can solve the problem of apparent problem of global warming because the AB domes will be able to confine until use much carbon dioxide gas which appreciably increases a harvest. This carbon dioxide gas will show up in yet more productive crop harvests! The dome lift-force reaches up to 300 kg/m<sup>2</sup>. The telephone, TV, electric, water and other communications can be suspended from the dome cover.

The offered method can also help to defend cities (or an entire given region) from rockets, nuclear warheads, and military aviation. Details are offered in a later chapter. This method may be applied to other planets and satellites as Moon and Mars.

## **7. Artificial Explosion of Sun and AB-Criterion for Solar Detonation\***

The Sun contains ~74% hydrogen by weight. The isotope hydrogen-1 (99.985% of hydrogen in nature) is a usable fuel for fusion thermonuclear reactions.

This reaction runs slowly within the Sun because its temperature is low (relative to the needs of nuclear reactions). If we create higher temperature and density in a limited region of the solar interior, we may be able to produce self-supporting detonation thermonuclear reactions that spread to the full solar volume. This is analogous to the triggering mechanisms in a thermonuclear bomb. Conditions within the bomb can be optimized in a small area to initiate ignition, then spread to a larger area, allowing producing a hydrogen bomb of any power. In the case of the Sun certain targeting practices may greatly increase the chances of an artificial explosion of the Sun. This explosion would annihilate the Earth and the Solar System, as we know them today.

The reader naturally asks: Why even contemplate such a horrible scenario? It is necessary because as thermonuclear and space technology spreads to even the least powerful nations in the centuries ahead, a dying dictator having thermonuclear missile weapons can produce (with some considerable mobilization of his military/industrial complex)— an artificial explosion of the Sun and take into his grave the whole of humanity. It might take tens of thousands of people to make and launch the hardware, but only a very few need know the final targeting data of what might be otherwise a weapon purely thought of (within the dictator's defense industry) as being built for peaceful, deterrent use.

Those concerned about Man's future must know about this possibility and create some protective system—or ascertain on theoretical grounds that it is entirely impossible.

Humanity has fears, justified to greater or lesser degrees, about asteroids, warming of Earthly climate, extinctions, etc. which have very small probability. But all these would leave survivors -- nobody thinks that the terrible annihilation of the Solar System would leave a single person alive. That explosion appears possible at the present time. In this paper is derived the 'AB-Criterion' which shows conditions wherein the artificial explosion of Sun is possible. The author urges detailed investigation and proving or disproving of this rather horrifying possibility, so that it may be dismissed from mind—or defended against.

-----  
 \* This work is written together J. Friedlander. He corrected the author's English, wrote together with author Abstract, Sections 8, 10 ("Penetration into Sun" and "Results"), and wrote Section 11 "Discussion" as the solo author. See also [4] Ch.10.

## Statement of Problem, Main Idea and Our Aim

The present solar temperature is far lower than needed for propagating a runaway thermonuclear reaction. In Sun core the temperature is only  $\sim 13.6$  MK (0.0012 MeV). The Coulomb barrier for protons (hydrogen) is more than 0.4 MeV. Only very small proportions of core protons take part in the thermonuclear reaction (they use a tunnelling effect). Their energy is in balance with energy emitted by Sun for the Sun surface temperature 5785 K (0.5 eV).

We want to clarify: If we create a zone of limited size with a high temperature capable of overcoming the Coulomb barrier (for example by insertion of a thermonuclear warhead) into the solar photosphere (or lower), can this zone ignite the Sun's photosphere (ignite the Sun's full load of thermonuclear fuel)? Can this zone self-support progressive runaway reaction propagation for a significant proportion of the available thermonuclear fuel?

If it is possible, researchers can investigate the problems: What will be the new solar temperature? Will this be metastable, decay or runaway? How long will the transformed Sun live, if only a minor change? What the conditions will be on the Earth?

Why is this needed?

As thermonuclear and space technology spreads to even the least powerful nations in the decades and centuries ahead, a dying dictator having thermonuclear weapons and space launchers can produce (with some considerable mobilization of his military/industrial complex)—the artificial explosion of the Sun and take into his grave the whole of humanity.

It might take tens of thousands of people to make and launch the hardware, but only a very few need know the final targeting data of what might be otherwise a weapon purely thought of (within the dictator's defense industry) as being built for peaceful, 'business as usual' deterrent use. Given the hideous history of dictators in the twentieth century and their ability to kill technicians who had outlived their use (as well as major sections of entire populations also no longer deemed useful) we may assume that such ruthlessness is possible.

Given the spread of suicide warfare and self-immolation as a desired value in many states, (in several cultures—think Berlin or Tokyo 1945, New York 2001, Tamil regions of Sri Lanka 2006) what might obtain a century hence? All that is needed is a supportive, obedient defense complex, a 'romantic' conception of mass death as an ideal—even a religious ideal—and the realization that his own days at power are at a likely end. It might even be launched as a trump card in some (to us) crazy internal power struggle, and plunged into the Sun and detonated in a mood of spite by the losing side. *'Burn baby burn'!*

A small increase of the average Earth's temperature over 0.4 K in the course of a century created a panic in humanity over the future temperature of the Earth, resulting in the Kyoto Protocol. Some stars with active thermonuclear reactions have temperatures of up to 30,000 K. If not an explosion but an enhanced burn results the Sun might radically increase in luminosity for—say—a few hundred years. This would suffice for an average Earth temperature of hundreds of degrees over 0 C. The oceans would evaporate and Earth would bake in a Venus like greenhouse, or even lose its' atmosphere entirely.

Thus we must study this problem to find methods of defense from human induced Armageddon. The interested reader may find needed information in [4] Ch.10, Ref. [1]-[4].

## Results of research

The Sun contains 73.46 % hydrogen by weight. The isotope hydrogen-1 (99.985% of hydrogen in nature) is usable fuel for a fusion thermonuclear reaction.

The p-p reaction runs slowly within the Sun because its temperature is low (relative to the temperatures of nuclear reactions). If we create higher temperature and density in a limited region of the solar interior, we may be able to produce self-supporting, more rapid detonation thermonuclear reactions that may spread to the full solar volume. This is analogous to the triggering mechanisms in a thermonuclear bomb. Conditions within the bomb can be optimized in a small area to initiate ignition, build a spreading reaction and then feed it into a larger area, allowing producing a ‘solar hydrogen bomb’ of any power—but not necessarily one whose power can be limited. In the case of the Sun certain targeting practices may greatly increase the chances of an artificial explosion of the entire Sun. This explosion would annihilate the Earth and the Solar System, as we know them today.

Author A.A. Bolonkin has researched this problem and shown that an artificial explosion of Sun cannot be precluded. In the Sun’s case this lacks only an initial fuse, which induces the self-supporting detonation wave. This research has shown that a thermonuclear bomb exploded within the solar photosphere surface may be the fuse for an accelerated series of hydrogen fusion reactions.

The temperature and pressure in this solar plasma may achieve a temperature that rises to billions of degrees in which all thermonuclear reactions are accelerated by many thousands of times. This power output would further heat the solar plasma. Further increasing of the plasma temperature would, in the worst case, climax in a solar explosion.

The possibility of initial ignition of the Sun significantly increases if the thermonuclear bomb is exploded under the solar photosphere surface. The incoming bomb has a diving speed near the Sun of about 617 km/sec. Warhead protection to various depths may be feasible –ablative cooling which evaporates and protects the warhead some minutes from the solar temperatures. The deeper the penetration before detonation the temperature and density achieved greatly increase the probability of beginning thermonuclear reactions which can achieve explosive breakout from the current stable solar condition.

Compared to actually penetrating the solar interior, the flight of the bomb to the Sun, (with current technology requiring a gravity assist flyby of Jupiter to cancel the solar orbit velocity) will be easy to shield from both radiation and heating and melting. Numerous authors, including A.A. Bolonkin in works [7]-[12] offered and showed the high reflectivity mirrors which can protect the flight article within the orbit of Mercury down to the solar surface.

The author A.A. Bolonkin originated the AB Criterion, which allows estimating the condition required for the artificial explosion of the Sun.

## Discussion

If we (humanity—unfortunately in this context, an insane dictator representing humanity for us) create a zone of limited size with a high temperature capable of overcoming the Coulomb barrier (for example by insertion of a specialized thermonuclear warhead) into the solar photosphere (or lower), can this zone ignite the Sun’s photosphere (ignite the Sun’s full load of thermonuclear fuel)? Can this zone self-support progressive runaway reaction propagation for a significant proportion of the available thermonuclear fuel?

If it is possible, researchers can investigate the problems: What will be the new solar temperature? Will this be metastable, decay or runaway? How long will the transformed Sun live, if only a minor change? What the conditions will be on the Earth during the interval, if only temporary? If not an



explosion but an enhanced burn results the Sun might radically increase in luminosity for –say--a few hundred years. This would suffice for an average Earth temperature of hundreds of degrees over 0 °C. The oceans would evaporate and Earth would bake in a Venus like greenhouse, or even lose its' atmosphere entirely.

It would not take a full scale solar explosion, to annihilate the Earth as a planet for Man. (For a classic report on what makes a planet habitable, co-authored by Issac Asimov, see [http://www.rand.org/pubs/commercial\\_books/2007/RAND\\_CB179-1.pdf](http://www.rand.org/pubs/commercial_books/2007/RAND_CB179-1.pdf) 0.

Converting the sun even temporarily into a ‘superflare’ star, (which may hugely vary its output by many percent, even many times) over very short intervals, not merely in heat but in powerful bursts of shorter wavelengths) could kill by many ways, notably ozone depletion—thermal stress and atmospheric changes and hundreds of others of possible scenarios—in many of them, human civilization would be annihilated. And in many more, humanity as a species would come to an end.

The reader naturally asks: Why even contemplate such a horrible scenario? It is necessary because as thermonuclear and space technology spreads to even the least powerful nations in the centuries ahead, a dying dictator having thermonuclear missile weapons can produce (with some considerable mobilization of his military/industrial complex)—the artificial explosion of the Sun and take into his grave the whole of humanity. It might take tens of thousands of people to make and launch the hardware, but only a very few need know the final targeting data of what might be otherwise a weapon purely thought of (within the dictator’s defense industry) as being built for peaceful, deterrent use.

Those concerned about Man’s future must know about this possibility and create some protective system—or ascertain on theoretical grounds that it is entirely impossible, which would be comforting.

Suppose, however that some variation of the following is possible, as determined by other researchers with access to good supercomputer simulation teams. What, then is to be done?

The action proposed depends on what is shown to be possible.

Suppose that no such reaction is possible—it dampens out unnoticeably in the solar background, just as no fission bomb triggered fusion of the deuterium in the oceans proved to be possible in the Bikini test of 1946. This would be the happiest outcome.

Suppose that an irruption of the Sun’s upper layers enough to cause something operationally similar to a targeted ‘coronal mass ejection’ – CME-- of huge size targeted at Earth or another planet? Such a CME like weapon could have the effect of a huge electromagnetic pulse. Those interested should look up data on the 1859 solar superstorm, the Carrington event, and the Stewart Super Flare. Such a CME/EMP weapon might target one hemisphere while leaving the other intact as the world turns. Such a disaster could be surpassed by another step up the escalation ladder-- by a huge hemisphere killing thermal event of ~12 hours duration such as postulated by science fiction writer Larry Niven in his 1971 story "Inconstant Moon"—apparently based on the Thomas Gold theory (ca. 1969-70) of rare solar superflares of 100 times normal luminosity. Subsequent research<sup>18</sup> (Wdowczyk and Wolfendale, 1977) postulated horrific levels of solar activity, ozone depletion and other such consequences might cause mass extinctions. Such an improbable event might not occur naturally, but could it be triggered by an interested party? A triplet of satellites monitoring at all times both the sun from Earth orbit and the ‘far side’ of the Sun from Earth would be a good investment both scientifically and for purposes of making sure no ‘creative’ souls were conducting trial CME eruption tests!

Might there be peaceful uses for such a capability? In the extremely hypothetical case that a yet greater super-scale CME could be triggered towards a given target in space, such a pulse of denser than naturally possible gas might be captured by a giant braking array designed for such a purpose to provide huge stocks of hydrogen and helium at an asteroid or moon lacking these materials for purposes of future colonization.

A worse weapon on the scale we postulate might be an asymmetric eruption (a form of directed thermonuclear blast using solar hydrogen as thermonuclear fuel), which shoots out a coherent (in the sense of remaining together) burst of plasma at a given target without going runaway and consuming the outer layers of the Sun. If this quite unlikely capability were possible at all (dispersion issues argue against it—but before CMEs were discovered, they too would have seemed unlikely), such an apocalyptic ‘demo’ would certainly be sufficient emphasis on a threat, or a means of warfare against a colonized solar system. With a sufficient thermonuclear burn—and if the condition of nondispersion is fulfilled—might it be possible to literally strip a planet—Venus, say—of its’ atmosphere? (It might require a mass of fusion fuel—and a hugely greater non-fused expelled mass comparable in total to the mass to be stripped away on the target planet.)

It is not beyond the limit of extreme speculation to imagine an expulsion of this order sufficient to strip Jupiter’s gas layers off the ‘Super-Earth’ within. —To strip away 90% or more of Jupiter’s mass (which otherwise would take perhaps ~400 Earth years of total solar output to disassemble with perfect efficiency and neglecting waste heat issues). It would probably waste a couple Jupiter masses of material (dispersed hydrogen and helium). It would be an amazing engineering capability for long term space colonization, enabling substantial uses of materials otherwise unobtainable in nearly all scenarios of long term space civilization.

Moving up on the energy scale-- “boosting” or “damping” a star, pushing it into a new metastable state of greater or lesser energy output for times not short compared with the history of civilization, might be a very welcome capability to colonize another star system—and a terrifying reason to have to make the trip.

And of course, in the uncontrollable case of an induced star explosion, in a barren star system it could provide a nebula for massive mining of materials to some future super-civilization. It is worth noting in this connection that the Sun constitutes 99.86 percent of the material in the Solar System, and Jupiter another .1 percent. Literally a thousand Earth masses of solid (iron, carbon) building materials might be possible, as well as thousands of oceans of water to put inside space colonies in some as yet barren star system.

But here in the short-term future, in our home solar system, such a capability would present a terrible threat to the survival of humanity, which could make our own solar system completely barren.

The list of possible countermeasures does not inspire confidence. A way to interfere with the reaction (dampen it once it starts)? It depends on the spread time, but seems most improbable. We cannot even stop nuclear reactions once they take hold on Earth—the time scales are too short.

Is defense of the Sun possible? Unlikely—such a task makes missile defense of the Earth look easy. Once a gravity assist Jupiter flyby nearly stills the velocity with which a flight article orbits the Sun, it will hang relatively motionless in space and then begin the long fall to fiery doom. A rough estimate yields only one or two weeks to intercept it within the orbit of Mercury, and the farther it falls the faster it goes, to science fiction-like velocities sufficient to reach Pluto in under six weeks before it hits.

A perimeter defense around the Sun? The idea seems impractical with near term technology.

The Sun is a hundred times bigger sphere than Earth in every dimension. If we have 10,000 ready to go interceptor satellites with extreme sunshields that function a few solar radii out each one must be able to intercept with 99% probability the brightening light heading toward its’ sector of the Sun over a circle the size of Earth, an incoming warhead at around 600 km/sec.

If practical radar range from a small set is considered (4th power decline of echo and return) as 40,000 km then only 66 seconds would be available to plot a firing solution and arm for a destruct attempt. More time would be available by a telescope looking up for brightening, infalling objects—but there are many natural incoming objects such as meteors, comets, etc. A radar might be needed just

to confirm the artificial nature of the in-falling object (given the short actuation time and the limitations of rapid storable rocket delta-v some form of directed nuclear charge might be the only feasible countermeasure) and any leader would be reluctant to authorize dozens of nuclear explosions per year automatically (there would be no time to consult with Earth, eight light-minutes away—and eight more back, plus decision time). But the cost of such a system, the reliability required to function endlessly in an area in which there can presumably be no human visits and the price of its' failure, staggers the mind. And such a 'thin' system would be not difficult to defeat by a competent aggressor...

A satellite system near Earth for destroying the rockets moving to the Sun may be a better solution, but with more complications, especially since it would by definition also constitute an effective missile defense and space blockade. Its' very presence may help spark a war. Or if only partially complete but under construction, it may invite preemption, perhaps on the insane scale that we here discuss...

Astronomers see the explosion of stars. They name these stars novae and supernovae—"New Stars" and try to explain (correctly, we are sure, in nearly all cases) their explosion by natural causes. But some few of them, from unlikely spectral classifications, may be result of war between civilizations or fanatic dictators inflicting their final indignity upon those living on planets of the given star. We have enough disturbed people, some in positions of influence in their respective nations and organizations and suicide oriented violent people on Earth. But a nuclear bomb can destroy only one city. A dictator having possibility to destroy the Solar System as well as Earth can blackmail all countries—even those of a future Kardashev scale 2 star-system wide civilization-- and dictate his will/demands on any civilized country and government. It would be the reign of the crazy over the sane.

Author A.A. Bolonkin already warned about this possibility in 2007 (see his interview [http://www.pravda.ru/science/planet/space/05-01-2007/208894-sun\\_detonation-0](http://www.pravda.ru/science/planet/space/05-01-2007/208894-sun_detonation-0) [4] Ch.10, Ref. [15] (in Russian) (A translation of this is appended at the end of this article) and called upon scientists and governments to research and develop defenses against this possibility. But some people think the artificial explosion of Sun impossible. This led to this current research to give the conditions where such detonations are indeed possible. That shows that is conceivably possible even at the present time using current rockets and nuclear bombs—and only more so as the centuries pass. Let us take heed, and know the risks we face—or disprove them.

The first information about this work was published in [4] Ch.10, Ref. [15]. This work produced the active Internet discussion in [4] Ch.10, Ref. [19]. Among the raised questions were the following:

1) It is very difficult to deliver a warhead to the Sun. The Earth moves relative to the Sun with a orbital velocity of 30 km/s, and this speed should be cancelled to fall to the Sun. Current rockets do not suffice, and it is necessary to use gravitational maneuvers around planets. For this reason (high delta-V (velocity changes required) for close solar encounters, the planet Mercury is so badly investigated (probes there are expensive to send).

*Answer:* The Earth has a speed of 29 km/s around the Sun and an escape velocity of only 11 km/s. But Jupiter has an orbital velocity of only 13 km/sec and an escape velocity of 59.2 km/s. Thus, the gravity assist Jupiter can provide is more than the Earth can provide, and the required delta-v at that distance from the Sun far less—enough to entirely cancel the sun-orbiting velocity around the Sun, and let it begin the long plunge to the Solar orb at terminal velocity achieving Sun escape speed 617.6 km/s. Notice that for many space exploration maneuvers, we require a flyby of Jupiter, exactly to achieve such a gravity assist, so simply guarding against direct launches to the Sun from Earth would be futile!

2) Solar radiation will destroy any a probe on approach to the Sun or in the upper layers of its photosphere.

*Answer:* It is easily shown, the high efficiency AB-reflector can full protection the apparatus. See [1] Chapters 12, 3A, [2] Ch.5, ref. [9]-[12].

3) The hydrogen density in the upper layers of the photosphere of the Sun is insignificant, and it would be much easier to ignite hydrogen at Earth oceans if it in general is possible.

*Answer:* The hydrogen density is enough known. The Sun has gigantic advantage – that is PLASMA. Plasma of sufficient density reflects or blocks radiation—it has opacity. That means: **no radiation losses in detonation**. It is very important for heating. The AB Criterion in this paper is received for PLASMA. Other planets of Solar system have MOLECULAR atmospheres which passes radiation. No sufficient heating – no detonation! The water has higher density, but water passes the high radiation (for example  $\gamma$ -radiation) and contains a lot of oxygen (89%), which may be bad for the thermonuclear reaction. This problem needs more research.

## Summary

This is only an initial investigation. Detailed supercomputer modeling which allows more accuracy would greatly aid prediction of the end results of a thermonuclear explosion on the solar photosphere.

Author invites the attention of scientific society to detailed research of this problem and devising of protection systems if it proves a feasible danger that must be taken seriously.

## References

Many works noted below the reader can find on site Cornell University <<http://arxiv.org/>>, sites <<http://www.scribd.com>>, <<http://www.archive.org>> search "Bolonkin", <<http://bolonkin.narod.ru/p65.htm>> and in Conferences 2002-2006 (see, for example, Conferences AIAA, <<http://aiaa.org/>>, search "Bolonkin" ).

1. Bolonkin A.A., (2006)"Non-Rocket Space Launch and Flight", Elsevier, 2005, 408 p.  
<http://www.archive.org/details/Non-rocketSpaceLaunchAndFlight>,  
<http://www.scribd.com/doc/24056182>
2. Bolonkin A.A. (2006), Book "New Concepts, Ideas and Innovation in Aerospace", NOVA, 2008.<http://www.scribd.com/doc/24057071> .  
<http://www.archive.org/details/NewConceptsIfeasAndInnovationsInAerospaceTechnologyAndHumanSciences>
3. Bolonkin A.A. (2007), "Macro-Engineering: Environment and Technology", pp. 299-334, NOVA, 2008.  
<http://Bolonkin.narod.ru/p65.htm>, <http://www.scribd.com/doc/24057930> .  
<http://www.archive.org/details/Macro-projectsEnvironmentsAndTechnologies>
4. Bolonkin A.A. (2008), "New Technologies and Revolutionary Projects", Scribd, 2008, 324 pgs,  
<http://www.scribd.com/doc/32744477> ,  
<http://www.archive.org/details/NewTechnologiesAndRevolutionaryProjects> .
5. Bolonkin A.A., Space Elevator. This manuscript was presented by author as paper IAC-02-V.P.07 at the World Space Congress-2002, Oct.10-19, Houston, TX, USA and published in *JBIS*, vol. 56, No. 7/8, 2003, pp. 231–249. See also Bolonkin A.A., (2005) "Non-Rocket Space Launch and Flight", Elsevier, 2005, Ch.1,  
<http://www.archive.org/details/Non-rocketSpaceLaunchAndFlight>, <http://www.scribd.com/doc/24056182>.
6. Bolonkin A.A., Man in space without space suite, American Journal of Engineering and Applied Sciences, Vol.2, #4, pp.573-579, 2009. <http://www.scipub.org/fulltext/ajea/ajeas24573-579> .  
Published also in [1] Ch.19 (2005); in [4] Ch.6, (2009).
7. Bolonkin A.A., Electrostatic levitation and artificial gravity. Presented as paper AIAA-2005-4465 at 41 Propulsion Conference, 10–13 July 2005, Tucson, Arizona, USA. See also [1], Ch.15 pp.281-302.

8. Bolonkin A.A., A New Method of Atmospheric Reentry for Space Ships. Presented as paper AIAA-2006-6985 to Multidisciplinary Analysis and Optimization Conference, 6-8 Sept. 2006, Portsmouth. See also [2] Ch.8, pp.153-160.
9. Bolonkin A.A., Inflatable Dome for Moon, Mars, Asteroids and Satellites. Presented as paper AIAA-2007-6262 to AIAA Conference "Space-2007", 18-20 September 2007, Long Beach, CA, USA. Published as Inflatable Dome for Moon, Mars, Asteroids and Satellites in <http://arxiv.org> <http://arxiv.org/ftp/arxiv/papers/0707/0707.3990.pdf> . See also [3] Ch.2, pp.35-50.
10. Bolonkin A.A., AB Method of Irrigation on planet without Water (Closed-loop Water Cycle). Presented in electronic library of Cornell University <http://arxiv.org> in 27 December 2007. <http://arxiv.org/ftp/arxiv/papers/0712/0712.3935.pdf> . See also [3] Ch.1, pp. 3-34.
11. Bolonkin A.A., Artificial Explosion of Sun and AB-Criterion for Solar Detonation. See [4] Ch.10.
12. Bolonkin A.A., (2006). Electrostatic AB-Ramjet Space Propulsion. <http://arxiv.org/ftp/physics/papers/0701/0701073.pdf>
13. Bolonkin A.A., (2009). Magnetic Space AB-Accelerator. <http://www.scribd.com/doc/26885058>
14. Bolonkin A.A., (2009). Converting of any Matter to Nuclear Energy by AB-Generator and Aerospace. <http://www.archive.org/details/ConvertingOfAnyMatterToNuclearEnergyByAb-generatorAndAerospace>.  
American Journal of Engineering and Applied Science, Vol. 2, #4, 2009, pp.683-693.  
<http://www.scipub.org/fulltext/ajeas/ajeas24683-693.pdf> .
15. Bolonkin A.A., (2009). Femtotechnology: Design of the Strongest AB-Matter for Aerospace. <http://www.archive.org/details/FemtotechnologyDesignOfTheStrongestAb-matterForAerospace> .  
American Journal of Engineering and Applied Science, Vol. 2, #2, 2009, pp.501-514.  
<http://www.scipub.org/fulltext/ajeas/ajeas22501-514.pdf> .
16. Bolonkin A.A., (2009). Magnetic Space AB-Accelerator. <http://www.scribd.com/doc/26885058>
17. Bolonkin A.A., Magnetic Suspended AB-Structures and Moveless Space Satellites. <http://www.scribd.com/doc/25883886> .
18. Bolonkin A.A., LIFE. SCIENCE. FUTURE (Biography notes, researches and innovations). Scribd, 2010, 208 pgs.  
16 Mb. <http://www.archive.org/details/Life.Science.Future.biographyNotesResearchesAndInnovations>,  
<http://www.scribd.com/doc/48229884>,
19. Bolonkin A.A., Robot as Person. Personhood. Three Prerequisites or Laws of Robots. <http://www.archive.org/details/RobotAsPersonpersonhood.ThreePrerequisitesOrLawsOfRobots>
20. Bolonkin A.A., Krinker M., Magnetic-Space-Launcher. <http://www.scribd.com/doc/24051286/>  
<http://arxiv.org/ftp/arxiv/papers/0903/0903.5008.pdf> .
21. Pensky O.G., Monograph "Mathematical Models of Emotional Robots", Perm, 2010, 193 ps (in English and Russian) (<http://arxiv.org/ftp/arxiv/papers/1011/1011.1841.pdf> ).
22. Pensky O.G., K. V. Chernikov "Fundamentals of Mathematical Theory of Emotional Robots " (<http://www.scribd.com/doc/40640088/>).
23. *Wikipedia*. Some background material in this article is gathered from Wikipedia under the Creative Commons license. <http://wikipedia.org> .  
2010





One of project space ship



Space launcher Orion

**Part B**  
**Projects solvable by current technology**



## Chapter 1B

# Aerial Gas Pipeline

### Abstract

Design of new cheap aerial pipelines, a large flexible tube deployed at high altitude, for delivery of natural (fuel) gas, water and other payload over a long distance is delineated. The main component of the natural gas is methane which has a specific weight less than air. A lift force of one cubic meter of methane equals approximately 0.5 kg (1 pound). The lightweight film flexible pipeline can be located in air at high altitude and, as such, does not damage the environment. Using the lift force of this pipeline and wing devices payloads of oil, water, or other fluids, or even solids such as coal, cargo, passengers can be delivered cheaply at long distance. This aerial pipeline dramatically decreases the cost and the time of construction relative to conventional pipelines of steel which saves energy and greatly lowers the capital cost of construction.

The article contains a computed project for delivery 24 billion cubic meters of gas and tens of million tons of oil, water or other payload per year.

**Key words:** gas pipeline, water pipeline, aerial pipeline, cheap pipeline, altitude pipeline, inflatable pipeline.

\*Presented in <http://arxiv.org>, 2008, search “Bolonkin”,

### Introduction

Natural gas is a gaseous fossil fuel consisting primarily of methane (CH<sub>4</sub>) but including significant quantities of ethane, propane, butane, and pentane—heavier hydrocarbons removed prior to use as a consumer fuel—as well as carbon dioxide, nitrogen, helium and hydrogen sulfide. Before natural gas can be used as a fuel, it must undergo extensive processing to remove almost all materials other than methane. The by-products of that processing include ethane, propane, butanes, pentanes and higher molecular weight hydrocarbons, elemental sulfur, and sometimes helium and nitrogen.

Natural gas is not only cheaper, but burns cleaner than other fossil fuels, such as oil and coal, and produces less carbon dioxide per unit energy released. For an equivalent amount of heat, burning natural gas produces about 30% less carbon dioxide than burning petroleum and about 45% less than burning coal.

The major difficulty in the use of natural gas is transportation and storage because of its low density. Natural gas conventional pipelines are economical, but they are impractical across oceans. Many existing pipelines in North America are close to reaching their capacity, prompting some politicians representing colder areas to speak publicly of potential shortages.

With 15 nations accounting for 84% of the world-wide production, access to natural gas has become a significant factor in international economics and politics. The world's largest gas field by far is Qatar's offshore North Field, estimated to have 25 trillion cubic meters ( $9.0 \times 10^{14}$  cu ft) of gas in place—enough to last more than 200 years at optimum production levels. The second largest natural gas field is the South Pars Gas Field in Iranian waters in the Persian Gulf. Connected to Qatar's North Field, it has estimated reserves of 8 to 14 trillion cubic meters ( $2.8 \times 10^{14}$  to  $5.0 \times 10^{14}$  cu ft) of gas.

In the past, the natural gas which was recovered in the course of recovering petroleum could not be profitably sold, and was simply burned at the oil field (known as flaring). This wasteful practice is now illegal in many countries. Additionally, companies now recognize that value for the gas may be achieved with liquefied natural gas (LNG), compressed natural gas (CNG), or other transportation methods to end-users in the future. LNG carriers can be used to transport (LNG) across oceans, while tank trucks can carry liquefied or CNG over shorter distances. They may transport natural gas directly

to end-users, or to distribution points such as pipelines for further transport. These may have a higher cost, requiring additional facilities for liquefaction or compression at the production point, and then gasification or decompression at end-use facilities or into a pipeline.

Pipelines are generally the most economical way to transport large quantities of oil or natural gas over land. Compared to railroad, they have lower cost per unit and also higher capacity. Although pipelines can be built under the sea, that process is economically and technically demanding, so the majority of oil at sea is transported by tanker ships. The current supertankers include Very Large Crude Carriers and Ultra Large Crude Carriers. Because, when full, some of the large supertankers can dock only in deepwater ports, they are often lightened by transferring the petroleum in small batches to smaller tankers, which then bring it into port. On rivers, barges are often used to transport petroleum.

Pipelines, most commonly transport liquid and gases, but pneumatic tubes that transport solid capsules using compressed air have also been used. Transportation pressure is generally 1,000 pounds per square inch (70 kilograms per square centimeter up to 220 atm) because transportation costs are lowest for pressures in this range. Pipeline diameters for such long-distance transportation have tended to increase from an average of about 24 to 29 inches (60 to 70 centimeters) in 1960 to about 4 feet (1.20 meters). Some projects involve diameters of more than 6 1/2 feet (2 meters). Because of pressure losses, the pressure is boosted every 50 or 60 miles (80 or 100 kilometers) to keep a constant rate of flow.

Oil pipelines are made from steel or plastic tubes with inner diameter typically from 10 to 120 cm (about 4 to 48 inches). Most pipelines are buried at a typical depth of about 1 - 2 metres (about 3 to 6 feet). The oil is kept in motion by pump stations along the pipeline, and usually flows at speed of about 1 to 6 m/s.

For natural gas, pipelines are constructed of carbon steel and varying in size from 2 inches (51 mm) to 56 inches (1,400 mm) in diameter, depending on the type of pipeline. The gas is pressurized by compressor stations and is odorless unless mixed with a mercaptan odorant where required by the proper regulating body. Pumps for liquid pipelines and Compressors for gas pipelines, are located along the line to move the product through the pipeline. The location of these stations is defined by the topography of the terrain, the type of product being transported, or operational conditions of the network.

Block Valve Station is the first line of protection for pipelines. With these valves the operator can isolate any segment of the line for maintenance work or isolate a rupture or leak. Block valve stations are usually located every 20 to 30 miles (48 km), depending on the type of pipeline.

Conventional pipelines can be the target of theft, vandalism, sabotage, or even terrorist attacks. In war, pipelines are often the target of military attacks, as destruction of pipelines can seriously disrupt enemy logistics.

The ground gas and oil pipeline significantly damage the natural environment, but as the demand is so great, ecological concerns are over-ridden by economic factors.

#### Increased Demand for Natural Gas

Natural gas is a major source of electricity generation through the use of gas turbines and steam turbines. Particularly high efficiencies can be achieved through combining gas turbines with a steam turbine in combined cycle mode. Combined cycle power generation using natural gas is the cleanest source of power available using fossil fuels, and this technology is widely used wherever gas can be obtained at a reasonable cost. Fuel cell technology may eventually provide cleaner options for converting natural gas into electricity, but as yet it is not price-competitive.

Natural gas is supplied to homes, where it is used for such purposes as cooking in natural gas-powered ranges and/or ovens, natural gas-heated clothes dryers, heating/cooling and central heating. Home or other building heating may include boilers, furnaces, and water heaters. CNG is used in rural homes without connections to piped-in public utility services, or with portable grills. However, due to CNG being less economical than LPG, LPG (Propane) is the dominant source of rural gas.

Compressed natural gas (methane) is a cleaner alternative to other automobile fuels such as gasoline (petrol) and diesel. As of 2005, the countries with the largest number of natural gas vehicles were Argentina, Brazil, Pakistan, Italy, Iran, and the United States. The energy efficiency is generally equal to that of gasoline engines, but lower compared with modern diesel engines. Gasoline/petrol vehicles converted to run on natural gas suffer because of the low compression ratio of their engines, resulting in a cropping of delivered power while running on natural gas (10%-15%). CNG-specific engines, however, use a higher compression ratio due to this fuel's higher octane number of 120-130.

Russian aircrafts manufacturer Tupolev is currently running a development program to produce LNG- and hydrogen-powered aircraft. The program has been running since the mid-1970s, and seeks to develop LNG and hydrogen variants of the Tu-204 and Tu-334 passenger aircraft, and also the Tu-330 cargo aircraft. It claims that at current market prices, an LNG-powered aircraft would cost 5,000 roubles (~ \$218/ £112) less to operate per ton, roughly equivalent to 60%, with considerable reduction of carbon monoxide, hydrocarbon and nitrogen oxide emissions.

The advantages of liquid methane as a jet engine fuel are that it has more specific energy than the standard kerosene mixes and that its low temperature can help cool the air which the engine compresses for greater volumetric efficiency, in effect replacing an intercooler. Alternatively, it can be used to lower the temperature of the exhaust.

Natural gas can be used to produce hydrogen, with one common method being the hydrogen reformer. Hydrogen has various applications: it is a primary feedstock for the chemical industry, a hydrogenating agent, an important commodity for oil refineries, and a fuel source in hydrogen vehicles. Natural gas is also used in the manufacture of fabrics, glass, steel, plastics, paint, and other products.

It is difficult to evaluate the cost of heating a home with natural gas compared to that of heating oil, because of differences of energy conversion efficiency, and the widely fluctuating price of crude oil. However, for illustration, one can calculate a representative cost per BTU. Assuming the following current values (2008):

For natural gas.

- One cubic foot of natural gas produces about 1,030 BTU (38.4 MJ/m<sup>3</sup>).
- The price of natural gas is \$9.00 per thousand cubic feet (\$0.32/m<sup>3</sup>).

For heating oil.

- One US gallon of heating oil produces about 138,500 BTU (38.6 MJ/l).
- The price of heating oil is \$2.50 per US gallon (\$0.66/l) .

This gives a cost of \$8.70 per million BTU (\$8.30/GJ) for natural gas, as compared to \$18 per million BTU (\$17/GJ) for fuel oil. Of course, such comparisons fluctuate with time and vary from place to place dependent on the cost of the raw materials and local taxation.

### *Current pipelines.*

**Natural gas pipelines.** The long-distance transportation of natural gas became practical in the

late 1920s with improvements in pipeline technology. From 1927 to 1931 more than ten major gas pipeline systems were built in the United States. Gas pipelines in Canada connect gas fields in western provinces to major eastern cities. One of the longest gas pipelines in the world is the Northern Lights pipeline, which is 3,400 miles (5,470 kilometers) long and links the West Siberian gas fields on the Arctic Circle with locations in Eastern Europe.

**Oil and petroleum products pipelines.** Pipelines are used extensively in petroleum handling. In the field, pipes called gathering lines carry the crude oil from the wells to large storage depots located near the oil field. From these depots the oil enters long-distance trunk lines, which may carry it to an intermediate storage point or directly to refineries.

By the last quarter of the 20th century, there were about 250,000 miles (400,000 kilometers) of oil pipeline in operation in the United States. About one third of the total mileage consisted of crude-oil trunk lines. Pipelines carry large volumes of crude oil from fields in Texas, Louisiana, and Oklahoma to refineries in the Midwest and on the East coast of the United States. The 800-mile (1,300-kilometer) north-south trans-Alaskan oil pipeline, which began operation in 1977, connects the Prudhoe Bay fields on the northern coast of Alaska to Valdez on Prince William Sound. Europe also has several crude-oil pipelines supplying inland refineries. In the Middle East large pipelines carry crude oil from oil fields in Iraq, Saudi Arabia, and other oil-exporting countries to deepwater terminals on the Mediterranean Sea.

From the refinery, large volumes of petroleum products travel to the market area by way of product lines. In areas of high consumption, several similar products gasoline, furnace oil, and diesel oil, for example may be shipped in the same line in successive batches of several tens or hundreds of thousands of barrels each. The first European product line, called the TRAPIL line, was completed in 1953 in France. In 1964 the world's largest products line began operation in the United States; the pipeline can transport 1 million barrels of products per day from Houston, Tex., to New Jersey.<sup>1</sup>

**The trans-Alaskan pipeline** was the most expensive pipeline in the world costing 9 billion dollars to build. It is 48 inches (122 centimeters) in diameter and 800 miles (1,300 kilometers) long. Oil moves southward through it, at a rate of 1.5 million barrels each day, from the giant Prudhoe Bay oil field on the northern coast of Alaska to the ice-free port of Valdez, where the oil is shipped by tankers to refineries on the West coast of the United States. The pipeline traverses three mountain ranges and 250 rivers and streams. For some 400 miles (640 kilometers) it is suspended on pylons above permanently frozen ground called permafrost. If the pipeline had been buried in the ground, the heat from the oil in the pipeline would have melted the permafrost, causing considerable environmental damage.

This is a list of countries by total length of pipelines mostly based on [The World Fact book](#) accessed in June 2008 .

Rank	Country	Total length of pipelines (km)	Structure	Date of Information
1	United States	793,285	petroleum products 244,620 km; natural gas 548,665 km	2006
2	Russia	244,826	condensate 122 km; gas 158,699 km; oil 72,347 km; refined products 13,658 km	2007
3	Canada	98,544	crude and refined oil 23,564 km; liquid petroleum	2006

<sup>1</sup> Reference: Compton's Interactive Encyclopedia.

4 China

gas 74,980 km  
 49,690 gas 26,344 km; oil 17,240 km; refined products  
 6,106 km

2007



Building typical ground pipeline.  
 Requires ground right of way and results in damage to ecology



Trans-Alaska oil pipeline.  
 Notice the damage.

***Some currently planned pipeline projects:***

The **Nabucco pipeline** is a planned natural gas pipeline that will transport natural gas from Turkey to Austria, via Bulgaria, Romania, and Hungary. It will run from Erzurum in Turkey to Baumgarten an der March, a major natural gas hub in Austria. This pipeline is a diversion from the current methods of importing natural gas solely from Russia which exposes EC to dependence and insecurity of the Kremlin practices. The project is backed by the European Union and the United States.



The pipeline will run from Erzurum in Turkey to Baumgarten an der March in Austria with total length of 3,300 kilometers (2,050 mi). It will be connected near Erzurum with the Tabriz-Erzurum pipeline, and with the South Caucasus Pipeline, connecting Nabucco Pipeline with the planned Trans-Caspian Gas Pipeline. Polish gas company PGNiG is studying the possibility of building a link to Poland with the Nabucco gas pipeline.

In the first years after completion the deliveries are expected to be between 4.5 and 13 billion cubic meters (bcm) per annum, of which 2 to 8 bcm goes to Baumgarten. Later, approximately half of the capacity is expected to be delivered to Baumgarten and half of the natural gas is to serve the markets en-route. The transmission volume of around 2020 is expected to reach 31 bcm per annum, of which up to 16 bcm goes to Baumgarten. The diameter of the pipeline would be 56 inches (1,420 mm).

The project is developed by the Nabucco Gas Pipeline International GmbH. The managing director of the company is Reinhardt Mitschek. The shareholders of the company are: OMV (Austria), MOL (Hungary), Transgaz (Romania), Bulgargaz, (Bulgaria), BOTAS (Turkey), RWE (Germany).

In 2006, Gazprom proposed an alternative project competing Nabucco Pipeline by constructing a second section of the Blue Stream pipeline beneath the Black Sea to Turkey, and extending this up through Bulgaria, Serbia and Croatia to western Hungary. In 2007, the South Stream project through Bulgaria, Serbia and Hungary to Austria was proposed. It is seen as a rival to the Nabucco pipeline. Ukraine proposed White Stream, connecting Georgia to Ukrainian gas transport network.<sup>2</sup>

These mega-pipeline projects and others currently planned will require investment of at least \$200 Billion in the next few years. We propose a much cheaper alternative, an aerial pipeline that is lifted because natural gas is lighter than air and as such a lifting gas. An inflatable pipeline pressurized with natural gas will levitate and float up as if full of helium. Each end of the pipeline will be tethered to the ground but the middle will soar above land and sea at altitudes between .1 and 6 kilometers. It can span seas and can be up to a hundred times cheaper than conventional undersea pipelines. It can be only 100 meters above the ground and easily monitored and repaired.

The main differences of the suggested Gas Transportation Method and Installation from current pipelines are:

1. The tubes are made from a lightweight flexible thin film (no steel or solid rigid hard material).
2. The gas pressure into the film tube equals an atmospheric pressure or less more (<1.5 atm.) (The current gas pipelines have pressure up 220 atmospheres.).
3. The great majority of the pipeline [except compressor (pumping) and driver stations] is located in atmosphere at a high altitude (0.1-6 km) and does not have a rigid compression support (pillar, pylon, tower, bearer, etc.) though it may be tethered. The current pipelines are located on the ground, under ground or under water.
4. The transported gas contained within the pipeline supports the gas pipeline at high altitude.
5. Wing devices may make additional lift.
6. The gas pipeline can be used as an air transport system for oil and solid payloads with a high speed for each container shipped up of 250 m/sec.
7. The gas pipeline can be used as for a large scale transfer of mechanical energy.

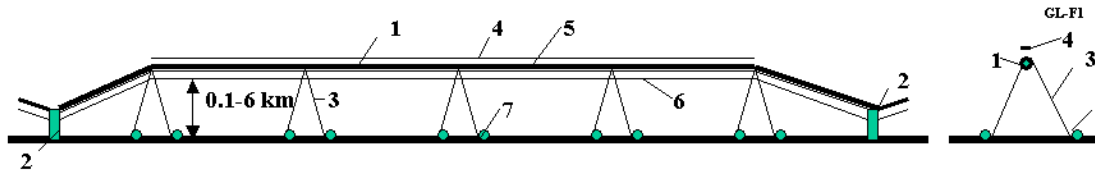
<sup>2</sup> [http://en.wikipedia.org/wiki/Category:Future\\_pipelines](http://en.wikipedia.org/wiki/Category:Future_pipelines).

The suggested Method and Installation have huge advantages in comparison with modern steel gas pipelines.

### Description of innovation

A gas and payload delivering gas/load pipeline is shown on figs. 1 - 6.

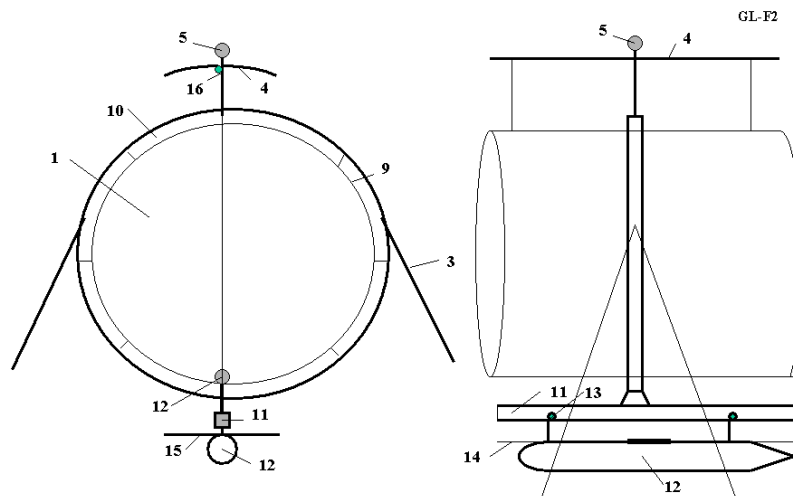
Fig.1 shows the floating pipeline.



**Fig.1.** General view of air pipeline between two compression (pump) stations. (a, left) Side view, (b-right) front view. Notations: 1 - pipeline in atmosphere, 2 - compression station, 3 - tensile stress element, 4 - support wing device, 5 – aircraft warning light, 6 - load (container) monorail, 7 - winch.

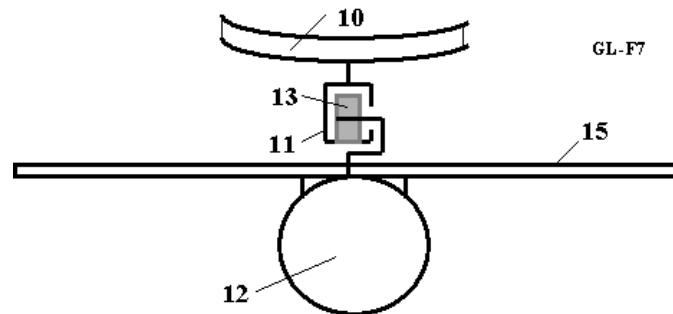
The installation works as follows: The compressor station pumps in gas from the system input (natural gas processing plant, storage system, etc) into the floating pipeline. The tube is made from light strong flexible gas-impermeable fire-resistant material (film), for example, from composite material (fibers, whiskers, nanotubes, etc.). The internal gas pressure is a bit higher than the outside atmospheric pressure (up 0.1- 0.2 atm) both to keep the tube inflated and to send the contents flowing toward the far end of the pipeline. Natural gas has methane as a main component with a specific density about  $0.72 \text{ kg/m}^3$ . Air, by contrast, has a specific density about  $1.225 \text{ kg/cubic meters}$ . It means that every cubic meter of gas (methane) or a gas mixture with similar density has a lift force approximating 0.5 kg. Each linear (one meter) weight of the tube is less than the linear lift force of the gas in the tube and the pipeline thus has a net lift force. The pipeline rises up and is held at a given altitude (0.1 - 6 km) by the tensile elements 3. The altitude can be changed by the winches 7. The compressor station is located on the ground and moves the flowing gas to the next compressor station which is usually located at the distance 70 - 250 km from previous. Inside of the pipeline there are valves (fig.4) dedicated to lock the tube in case of extreme damage. The pipeline has also the warning light 5 for aircraft.

Fig.2 shows the cross-section of the gas pipeline and support ring. The light rigid tube support ring helps intermediate the motions and stresses of, variously, the lift force from the gas tube, wing support devices, from monorail and load containers, and the tension elements (tiedown tethers) 5.



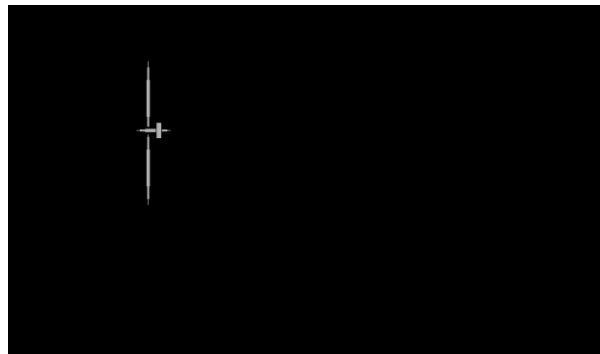


**Fig.2.** Cross-section and support ring of aerial pipeline. (*a-left*) front view, (*b-right*) side view. Notations: 9 - double casing, 10 -rigid ring, 11 - monorail, 12 - wing load container, 13 - rollers of a load container, 14 - thrust cable of container, 15 - container wing. Other notations are same as in fig.1.



**Fig, 2a.** Front view of the wing load container, monorail, and suspension bracket. Other notations are same as figs.1-2.

Fig.3 shows the compressor (pumping) station. The station is located on the ground or water and works in the following way. The engine 32 rotates compressor 31. This may be in the form of propellers located inside a rigid ring body connected to the flexible tubes of installation 1. The pipeline tubes are located floating in atmosphere near the compressor. The propeller moves the gas in the given direction.



**Fig.3.** Compression (pumping) station. Notations: 31 - compressor (propeller), 32 - engine. Other notations are same as figs.1-3.

Fig.4 shows two variants of a gas valve. The first valve version is an inflatable ball. The ball would expand out and close the gas path. The second version is a conventional light flat valve-closing disc in a circular form.

The valve works in the following way. When the tube section is damaged, the pressure decreases in a given section. The control devices measure it, the valves close the pipeline. The valve control devices have a connection with a central dispatcher, who can close or open any section of the pipeline.

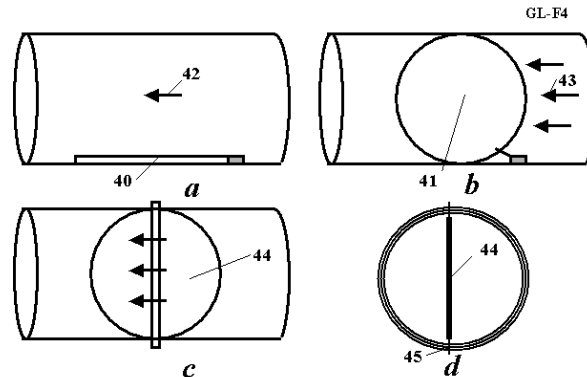
Fig.4a shows the spherical valve (a ball) in packed (closed) form. Fig.4b shows the spherical valve (a ball) in an open form.

The tubes of pipeline have a double wall (films) and gas sealing liquid may be between them. If the walls damage the streak gas flows out and the second film closes the hole in the first film and conserves the pipeline's gas.

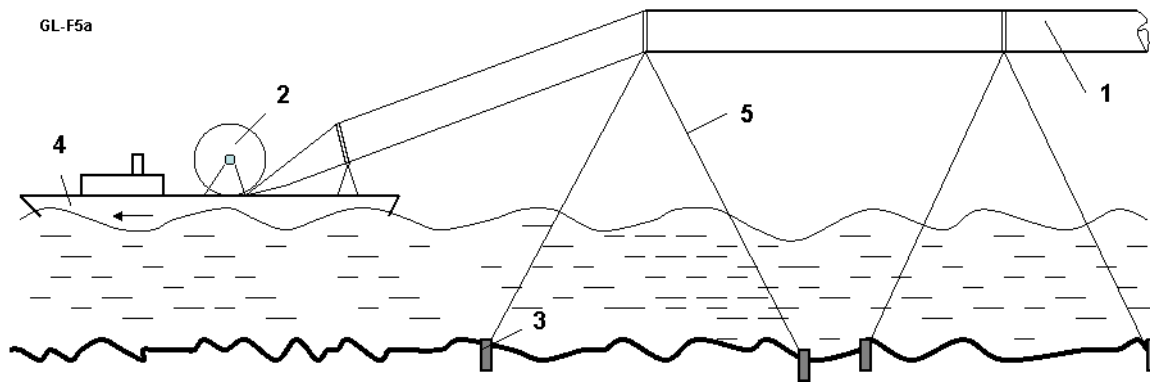
The wing device 4 is a special automatic wing. When there is a wind whether and the side wind produce a strong side force, the wing devices produce a strong lift force and supports the pipeline in a vertical position.

The wind device works in the following way. When there is a side wind the tube has the wind drag and the wind device creates the additional lift force. All forces (lifts, drags, weights) are maintained toward equilibrium. The distance between the tensile elements is such that the tube can withstand the maximum storm wind speed. The system can have a compensation ring. The compensation ring includes ring, elastic element, and cover. The ring compensates the temperature's change of the tube and decreases stress from wind.

Figure 5 shows the building of offered gas pipeline. The ship uncoils the roll of the inflatable film tube and an end ground station fills it a gas. The gas lifts the tube at need altitude and ship team fixes (anchors) a tube position. Other method: delivery the filled gas tube by helicopter(fig.5a).



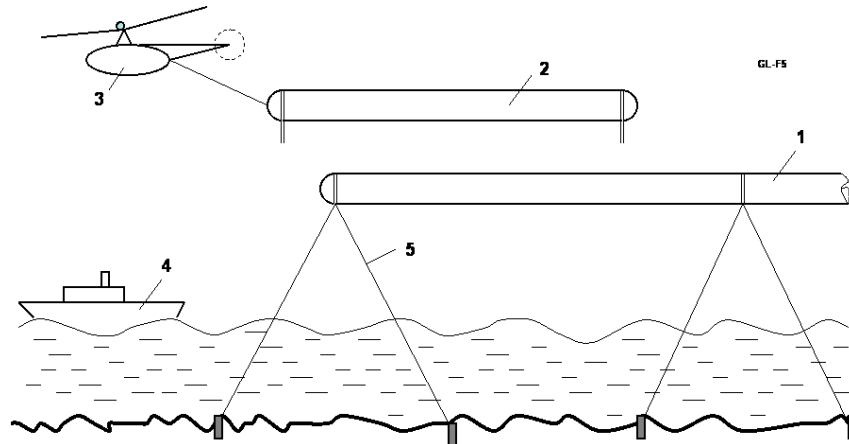
**Fig. 4.** Gas valve. (a)-(b) Inflatable valve, (c)-(d) Flat valve. Notations: 40 - inflatable valve in compact position, 41 - inflatable valve in fill out position, 42 - gas flow, 43 - gas pressure, 44 - flat choker disc.



**Fig. 5.** Building the offered gas pipeline by sea ship. *Notation*; (1): Gas pipeline; (2): Roll from the inflatable film tube; (3): Load for fixing tube to sea bottom; (4): Support ship; (5): Tensile links.

The suggested gas pipeline has advantages over the conventional steel gas pipeline:

1. The suggested gas pipeline is made from a thin film which is hundreds times less expensive than a current ground or sea bottom gas pipeline made from steel tubes.
2. The construction time may be decreased from years to months.
3. There is no need to supercompress a gas (over 200 atmospheres) and spend huge energy for that.
4. No large area of expensive user rights needed on ground surface and little surface environmental damage during the building and use of the pipeline.
5. No surface environmental damage in case of pipeline damage during use of the pipeline.
6. Easy to repair.



**Fig.5a.** Building the offered gas pipeline by helicopter. Notation: 1 – gas pipeline; 2 – delivered section of gas pipeline; 3 – deliver helicopter; 4 – support ship; 5 – tensile links.

7. Less energy used in gas transit and delivery.
8. Additional possibility of payload delivery in both directions.
9. If the pipeline is located at high altitude, it is more difficult for terrorist diversion and for petty or large scale gas stealing by third parties when the suggested pipeline cross the third country (for example, unknown parties in the Ukraine typically are said to steal 10-15% amount of the gas from Russian pipelines transiting the Ukraine.).
10. The suggested transportation system may be also used for a transfer of mechanical energy from one driver station to another, more cheaply than electric power could be sent.

More detailed description of the innovation may be found in references [1]-[8]. Below, projects suitable for many regions are proposed. This paper is by no means exhaustive and apparent problems in this project, such as standing up to strong winds, have been solved and the author is prepared to discuss the problems and solutions with serious organizations, which are interested in researching and developing these ideas and related projects.

### Methods of the estimation of the altitude gas pipeline

1. Gas **delivery capability** is

$$G = \pi D^2 V / 4 \text{ [m}^3/\text{sec]}, \quad M = \rho G \text{ [kg/s]}, \quad (1)$$

where:  $D$  is diameter of tube [m];  $V$  is average gas speed [m/sec],  $M$  is mass flow [kg/s],  $\rho = 0.74 \text{ kg/m}^3$  is gas methane density. Result of computation is presented in Fig. 6.

2. Increment **pressure** [N/m<sup>2</sup>] is

$$P = \lambda L \rho V^2 / 2D, \quad (2)$$

where:  $\lambda$  is dimensionless factor depending on the wall roughness, the fluid properties, on the velocity, and pipe diameter ( $\lambda = 0.01 - 0.06$ );  $L$  is the distance between pump station [m];  $\rho$  is fluid density [kg/m<sup>3</sup>].

The dimensionless factor can be taken from graph [5, p.624]. It is

$$\lambda = f(R, \varepsilon), \quad (3)$$

where:  $R = VD\rho/\mu$  is Reynolds number,  $\mu$  is fluid viscosity;  $\varepsilon$  is measure of the absolute roughness of tube wall. In our case  $\lambda = 0.015$ .

Result of computation of the gas pressure in relation to the distance between pump station and gas speed are presented in Fig. 7.

3. **Lift force**  $F$  of each one meter length of pipeline is

$$F = (v_a - v_m)v \quad , \quad (4)$$

where:  $v_a = 1.225 \text{ kg/m}^3$  is air density for standard atmosphere;  $v_m = 0.72 \text{ kg/m}^3$  is methane density;  $v = \pi D^2/4$  is volume of one meter length of pipeline,  $F$  [kg/m]. Results of computation are presented in Fig.8.

4. Needed **thickness**  $\delta$  of tube wall is

$$\delta = PD/2\sigma \quad , \quad (5)$$

where:  $P$  is pressure [see Eq.(2)];  $\sigma$  is safety stress. That is equal to 50 - 200  $\text{kg/mm}^2$  for materials made from current artificial fibers. (Stronger materials, of course, would allow better results) Results of computation are presented in Fig.9.

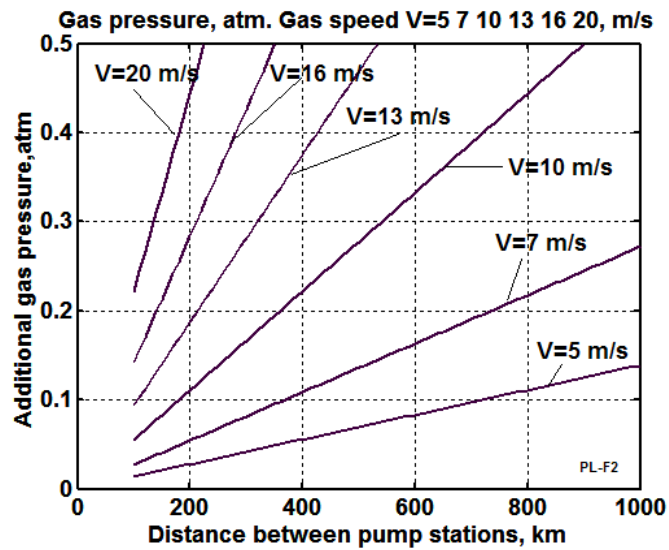


Fig. 6. Delivery capacity of gas by the offered floating gas pipeline by gas speed and tube diameter.

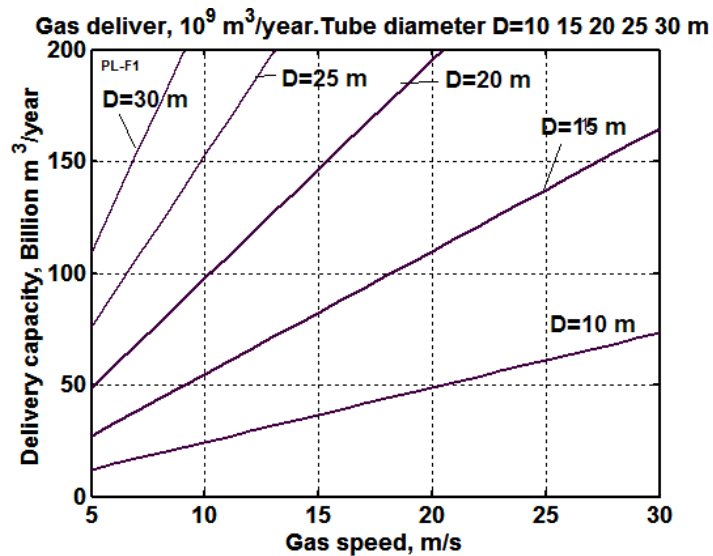


Fig.7. Gas pressure versus the distance between pump stations for different gas speeds.

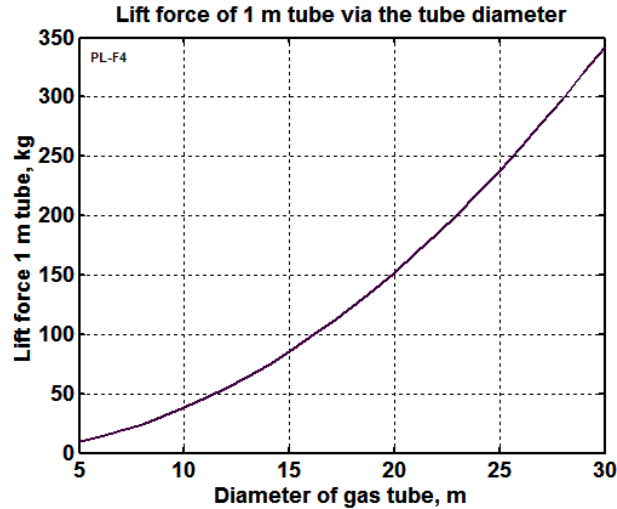


Fig.8. Lift force of each 1 meter of methane gas bearing tube in relation to tube diameter.

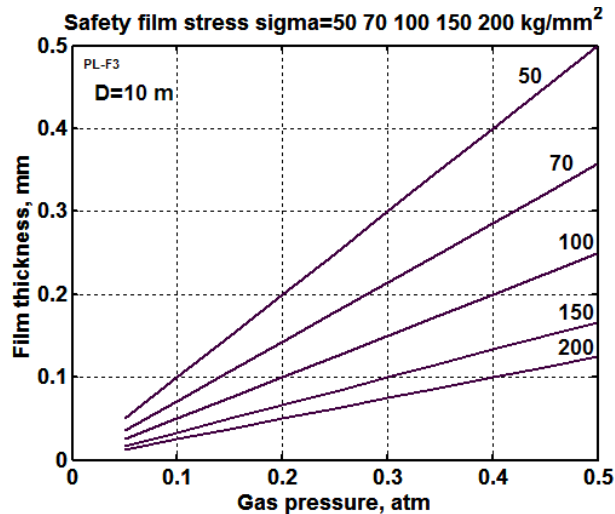


Fig. 9. Film thickness via gas pressure and the safety film stress for the tube diameter  $D = 10$  m.

5. **Weight** of one meter of pipeline is

$$W = \pi D \delta \gamma , \quad (6)$$

where:  $\gamma$  is specific weight of matter tube material (film, cover). That equals about  $\gamma = 900 - 2200 \text{ kg/m}^3$  for matter from artificial fiber.

6. **Air drag**  $D$  of pipeline from side wind is

$$D = C_d \rho V^2 S / 2 , \quad (7)$$

where:  $C_d = 0.01 \sim 0.2$  is drag coefficient;  $S$  is logistical pipeline area between tensile elements;  $\rho = 1.225 \text{ kg/m}^3$  is air density.

7. Needed **pumping power** is

$$N = PG / \eta , \quad (8)$$

where:  $\eta \approx 0.9$  is the efficiency coefficient of a compressor station. Result of computation is presented in Fig.10.

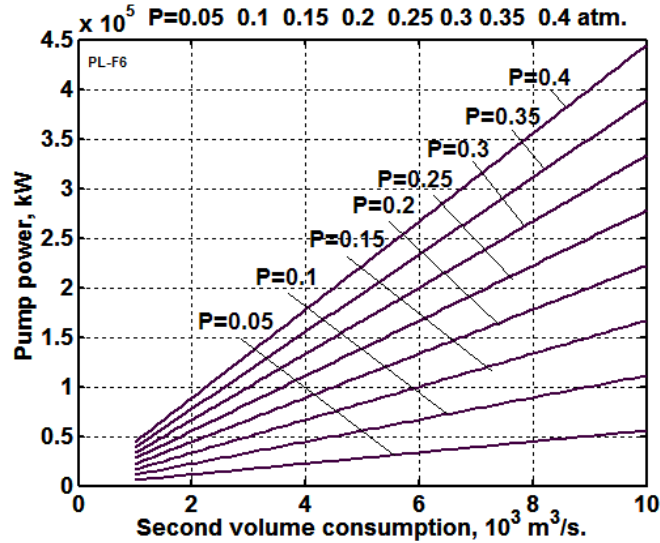


Fig.10. Pumping power versus the volume consumption and gas pressure.

We may also view that pumping power equals

$$N = 2C_f M V^2 L / D \eta, \quad (8a)$$

where  $M$  is mass of the gas [kg/s],  $L$  is length of pipeline between compression station [m],  $C_f$  is the friction coefficient. That means the delivery power decreases when we use the tubes of bigger diameter. In our case the chosen diameter is 10-20 m. That means the pumping power (to force the gas through the pipeline) will be about 10 times less than in a conventional high pressure pipeline having maximal diameter of 1.44 meters. The conventional steel pipeline method requests also a lot of additional pumping energy for gas compression of up to 70 – 200 atmospheres.

#### Load container transportation system mounted under pipeline.

1. **Load delivery** capability by wingless container is

$$G_p = k F V_p, \quad (9)$$

where:  $k$  is load coefficient ( $k \approx 0.5 < 1$ );  $V_p$  is speed of container (load). Result of computation is presented in Fig.11.

2. **Friction force** of wingless containers (using wheels or rollers on a monorail) is

$$F_c = f W_c, \quad (10)$$

where:  $f \approx 0.03 - 0.05$  is coefficient of roller friction;  $W_c$  is weight of containers between driver stations.

3. **Air drag of a container** is

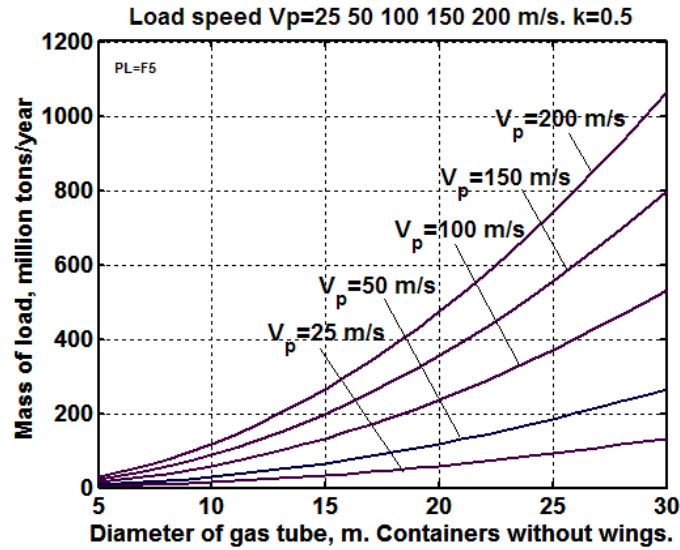
$$D_c = C_c \rho V^2 S_c / 2, \quad (11)$$

where:  $C_c$  is drag friction coefficient related to  $S_c$ ;  $S_c$  is the cross-sectional area of container.

4. The **lift force** of a winged container is

$$L_c = C_L q S_{cw} = C_L \frac{\rho_a V^2}{2} S_{cw}, \quad (12)$$

where:  $C_L \approx 1 - 1.5$  is coefficient of lift force;  $q = \rho_a V^2 / 2$  is air dynamic pressure,  $N/m^2$ ;  $S_{cw}$  is wing area of winged container,  $m^2$ .



**Fig.11.** Load delivery via the tube diameter and speed payload by wingless containers for  $k=0.5$ . Delivery by winged container may be some times more. The load delivery of a conventional two-line railroad is about only 15-30 million tons/year. But a railroad's capital cost is more expensive by many times than the offered high-speed aerial transport system. The big (diameter 1.4 m) oil pipeline has delivery capability of about 100 million tons/year.

5. The **drag of a winged container** may be computed by equation

$$D_C = C_L q S_{cw} / K = C_L \frac{\rho_a V^2}{2K} S_{cw}, \quad \text{where } K = \frac{C_L}{C_D}, \quad (13)$$

where  $K \approx 10 - 20$  is the coefficient of aerodynamic efficiency;  $C_D$  is air drag coefficient of winged container. If lift force of wing container equals the container weight, the friction force  $F$  is absent and in theory it does not require a solid monorail.

6. The **delivery (load) capacity** of the winged container system as a whole is

$$G_c = \frac{W_1 V_c T}{d}, \quad (14)$$

where  $W_1$  is weight of one container, kg;  $V_c = 30 - 200$  m/s is container speed, m/s;  $T$  is time, s;  $d$  is distance between two containers, in meters.

7. The **lift and drag** of the wing device may be computed by Equations (12)-(13). The power needs for transportation system of winged containers is found by

$$P_c = \frac{g W V_c}{K_c}, \quad (15)$$

where  $W$  is total weight of containers, kg;  $g = 9.81$  m/s<sup>2</sup> is Earth gravity;  $K_c \approx 10 - 20$  is aerodynamic efficiency coefficient of container and thrust cable;

8. The **stability** of the pipeline against a side storm wind may be estimated by the inequality

$$A = \frac{L_T + L_d - g W_T - g W_s}{D_T + L_d / K_d} > \tan \alpha > 0, \quad (16)$$

where  $L_T$  is lift force of given part of pipe line, N;  $L_d$  is lift force of wing device, N;  $W_T$  is a weight of pipeline of given part, kg;  $W_s$  is weight of the given part suspending system (containers, monorail, thrust cable, tensile element, rigid ring, etc.), kg;  $D_T$  is drag of the given part of pipeline, N;  $L_d$  is the lift force of the wing device, N;  $K_d$  is an aerodynamic efficiency coefficient of wing device;  $\alpha$  is the angle between tensile element and ground surface.



## Mega-Project

(Tube diameter equals  $D = 10$  m, gas pipeline has the suspended- load transport system, the project is suitable for many regions)

Let us take the tube diameter  $D = 10$  m, the distance between the compressor-driver stations  $L = 100 - 1000$  km and a gas speed  $V = 10$  m/sec.

Gas delivery capacity is then (Eq. (1))

$$G = \pi D^2 V / 4 = 800 \text{ m}^3/\text{s} = 25 \text{ billions m}^3 \text{ per year } [\text{km}^3/\text{year}].$$

For the Reynolds number  $R = 10^7$  value  $\lambda$  is 0.015,  $P = 5 \times 10^3 \text{ N/m}^2 = 0.05 \text{ atm}$  (Eq. (2)-(3) for  $L = 100$  km). We can take  $V = 20$  m/s and decrease delivery capacity in two (or more) times.

Lift force (Eq. 4) of one meter pipeline's length equals  $F = 39$  kg for diameter  $D = 10$  m.. For  $\sigma = 200$  kg/sq.mm the tube wall thickness equals  $\delta = 0.0125$  mm (Eq. 5 for  $P = 0.05$  ). We take the thickness of wall as  $\delta = 0.15$  mm. That is enough **for a distance of 1200 km between pumping stations!**

The cover weight of each one meter of the pipeline's length is 7 kg [Eq. (6)]. The needed power of the compressor station (located at distance of 1000 km) equals  $N = 44,400$  kW for  $\eta = 0.9$  [Eq.(8)].

### Cost of altitude gas pipeline

Let us take the film thickness  $\delta = 0.15$  mm, specific weight of film  $\gamma = 1440$  kg/m<sup>3</sup>, film cost  $c = \$4/\text{kg}$ , diameter of tube  $D = 10$  m. Then volume of 1 m of tube is  $v = \pi D \delta = 4.7 \times 10^{-3} \text{ m}^3$ , weight is  $W = \gamma v = 6.77$  kg/m, cost of 1 m tube film is  $C_1 = cW = \$28/\text{m}$ .

The tube needs one wing attached to the tube for each length 10 m. Let us take the cost of one such wing \$20. It is  $C_2 = \$2/\text{m}$ . Support cables and anchors for each tube length of 100 m cost about \$200 or  $C_3 = \$2/\text{m}$ . Let us take the cost of pumping station good for 100 km is \$100,000 and good for 1000 km the \$1 mln. That means the cost of the pumping station is  $C_4 = \$1/\text{m}$ .

The total cost of 1 m of pipeline (material) is  $C = C_1 + C_2 + C_3 + C_4 = \$33/\text{m}$  or  $C = 33\text{K}/\text{km}$  (K is thousand). The Labor and additional works usually costs 100-200% from material. That means each 1 km of the offered altitude pipeline may cost as little as \$100K/km after the tooling and other overhead costs are paid for.

In conventional pipelines the steel tubes alone cost 0.3 – 1 million dollars per km. The builder must also pay a lot of money for the right of way on the Earth's surface. The deliver must also annually pay fees for gas transition through the territory of other countries - transition rights. The offered pipelines are very cheap and in many cases may be located over the high seas, cutting down greatly on the right of way fees.

Compare the cost of the current and proposed ground and sea pipelines in Table 1. As you see the offered pipe is ~ 10 – 100 times cheaper than conventional ground pipelines of same length. They may be built if need be more rapidly; in a year or so, with extra money to cover the expense of such rapid construction, in as little as 5-6 months, to be contrasted with 4-5 years as conventional pipelines. This time value of capital saved is a major advantage.

Such a pipeline does not require payment for transition across other countries via ground rights (air rights are usually far cheaper because the uses of the land may continue below) and they require 10 - 15 times less energy for pumping gas because there is no great compression and less gas friction.

**Table 1.** Design and current pipelines.

#	Pipeline	Length, km	Sea part, km	Cost 1 line, \$Billion	Cost 1 km, \$mln/km	Min. diameter, m	Deliver capacity, km <sup>3</sup> /year	Final year of building
1	Russia-Germany	1200	1200	5	4.2	1.44	27.5	2010
2	Russia-Bulgaria	900	900	10	11	?	30	2013
3	Asia-Europa	3300	-	10	3	1.42	4.5-28	2013
4	Russia-Turkey	1230	396	3.2	2.64	0.61	16	1997
5	Albania-Italy	520	-	1.9	3.65	?	10	2011
6	Turkey-Greece	296	17	?	-	0.914	7	2007
7	Greece-Italy	800	200	1.6	2	?	8	2012
8	Proposed Levitated gas line	1000	1000	0.1	0.1	10	25	-

Source of 1-7: Wikipedia.

### Load transportation System

Let us take the speed of delivery as equal to  $V = 30$  m/sec, payload capability as 20 - 25 kg per one meter of pipeline in one direction. Then the delivery capability for non-wing containers is 70 kg/s or 20 million tons per year.

That is more than the gas delivery capability (18 million tons per year)! The total load weight suspended under the pipeline of length  $L = 100$  km equals 2500 tons. If a friction coefficient is  $f = 0.03$ , the needed thrust is 75 tons and needed power from only friction roller drag is  $N_1 = 22,500$  kW (Eq. (10)).

If the air drag coefficient  $C_d = 0.1$ , cross section container area  $S_c = 0.2$  m<sup>2</sup>, the air drag of each single container equals  $D_{c1} = 2.2$  kg, and total drag of 20,000 containers over a length of 100 km is  $D_c = 44$  tons. The need driver power is  $N_2 = 13,200$  kW. The total power of transportation system is  $N = 22500 + 13200 = 35,700$  kW. The total thrust force is  $77 + 44 = 121$  tons.

If  $\sigma = 200$  kg/sq.mm, the cable diameter equals 30 mm.

The suggested delivery system can delivery a weight units (non-wing container) up to 100 kg if a length of container is 5 - 7.5 m.

The pipeline and container delivery capability may be increased by **tens of times** if we will use the wing containers. In this case we are not limited by load levitation capability. The wing container needs just a very light monorail (if any, for guidance rather than support) and a closed-loop thrust cable for drive. That can be used for delivery of water, oil or payload in containers. For example, if our

system delivers  $4 \text{ m}^3/\text{s}$ , that is equivalent of the conventional river (or a water irrigation canal) having a cross-section area of  $20 \times 2 \text{ m}$  and water speed  $0.1 \text{ m/s}$ .

If we will use this system for transfer of mechanical energy, we can transfer  $35,700 \text{ kW}$  for the cable speed at  $30 \text{ m/sec}$ , and 8 times more by the same cable having a speed of  $250 \text{ m/sec}$ . Such a conventional power line over  $1000 \text{ km}$  distances would be more expensive than this entire system.

If the  $\alpha < 60^\circ$  and wing of tube wing device has width of  $6 \text{ m}$ , our system is stable against a side storm wind  $30 - 40 \text{ m/s}$ .

The reader can compare the offered installation with known pipelines in Table1 or described in [8]-[17].

**Cost of the load system.** Let us take the cost  $\$100$  of 1 container  $0.5 \times 0.5 \times 5 \text{ m}$  ( $C_1 = \$20/\text{m}$ , the cost of the thrust-providing electric motor as  $\$20,000/100\text{km}$  ( $C_2 = \$0.2/\text{m}$ ), the cost of suspending system  $C_3 = \$2/\text{m}$  (light monorail). Then the total cost of material for transport system will be about  $\$22.2/\text{m}$  or  $\$22.2\text{K}/\text{km}$ .

The cost of  $1 \text{ km}$  of 1 line railway is about  $\$(1-2) \text{ Million}/\text{km}$ , (without engines and tank cars). That means the railway is  $\sim 400$  times more expensive than the offered air load transport system.

**Note about the proposed Dead Sea air water system.** We can use the offered system for delivery of water from the Red or Mediterranean Seas to the Dead Sea. If we will use the wing containers we can deliver up  $100$  million cubic meters water per year if the diameter of the gas tube is  $10 \text{ m}$ . That is enough to stop the decline of the Dead Sea if  $90\%$  of the Dead Sea surface (except along the coasts where tourists go) is covered by plastic surface film to stop evaporation, not counting on any influx of water from the Jordan River. The preferred option will probably be a gas tube diameter of  $30 \text{ m}$  (Delivery capacity is  $900 \text{ M}/\text{cubic meters}$ ) and omitting covering the Dead Sea surface for aesthetic reasons. The cost of this proposed  $30\text{-meter}$  diameter delivery system, if the first one built, will be about  $200\text{-}700$  million dollars (or up to  $25$  times cheaper than the well-known conventional project Red-Dead Sea (canal) ( $\$5 \text{ billion USD.}$ )). Eventually the cost of a second such pipeline could be half this, and the Dead Sea could in principle be raised to any desired level.

## References

1. A.A. Bolonkin, Patent Application "Method for Gas and Payload Transportation at Long Distance and Installations for It", Application to USPTO # 09/978,507 of 10/18/2001.
2. A.A. Bolonkin, Patent Application "Method Transportation of Vehicles and Installations for It", Application to USPTO # 09/893,060 of 6/28/2001, patent US #6,494,143 B1.
3. A.A. Bolonkin, Air Cable Transport System, Journal of Aircraft, Vol. 30, No.2, March-April 2003, pp. 265-259.
4. A.A. Bolonkin and R.B. Cathcart, A Low-Cost Natural Gas/Freshwater Aerial Pipeline. <http://arxiv.org> search "Bolonkin".
5. A.A. Bolonkin, Non-Rocket Space Launch and Flight, Elsevier, London, 2006, 488 pgs.
6. A.A. Bolonkin, New Concepts, Ideas, and Innovations in Aerospace, Technology and Human Sciences, NOVA, 2008, 480 pgs.
7. A.A. Bolonkin, Macro-Projects: Technology and Environment. NOVA, 470 pgs., 2009.
8. A. A. Bolonkin, at el., Dead Sea. At print, 2008.
9. K.K.Kienow (ed), *Pipeline Design and Installation*, 1990.
10. Compton's Interactive Encyclopedia.
11. M.L.Navvar (ed), *The Piping Handbook*, 6<sup>th</sup> ed.,1992.
12. P.Tullis, *Hydraulics of Pipelines*, 1989.
13. Designed oil and gas fields, main pipelines, refineries, and gas processing plants, Alberta, Canada, 1976, Map.Div..

14. Main line natural gas sales to industrial users (microform). US Dep. of Energy Readex Microfiche E 3.11/14 7V 1979.
15. C.W. Byrer and R.D. Malone, Proceedings of the Natural Gas Conference: Emerging technologies for the Natural Gas Industry, Houston, Texas, U.S. Department of Energy, Federal Energy Technology Center< March 1997. (Full text available on the web at:  
[http://www.netl.doe.gov/publications/proceedings/97/97ng/ng97\\_toc.html](http://www.netl.doe.gov/publications/proceedings/97/97ng/ng97_toc.html)
16. Oil and Gas R&D Programs: Securing the U.S. energy, environmental, and economic future, U.S. Department of Energy, Office of Energy, Office of Natural Gas and Petroleum Technology, March 1997.
17. *Wikipedia*. Some background material in this article is gathered from Wikipedia under the Creative Commons license. . <http://wikipedia.org> .



## Chapter 2B

# Production Fresh Water by Exhaust Gas of Electric and Heat Plants

### Abstract

A new, cheap method for the extraction of freshwater from the sea which is fundamentally distinct from all existing methods that extract freshwater from the sea water is proposed. This method uses the hot exhaust gas (smog) of industry (after production process, example, after gas turbine of electric generator) and sea water. By using the temperature difference productively, this method needs comparatively small energy input -- only for pumping water and air, not for heating or cooling. This new environmentally friendly method may be used at any point in the Earth located not far from any sea. There are three working versions: (1) Underwater heater and tube cooler; (2) Douche heater and douche cooler; (3) Underwater heater and underwater cooler.

The installation also clears the exhaust gas from ashes and soot, sulfur dioxide (SO<sub>2</sub>). The water having the high concentration carbon dioxide (CO<sub>2</sub>) may be used for growing algae for biofuel and feed.

**Key words:** Extraction freshwater, method of getting freshwater, receiving energy from exhaust gas, using the hot exhaust gas.

### Introduction

Industry of any country are uses millions tons of fuel annually (2005-2007, Oil & Gas Journal, World Oil).

1. Oil: 84 million barrels used per day.
2. Gas: 19 million barrel equivalent used per day.
3. Coal: 29 million barrel equivalent used per day.

The Energy Information Administration estimates that in 2005, 86% of primary energy production in the world was from burning fossil fuels, with the remaining non-fossil sources being hydroelectric 6.3%, nuclear 6.0%, and other (geothermal, solar, wind, and wood and waste) 0.9 percent.

The burning of fossil fuels produces around 21.3 billion tons (= 21.3 gigatons) of carbon dioxide per year, but it is estimated that natural processes can only absorb about half of that amount, so there is a net increase of 10.65 billion tons of atmospheric carbon dioxide per year (one ton of atmospheric carbon is equivalent to 44/12 or 3.7 tons of carbon dioxide). Carbon dioxide is one of the greenhouse gases that enhances radiative forcing and contributes to global warming, causing the average surface temperature of the Earth to rise in response, which climate scientists agree will cause major adverse effects, including reduced biodiversity and, over time, cause sea level rise.

A **Freshwater** body contains low concentrations of dissolved salts and other total dissolved solids. It is an important renewable resource, necessary for the survival of most terrestrial organisms, and required by humans for drinking and agriculture, among many other uses.

Freshwater can be defined as water with less than 0.5 parts per thousand dissolved salts. Freshwater bodies include lakes, rivers, and some bodies of underground water. The ultimate source of fresh water is the precipitation of atmosphere in the form of rain and snow.

Access to unpolluted fresh water is a critical issue for the survival of many species, including humans, who must drink fresh water in order to survive. Only three percent of the water on Earth is freshwater in nature, and about two-thirds of this is frozen in glaciers and polar ice caps. Most of the rest is underground and only 0.3 percent is surface water. Freshwater lakes contain seven-eighths of this fresh surface water. Swamps have most of the balance with only a small amount in rivers.

An estimated 15% of world-wide water use is for household purposes which include drinking water, bathing, cooking, sanitation, and gardening. Basic household water requirements are around 50 liters per person per day, excluding water for gardens. Many countries and regions do not have enough freshwater.

**Desalination** refers to any of several processes that remove the excess salt and other minerals from water in order to obtain fresh water suitable for animal consumption or irrigation, and if almost all of the salt is removed for human consumption, sometimes the process produces table salt as a by-product. Desalination of ocean water is common in the Middle East (because of water scarcity) and the Caribbean, and is growing fast in the USA, North Africa, Singapore, Spain, Australia and China.

Desalination of brackish water is done in the United States in order to meet treaty obligations for river water entering Mexico. Several Middle Eastern countries have energy reserves so great that they use desalinated water for agriculture. Saudi Arabia's desalination plants account for about 24% of total world capacity.

Numerous methods for desalination exist including: Distillation, Evaporation/condensation, and Multiple-effect. Membrane processes, Electrodialysis reversal, Nanofiltration, Freezing, Solar humidification, Methane hydrate crystallization, vacuum distillation, and so on. What they have in common is that they all require a great deal of energy and, as a result, produce freshwater at a high cost. The largest desalination plant in the United States is located in Tampa Bay, Florida, which began desalinating 25 million U.S. gallons (95,000 m<sup>3</sup>) of water per day in December 2007.

**Economics.** A number of factors determine the capital and operating costs for desalination: capacity and type of facility, location, feed water, labor, energy, financing and concentrate disposal. Desalination stills now control pressure, temperature and brine concentrations to optimize the water extraction efficiency. Nuclear-powered desalination might be economical on a large scale, and there is a pilot plant in the former USSR.

Critics point to the high costs of desalination technologies, especially for poor third world countries, the impracticability and cost of transporting or piping massive amounts of desalinated seawater throughout the interiors of large countries, and the "lethal byproduct of saline brine that is a major cause of marine pollution when dumped back into the oceans at high temperatures". While noting that costs are falling, and generally positive about the technology for affluent areas that are proximate to oceans, one study argues that "Desalinated water may be a solution for some water-stress regions, but not for places that are poor, deep in the interior of a continent, or at high elevation. Unfortunately, that includes some of the places with biggest water problems. Indeed, one needs to lift the water by 2000 m, or transport it over more than 1600 km to get transport costs equal to the desalination costs. Thus, desalinated water is only really expensive in places far from the sea, like New Delhi, or in high places, like Mexico City. Desalinated water is also expensive in places that are both somewhat far from the sea and somewhat high, such as Riyadh and Harare. In other places, the dominant cost is desalination, not transport. This leads to relatively low costs in places like Beijing, Bangkok, Zaragoza, Phoenix, and, of course, coastal cities like Tripoli.



**Exhaust gas** is flue gas which occurs as a result of the combustion of fuels such as natural gas, gasoline/petrol, diesel, fuel oil or coal. It is discharged into the atmosphere through an exhaust pipe or flue gas stack. Since ambient air contains about 79 volume percent gaseous nitrogen ( $N_2$ ), which is essentially non-combustible, the largest part of the flue gas from most fossil fuel combustion is uncombusted nitrogen. The next largest part of the flue gas is carbon dioxide ( $CO_2$ ) which can be as much as 10 to 15 volume percent or more of the flue gas. This is closely followed in volume by water vapor ( $H_2O$ ) created by the combustion of the hydrogen in the fuel with atmospheric oxygen. Much of the 'smoke' seen pouring from flue gas stacks is this water vapor forming a cloud as it contacts cool air.

Although the largest part of most combustion gases is relatively harmless nitrogen ( $N_2$ ), water vapor ( $H_2O$ ) (except with pure-carbon fuels), and carbon dioxide ( $CO_2$ ) (except with hydrogen as fuel), a relatively small part of it is undesirable noxious or toxic substances, such as carbon monoxide ( $CO$ ), hydrocarbons, nitrogen oxides ( $NO^2$ ), partly unburnt fuel, and particulate matter. A typical flue gas from the combustion of fossil fuels will also contain some very small amounts of sulfur dioxide ( $SO_2$ ).



Exhaust gas from an industrial plant

### Description of offered method

This method uses the exhaust industrial gases for producing the fresh-water and decreasing smoke in atmosphere. Currently, electric, heat and other industry plants discharge into the atmosphere hot exhaust gas after burning natural gas, oil, coal or other fossil fuel. This hot gas contains water vapor and a great deal of heat energy which can be used for production of fresh water. Our proposal utilizes this energy for conversion the water vapor and sea water into the fresh water. We offer three simple and cheap installations connected with electric, heat or other industry plants which produce exhaust gas which otherwise would otherwise be discharged into the atmosphere, polluting the environment.

The installation can create hundreds of thousands tons of freshwater per year. This fresh water is very cheap because installations are cheap and require very little energy for a flow of the exhaust gas through the installation. In addition, the offered installation clears the exhaust gas from ashes, soot and sulfite  $SO_2$ . The carbon dioxide,  $CO_2$ , rather can contributing to global warming can be utilized constructively by solubility in sea water and production of algae is utilized in manufacturing artificial oil.

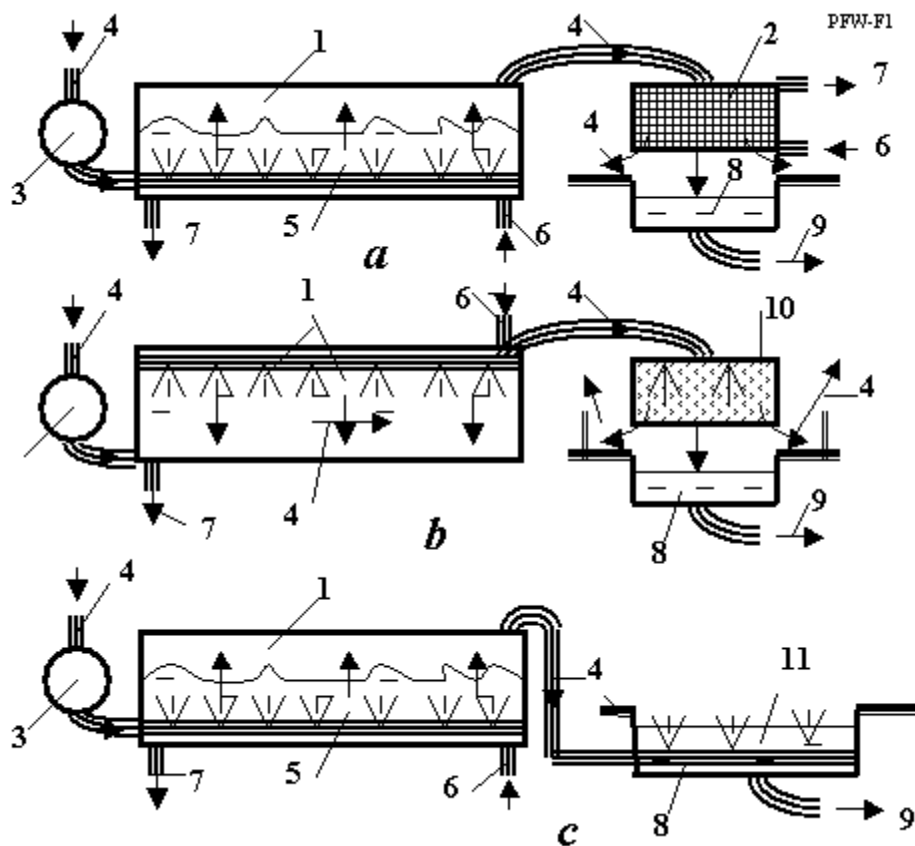
The suggested installations (gas desalters) are shown in Fig.1. The first version (Fig.1a) contains the underwater evaporator (heater) and tube cooler. The ventilator 3 moves the hot exhaust



gas through a thin (5 – 10 cm) layer of sea water into the boiler 1, heats the sea water up 100°C and vaporizes it. The exhaust gas conventionally contains 5-15% of water vapor. After boiler the gas contains about 70% of water vapor (see computation below). This gas goes to the cooler 2 (it may be conventional tube radiator) where the sea water having the temperature 15-25°C cools the gas up 30°C and about 95% of vapor condenses into fresh water.

The second version (Fig.1b) contains a douche evaporator (heater) 1 and a douche cooler 10. The refrigerant takes the fresh water from a special open reservoir. After condensation of vapor the amount of fresh water and temperature increases. The atmospheric air cools the warm fresh water in the open large reservoir.

The third version (Fig.1c) has the underwater heater (evaporator) 1 and underwater cooler 11. The exhaust gas is blown out through tubes having a lot of small holes. The tubes located under water layer 5 – 10 cm. The evaporator is layer of the sea water. The hot gas evaporates sea water. The hot mixture gas has temperature 100°C and contains about 70% water vapor. Gas is blown out through tubes having a lot of small holes and located in the cooler. The tubes located under water layer 5 – 10 cm. The underwater cooler contains the fresh water and has a large surface. The gas temperature decreases up 30°C. The 95% of vapor condenses into fresh water. The water cools in open reservoir.



**Fig.1.** Gas desalter of sea water. a) Underwater evaporator (heater) and tube cooler; b) Douche heater (evaporator) and douche cooler; c) Underwater evaporator (heater) and underwater cooler. Notations: 1 – heater (boiler, evaporator); 2 – cooler-radiator; 3 – gas pump (ventilator); 4 – exhaust gas; 5 - sea water; 6 – sea water enter; 7 – sea water exit; 8 – fresh water; 9 – exhaust gas exit; 10 – douche cooler; 10 – underwater cooler.

## Computations and Estimations

A reader may derive the equations below from well-known physical laws. Therefore, the authors do not give detailed explanations.

1. **Amount of water in atmosphere.** Amount of water in a given body of air depends upon temperature and humidity. For relative humidity = 100% the maximum partial pressure of water vapor is shown in Table 1.

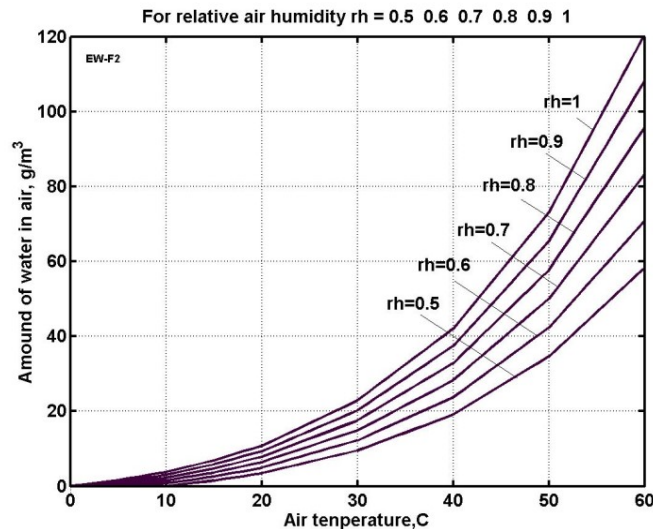
**Table 1.** Maximum partial pressure of water vapor in atmosphere via air temperature

t, C	-10	0	10	20	30	40	50	60	70	80	90	100
p,kPa	0.287	0.611	1.22	2.33	4.27	7.33	12.3	19.9	30.9	49.7	70.1	101

The amount of water in 1 m<sup>3</sup> of air may be computed by equation

$$m_w = 0.00625 [p(t_2)h - p(t_1)], \quad (1)$$

where  $m_w$  is mass of water, kg in 1 m<sup>3</sup> of air;  $p(t)$  is vapor (steam) pressure from Table 1, relative  $h = 0 \div 1$  is relative humidity. The computation of equation (1) is presented in fig.2. Typical relative humidity of atmosphere air is 0.5 - 1.



**Fig. 2.** Amount of water in 1 m<sup>3</sup> of air versus air temperature and relative humidity (rh).  $t_1 = 0$  °C.

### 2. Heat capacity of fuel.

*Heat of combustion (MJ/kg):*

Benzene 44	Mazut 30–41	Natural gases 42–47	Wood 15-30
Diesel fuel 43	Spirit 27.2	Hydrogen 120	Peat 6 –11
Kerosene 43	Coal 15–27	Acetylene 48	gunpowder 3

3. **Amount of fuel per year and pollution** of ashes and soot by the heat-electric plant of power 1000 MW (typical electric power has 2000 - 5000 MW).

Finger/Used fuel	Coal	Mazut	Natural gas
------------------	------	-------	-------------

Mass of fuel per 1 year, ton	$2.3 \times 10^6$	$1.6 \times 10^6$	$1.5 \times 10^6$
Mass of ashes and soot, ton	4500	730	460
Mass of exhaust gas, ton*	$7.2 \times 10^6$	$6.4 \times 10^6$	$6.84 \times 10^6$

\* Together with water vapor.

The main part (up 98%) of natural gas is methane CH<sub>4</sub>.

### Project

#### getting the freshwater by exhaust gases of the electric plants used natural gas.

- 1) Let us to compute the freshwater received from burning the 1 kg of natural gas after it is using gas by electric plant (using hot exhaust gas after electric turbine). The natural gas is methane (about 95%) CH<sub>4</sub> (molecular mass is 18). After burning we get the CO<sub>2</sub> (m. mass is 46) and 2H<sub>2</sub>O (m. mass is 36). Together with air nitrogen the exhaust gas has m-mass 274. About  $36/274 = 12\%$  of exhaust gas is water vapor or 1 kg of fuel gas produced  $36/18 = 2$  kg of water.
- 2) The natural gas has the heat capability  $45 \times 10^6$  J/kg. Efficiency coefficient of typical electric plant is  $\eta = 0.3$ . Consequently, the exhaust gas contains 70% of fuel energy,

$$Q = 0.7 \times 45 \times 10^6 = 31.5 \text{ MJ.}$$

- 3) The vapor thermal capacity is  $r = 2260$  kJ/kg, the water heat capacity is  $c_p = 4.19$  kJ/kg/K. That means about 87% of the gas energy may be used for evaporation of sea water. Mass of vapor is

$$m_w = \frac{0.7 \cdot 0.87 \cdot 45 \cdot 10^6}{2.26 \cdot 10^6} = 12.13 \text{ kg.}$$

**Summary result:** 1 kg of natural gas can produce about  $2+12 = 14$  kg of fresh water.

- 4) Requested sea water for cooling (from 100 to 30°C) is

$$m_c = \frac{Q}{c_p \Delta T} = \frac{31.5 \cdot 10^6}{4.19 \cdot 10^3 \cdot 70} = 110 \text{ kg.}$$

- 5) Let us take the heat transfer condense coefficient  $k = 2500$  W/m<sup>2</sup>K (water vapor – water) [23] the requested gas radiator surface for abarage gradient of temperature  $70/2 = 35$  C is

$$S_r = \frac{Q}{k \Delta T} = \frac{31.5 \cdot 10^6}{2500 \cdot 35} = 360 \text{ m}^2.$$

The forward radiator area is less in 30 - 40 times. It is about  $360/36 = 10$  m<sup>2</sup> or  $3.2 \times 3.2$  m.

- 6) **Productivity.** The 1 kg/s of fuel is equivalent of plant power  $P = \eta Q = 0.3 \times 45 \times 10^6 = 13.5$  MW. The average electric plant has power 2000 - 5000 MW. If the electric plant has power  $P = 3000$  MW the fuel consumption is  $3000/13.5 = 222$  kg/s and the fresh water production is

$$m_w = \frac{3000}{13.5} \cdot 14 = 3.1 \text{ kL/s} = 11.16 \cdot 10^3 \text{ ton/hour} = 268 \cdot 10^3 \text{ ton/day} = 96 \cdot 10^6 \text{ ton(m}^3\text{)/year.}$$

*Note:* That is 2.8 times more then the most power desalted plant in the USA in Tampa Bay, Florida, which began desalinating 25 million U.S. gallons (95,000 m<sup>3</sup>) of water per day in December 2007.

- 7) **Economics.** The cost of installation is about \$500K - \$1000K. Lifespan of the installation is 10 - 25 years. Maintenance about \$50K/year. Power of ventilators is 50 kW. Production cost of fresh water is \$0.03-0.08/m<sup>3</sup>. If retail price is \$0.5/m<sup>3</sup>, profit exceeds \$50M/year.

### Conclusion

Author began this research as investigation of new method for obtaining cheap freshwater from the atmosphere [17]. In processing the research he discovered that the method he was studying might be simplified if we would employ the exhaust gas for evaporation and sea water for cooling. The method does not need unknown or unusual technology. The methods of computation and estimation are developed.

### References

(The reader find some author's works in <http://Bolonkin.narod.ru/p65.htm>, <http://Arxiv.org> Search: "Bolonkin" and books: Bolonkin A.A., Non-Rocket Space Launch and flight:, Elsevier, 2006, 488 pgs., Bolonkin A.A.,

- “New Concepts, ideas, and Innovations in Technology and Human life”, NOVA, 2008, 502 pg., Macro-Projects: Environment and Technology, NOVA, 2009, 536 pgs)
1. Bolonkin, A.A., (2002), “Optimal Inflatable Space Towers of High Height”. COSPAR-02 C1.1-0035-02, 34th Scientific Assembly of the Committee on Space Research (COSPAR), The World Space Congress – 2002, 10–19 Oct 2002, Houston, Texas, USA.
  2. Bolonkin, A.A., (2003), “Optimal Inflatable Space Towers with 3-100 km Height”, *JBIS*, Vol. 56, No 3/4, pp. 87–97, 2003.
  3. Bolonkin A.A.,(2004a), “Kinetic Space Towers and Launchers ‘ , *JBIS*, Vol. 57, No 1/2, pp. 33–39, 2004.
  4. Bolonkin A.A., (2004b), Utilization of Wind Energy at High Altitude, AIAA-2004-5705, AIAA-2004-5756, International Energy Conversion Engineering Conference at Providence., RI, Aug.16-19. 2004. USA. <http://arxiv.org> .
  5. Bolonkin A.A., (2006a), Optimal Solid Space Tower, AIAA-2006-7717. ATIO Conference, 25-27 Sept. 2006, Wichita, Kansas, USA. <http://arxiv.org> , search "Bolonkin".
  6. Bolonkin A., Cathcart R., (2006b). A Low-Cost Natural Gas/Freshwater Aerial Pipeline. <http://arxiv.org> , search "Bolonkin".
  7. Bolonkin A.A., (2006c) Cheap Textile Dam Protection of Seaport Cities against Hurricane Storm Surge Waves, Tsunamis, and Other Weather-Related Floods. <http://arxiv.org> , search "Bolonkin".
  8. Bolonkin A.A., (2006d) Non-Rocket Space Launch and Flight, Elsevier, 2006, 488 ps.
  9. Bolonkin A., Cathcart R., (2006e). The Java-Sumatra Aerial Mega-Tramway, <http://arxiv.org> .
  10. Bolonkin A., Cathcart R., (2006f). Inflatable Evergreen Polar Zone Dome (EPZD) Settlements. <http://arxiv.org> , search "Bolonkin".
  11. Bolonkin, A.A. and R.B. Cathcart, (2006g) “A Cable Space Transportation System at the Earth’s Poles to Support Exploitation of the Moon”, *Journal of the British Interplanetary Society* 59: 375-380.
  12. Bolonkin A., (2006h). Control of Regional and Global Weather. <http://arxiv.org> , search "Bolonkin".
  13. Bolonkin A., Cathcart R., (2006i). Antarctica: A Southern Hemisphere Windpower Station? <http://arxiv.org> , search "Bolonkin".
  14. Bolonkin, A.A. and R.B. Cathcart (2006j), “Inflatable ‘Evergreen’ dome settlements for Earth’s Polar Regions”, *Clean Technologies and Environmental Policy* DOI 10.1007/s10098-006-0073-4.
  15. Cathcart R., Bolonkin A., (2006k),The Golden Gate Textile Barrier: Preserving California Bay of San Francisco from a Rising North Pacific Ocean. <http://arxiv.org>. Search: "Bolonkin".
  16. Cathcart R., Bolonkin A., (2006l), Ocean Terracing, <http://arxiv.org> . Search: "Bolonkin".
  17. Bolonkin A.A., (2006m), Extraction of Freshwater and Energy from Atmosphere. <http://arxiv.org>. Search: "Bolonkin".
  18. Bolonki A.A., Cathcart R.,(2008). Macro-Projects:Technology and Inviroment, NOVA, 470 p.
  19. Book (2006),: *Macro-Engineering - A challenge for the future*. Collection of articles. Eds. V. Badescu, R. Cathcart and R. Schuiling, Springer, (2006). (Collection contains Bolonkin's articles: Space Towers; Cable Anti-Gravitator, Electrostatic Levitation and Artificial Gravity).
  20. Gleick, Peter; et al. (1996). in Stephen H. Schneider: *Encyclopedia of Climate and Weather*. Oxford University Press.
  21. [Encyclopedia of Desalination and water and Water Resources](#)
  22. [Encyclopedia of Earth - Surface water management](#) .
  23. <http://www.cheresources.com/uexchangers.shtml> .

## Chapter 3B

# Solar Distiller\*

### Abstract

This unique method for the extraction of fresh water (desalination of sea water) by solar energy entails the following: (1) Installation of the desalination system occurs on the sea and, as such, does not require expensive coastal land surface; (2) Desalination uses solar energy which produces fresh water at a cost close to zero; (3) The device is made from thin film which is less costly than the conventional reverse osmotic or multi flash plants; (4) Ecologically sound, the desalination device uses sea waves for water and wet air circulation; (5) Highly transportable, the desalination device may be delivered anywhere on water through shipping lanes; (6) Preassembled or disassembled, the desalination device is very compact and easily stored in conventional storehouses; (7) The desalination device also functions as a rain water collector; (8) Environmentally friendly, the desalination system does not dump brine, which is hazardous to marine life, into the water; (9) A portable, inexpensive version of the seawater distiller is available to help travelers produce water when in need.

-----

**Key words:** desalination, desalinization, desalination of sea water, purification of polluted water, distiller, using solar energy for desalination.

\* This chapter uses the article [1] was written by author together with S. Neuman and J. Friedlander

### Introduction

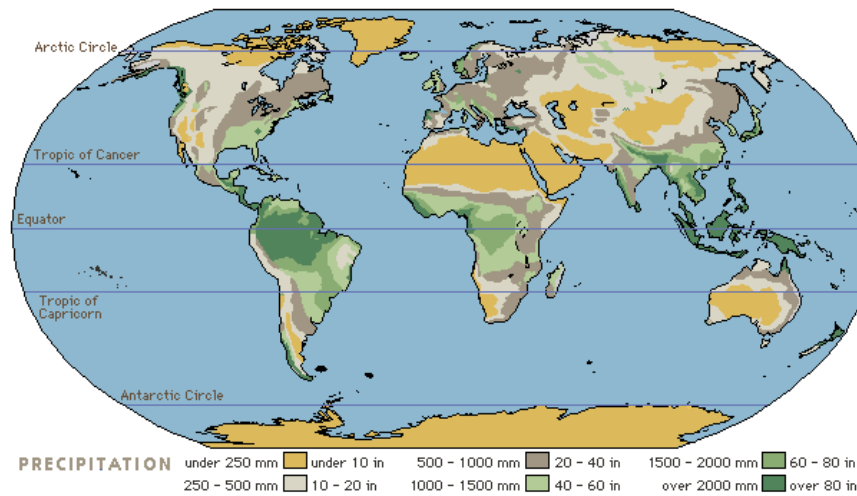
#### **What is desalination?**

Desalination or desalinization refers to any of several processes that remove excess salt and other minerals from water; it can also refer to processes such as soil desalination. The focus of this article, however, is on water desalination. Salty water is desalinated in order to be converted to freshwater suitable for animal consumption, irrigation and if almost all of the salt is removed, for human consumption. Sometimes desalination produces table salt as a byproduct.

Most of the modern interest in desalination is focused on developing cost-effective ways of providing fresh water for human use in regions where the availability of water is limited, such as on ships and nuclear submarines. In instances in which vast land regions are separated from a freshwater source, sometimes large-scale desalination is required. Large-scale desalination typically requires substantial amounts of energy as well as specialized, expensive infrastructure, making the process costly when juxtaposed to the cost of freshwater from rivers or groundwater. Nonetheless, Middle Eastern countries' large energy reserves coupled with their profound water scarcity have led to an extensive construction of desalination. Saudi Arabia's desalination plants, for instance, account for about 24% of the world's total capacity.

The world's largest desalination plant is the Jebel Ali Desalination Plant (Phase 2) in the United Arab Emirates. It is a dual-purpose facility that uses multi-stage flash distillation and is capable of producing 300 million cubic meters of water per year. In addition, the largest desalination plant in the United States, located in Tampa Bay, Florida, began desalinating 36.5 million cubic meters of saltwater per year in December 2007. The Tampa Bay plant produces approximately 12% the output of the Jebel Ali Desalination Plants.

The growing phenomena of desalinations were noted in a Wall Street Journal article in January 2008. “World-wide, 13,080 desalination plants produce more than 12 billion U.S. gallons (45,000,000 m<sup>3</sup>) of water a day, according to the International Desalination Association (Wall Street Journal 2008).



**Fig.1a.** World Precipitation and Average Rainfall

### What methods are used for desalination?

As of July 2004, the two leading desalination methods were reverse osmosis (47.2% of installed capacity world-wide) and multi-stage flash (36.5%). The traditional process used in these operations is vacuum distillation, which entails boiling the water at less than atmospheric pressure and at a much lower temperature than normal. Energy was saved because (1) liquid boils when the vapor pressure equals the ambient pressure, and (2) vapor pressure increases with temperature.

In the last decade, most new facilities used reverse osmosis technology, membrane processes which utilize semi-permeable membranes and pressure to separate salts from water. These processes typically use less energy than thermal distillation, which has led to a reduction in overall desalination costs over the past decade. Desalination remains energy intensive, however, and future costs will continue to depend on the price of both energy and desalination technology, examples of which include: capacity and type of facility, location, feed water, labor, energy, financing and concentrate disposal.

### Is there any criticism of desalination?

Critics of desalination claim: (1) The high cost of desalination technologies is especially arduous for impoverished third world countries; (2) Desalination leads to a byproduct of concentrated seawater, which some environmentalists have claimed is a major cause of marine pollution when it is dumped back into the oceans at high temperatures; (3) The transporting or piping of massive amounts of desalinated seawater throughout the interiors of large countries is impracticable and cost intensive.

In response to the first criticism, desalination is certainly more suitable for affluent, coastal regions than poor regions situated in the interior of a continent or at high elevation. The latter area requires transport of fresh water from another location as opposed to desalination. Indeed, one needs to lift the water by 2000 m, or transport it over more than 1600 km for transport costs to equal desalination costs.



In regard to the second criticism, the reverse osmosis technology that is used to desalinate water typically does not produce “hot water” as a byproduct. Additionally, depending on the prevailing currents of receiving waters, the seawater concentrate byproduct can be diluted and dispersed to background levels within relatively short distances of the ocean outlet.



**FIG.2A.** ASHKELON SEAWATER REVERSE OSMOSIS (SWRO) DESALINATION PLANT, ISRAEL. PRODUCTIVITY 50M M<sup>3</sup>/YEAR (2006). COST USD \$250M. (PICTURE HAS 34K).

In light of the third criticism, geography plays a strong role in desalination costs. In places far from the sea, such as New Delhi (India) or in high places, like Mexico City (Mexico), high transport costs add to the high desalination costs. Desalinated water is also expensive in places that are both somewhat far from the sea and somewhat high, such as Riyadh and Harare. In places close to the ocean, on the flip side, the dominant cost is desalination, not transport; therefore desalination process would be therefore be less expensive in places like Beijing (China), Bangkok (Thailand), Zaragoza, Phoenix, and, coastal cities like Tripoli (Lebanon).

Desalinations' cost effectiveness compared with other water supply options, which include mandatory installation of rainwater tanks or storm water harvesting infrastructure have led many large coastal cities in developed countries to consider the feasibility of seawater desalination. Two such countries are Israel, which now desalinizes water at a cost of \$0.53 per cubic meter and Singapore, which is desalinizing water at \$0.49 per cubic meter.

A prime example of country that has tapped into the incredible resource of desalination is Australia. Numerous studies have shown that desalination is among the most cost-effective options for boosting the water supply in major Australian state capitals. The city of Perth (Australia) has been successfully operating a reverse osmosis seawater desalination plant since 2006, and the West Australian government has announced that more plants will be built in Australia's largest city, Sydney, and Wonthaggi, Victoria in the near future.

Australia's decentralization plants are the paradigm of environmentally friendly. The Perth desalination plant, for example is powered partially by renewable energy from the Emu Downs Wind Farm. In addition, the Sydney plant will be powered entirely from renewable sources, thereby



eliminating harmful greenhouse gas emissions to the environment, a common argument used against seawater desalination due to the energy requirements of the technology.



**Fig.3a.** The Tampa Bay, Florida (USA) desalination plant: A series of failures and costly delays. 25 million gallons of fresh drinking water per day ( $34\text{M m}^3/\text{year}$ ) so desperately needed in the parched region even after it was repaired and reopened in 2007 as “fully operational”. In late 2007, more than 7 years after construction began, the plant finally became operational, but the price of construction rose to \$158 million and the cost of water from the plant for consumers went from an estimated \$677 to \$1,100 per acre foot (1 acre = 0.405 he = 4.8 yd<sup>2</sup>).

Renewable resources, although ecologically friendly, add to the operating costs of desalination. However, recent experience in Perth and Sydney indicates that the additional cost is acceptable to communities because it allows them to augment their water supply without doing environmental harm to the atmosphere. As a result, The Gold Coast desalination plant, a plant soon to be built in Australia, will be powered entirely from fossil fuel. At a rate of over 4 kWh per cubic meter to produce, this will be the most expensive source of water in Australia. One way to fund the exorbitant cost of desalination is raising water prices. The desalination plant in Adelaide, Australia located at Port Stanvac, for instance, will be funded by raising water rates to achieve full cost recovery.

In summary, as illustrated by the examples of the rising number of desalination plants in the Middle East, the United States, Australia, counties are very interested in investing in desalination plants. In order to better understand the weighty costs of the desalination plants, it is necessary to discuss the process by which water is typically desalinated, reverse osmosis.

*Reverse osmosis* (RO) is a separation process that uses pressure to force a solution through a semi-permeable membrane; the solute is retained on one side where as the pure solvent is allowed passage to the other side. In reverse osmosis, a solvent moves from a region of high solute concentration through a membrane to a region of low solute concentration. As the name implies, reverse osmosis is the reversal of the normal osmosis process, the natural movement of solvent from an

area of low solute concentration through a membrane, to an area of high solute concentration when no external pressure is applied.

The membranes that are used for reverse osmosis have a dense barrier layer in the polymer matrix where most separation occurs. In most cases the membrane is designed to only allow water to pass through a dense layer while preventing the passage of solutes (such as salt ions). This process requires that a high pressure be exerted on the high concentration side of the membrane, usually 2–17 bar (30–250 psi) for fresh and brackish water and 40–70 bar (600–1000 psi) for seawater, which has around 24 bar (350 psi) natural osmotic pressure that must be overcome.

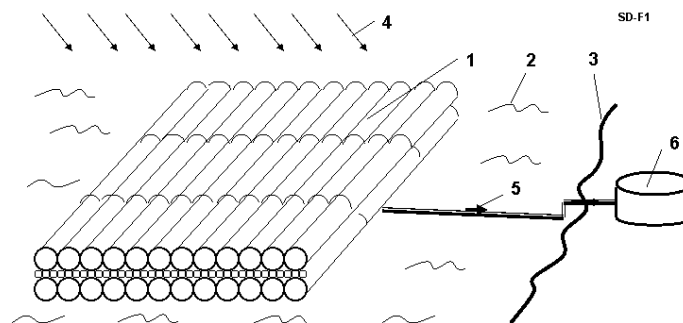
The desalinated water that is produced is very corrosive and thus is “stabilized” to protect downstream pipelines and storages, usually by adding lime and carbon dioxide to prevent the corrosion of concrete or cement lined surfaces. Moreover, liming material is used in order to adjust the pH from 6.8 to 8.1 to meet the potable water specifications, primarily for effective disinfection and for corrosion control. Additionally, although desalination processes are very effective barriers to pathogenic organisms, disinfection is used to ensure a “safe” water supply.

Reverse osmosis units sold for residential purposes offer water filtration at the cost of large quantities of waste water. For every 5 gallons of output, a typical residential reverse osmosis filter will send around 10 – 20 gallons of water down the drain although it may be captured and used for watering plants and lawns. The substantial waste, however, can be minimized greatly through using our efficient method of desalinization that is outlined below.

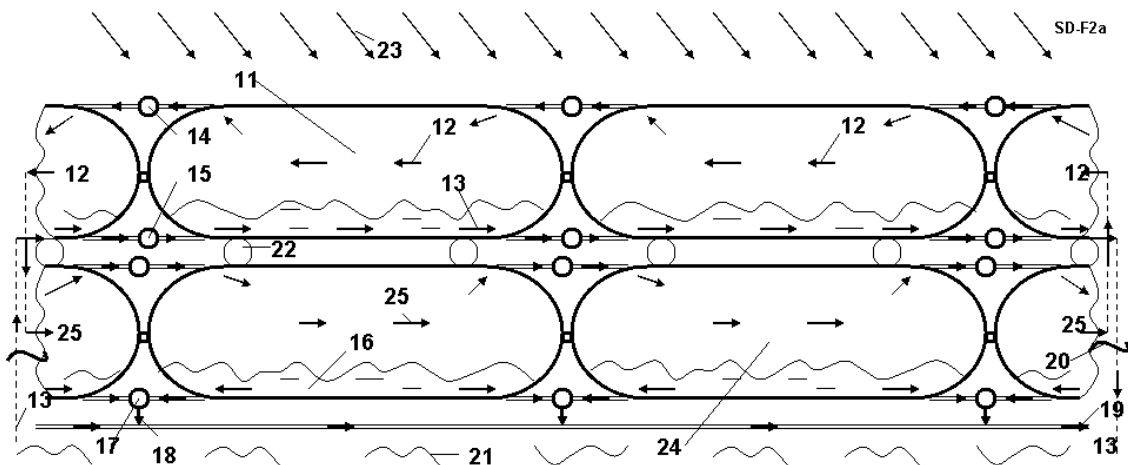
### **An Innovative Solar Desalinization System**

Our solar desalination system has two layers of film tubes divided by partitions into sections connected by back valves for air (vapor) and water (fig.1). The top layer of the tubes contains sea water and air; the lower layer of the tubes contains fresh water and air (fig.2). Solar radiation (70 - 80°C) heats the sea water in the top tube layer which evaporates the water. The moist air (vapor) is then forced to a lower tube layer, which is cooled by sea water (up 25°C), and then condenses into fresh water which is pumped to coast.

The tubes are separated into sections (fig.2) connected by unidirectional back valves on top (14) and on bottom (15). In the top tube layer, the top valves push the wet air vapor (12) in one direction. The lower valves pass the sea water (13) in the opposite direction. The lower valves (17) pass the condensate (fresh water) into under water tubes and to ground or fresh water storage (16). The sea waves then compress and decompress the inflatable tube sections and pumping the wet air, sea and fresh water. In addition, the wet air (vapor) and water may use small electric pumps (ventilators) for circulation.



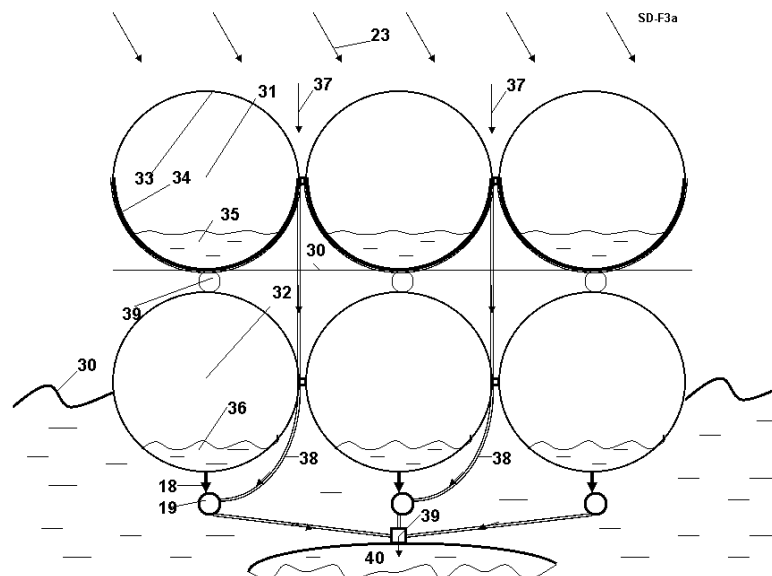
**Fig.1.** Solar Sea Distiller. *Notation:* 1 – film tubes; 2 – sea; 3 – coast; 4 – solar radiation; 5 – fresh water tube and pump; 6 – fresh water storage.



**Fig.2.** Longitudinal Cross section of Solar Sea Distiller. *Notations:* 11 – section of flexible tube; 12 – air wet (vapor) flow; 13 – sea water flow; 14, 15, 17 – unidirectional fluid valves (other names: one direct (direction) valves, back valves, inverted valves, return valves, holding valves) ; 16 – fresh water; 17 – back valve; 18, 19 – fresh water flow; 20 – sea surface; 21 - sea; 22 – hear protection; 23 – solar radiation; 24 – lower tube; 25 – air flow in lower tube layer.

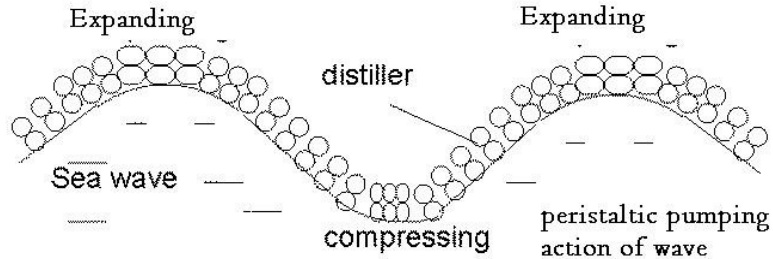
Rain water (37) then flows into tubes 38 to the fresh water storage 40 (fig.3). The float installation has special protection top tube layer against the sea water (fig.6).

In order to increase absorption of the solar radiation the lower part 34 of top tubes (fig.3) is black. The material of the top tube passes the solar radiation but reduces heat losses upwards. In addition, the top part of 33 is transparent. Below the top tube the heat reflector 30 is located (fig. 3). The reflector blocks the lower tubes from the heat radiation from the upper heat tubes.

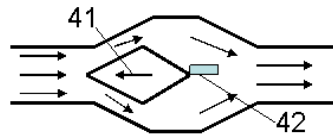


**Fig.3.** Diametrical cross section of Solar Sea Distiller. *Notations:* 30 – heat reflector; 31 – top film tubes; 32 – lower film tubes; 33 – transparent top part of top tube; 34 – black lower part of top tube; 35 – sea water; 36 – fresh water in lower tubes; 37 – rain; 38 – rain fresh water tube; 39 – back valve; 40 – fresh water storage; 30 – sea surface; 23 – solar radiation; 18, 19 – tubes for fresh and rain water.

The sea waves periodically expand and compress the inflatable sections of tubes and the moving the air (vapor) and flowing sea water (fig.4). The back valves (fig.5) allow the flow to move only in given direction. Air and sea water, for example, flows into the top layer in opposing directions. The air (vapor) flows from the top layer and moves into the lower layer where it is cooled by the sea through thin film lower tubes, where it condenses and fresh water flows into the fresh water storage 40 (fig.3).



**Fig.4.** Explanation pumping the air and sea water through tubes of Distiller by sea waves. Sea waves alternately compress and expand the separate sections of the flexible inflatable tubes. The back valves allow the air and sea water into tubes to flow only in given direction.

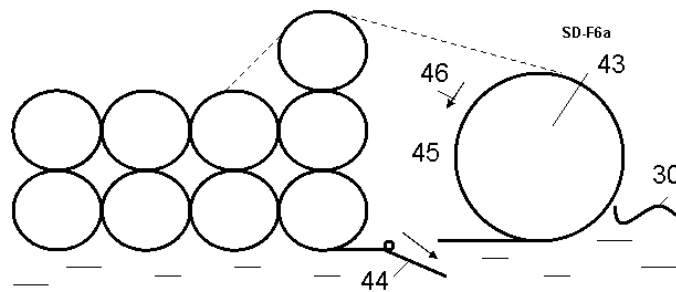


**Fig.5.** Typical action of back valve

(one direction valve, inverted valve, (non) return valve, holding valve). Notation: 41 – valve, 42 – string.

Working principle: The pressure is high on left side that opens the internal valve 41 (compresses the weak spring 42) and substance (air, water) overflows from left to right. When pressure is higher on right side, it closes the hole and stops the back flow.

The top surface of the distiller is protected from the strong sea waves by special inflatable barrier 43 (fig.6). When a top of sea wave is over the barrier tube (43) the sea water flows into space 45 and through the back valve (44) goes back into the sea.

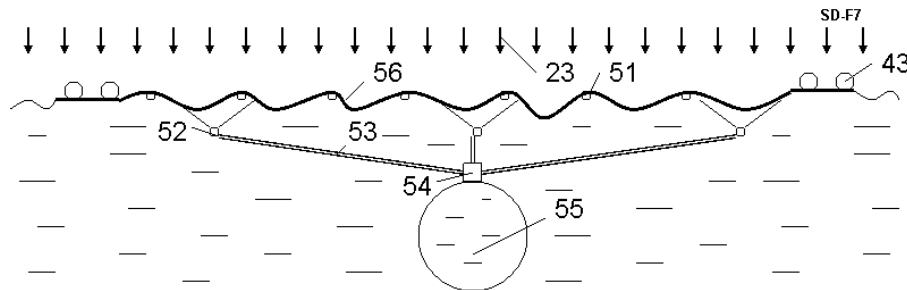


**Fig.6.** Barrier against surge of sea water over surface of distiller.

*Notations:* 43 – inflatable barrier tube; 44 – back valve; 45 – internal space between the barrier tube and Distiller; 46 – water of a sea wave. *Work:* when a top of sea wave is over the barrier tube 43, the sea water flows into space 45 and through the back valve 44 goes back to the sea.

The Solar Desalination System can also work on land. In this instance, the lower tube layer is cooled by air. However the productivity significantly decreases. An inexpensive portable version of the offered system may be included in soldier or travelers accoutrements for production of fresh water in the desert so they would be able to distill fresh water from bad water or urine.

The simplest (rain and dew) version of system is shown in fig.7. Thin film is located over sea surface and provides a barrier against big sea waves. It can also collect rain and (early and night) dew fresh water. The rain and dew water flows to the fresh water storage (55) from small plumb (52) through rain tube (53) and black valve (54). The film can have a high reflectivity surface. If it covers a large area the sea water will have significantly lower temperature (solar radiation does not heat the sea water). Thus the quantity of the night dew water is improved.



**Fig.7.** Simplest collector of rain fresh water on sea and dew. *Notations:*; 51 – support float (optional); 52 – small plumb; 53 – rain water tube; 54 – back valve, 55 – inflatable storage of rain and dew fresh water; 56 – thin film; 43 – barrier against sea waves; 23 – rain.

*Work:* the rain and dew water flows to the fresh water storage and pumps to customer.

### Summary of our system's innovations and advantages:

- 1) Located on the sea and, the system does not require expensive coastal land surface;
- 2) The devise is made from inexpensive thin film, making the system more affordable than the conventional reverse osmotic or multi flash plants;
- 3) Installation uses solar energy which produces fresh water at a cost close to zero;
- 4) Sea waves are used for water and wet air circulation;
- 5) The system may be delivered anyplace on water and easily transported so that it can be an at sea source of fresh water to ships along shipping lanes;
- 6) Preassembled or disassembled, it is very compact and easily stored in conventional storehouses;
- 7) The installation may be also used for collection the rain water and dew water;
- 8) The Solar Sea Distiller is environmentally friendly as it does not dump brine in limited place which is hazardous to marine life.

### Computation and estimation

A reader can derive the equations below from well-known physical laws. Therefore, no detailed explanations of these are furnished here.

1. **Estimation of a maximal theoretical productivity of a solar distiller.** The power of a solar radiation out of atmosphere is  $1400 \text{ W/m}^2$ . After atmospheric losses, the average solar radiation in a clear day at the middle latitude  $0 \div (30^\circ - 40^\circ)$  is about  $1000 \div 700 \text{ W/m}^2$ . Let us take as average value

$q = 700 \text{ W/m}^2$ , 8 hours of the solar radiation per day and 300 unclouded days per year.  
Then the  $1 \text{ m}^2$  of Earth surface will receive energy in one day

$$E = 700 \times 8 \times 60 \times 60 \approx 20 \cdot 10^6 \text{ J/m}^2/\text{day} \text{ or } E_y \approx 6 \cdot 10^9 \text{ J/m}^2/\text{year}. \quad (1)$$

For heating 1 kg water from  $20^\circ\text{C}$  to  $100^\circ\text{C}$  and its evaporation it is necessary energy (heat)

$$Q = c_p \Delta T + r = 4.18 \cdot 80 + 2260 = 2595 \text{ kJ/kg}, \quad (2)$$

where  $c_p = 4.18 \text{ kJ/kg/K}$  is thermal capacity of water;  $\Delta T$  is change of temperature, K;  $r = 2260 \text{ kJ/kg}$  is vapor capacity of water.

The theoretically  $1 \text{ m}^2$  of Earth surface can evaporate in solar day about

$$m = \frac{E}{Q} = \frac{2 \cdot 10^7}{2.595 \cdot 10^6} = 7.7 \text{ kg/m}^2/\text{day} \text{ or } m_y = 2.3 \text{ ton/m}^2/\text{year}. \quad (3)$$

That means:

- 1) the area  $100 \times 100 \text{ m}$  will produce  $77 \text{ m}^3/\text{day}$  or  $23,100 \text{ m}^3/\text{year}$ ;
- 2) the area  $1 \times 1 \text{ km}$  will produce  $7700 \text{ m}^3/\text{day}$  or  $2.3 \times 10^6 \text{ m}^3/\text{year}$  and
- 3) the area  $10 \times 10 \text{ km}$  will produce  $770,000 \text{ m}^3/\text{day}$  or  $230 \times 10^6 \text{ m}^3/\text{year}$  (That is productivity of a big desalination plant). If one person, on the average, requires 10 liter per day, that is enough for 0, 64 million people, or for irrigation 23,000 hectors ground (1 hector =  $100 \times 100 \text{ m}$  of area).

We must add to here the rain fresh water which also is accumulated by the sea installation. The average annually world rain is about  $1 \text{ m}^3/\text{m}^2/\text{year}$ . That means from 0 to 43% additional fresh water will be produced a sea installation.

**2. Amount of water in atmosphere.** The amount of water in Earth's atmosphere depends entirely upon temperature and humidity. For relative humidity 100%, the maximum partial pressure of water vapor is shown in Table 1.

**Table 1.** Maximum partial pressure of water vapor in atmosphere for given air temperature

$t, \text{C}$	-10	0	10	20	30	40	50	60	70	80	90	100
$p, \text{kPa}$	0.287	0.611	1.22	2.33	4.27	7.33	12.3	19.9	30.9	49.7	70.1	101

The amount of water in  $1 \text{ m}^3$  of air may be computed by equation

$$m_w = 0.00625 [p(t_2)h - p(t_1)], \quad (4)$$

where  $m_w$  is mass of water, kg in  $1 \text{ m}^3$  of air;  $p(t)$  is vapor (steam) pressure from Table 1, relative  $h = 0 \div 1$  is relative humidity. The computation of equation (4) is presented in Fig.7. Typical relative humidity of atmosphere air is 0.5 - 1.

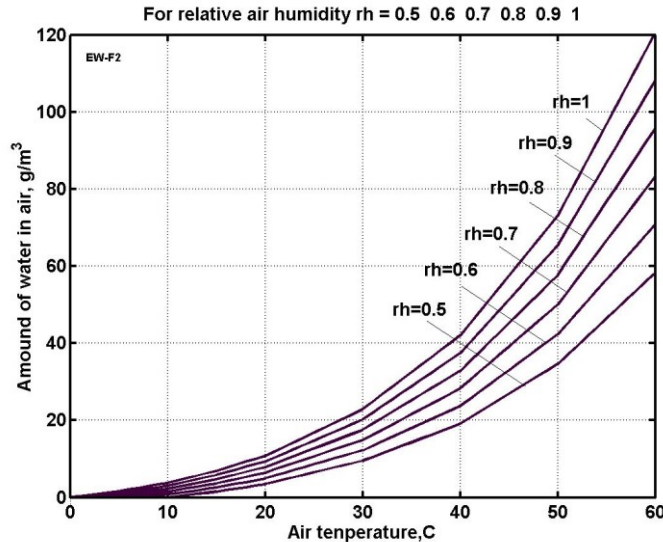
**3. Heat transfer from damp (humid) air to sea water.** Let us assume that the temperature in upper solar tubes  $75^\circ\text{C}$ , the sea water is  $25^\circ\text{C}$ . The average change of temperature is  $\Delta T = 0.5(75 - 25) = 25^\circ\text{C}$ .

The average transfer of heat flow from air to water is (tubes from thin film):

$$q \approx \lambda \Delta T = 100 \times 25 = 2.5 \text{ kW/m}^2. \quad (5)$$

Here  $\lambda = 100 \text{ W/m}^2/\text{K}$  is coefficient of heat transfer from air to water. The value  $2.5 \text{ kW/m}^2$  is more than solar heat flow  $= 1 \text{ kW/m}^2$ . That means the water will cool down the wet air into low tubes.

In our construction the air moved by sea waves. If air moves by ventilator, the computation show the requested energy is very small.



**Fig. 7.** Amount of water in  $1 \text{ m}^3$  of air versus air temperature and relative humidity (rh).  $t_l = 0 \text{ }^\circ\text{C}$ .

**4. Cost estimation. Cost of installation.** Assume the film used for tubes has thickness  $\delta = 0.07 \text{ mm}$ . Then volume of two tubes film having area  $S = 1 \text{ m}^2$  is  $V = 2\pi\delta S = 2 \cdot 3.14 \cdot 7 \cdot 10^{-5} = 4.4 \times 10^{-4} \text{ m}^3$ . If the specific density of film is  $\gamma = 1500 \text{ kg/m}^3$ , the mass of  $1 \text{ m}^2$  film is  $m = 0.66 \text{ kg/m}^2$ . If cost  $1 \text{ kg}$  film is  $\$3/\text{kg}$ , the cost of  $1 \text{ m}^2$  of distiller is  $\$2/\text{m}^2$ . The cost of area  $100 \times 100 \text{ m}$  is  $\$20\text{K}$ , the cost of  $1 \times 1 \text{ km}$  is  $\$2\text{M}$ , and the cost of a sea still  $10 \times 10 \text{ km}$  which has a freshwater productivity of about  $270 \text{ million m}^3$  a year (about five large reverse osmosis plants equivalent) is about  $\$200 \text{ million}$  of film, plus about  $\$250 \text{ million}$  of engineering and construction, the total about  $\$450 \text{ million}$ . If water is costs  $50 \text{ cents USA per m}^3$ , then payback impressively occurs in less than  $3.5 \text{ years}$ .

## Conclusion

The Solar Desalination System is the most advanced and efficient desalination system to date. The Solar Desalination System is (1) inexpensive, (2) does not require the expensive coastal land surface since located on sea, (3) does not require energy except for pumping the fresh water to customers and (4) needs minimal amount of service workers. Moreover, the minimal production costs qualify our system as by far the least expensive fresh water production method. In addition, the preassembled kits may be conveniently stored in conventional storehouse and may be easily moved (transported, delivered) to any place. Related works are in references [Bolonkin, 2002-2007], [Cathcart, 2006a,b], [Encyclopedia, 1996, 2000, 2001], [Krinker, 2009], [Wikipedia].

## References

(The reader may find some of these articles at the web page: <http://Bolonkin.narod.ru/p65.htm> , <http://arxiv.org> , <http://www.scribd.com> search "Bolonkin", in the book "Non-Rocket Space Launch and Flight", Elsevier, London, 2006, 488 pgs., in book "New Concepts, Ideas, Innovations in Aerospace, Technology and Human Science", NOVA, 2007, 502 pgs., and in book "Macro-Projects: Environment and Technology, NOVA, 2008, 536 pgs.)



- Bolonkin, A.A., (2002), “Optimal Inflatable Space Towers of High Height”. COSPAR-02 C1.1-0035-02, *34th Scientific Assembly of the Committee on Space Research (COSPAR)*, The World Space Congress – 2002, 10–19 Oct 2002, Houston, Texas, USA. <http://Bolonkin.narod.ru/p65.htm>
- Bolonkin, A.A., (2003), “Optimal Inflatable Space Towers with 3-100 km Height”, *JBIS*, Vol. 56, No 3/4, pp. 87–97, 2003. <http://Bolonkin.narod.ru/p65.htm>
- Bolonkin A.A.,(2004a), “Kinetic Space Towers and Launchers”, *JBIS*, Vol. 57, No 1/2, pp. 33–39, 2004. <http://Bolonkin.narod.ru/p65.htm>
- Bolonkin A.A., (2004b), Utilization of Wind Energy at High Altitude, AIAA-2004-5705, AIAA-2004-5756, *International Energy Conversion Engineering Conference at Providence.*, RI, Aug.16-19. 2004. USA. <http://arxiv.org/ftp/physics/papers/0701/0701114.pdf> .
- Bolonkin A.A., (2006a), “Extraction of Freshwater and Energy from Atmosphere ”, <http://arxiv.org/ftp/arxiv/papers/0704/0704.2571.pdf> .
- Bolonkin A., Cathcart R., (2006b). A Low-Cost Natural Gas/Freshwater Aerial Pipeline. <http://arxiv.org/ftp/physics/papers/0701/0701061.pdf>
- Bolonkin A.A., (2006c) Cheap Textile Dam Protection of Seaport Cities against Hurricane Storm Surge Waves, Tsunamis, and Other Weather-Related Floods. <http://arxiv.org/ftp/physics/papers/0701/0701059.pdf>
- Bolonkin A.A., (2006d) Non-Rocket Space Launch and Flight, Elsevier, 2006, 488 ps. <http://www.scribd.com/doc/24056182>
- Bolonkin A., Cathcart R., (2006e). The Java-Sumatra Aerial Mega-Tramway, <http://arxiv.org/ftp/physics/papers/0701/0701099.pdf>
- Bolonkin A., Cathcart R., (2006f). Inflatable Evergreen Polar Zone Dome (EPZD) Settlements. <http://arxiv.org/ftp/physics/papers/0701/0701098.pdf>
- Bolonkin, A.A. and R.B. Cathcart, (2006g) “A Cable Space Transportation System at the Earth’s Poles to Support Exploitation of the Moon”, *Journal of the British Interplanetary Society* 59: 375-380. <http://Bolonkin.narod.ru/p65.htm>
- Bolonkin A., (2006h). Control of Regional and Global Weather. <http://arxiv.org/ftp/physics/papers/0701/0701097.pdf>
- Bolonkin A., Cathcart R., (2006i). Antarctica: A Southern Hemisphere Windpower Station? <http://arxiv.org/ftp/physics/papers/0701/0701055.pdf>
- Bolonkin, A.A. and R.B. Cathcart (2006j), “Inflatable ‘Evergreen’ dome settlements for Earth’s Polar Regions”, *Clean Technologies and Environmental Policy* DOI 10.1007/s10098-006-0073-4 <http://Bolonkin.narod.ru/p65.htm>.
- Bolonkin A.A., (2006k). AB Method of Irrigation without Water (Closed-loop water cycle) <http://arxiv.org/ftp/arxiv/papers/0712/0712.3935.pdf>
- Bolonkin A.A., (2006l), Optimal Solid Space Tower, AIAA-2006-7717. *ATIO Conference*, 25-27 Sept. 2006, Wichita, Kansas, USA. <http://arxiv.org/ftp/physics/papers/0701/0701093.pdf>
- Bolonkin A.A., (2007). Cheap Artificial AB-Mountains, Extraction of Water and Energy from Atmosphere and Change of Regional Climate. <http://arxiv.org/ftp/arxiv/papers/0801/0801.4820.pdf>
- Cathcart R., Bolonkin A., (2006a), The Golden Gate Textile Barrier: Preserving California Bay of San Francisco from a Rising North Pacific Ocean. <http://arxiv.org/ftp/physics/papers/0702/0702030.pdf>

Cathcart R., Bolonkin A., (2006b), Ocean Terracing,  
<http://arxiv.org/ftp/physics/papers/0701/0701100.pdf>

Book (2006): *Macro-Engineering - A challenge for the future*. Collection of articles. Eds. V. Badescu, R. Cathcart and R. Schuiling, Springer, (2006). (Collection contains Bolonkin's articles: Space Towers; Cable Anti-Gravitator, Electrostatic Levitation and Artificial Gravity).

<http://www.scribd.com/doc/24057930>

*Encyclopedia of Desalination and Water and Water Resources*, (2000). Springer.

*Encyclopedia of Earth - Surface water management*, (2001). Springer.

Gleick, Peter; et al. (1996). *Encyclopedia of Climate and Weather*. Oxford University Press.

Krinker M, (2009). Review of Space Towers. <http://www.scribd.com/doc/26270139>,

<http://arxiv.org/ftp/arxiv/papers/1002/1002.2405.pdf>

*Wikipedia*. Some background material in this article is gathered from Wikipedia under the Creative Commons license. <http://wikipedia.org>.



## Chapter 4B

# High Altitude Long Distance Cheap Aerial Antenna

### Abstract

Current cell telephone network emplacements are very expensive. Companies pay large sums for nets of towers, masts, territory, rent roofs of high buildings, to emplace many complex types of equipment. The author offers a new tethered antenna located at high altitude (1 – 12 km), which serves a gigantic territory (radius 100-400 km). New antenna is cheap, does not require a large footprint of territory, is mobile and can be installed in 30 minutes. This antenna may be also useful in emergency and military situations.

**Key words:** high altitude antenna, cheap antenna, long distance antenna.

### Introduction

#### Current Antennas

**Radio and TV Antenna.** An antenna (or aerial) is a transducer designed to transmit or receive electromagnetic waves. In other words, antennas convert electromagnetic waves into electrical currents and vice versa. Antennas are used in systems such as radio and television broadcasting, point-to-point radio communication, wireless LAN, radar, and space exploration. Antennas are most commonly employed in air or outer space, but can also be operated under water or even through soil and rock at certain frequencies for short distances.

Physically, an antenna is an arrangement of conductors that generate a radiating electromagnetic field in response to an applied alternating voltage and the associated alternating electric current, or can be placed in an electromagnetic field so that the field will induce an alternating current in the antenna and a voltage between its terminals.

A common antenna is a vertical rod a quarter of a wavelength long. Such antennas are simple in construction, usually inexpensive, and both radiate in and receive from all horizontal directions (omnidirectional). One limitation of this antenna is that it does not radiate or receive in the direction in which the rod points. This region is called the antenna blind cone or null.

There are two fundamental types of antenna directional patterns, which, with reference to a specific three dimensional (usually horizontal or vertical) plane are either:

1. Omni-directional (radiates equally in all directions), such as a vertical rod or
2. Directional (radiates more in one direction than in the other).

Typically, antennas are designed to operate in a relatively narrow frequency range. The design criteria for receiving and transmitting antennas differ slightly, but generally an antenna can receive and transmit equally well. This property is called reciprocity.

**Cell site.** A cell site is a term used primarily in North America for a site where antennas and electronic communications equipment are placed on a radio mast or tower to create a cell in a network. A cell site is composed of a tower or other elevated structure for mounting antennas, and one or more sets of transmitter/receivers transceivers, digital signal processors, control electronics, a GPS receiver for timing (for CDMA2000 or IS-95 systems), regular and backup electrical power sources, and sheltering.

A synonym for "cell site" is "cell tower", although many cell site antennas are mounted on buildings rather than as towers. In GSM networks, the technically correct term is Base Transceiver Station (BTS), and colloquial British English synonyms are "mobile phone mast" or "base station". The term "base station site" might better reflect the increasing co-location of multiple mobile operators, and therefore multiple base stations, at a single site. Depending on an operator's technology, even a site hosting just a single mobile operator may house multiple base stations, each to serve a different air interface technology (CDMA or [GSM](#), for example). Preserved treescapes can often hide cell towers inside an artificial tree or preserved tree. These installations are generally referred to as concealed cell sites or stealth cell sites.



**Fig.1a** (left) Cell tower in Morrisville, North Carolina.

**Fig.2a** (right) Cell site tower in the [Philippines](#).

The working range of a cell site - the range within which mobile devices can connect to it reliably is not a fixed figure. It will depend on a number of factors, including

- The frequency of signal in use (i.e. the underlying technology).
- The transmitter's rated power.
- The transmitter's size.
- The array setup of panels may cause the transmitter to be directional or omni-directional.
- It may also be limited by local geographical or regulatory factors and weather conditions.

Generally, in areas where there are enough cell sites to cover a wide area, the range of each one will be set to:

- Ensure there is enough overlap for "handover" to/from other sites (moving the signal for a mobile device from one cell site to another, for those technologies that can handle it - e.g. making a GSM phone call while in a car or train).
- Ensure that the overlap area is not too large, to minimize interference problems with other sites.

In practice, cell sites are grouped in areas of high population density, with the most potential users. Cell phone traffic through a single cell mast is limited by the mast's capacity; there is a finite number of calls that a mast can handle at once. This limitation is another factor affecting the spacing of cell mast sites. In suburban areas, masts are commonly spaced 1-2 miles apart and in dense urban areas, masts may be as close as  $\frac{1}{4}$ - $\frac{1}{2}$  mile apart. Cell masts always reserve part of their available bandwidth for emergency calls.

The *maximum* range of a mast (where it is not limited by interference with other masts nearby) depends on the same circumstances. Some technologies, such as GSM, have a fixed maximum range of 40km (25 miles), which is imposed by technical limitations. CDMA and iDEN have no built-in limit, but the limiting factor is really the ability of a low-powered personal cell phone to transmit back to the mast. As a rough guide, based on a tall mast and flat terrain, it is possible to get between 50 to 70 km (30-45 miles). When the terrain is hilly, the maximum distance can vary from as little as 5 kilometres (3.1 mi) to 8 kilometres (5.0 mi) due to encroachment of intermediate objects into the wide center fresnel zone of the signal. Depending on terrain and other circumstances, a GSM Tower can replace between 2 and 50 miles of cabling for fixed wireless networks.

A cellphone may not work at times, because it is too far from a mast, but it may also not work because the phone is in a location where there is interference to the cell phone signal from thick building walls, hills or other structures. The signals do not need a clear line of sight but the more interference will degrade or eliminate reception. Too many people may be trying to use the cell mast at the same time, e.g. a traffic jam or a sports event, then there will be a signal on the phone display but it is blocked from starting a new connection. The other limiting factor for cell phones is the ability of the cell phone to send a signal from its low powered battery to the mast. Some cellphones perform better than others under low power or low battery, typically due to the ability to send a good signal from the phone to the mast.

**Cell Telephones.** A mobile phone or mobile (also called cellphone and handphone, as well as cell phone, wireless phone, cellular phone, cell, cellular telephone, mobile telephone or cell telephone) is a long-range, electronic device used for mobile voice or data communication over a network of specialized base stations known as cell sites. In addition to the standard voice function of a mobile phone, telephone, current mobile phones may support many additional services, and accessories, such as SMS for text messaging, email, packet switching for access to the Internet, gaming, Bluetooth, infrared, camera with video recorder and MMS for sending and receiving photos and video, MP3 player, radio and GPS. Most current mobile phones connect to a cellular network consisting of switching points and base stations (cell sites) owned by a mobile network operator (the exception is satellite phones, which are mobile but not cellular).

The International Telecommunication Union estimated that mobile cellular subscriptions worldwide would reach approximately 4.1 billion by the end of 2008. Mobile phones have gained increased importance in the sector of Information and communication technologies for development in the 2000s.

The largest categories of mobile services are music, picture downloads, videogaming, adult entertainment, gambling, video/TV.



A **cellular network** is a radio network made up of a number of radio cells (or just cells) each served by at least one fixed-location transceiver known as a cell site or base station. These cells cover different land areas to provide radio coverage over a wider area than the area of one cell, so that a variable number of portable transceivers can be used in any one cell and moved through more than one cell during transmission.

The increased capacity in a cellular network, compared with a network with a single transmitter, comes from the fact that the same radio frequency can be reused in a different area for a completely different transmission. If there is a single plain transmitter, only one transmission can be used on any given frequency.

**Radio Masts and Towers.** Radio masts and towers are, typically, tall structures designed to support antennas (also known as aerials in the UK) for telecommunications and broadcasting, including television. They are among the tallest man-made structures. Similar structures include electricity pylons and towers for wind turbines. Masts are sometimes named after the broadcasting organisations that use them, or after a nearby city or town. The Warsaw Radio Mast was the world's tallest supported structure on land, but it collapsed in 1991, leaving the KVLV/KTHI-TV mast as the tallest.

The terms "mast" and "tower" are often used interchangeably. However, in structural engineering terms, a tower is a self-supporting or cantilevered structure, while a mast is held up by stays or guys.

Masts tend to be cheaper to build but require an extended area surrounding them to accommodate the stay blocks. Towers are more commonly used in cities where land is in short supply.



**Fig.3a** (left). First modern TV Tower in Stuttgart.

**Fig.4a** (middle) Sapporo TV tower, at Odori park.

**Fig.5a** (right). Some mobile phone masts are disguised as trees or flagpoles to reduce their visual impact. By contrast, this pink and blue Barber's pole style mast in Durham, England, stands out as a feature in the street.

In some cases, it is possible to install transmitting antennas on the roofs of tall buildings. In North America, for instance, there are transmitting antennas on the Empire State Building, the Sears Tower, and formerly on the World Trade Center towers. When the buildings collapsed, several local TV and radio stations were knocked off the air until backup transmitters could be

put into service. Such facilities also exist in Europe, particularly for portable radio services and low-power FM radio stations.

Many people view bare [cellphone](#) towers as ugly and an intrusion into their neighbourhoods. Even though people increasingly depend upon cellular communications, they are opposed to the bare towers spoiling otherwise scenic views. Many companies offer to 'hide' cellphone towers as trees, church towers, flag poles, water tanks and other features.<sup>[2]</sup> There are many providers that offer these services as part of the normal tower installation and maintenance service. These are generally called "stealth towers" or "stealth installations".

- The cost of a mast or tower is roughly proportional to the square of its height.
- A guyed mast is cheaper to build than a self-supporting tower of equal height.
- A guyed mast needs additional land to accommodate the guys, and is thus best suited to rural locations where land is relatively cheap. An unguyed tower will fit into a much smaller plot.
- A steel lattice tower is cheaper to build than a concrete tower of equal height.
- Two small towers may be less intrusive, visually, than one big one, especially if they look identical.
- Towers look less ugly if they and the antennas mounted on them appear symmetrical. Concrete towers can be built with aesthetic design - and they are, especially in Continental Europe. They are sometimes built in prominent places and include observation decks or restaurants.

[Tall structures in excess of certain legislated heights are often equipped with aircraft warning lamps, usually red, to warn pilots of the structure's existence.

**Table 1a. Structures (past or present) taller than 600 m (1,969 ft)**

Name	Pinnacle height		Year	Structural type	Main use	Country	Town	Remarks
Burj Dubai	2,684 feet	818 m	2009	Skyscraper	Office, hotel, residential	United Arab Emirates	Dubai	Topped-out on 17 January 2009
<i>Warsaw Radio Mast</i>	2,121 feet	646.4 m	1974	Guyed mast	LF-transmission	Poland	<a href="#">Gabin-Konstantynów, Masovian Voivodeship</a>	insulated; collapsed on August 8, 1991 during guy wire exchange
KVLY/KTHI TV Mast	2,063 feet	628.8 m	1963	Guyed mast	UHF/VHF-transmission	U.S.	Blanchard, North Dakota	World's tallest mast
KXJB-TV mast	2,060 feet	627.8 m	1998	Guyed mast	UHF/VHF-transmission	U.S.	Galesburg, North Dakota	rebuilt after collapses on February 14, 1968 and on April 6, 1997



KXTV/KOVR Tower	2,049 feet	624.5 m	2000	Guyed mast	UHF/VHF-transmission	U.S.	Walnut Grove, California	Tallest structure in California
-----------------	------------	---------	------	------------	----------------------	------	--------------------------	---------------------------------

### Cost of Radio and TV towers and cell towers.

The Sears Tower in Chicago, a working commercial skyscraper, has a height to the tip of its highest antenna is 1,730 feet (527.3 m) above street level or 2,325 feet (708 m) above sea level, its roof is 1,450 feet and 7 inches (442.1 m) above street level or 2,046 feet (623 m) above sea level and cost \$175 millions (price in 1973). It is merely here representative of the class of buildings which serve as the foundation for comm towers.

Most small dedicated cell towers cost between \$75,000 and \$200,000 to build with the average being around \$100,000. The lease of the space on the tower would net between \$18,000 to \$30,000 per year depending upon the location. The average tower can accommodate four users or up to \$120,000 PER YEAR in income. Assuming that the tower costs \$10,000 a year to operate, that is a net income of \$110,000 per year off of a structure that costs up to \$200,000 to build.

Contrast that with the municipality leasing space to a wireless carrier to build a tower. If the municipality were to lease the ground space, it would receive somewhere between \$12,000- \$24,000 per year depending upon the location.

### Some information about wind energy

Wind speed strongly depends upon altitude. Low altitude wind ( $H = 10$  m) has the standard average speed  $V = 6$  m/s. High altitude wind is powerful and that has another important advantage, it is stable and constant. This is true practically everywhere.

Wind in the troposphere and stratosphere are powerful and permanent. For example, at an altitude of 5 km, the average wind speed is about 20 m/s, at an altitude 10 -12 km the wind may reach 40 m/s (at latitude of about 20-35°N).

There are permanent jet streams at high altitude. For example, at  $H = 12-13$  km and about 25°N latitude. The average wind speed at its core is about 148 km/h (41 m/s). The most intensive portion, with a maximum speed 185 km/h (51 m/s) latitude 22°, and 151 km/h (42 m/s) at latitude 35° in North America. On a given winter day, speeds in the jet core may exceed 370 km/h (103 m/s) for a distance of several hundred miles along the direction of the wind. Lateral wind shears in the direction normal to the jet stream may be 185 km/h per 556 km to right and 185 km/h per 185 km to the left.

A wind speed of  $V = 40$  m/s at an altitude  $H = 13$  km provides ~64 times more energy than surface wind speeds of 6 m/s at an altitude of 10 m.

This is a gigantic renewable and free energy source. (See reference [17]: *Science and Technology*, v.2, p.265). Author of [18] developed the tethered high altitude flight apparatus, which allows us to use this gigantic energy. That platform may be useful for a high altitude antenna.

### Suggested Innovation

Current cell telephone network coverage is very expensive. The region of efficiency is significantly dependant upon the altitude of the transmission antenna. Results of computations (radius of efficiency via antenna altitude) are presented in fig.1. As you see only four 10 km high antennas can serve the

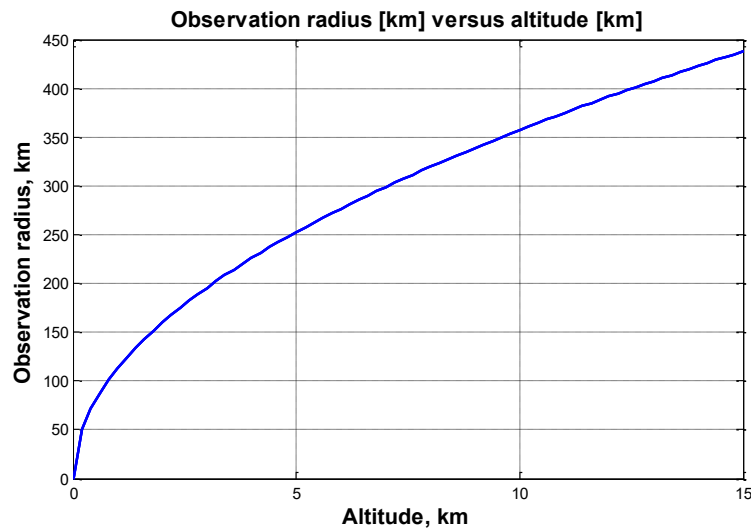
territory 1.44 million square km. ( $0.56 \text{ ml}^2$ ). For comparison in Table 1 it is given the territory (area) and population of some countries. All noted countries can be covered by 4 – 8 of 10-km high altitude cheap antennas.

Companies pay large money for networks of towers, masts, territory, rents of roofs of high buildings, many complex types of equipment which must be duplicated many more times than necessary than the alternate scenario where fewer, higher bases for the equipment would enable doing more coverage with less capital.

A common idea toward this goal is to essay to lift an antenna by balloon or kite at altitude. But attempts to use balloons were not successful.

Conventional balloons work well in windless weather, but small wind forces can force it to ground. The kite cannot lift at high altitude, is not stable (most people have seen a sudden plunge of a child's kite in strong wind), cannot work in turbulent or windless weather.

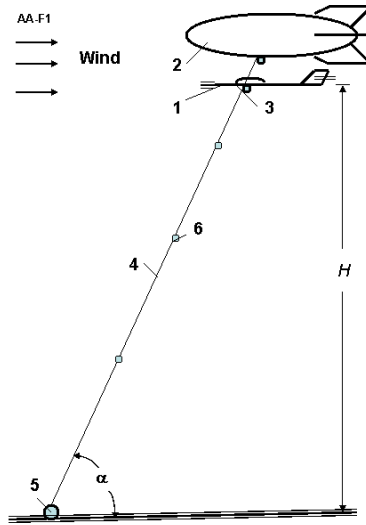
Authors offer a new combination antenna installation which contain a new high efficiency flight apparatus and form of air balloon which are absent these defects and can stably work in wide ranges of altitude (up to 15 km) and wind speeds (0 – 40 m/s). The new tethered antenna locates at high altitude (1 – 15 km), which serves a gigantic territory (radius of coverage is about 100 - 400 km). New antenna is cheap, requires only a small base site, is, mobile and can be installed in 30 minutes. This antenna may be also useful in emergency and military situations (fig.2).



**Fig.1.** Radius of line of sight vs. altitude of antenna.

**Table 1.** Area and Population some countries

Country	Area, mln $\text{ml}^2$	Population, mln	Country	Area, mln $\text{ml}^2$	Population, mln
France	0.21	50	Italy	1.16	54
England, UK	0.5	46	Japan	1.43	105
Gemany	1.38	78	New York	0.49	18



**Fig.2.** High altitude aerial antenna. *Notations:* 1 – special high lift air apparatus; 2 – small dirigible (air balloon) for supporting the aerial antenna at high altitude; 3 – high altitude antenna; 4 – cable; 5 – winch; 6 – illuminations and sensor of wind intensity.

The authors have invented a flight device, which can produce significant lift force in wind and non-wind weather, and support antenna at high altitude. The installation cost and maintenance of new installations are cheaper by tens (hundred) of times than conventional Radio-TV towers or cell telephone networks.

## Computation

Below are some computation from theory developed by authors.

**1. Radius efficiency.** The distance  $L$  which can be viewed of the Earth from a high altitude (antenna) is given by equation

$$L = R_e \arccos \frac{R_e}{R_e + H}, \quad (1)$$

where  $R_e = 6378$  km is the Earth radius,  $H$  is the antenna's altitude. This distance approximately equals

$$L \approx \sqrt{2R_e H + H^2}. \quad (2)$$

The result of computation is presented in fig.1.

**2. Lift Force.** Lift force of flight apparatus may be computed by equation

$$L = C_L \frac{\rho V^2}{2} S, \quad (3)$$

where  $L$  - lift force [N];  $C_L$  - lift coefficient,  $C_L = 0 - 2$ ;  $\rho$  - air density, if altitude  $H$  closed to 0  $\rho = 1.225$  kg/m<sup>3</sup>;  $V$  - wind speed [m/sec];  $S$  - wing area [m<sup>2</sup>].

When designer know load, safe wind speed, altitude, and fiber stress, he can estimate the necessary wing area.

**3. Cable (Fiber) Mass.** Cable mass can be computed by equation:

$$M = l \frac{\gamma}{\sigma} F, \quad (4)$$

where  $M$  - mass of cable (fiber) [kg];  $l$  - length of cable [m];  $\gamma$  - cable density [kg/m<sup>3</sup>];  $\sigma$  - cable stress [kg/m<sup>2</sup>];  $F$  - tensile force [N]. The mass of cable is small.

**4. Diameter of the Cable.** Diameter of cable (fiber),  $d$ , may be computed by equation

$$d = 2 \sqrt{\frac{F}{\pi \sigma}}. \quad (5)$$

**5. Drag of the Cable.** Drag of main cable (fiber) can be calculated by equation

$$D_{f,1} = C_{D,f1} \frac{\rho V^2}{2} \frac{\pi}{4} l d, \quad (6)$$

where  $D_{f,1}$  - drag of main cable in [N];  $C_{D,f1}$  - drag coefficient;  $l$  - length of main cable [m].

**6. Flight Apparatus Cable Angle.** The flight apparatus cable angle to horizon without cable drag,  $\varphi_1$ , and with cable drag,  $\varphi_2$ , may be calculate by equations

$$\tan \varphi_1 = \frac{C_L}{C_D} = \frac{C_L}{C_{D_0} + C_L^2 / \pi \lambda}, \quad \tan \varphi_2 = \frac{C_L}{C_D + 0.5 \frac{S_f}{S} C_{D,f1}}, \quad (7-8)$$

where  $C_{D_0}$  - kite drag when  $C_L=0$ ;  $\lambda$  - wing aspect ratio,  $S_f$  - drag fiber area,  $S_f = Hd$  [m<sup>2</sup>];  $S$  - wing area [m<sup>2</sup>];  $C_{D,f1}$  - cable drag coefficient.

## Conclusion

Current cell telephone networks are very capital intensive. Companies pay large sums for networks of towers, masts, territory, rent roofs of high buildings, many copies of complex equipment. Authors offer a new tethered antenna located at high altitude (1 – 15 km), which serves a gigantic territory (radius 100 - 400 km). New antenna is cheaper, with a small site required for installation, mobile and can be installed in 30 minutes. This antenna may be also useful in emergency and military situations.

Cost of the offered high altitude antenna of height 5 km (radius of coverage  $R=250$  km) is about \$1-3 million. The antenna having height up to 12 km (radius of coverage  $R=400$  km) costs about \$2-6 millions.

More detailed information about high altitude and space towers the interested reader may find in [1]-[19].

## Acknowledgement

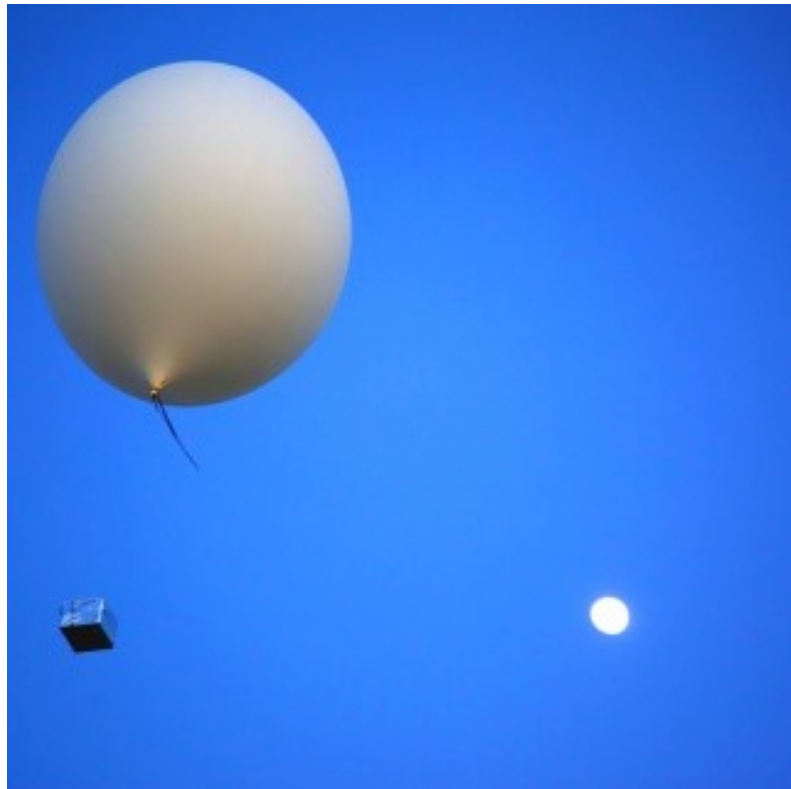
The author wishes to acknowledge Joseph Friedlander (of Shave Sharon, Israel) for correcting the English and offering useful advice and suggestions.

## References

Many works noted below the reader can find author's site <<http://bolonkin.narod.ru/p65.htm>>, on site Cornell University <<http://arxiv.org/>>, <<http://scribd.com>> search "Bolonkin", and in Conferences 2002-2006 (see, for example, Conferences AIAA, <<http://aiaa.org>>, search "Bolonkin")

1. Bolonkin A.A. (2006), Optimal Solid Space Tower, Paper AIAA-2006-7717, ATIO Conference, 25-27 Sept., 2006, Wichita, Kansas, USA, <http://arxiv.org/ftp/physics/papers/0701/0701093.pdf>. See also paper AIAA-2006-4235 by A. Bolonkin, <http://aiaa.org> search "Bolonkin"

2. Bolonkin A.A. (2007), Optimal Rigid Space Tower, Paper AIAA-2007-367, 45th Aerospace Science Meeting, Reno, Nevada, 8-11 Jan.,2007, USA. <http://bolonkin.narod.ru/p65.htm> .
3. Bolonkin A.A., "New Concepts, Ideas and Innovation in Aerospace", NOVA, 2008, Ch.9, "Optimal Solid Space Tower", pp.161-172. <http://www.scribd.com/doc/24057071> ,
4. Bolonkin A.A.,(2002), "Optimal Inflatable Space Towers of High Height", COSPAR-02 C1. 10035-02, 34th Scientific Assembly of the Committee on Space Research (COSPAR). The World Space Congress - 2002, 10 -19 Oct. 2002, Houston, Texas, USA. <http://bolonkin.narod.ru/p65.htm>
5. Bolonkin A.A., *Optimal Inflatable Space Towers with 3 -100 km Height*", JBIS, Vol.56,No.3/4, pp.87-97, 2003. <http://bolonkin.narod.ru/p65.htm> .
6. Book "Non-Rocket Space Launch and Flight", by A.Bolonkin, Elsevier. 2006, Ch.4 "Optimal Inflatable Space Towers", pp.83-106; <http://www.scribd.com/doc/24056182> .
7. Bolonkin A.A., "Macro-Engineering: Environment and Technology", Ch.1A "Artificial Mountains", pp. 299-334, NOVA, 2008. <http://www.scribd.com/doc/24057930>
8. Book "Non-Rocket Space Launch and Flight", by A.Bolonkin, Elsevier. 2006, Ch.9 "Kinetic Anti-Gravotator", pp. 165-186; Main idea of this Chapter was presented as papers COSPAR-02, C1.1-0035-02 and IAC-02-IAA.1.3.03, 53<sup>rd</sup> International Astronautical Congress. The World Space Congress-2002, 10-19 October 2002, Houston, TX, USA, and the full manuscript was accepted as AIAA-2005-4504, 41<sup>st</sup> Propulsion Conference, 10-12 July 2005, Tucson, AZ, USA. <http://www.scribd.com/doc/24056182>
9. Book "Non-Rocket Space Launch and Flight", by A.Bolonkin, Elsevier. 2006, Ch.5 "Kinetic Space Tower", pp. 107-124. <http://www.scribd.com/doc/24056182>
10. "Transport System for Delivery Tourists at Altitude 140 km", manuscript was presented as Bolonkin's paper IAC-02-IAA.1.3.03 at the World Space Congress-2002, 10-19 October, Houston, TX, USA. <http://bolonkin.narod.ru/p65.htm>
11. Bolonkin A.A., "Centrifugal Keeper for Space Station and Satellites", JBIS, Vol.56, No. 9/10, 2003, pp. 314-327. <http://bolonkin.narod.ru/p65.htm>
12. Book "Non-Rocket Space Launch and Flight", by A.Bolonkin, Elsevier. 2006, Ch.3 "Circle Launcher and Space Keeper", pp.59-82. <http://www.scribd.com/doc/24056182>
13. Bolonkin A.A., "Optimal Electrostatic Space Tower", Presented as Paper AIAA-2007-6201 to 43<sup>rd</sup> AIAA Joint Propulsion Conference, 8-11 July 2007, Cincinnati, OH, USA. See also "Optimal Electrostatic Space Tower" in: <http://arxiv.org/ftp/arxiv/papers/0704/0704.3466.pdf> .
14. Book "New Concepts, Ideas and Innovation in Aerospace", NOVA, 2008, Ch. 11 "Optimal Electrostatic Space Tower (Mast, New Space Elevator)", pp.189-204. <http://www.scribd.com/doc/24057071>
15. Book "New Concepts, Ideas and Innovation in Aerospace", NOVA, 2008, Ch.12, pp.205-220 "AB Levitrons and Their Applications to Earth's Motionless Satellites". (About Electromagnetic Tower). <http://www.scribd.com/doc/24057071>
16. Book "Macro-Projects: Environment and Technology", NOVA, 2008, Ch.12, pp.251-270, "Electronic Tubes and Quasi-Superconductivity at Room Temperature", (about Electronic Towers). <http://www.scribd.com/doc/24057930>
17. *Science and Technology*, v.2, p.265.
18. Bolonkin A.A., Utilization of Wind Energy at High Altitude, AIAA-2004-5756, AIAA-2004-5705. International Energy Conversion Engineering Conference at Providence, RI, USA, Aug.16-19, 2004. <http://www.scribd.com/doc/24058357>
19. *Wikipedia*. Some background material in this article is gathered from Wikipedia under the Creative Commons license. <http://wikipedia.org> .



## Chapter 5B

# Suppression of Forest Fire by Helicopter without Water

### Abstract

The natural occurrences of wildfires damage nature areas, produce the hundreds of millions of dollars in losses, and considerable pollution of environment. The author suggests a very efficient method of suppression of a forest fire without water. He offers a system of simple light plates or anchor suspended from any helicopter which directs the helicopter propeller airflow against the direction of a wildfire. After some minutes the natural fuel burns away in the front of fire and the fire cannot advance.

The author developed theory and methods computations and suggests some designs of the devices for so changing the helicopter airflow direction.

-----

**Key words:** Wildfire, suppression of wildfire, suppression of forest fire by helicopter.

### Introduction

A **wildfire** is any uncontrolled fire that occurs in the countryside or wildland (wilderness). Other names such as *brush fire*, *bushfire*, *forest fire*, *grass fire*, *hill fire*, *peat fire*, *vegetation fire*, and *wildland fire* may be used to describe the same phenomenon. A wildfire differs from other fires by its extensive size; the speed at which it can spread out from its original source; its ability to change direction unexpectedly; and to jump gaps, such as roads, rivers and fire breaks. Wildfires are characterized in terms of their physical properties such as speed of propagation; the combustible material present; the effect of weather on the fire; and the cause of ignition.

Fossil records and human history contain accounts of wildfires, and wildfires occur on every continent except Antarctica and can be cyclical events. Wildfires can cause extensive damage, both to property and human life (*e.g.* Black Saturday bushfires). Along with the damage caused, they also have various beneficial effects on wilderness areas, such as plant species that are dependent on the effects of fire for growth and reproduction. However, large wildfires may have negative ecological effects.

Wildfires have a rapid *forward rate of spread* (FROS) when fueled by dense uninterrupted vegetation, particularly in wooded areas with canopies. They can escalate as fast as 10.8 kilometers per hour (6.7 mph) in forests and 22 kilometers per hour (14 mph) in grasslands. The ability of a wildfire's burning front to change direction unexpectedly and jump across fire breaks is another identifying characteristic. Intense heat and smoke can lead to disorientation and loss of appreciation of the direction of the fire. These factors make fires particularly dangerous: in 1949 the Mann Gulch fire in Montana, USA, thirteen smokejumpers died when they lost their communication links and became disorientated; the fire consumed 18 km<sup>2</sup> (4500 acres). In the Australian February 2009 Victorian bushfires, at least 173 people died and over 2,029 homes and 3,500 structures were lost when they became engulfed by wildfire.

Overall, fire types can be generally characterized by their fuel as follows:



- **Ground** fires are fed by subterranean roots, duff and other buried organic matter. This fuel type is especially susceptible to ignition due to spotting. Ground fires typically burn by smoldering, and can burn slowly for days to months, such as peat fires in Kalimantan and East Sumatra, Indonesia, a result of a riceland creation project that unintentionally drained and dried the peat.
- **Crawling** or **surface** fires are fueled by low-lying vegetation such as leaf and timber litter, debris, grass, and low-lying shrubbery. Human-ignited ground-clearing fires can spread to the Amazon rain forest, damaging ecosystems not particularly suited for heat or arid conditions.
- **Ladder** fires consume material between low-level vegetation and tree canopies, such as small trees, downed logs, and vines. Invasive plants such as Kudzu and Old World climbing fern that scale trees may also encourage ladder fires.
- **Crown, canopy, or aerial** fires devour suspended material at the canopy level, such as tall trees, vines, and mosses. The ignition of a crown fire is dependent on the density of the suspended material, canopy height, canopy continuity, and sufficient surface and ladder fires in order to reach the tree crowns.



**Fig.1.** Typical wildfire.

The four major natural causes of wildfire ignitions are lightning, volcanic eruption, sparks from rockfalls, and spontaneous combustion. The thousands of coal seam fires that are burning around the world can also flare up and ignite nearby flammable material (*e.g.* [Centrailia](#), Pennsylvania; Burning Mountain, Australia; and in China). However, many wildfires are attributed to human sources such as arson, discarded cigarettes, sparks from equipment, and power line arcs (detected by arc mapping).

Many ecosystems are suffering from too much fire, such as the chaparral in southern California and lower elevation deserts in the American Southwest.

Wildfire suppression may include a variety of tools and technologies, including throwing sand and beating fires with sticks and palm fronds in rural Thailand, using silver iodide to encourage snow fall in China, and full-scale aerial assaults by ALTUS II unmanned aerial vehicles, planes, and helicopters using drops of water and fire retardants. Complete fire suppression is no longer an expectation, but the majority of wildfires are often extinguished before they grow out of control. While more than 99% of the 10,000 new wildfires each year are contained, escaped wildfires can cause extensive damage.

Worldwide damage from wildfires is in the billions of euros annually. Wildfires in Canada and the US consume an average of 54,500 square kilometers (13,000,000 acres) per year.



**Fig.2.** A MAFFS-equipped Air National Guard C-130 Hercules drops fire retardant on wildfires in Southern California

On average, wildfires burn 4.3 million acres (17,000 km<sup>2</sup>) in the United States annually. In recent years the federal government has spent \$1 billion a year on fire suppression. 2002 was a record year for fires with major fires in Arizona, California, Colorado, and Oregon.

These crews use heavier equipment to construct firebreaks, and are the mainstay of most firefighting efforts. Other personnel are organized into fast attack teams typically consisting of 5–8 people. These fast attack teams are helicoptered into smaller fires or hard to reach areas as a preemptive strike force. They use portable pumps to douse small fires and chainsaws to construct firebreaks or helicopter landing pads if more resources are required. Hand tools are commonly used to construct firebreaks and remove fuels around the perimeter of the fire to halt its spread, including shovels, rakes, and the pulaski, a tool unique to wildland firefighting. In the eastern United States, portable leaf blowers are sometimes used. In the western United States, large fires often become extended campaigns, and temporary fire camps are constructed to provide food, showers, and rest to fire crews. These large fires are often handled by 20 person hand crews, sometimes known as hotshot crews, specially organized to travel to large fires.

Fast attack teams, such as the Boise District BLM Helitack crew, are often considered the elite of firefighting forces, as they sometimes deploy in unusual ways. If the fire is on a particularly steep hill or in a densely wooded area, they may rappel or fast-rope down from helicopters. If the fire is extremely remote, firefighters known as smokejumpers may parachute into site from fixed-wing aircraft. In addition to the aircraft used for deploying ground personnel, firefighting outfits often possess helicopters and water bombers specially equipped for use in aerial firefighting. These aircraft can douse areas that are inaccessible to ground crews and deliver greater quantities of water and/or flame retardant chemicals. Managing all of these various resources over such a large area in often very rugged terrain is extremely challenging, and often the Incident Command System is used. As such, each fire will have a designated Incident Commander who oversees and coordinates all the operations

on the fire. This Incident Commander is ultimately responsible for the safety of the firefighters and for the success of firefighting efforts.



**Fig.3.** Kern County (California) Fire Department Bell 205 dropping water on fire

**Statistics (Wikipedia 2009).** Every year, the burnt surface represents about:

- France: 211 km<sup>2</sup>, 52,140 acres, 0.04% of the territory.
- Portugal:
  - 2003 : 4,249 km<sup>2</sup>, 1.05 million acres, i.e. 4.6% of the territory; 20 deaths ;
  - 2004 : 1,205 km<sup>2</sup>, 297,836 acres, i.e. 1.3% of the territory ;
  - 2005 : 2,864 km<sup>2</sup>, 707,668 acres, i.e. 3.1% of the territory; 17 deaths;
  - 2006 : 724 km<sup>2</sup>, 178,904 acres, i.e. 0.8% of the territory; 10 deaths.
- United States: 17,400 km<sup>2</sup>, 4.3 million acres i.e. 0.18% of the territory.
- Indonesia.
  - 1982 and 1983: 36,000 km<sup>2</sup> (8.9 million acres);
  - 1997 and 1998: 97,550 km<sup>2</sup> (24.1 million acres) - from ADB;
  - 1999: 440.90 km<sup>2</sup> (108,949 acres);
  - 2002: 366.91 km<sup>2</sup> ( 90,665 acres);
  - 2005: 133.28 km<sup>2</sup> ( 32,934 acres).

Wildfires can affect climate and weather and have major impacts on regional and global pollution. Wildfire emissions contain greenhouse gases and a number of criteria pollutants which can have a substantial impact on human health and welfare. Forest fires in Indonesia in 1997 were estimated to have released between 0.81 and 2.57 gigatonnes (0.89 and 2.83 billion short tones) of CO<sub>2</sub> into the atmosphere, which is between 13 - 40% of the annual carbon dioxide emissions from burning fossil fuels. Atmospheric models suggest that these concentrations of sooty particles could increase absorption of incoming solar radiation during winter months by as much as 15% (Bolonkin 2006).

## 2. Innovations and description.

Everyone has blown out the candles on their birthday cake by an air flow from their mouth. That is the simplest method to blow out a flame. The problem is supplying enough power.

Suppression of a forest fire by air flow at first was offered by Melchor Duran (Spain). He suggested delivering powerful fans (ventilators) to the locale of a forest fire, to install them at the fire front, turn on the ventilators (whence the energy?) and to stop the fire. That method is not practical for the following reasons:

1. The fire suppression ventilator (fan) is a big, heavy, power-hungry, expensive, immobile installation.
2. It is difficult to deliver to a forest fire front where good roads are absent.
3. The unpacking and setup takes a long time and a fire can rage over a large area faster than the fan can be moved. This could endanger crews.
4. It is difficult to move even a hypothetically effective installation from a given place to another place.
5. During fire seasons, many thousands of square kilometers or miles may need constant back and forth attention.

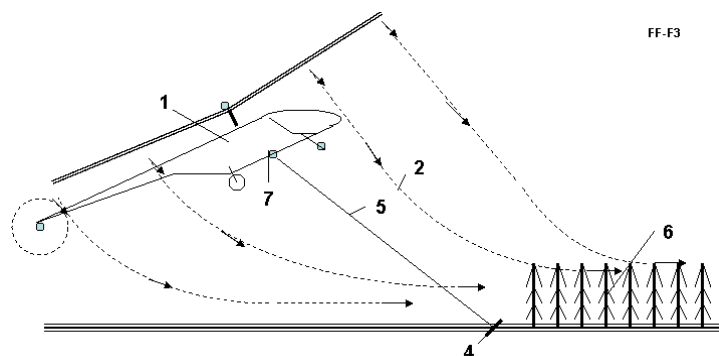
The author offers to use in place of this hypothetical movie-storm sized fan (ventilator) the conventional *helicopter* (Bolonkin 2009). Helicopter has the following advantages:

1. A helicopter is an already existing, paid for, *ready-for-action* power fan. Every major forest fire team has helicopters.
2. A helicopter has a big rotor (propeller), which produces a strong air flow (jet).
3. A helicopter has a high speed and it may be quickly delivered to fire areas and moved back and forth between ground crews preparing the cable stations at the fire fronts. This expensive asset can avoid waiting immobile while emplacements are made.
- 4 Any helicopter may be used as a fire helicopter by suspending of additional equipment.
5. The additional equipment is cheap (cables, anchor or plates).

For fire suppression we need a horizontal air jet flow against the wind direction. The helicopter produces a vertical air jet. The strong vertical jet can only increase the fire because the jet (near ground) sends the firebrands and sparks in all directions.

For producing the horizontal flow (changing the flow from vertical to horizontal direction at near of ground) the author suggest two methods. The first method is shown in fig.4, the second method is shown in fig. 5 – 6.

In the first method the helicopter has a ground anchor (hook). That joins the helicopter temporarily to the ground and gives a declination to the vertical axis of the helicopter rotor (fig.4). The ground surface helps to turn the flow in a horizontal direction. When the forest fire's fuel burns out (3 -10 minutes), the helicopter disconnects (from) the anchor (or the anchor from the ground surface) and moves to the next place the fire crews are setting up for this assistance.



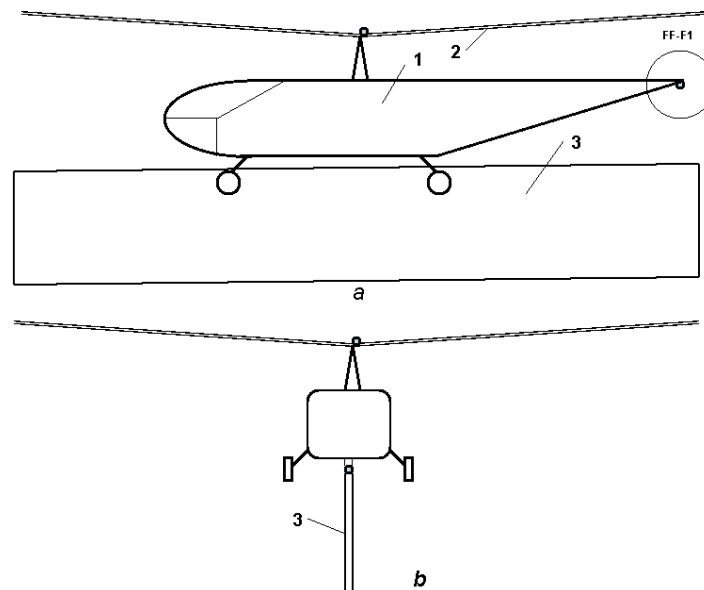
**Fig. 4.** Deflecting the helicopter air flow by anchoring. *Notations:* 1 – helicopter; 2 – air flow; 4 – anchor; 5 – connection cable; 6 – forest fire; 7 – emergency disconnection (anchor) device.

The second method is shown in fig.5. In this method the two plates (deflectors) are suspended under the helicopter.

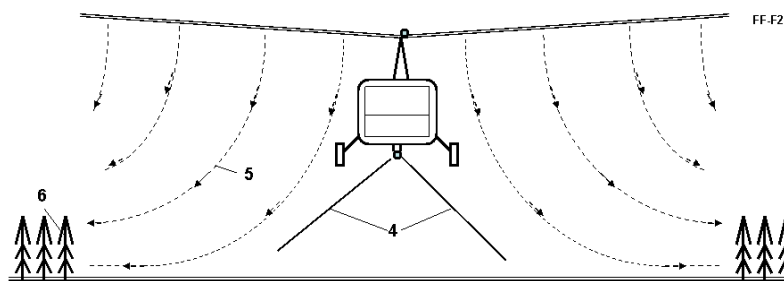
The helicopter is relocated to the fire front, opens (declines) the directed plate (fig.6) and half of the rotor flow counteracts the movement of the fire and the other half of the rotor flow blows back the frangible material that is potential fuel (dry leaves, branches, grass) far from the fire front. Different fire tactics are possible, depending on the winds on site. For example, if the wind is weak, the helicopter can slowly fly along the fire front and not allow progression of the fire front while the forest fuel loading on the forest floor will be consumed.

The helicopter can drive away the flame to places where new fuel is scarce or absent.

If the helicopter uses the cable and the hook, it can reel the cable and drive away the flame more than on a spot basis. We can install a 'perimeter cable' along the fire front and the helicopter cable can slide along this fire front 'perimeter cable'.



**Fig.5.** Fire helicopter with suspended plates. (a) – side view; (b) – front view. *Notations:* 1 – conventional helicopter; 2 – helicopter rotor (propeller); 3 – suspended plates. They are reeled up after take off of helicopter and deployed downward before landing of helicopter.



**Fig.6.** Suppression of fire. *Notations:* 4 – deflected plates; 5 – deflected air flow.

#### **Advantages of offered method:**

1. Cheapest; because it needs only anchors (hook) or simple plates (helicopters exist already in most major fire teams).

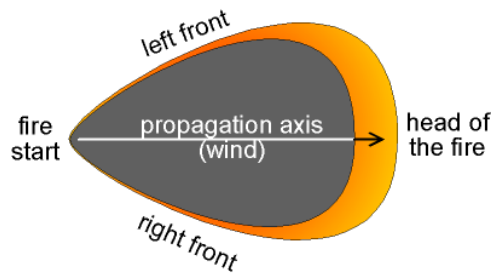


2. Quickly mobile. Helicopters will be immediately delivered to the fire.
3. Does not need water.
4. The helicopters can work continuously. It is not necessary to fly for water that may be located at the long distance and take much time.
5. One helicopter can suppress a fire in a large area.

### 3. Theory of wildfire.

**Diffusing of fire.** Diffusion of fire is shown in fig.7. Wildfires occur when the necessary elements of a fire triangle intersect: an ignition source is brought into contact with a combustible material such as vegetation, that is subjected to sufficient heat and has an adequate supply of oxygen from the ambient air. A high moisture content usually prevents ignition and slows propagation, because higher temperatures are required to evaporate any water within the material and heat the material to its fire point. Dense forests usually provide more shade, resulting in lower ambient temperatures and greater humidity. Less dense material such as grasses and leaves are easier to ignite because they contain less water than denser material such as branches and trunks. Plants continuously lose water by [evapotranspiration](#), but water loss is usually balanced by water absorbed from the soil, humidity, or rain. When this balance is not maintained, plants dry out and are therefore more flammable, often a consequence of a long, hot, dry periods.

The fire moves in the direction of wind and fire speed depends on the wind speed. Strong wind increases the probable spread and speed of fire.



**Fig.7.** Diffusion of wildfire.

#### Computation

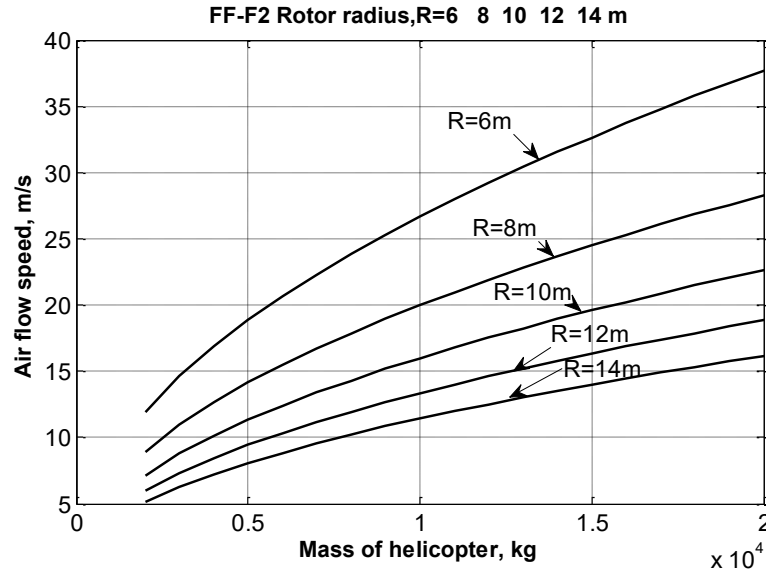
A typical fire speed is conventionally 0.5 – 5 km/hour (0.1 – 1.5 m/s) but fire can escalate as fast as 11 kilometers per hour (6.7 mph) in forests and 22 kilometers per hour (14 mph) in grasslands.

The air flow speed after leaving the helicopter rotor downwards can be computed by the equation:

$$P = mV, \quad m = \rho AV, \quad A = \pi R^2, \quad P = gM, \quad V = \frac{1}{R} \sqrt{\frac{gM}{\pi\rho}} \approx \frac{1.6\sqrt{M}}{R}, \quad (1)$$

where  $P$  is thrust, N;  $m$  is second mass of air flow, kg/m<sup>2</sup>;  $V$  is air flow speed, m/s;  $\rho = 1.225$  is air density, kg/m<sup>3</sup>;  $A$  is cross-section of air flow, m<sup>2</sup>;  $R$  is radius of helicopter rotor, m;  $g = 9.81$  is Earth's gravity, m/s<sup>2</sup>;  $M$  is helicopter mass, kg;  $\pi = 3.14$ .

Result of computations regarding the different helicopter masses and different radii of the helicopter rotor are presented in fig.8.



**Fig.8.** Air speed of wind generated under the helicopter rotor (propeller) vs. mass of helicopter and radius of the helicopter rotor.

If we use the notation  $q = V/A$  – specific load on the helicopter rotor,  $\text{kg}/\text{m}^2$ , we get from Eq.(1) the simpler equation

$$V = 2.83\sqrt{q}, \quad (2)$$

This equation may be more comfortable for purposes of comparison because the helicopter's  $q$  changes in a more narrow range than the helicopter mass or rotor radius of helicopter. The results of computation of equation (2) are presented in fig. 9.

#### Typical data of helicopters:

1) *Helicopter Bell 204B*. Commonly used for fire teams.

Radius of rotor  $R = 7.3$  m (24 ft).

Maximal mass  $M = 4310$  kg (9500 lb).

Power of engine 820 kW.

Capacity 1360 kg (3000 lb) or 8-9 passengers (fire team).

Cruise speed 205 km/h = 135 mph.

You can compute the air flow under this model's hovering rotor to be  $V = 14.3$  m/s = 51.7 km/h.

2) *Sikorsky S-76C++*.

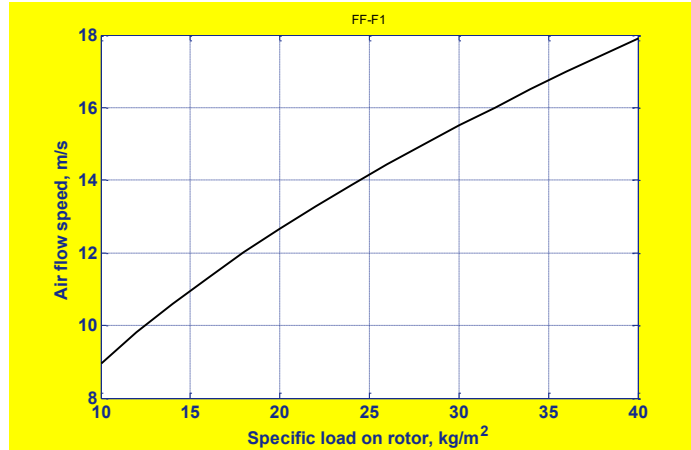
Radius of rotor  $R = 6.7$  m .

Maximal mass  $M = 5306$  kg.

Capacity 12 passengers.

Speed 287 km/h .





**Fig.9.** Air speed of a helicopter jet under the helicopter rotor (propeller) via specific load on helicopter rotor.

3) *CH-47 (military, two rotors).*

Radius of rotor  $R = 9.15$  m .

Maximal mass  $M = 12100$  kg.

Capacity 33-55 troops.

Engine power  $2 \times 2796$  kW .

If we use a conventional ventilator fan, the air flow speed after encountering the blade may be computed by equation (see Eqs. (1)):

$$\eta N = PV = \rho \pi R^2 V^3, \quad V = \sqrt[3]{\frac{\eta N}{\pi \rho R^2}}, \quad (3)$$

where  $N$  is engine power, W;  $\eta \approx 0.3 \div 0.7$  is the coefficient of fan (impeller, propeller) efficiency.

## Discussion

Mr. Melchor Duran has shown the efficiency of fire suppression by air jet in some experiments. For example, he set fire to a small benzene (gas) puddle and drove away the flames to extinction very efficiently with a conventional room fan. He also demonstrated the fan's capability to suppress a fire in other materials.

The testing of the offered method should be possible in the near term. Most forest fire teams in the USA have helicopters and cables. They can improvise a rig under supervision of an engineer, connect the helicopter by a hook to any strongly rooted tree trunk and drive away the fire by the helicopter air flow. For safety's sake in extreme crosswinds worsened by local topography, as Richard Cathcart has pointed out, the helicopter must have an emergency detach option effective within moments for rapid egress in case of a rapid and uncontrollable change in fire direction.

The helicopter produces a strong and swift air jet. The helicopter jet in most cases is stronger than most bursts of wind speed. That means we can drive away the flame into a place where no new fuel exists and thus extinguish the fire (Bolonkin 2008).

## Acknowledgement

The author wishes to acknowledge Joseph Friedlander (of Shave Shomron, Israel) for correcting the English and offering useful advice and suggestions.

## References:

1. Bolonkin A.A., (2009). The author's web page <http://Bolonkin.narod.ru/p65.htm> .
4. Bolonkin A.A., (2006), "Non-Rocket Space Launch and Flight", Elsevier, London, 488 pages.
5. Bolonkin A.A., (2008), "New Concepts, Ideas, Innovations in Aerospace, Technology and Human Science", NOVA, 502 pages.
6. Bolonkin A.A., Cathcart R.B., (2009), "Macro-Projects: Environment and Technology", NOVA , 536 pages.
7. *Wikipedia* (2009). Some background material in this article is gathered from Wikipedia under the Creative Commons license. . <http://wikipedia.org> , search "Forest Fire".



## Chapter 6B

# AB Wind Wall

### Abstract

Author suggests and researches a new revolutionary method for changing the climates of entire countries or portions thereof, obtaining huge amounts of cheap water and energy from the atmosphere. In this paper is presented the idea of a cheap artificial fabric wind wall, which may cardinaly change the climate of a large region or country. Additional benefits: The potential of tapping large amounts of fresh water and energy. The Walls has a parachute form and made from thin fabric (film) having heights of up to 3 - 5 km. They are located perpendicular to the main wind direction. Encountering these artificial walls, humid air (wind) rises to crest altitude, is cooled and produces rain (or rain clouds). Many natural mountains are sources of rivers, and other forms of water and power production - and artificial walls or mountains may provide these services for entire nations in the future. The wall is supported at altitude by wind, and is connected to the ground by thin cables. The author has shown (in previous works about the AB-Mountains and given articles) that this artificial wind wall allows control of the weather (rain, wind) and influences climate in a given region. This is a realistic and cheaper method of economical irrigation, getting energy and virtual weather control on Earth at the current time.

**Key words:** Local weather control, gigantic film AB-Dome, converting a dry region to subtropics, converting desolate wilderness to a prosperous region, macroprojects, induced rainfall, rainmaking, green power.

### Introduction

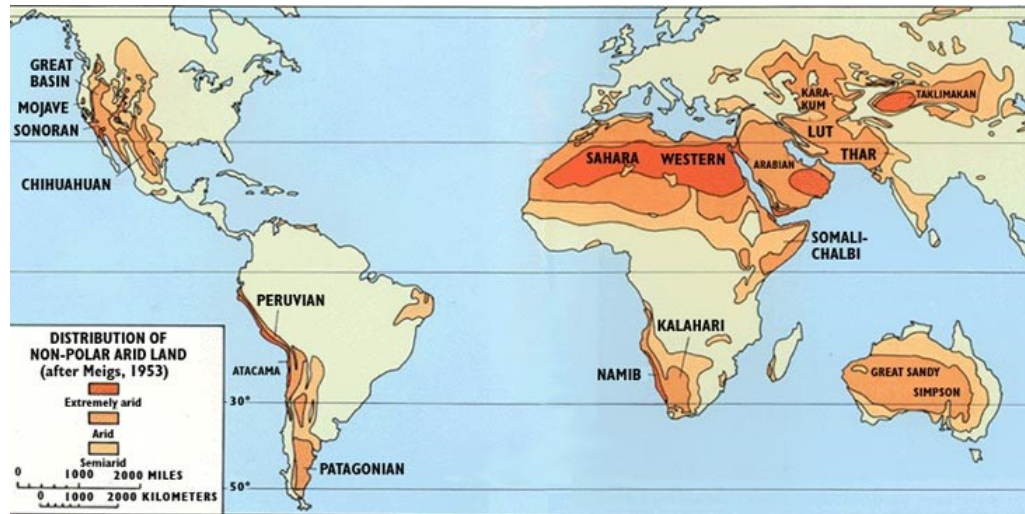
**1. Short History.** A particularly ambitious proposal evaluated in the Farmhand *Fencepost (Australia)* was to build a new mountain range (from soil and stone!) in the West of Australia, so as to create rain in the dry interior of Australia (Engineering the Weather, Part 10, p.115). The idea, first suggested by L.H Hogan in his book *Man Made Mountain*, is to build a very large mountain range 4 km tall, 10 km wide at the base, with a 2 km plateau at the top and covering a distance of 2,000 km. Purpose is to change the dry climate in the West of Australia. A trench approximately 100 meters deep, 200 km wide and 2,000 km long would be necessary to provide the amount of material to build the mountain range (400,000km<sup>3</sup>). It has been estimated that the construction of such a mountain would be more than \$100,000 billion (HWA, 2003). Given Australia national budget is \$178 billion, the price tag would be 500 times the national budget. If the new mountain (wind wall) were to create an extra 50 million ML of runoff each year, then the cost of the water would be more than \$100,000 per ML (\$100/kL) (HWA,2003). That was a visionary but impractical project proposal.

#### **Common information.**

**2. Climate.** Climate is the average and variations of weather in a region over long periods of time. Climate zones can be defined using parameters such as temperature and rainfall.

**3. Precipitation. General information about precipitation.** The extant amount of water in Earth's hydrosphere in the current era is constant. The average annual layer of Earth's precipitation is about 1000 mm or 511,000 km<sup>3</sup>. 21% of this (108,000 km<sup>3</sup>) falls on land and 79% (403,000 km<sup>3</sup>) on oceans. Most of it falls between latitudes 20° North and 20° South. Both polar zones collect only 4% of Earth's precipitation. The evaporation from the World-Ocean equals 1250 mm (450,000 km<sup>3</sup>). 1120 mm returns back as precipitation and 130 mm by river inflow. The evaporation from land equals 410 mm (61,000 km<sup>3</sup>), the precipitation is 720 mm. The land loses 310 mm as river flow to the oceans (47,000 km<sup>3</sup>). These are average data. In some regions the precipitation is very different (fig.1).

In meteorology, precipitation (also known as one class of hydrometeors, which are atmospheric water phenomena) is any product of the condensation of atmospheric water vapor that is deposited on the earth's surface. It occurs when the atmosphere (being a large gaseous solution) becomes saturated with water vapour and the water condenses and falls out of solution (i.e., precipitates). Air becomes saturated via two processes, cooling and adding moisture.



**Fig. 1.** Distribution non-polar arid land. 78 kb

Precipitation that reaches the surface of the earth can occur in many different forms, including rain, freezing rain, drizzle, snow, sleet, and hail. Virga is precipitation that begins falling to the earth but evaporates before reaching the surface. Precipitation is a major component of the hydrologic cycle, and is responsible for depositing most of the fresh water on the planet. Given the Earth's surface area, that means the globally-averaged annual precipitation is about 1 m, and the average annual precipitation over oceans is about 1.1 m.

Air contains moisture, measured in grams of water per kilogram (or  $\text{m}^3$ ) of dry air ( $\text{g}/\text{kg}$ ) or  $\text{g}/\text{m}^3$ , but most commonly reported as a relative humidity percentage. How much moisture a parcel of air can hold before it becomes saturated (100% relative humidity) depends on its temperature. Warmer air has a higher capacity for holding moisture than cooler air. Because of this property of the air, one way to saturate a parcel of air is to cool it. The dew point is the temperature that a parcel needs to be cooled to for saturation to occur.

Some cooling mechanisms include:

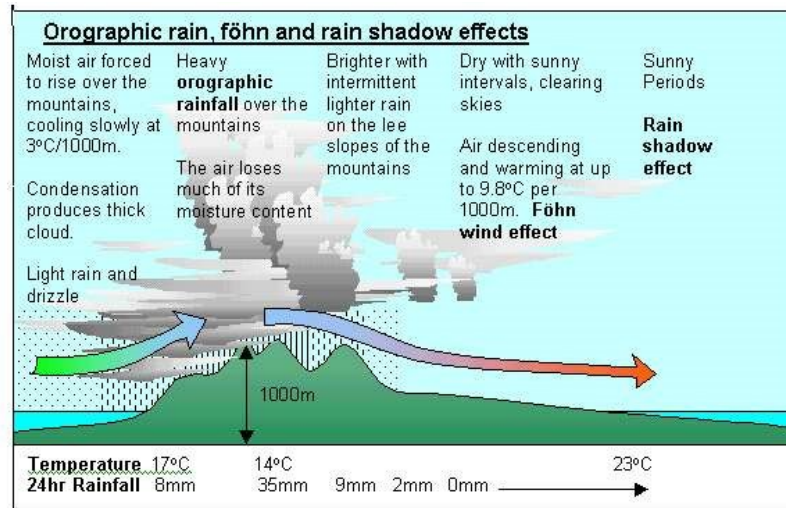
- Lift (convective, mechanical, positive vorticity advection)
  - Conductive cooling (warm air moves over a cool surface)
  - Radiational cooling (heat radiates off into space at night)
  - Evaporative cooling (air temperature falls as liquid water uses the energy to change phase to vapour).

The other way to saturate an air parcel is to add moisture to it, by:

- Precipitation falling from above (stratus forming in the rain under a higher cloud)
- Daytime heating evaporating water from the surface of oceans/lakes
- Drier air moving over open water (snow streamers off the Great Lakes in winter)



**4. Orographic effects.** *Orographic precipitation* occurs on the windward side of mountains and is caused by the rising air motion of a large-scale flow of moist air across the mountain ridge, resulting in adiabatic cooling and condensation.



**Fig.2.** Orographic precipitation. After encounter with mountain the atmospheric temperature is 5 – 7 C more than the air temperature before encounter because the air temperature increases (when air pressure increases) at low altitude and vapor condenses at high altitude. That air warming is an important benefit for countries which use the artificial mountains for protection from cold polar winds. 64 kb.

In mountainous parts of the world subjected to relatively consistent winds (for example, the trade winds), a more moist climate usually prevails on the windward side of a mountain than on the leeward (downwind) side. Moisture is removed by orographic lift, leaving drier air (see katabatic wind) on the descending (generally warming), leeward side where a rain shadow is observed.

Orographic precipitation is well known on oceanic islands, such as the Hawaiian Islands, where much of the rainfall received on an island is on the windward side, and the leeward side tends to be quite dry, almost desert-like, by comparison. This phenomenon results in substantial local gradients of average rainfall, with coastal areas receiving on the order of 500 to 750 mm per year (20 to 30 inches), and interior uplands receiving over 2.5 m per year (100 inches). Leeward coastal areas are especially dry 500 mm per year (20 inches) at Waikiki, and the tops of moderately high uplands are especially wet – ~12 m per year (~475 inches) at Wai'ale'ale on Kaua'i.

In South America, the Andes mountain range blocks most of the Atlantic moisture that arrives in that continent, resulting in a desert-like climate on the Pacific coast of Peru and northern Chile, since the cold Humboldt Current ensures that the air off the Pacific is dry as well. On the leeward side of the Andes is the Atacama Desert of Chile. It is also blocked from moisture by mountains to its west as well. Not coincidentally, it is the driest place on earth. The Sierra Nevada range creates the same effect in North America forming the Great Basin desert, Mojave Desert and Sonoran Desert.

**5. Wind.** Wind is the flow of air. More generally, it is the flow of the gases which compose an atmosphere; since wind is not unique to Earth. Simply it occurs as air is heated by the sun and thus rises. Cool air then rushes in to occupy the area the now hot air has moved from. It could be loosely classed as a convection current. Winds are commonly classified by their spatial scale, their speed, the types of forces that cause them, the geographic regions in which they occur, or their effect.

There are global winds, such as the wind belts which exist between the atmospheric circulation cells. There are upper-level winds which typically include narrow belts of concentrated flow called jet

streams. There are synoptic-scale winds that result from pressure differences in surface air masses in the middle latitudes, and there are winds that come about as a consequence of geographic features, such as the sea breezes on coastlines or canyon breezes near mountains. Mesoscale winds are those which act on a local scale, such as gust fronts. At the smallest scale are the microscale winds, which blow on a scale of only tens to hundreds of meters and are essentially unpredictable, such as dust devils and microbursts.

Forces which drive wind or affect it are the pressure gradient force, the Coriolis force, buoyancy forces, and friction forces. When a difference in pressure exists between two adjacent air masses, the air tends to flow from the region of high pressure to the region of low pressure. On a rotating planet, flows will be acted upon by the Coriolis force, in regions sufficiently far from the equator and sufficiently high above the surface.

The three major driving factors of large scale global winds are the differential heating between the equator and the poles (difference in absorption of solar energy between these climate zones), and the rotation of the planet. Winds can shape landforms, via a variety of aeolian processes.

Some local winds blow only under certain circumstances, i.e. they require a certain temperature distribution. Differential heating is the motive force behind land breezes and sea breezes (or, in the case of larger lakes, lake breezes), also known as on- or off-shore winds. Land absorbs and radiates heat faster than water, but water releases heat over a longer period of time. The result is that, in locations where sea and land meet, heat absorbed over the day will be radiated more quickly by the land at night, cooling the air. Over the sea, heat is still being released into the air at night, which rises. This convective motion draws the cool land air in to replace the rising air, resulting in a land breeze in the late night and early morning. During the day, the roles are reversed. Warm air over the land rises, pulling cool air in from the sea to replace it, giving a sea breeze during the afternoon and evening.

**Some Information about Wind Energy at altitude.** The power of a wind engine strongly depends on the wind speed (to the third power). Low altitude wind ( $H = 10$  m) has the standard average speed  $V = 6$  m/s. High altitude wind is powerful and that has another important advantage, it is stable and constant. This is true practically everywhere.

Wind in the troposphere and stratosphere are powerful and permanent. For example, at an altitude of 5 km, the average wind speed is about 20 M/s, at an altitude 10-12 km the wind may reach 40 m/s (at latitude of about 20-35°N).

There are permanent jet streams at high altitude. For example, at  $H = 12-13$  km and about 25°N latitude. The average wind speed at its core is about 148 km/h (41 m/s). The most intensive portion, with a maximum speed 185 km/h (51 m/s) latitude 22°, and 151 km/h (42 m/s) at latitude 35° in North America. On a given winter day, speeds in the jet core may exceed 370 km/h (103 m/s) for a distance of several hundred miles along the direction of the wind. Lateral wind shears in the direction normal to the jet stream may be 185 km/h per 556 km to right and 185 km/h per 185 km to the left.

The wind speed of  $V = 40$  m/s at an altitude  $H = 13$  km provides 64 times more energy than surface wind speeds of 6 m/s at an altitude of 10 m.

This is a gigantic renewable and free energy source. (See reference: Science and Technology, v.2, p.265).

**Mountain breezes and valley breezes** are due to a combination of differential heating and geometry. When the sun rises, it is the tops of the mountain peaks which receive first light, and as the day progresses, the mountain slopes take on a greater heat load than the valleys. This results in a temperature inequity between the two, and as warm air rises off the slopes, cool air moves up out of the valleys to replace it. This upslope wind is called a *valley breeze*. The opposite effect takes place in the afternoon, as the valley radiates heat. The peaks, long since cooled, transport air into the valley in a process that is partly gravitational and partly convective and is called a *mountain breeze*.

Mountain breezes are one example of what is known more generally as a katabatic wind. These are winds driven by cold air flowing down a slope, and occur on the largest scale in Greenland and Antarctica...Most often, this term refers to winds which form when air which has cooled over a high, cold plateau is set in motion and descends under the influence of gravity. Winds of this type are common in regions of Mongolia and in glaciated locations.

Because *katabatic* refers specifically to the vertical motion of the wind, this group also includes winds which form on the lee side of mountains, and heat as a consequence of compression. Such winds may undergo a temperature increase of 20 °C (36 °F) or more, and many of the world's "named" winds (see list below) belong to this group. Among the most well-known of these winds are the chinook of Western Canada and the American Northwest, the Swiss föhn, California's infamous Santa Ana wind, and the French Mistral. The opposite of a katabatic wind is an anabatic wind, or an upward-moving wind. The above-described *valley breeze* is an anabatic wind. A widely-used term, though one not formally recognised by meteorologists, is *orographic wind*. This refers to air which undergoes orographic lifting. Most often, this is in the context of winds such as the chinook or the föhn, which undergo lifting by mountain ranges before descending and warming on the lee side.

A **sea-breeze** (or **onshore breeze**) is a wind from the sea that develops over land near coasts. It is formed by increasing temperature differences between the land and water which create a pressure minimum over the land due to its relative warmth and forces higher pressure, cooler air from the sea to move inland.

**Land breezes.** At night, the land cools off quicker than the ocean due to differences in their specific heat values, which forces the dying of the daytime sea breeze. If the land cools below that of the adjacent sea surface temperature, the pressure over the water will be lower than that of the land, setting up a land breeze as long as the environmental surface wind pattern is not strong enough to oppose it. If there is sufficient moisture and instability available, the land breeze can cause showers or even thunderstorms, over the water. Overnight thunderstorm development offshore can be a good predictor for the activity on land the following day, as long as there are no expected changes to the weather pattern over the following 12-24 hours. The land breeze will die once the land warms up again the next morning.

**6. Mountains.** A mountain is a landform that extends above the surrounding terrain in a limited area. A mountain is generally steeper than a **hill**, but there is no universally accepted standard definition for the height of a mountain or a hill although a mountain usually has an identifiable summit. Mountains cover 54% of Asia, 36% of North America, 25% of Europe, 22% of South America, 17% of Australia, and 3% of Africa. As a whole, 24% of the Earth's land mass is mountainous. 10% of people live in mountainous regions. Most of the world's rivers are fed from mountain sources, and more than half of humanity depends on mountains for water.

Sufficiently tall mountains have very different climatic conditions at the top than at the base, and will thus have different life zones at different altitudes. The flora and fauna found in these zones tend to become isolated since the conditions above and below a particular zone will be inhospitable to those organisms. These isolated ecological systems are known as sky islands and/or microclimates. Tree forests are forests on mountain sides which attract moisture from the trees, creating a unique ecosystem. Very tall mountains may be covered in ice or snow.



Air as high as a mountain is poorly warmed and, therefore, cold. Air temperature normally drops 1 to 2 degrees Celsius (1.8 to 3.6 degrees Fahrenheit) for each 300 meters (1000 feet) of altitude.

**7. Humidity.** The term humidity is usually taken in daily language to refer to relative humidity. Relative humidity is defined as the amount of water vapor in a sample of air compared to the maximum amount of water vapor the air can hold at any specific temperature. Humidity may also be expressed as Absolute humidity and specific humidity. Relative humidity is an important metric used in forecasting weather. Humidity indicates the likelihood of precipitation, dew, or fog. High humidity makes people feel hotter outside in the summer because it reduces the effectiveness of sweating to cool the body by preventing the evaporation of perspiration from the skin. This effect is calculated in a heat index table. Warm water vapor has more thermal energy than cool water vapor and therefore more of it evaporates into warm air than into cold air.

**8. A desert** is a landscape form or region that receives very little precipitation. Deserts are defined as areas that receive an average annual precipitation of less than 250 mm (10 in). In the Köppen climate classification system, deserts are classed as (BW).

Deserts take up one-third of the Earth's land surface. They usually have a large diurnal and seasonal temperature range, with high daytime temperatures (in summer up to 45 °C or 113 °F), and low nighttime temperatures (in winter down to 0 °C; 32 °F) due to extremely low humidity. Water acts to trap infrared radiation from both the sun and the ground, and dry desert air is incapable of blocking sunlight during the day or trapping heat during the night. Thus during daylight all of the sun's heat reaches the ground. As soon as the sun sets the desert cools quickly by radiating its heat into space. Urban areas in deserts lack large (more than 25 °F/14 °C) daily temperature ranges, partially due to the urban heat island effect.

Many deserts are shielded in rain by rain shadows, mountains blocking the path of precipitation to the desert. Deserts are often composed of sand and rocky surfaces. Sand dunes called ergs and stony surfaces called hamada surfaces compose a minority of desert surfaces. Exposures of rocky terrain are typical, and reflect minimal soil development and sparseness of vegetation.

Bottomlands may be salt-covered flats. Eolian processes are major factors in shaping desert landscapes. Cold deserts (also known as polar deserts) have similar features but the main form of precipitation is snow rather than rain. Antarctica is the world's largest cold desert (composed of about 98 percent thick continental ice sheet and 2 percent barren rock). The largest hot desert is the Sahara. Deserts sometimes contain valuable mineral deposits that were formed in the arid environment or that were exposed by erosion.

Rain does fall occasionally in deserts, and desert storms are often violent. A record 44 millimeters (1.7 in) of rain once fell within 3 hours in the Sahara. Large Saharan storms may deliver up to 1 millimeter per minute. Normally dry stream channels, called arroyos or wadis, can quickly fill after heavy rains, and flash floods make these channels dangerous.

Though little rain falls in deserts, deserts receive runoff from ephemeral, or short-lived, streams fed considerable quantities of sediment for a day or two. Although most deserts are in basins with closed or interior drainage, a few deserts are crossed by 'exotic' rivers that derive their water from outside the desert. Such rivers infiltrate soils and evaporate large amounts of water on their journeys through the deserts, but their volumes are such that they maintain their continuity. The Nile River, the Colorado

River, and the Yellow River are exotic rivers that flow through deserts to deliver their sediments to the sea. Deserts may also have underground springs, rivers, or reservoirs that lay close to the surface, or deep underground. Plants that have not completely adapted to sporadic rainfalls in a desert environment may tap into underground water sources that do not exceed the reach of their root systems.

Lakes form where rainfall or meltwater in interior drainage basins is sufficient. Desert lakes are generally shallow, temporary, and salty. Because these lakes are shallow and have a low bottom gradient, wind stress may cause the lake waters to move over many square kilometers. When small lakes dry up, they leave a salt crust or hardpan. The flat area of clay, silt, or sand encrusted with salt that forms is known as a playa. There are more than a hundred playas in North American deserts. Most are relics of large lakes that existed during the last ice age about 12,000 years ago. Lake Bonneville was a 52,000 kilometers<sup>2</sup> (20,000 mi<sup>2</sup>) lake almost 300 meters (1000 ft) deep in Utah, Nevada, and Idaho during the Ice Age. Today the remnants of Lake Bonneville include Utah's Great Salt Lake, Utah Lake, and Sevier Lake. Because playas are arid landforms from a wetter past, they contain useful clues to climatic change.

When the occasional precipitation does occur, it erodes the desert rocks quickly and powerfully. Winds are the other factor that erodes deserts—they are slow yet constant.

A desert is a hostile, potentially deadly environment for unprepared humans. The high heat causes rapid loss of water due to sweating, which can result in dehydration and death within days. In addition, unprotected humans are also at risk from heatstroke and venomous animals. Despite this, some cultures have made deserts their home for thousands of years, including the Bedouin, Touareg and Puebloan people. Modern technology, including advanced irrigation systems, desalinization and air conditioning have made deserts much more hospitable. In the United States and Israel, desert farming has found extensive use.

The Great Sandy Desert has nearly all its rain during from monsoonal thunderstorms or the occasional tropical cyclone rain depression. Thunderstorm days average 20-30 annually through most of the area (Burbidge 1983) although the desert has fairly high precipitation rates due to the high rates of evaporation this area remains an arid environment with vast areas of sands.

Other areas of the world, which see these rare precipitation events in drylands, are Northwest Mexico, South West America, and South West Asia. In North America in the Sonoran and Chihuahuan desert have received some tropical rainfall in the last 10 years. Tropical activity is rare in all deserts but what rain does arrive here is important to the delicate ecosystem existing.

**9. Aridity.** In general terms, the climate of a locale or region is said to be **arid** when it is characterized by a severe lack of available water, to the extent of hindering or even preventing the growth and development of plant and animal life. As a result, environments subject to arid climates tend to lack vegetation and are called xeric or desertic.

The expression 'available water' refers to water in the soil in excess to the wilting point. The air over a hot desert may actually contain substantial amounts of water vapor but that water may not be generally accessible to plants, except for very specialized organisms (such as some species of lichen). 'Lack of water' refers to use by plants. The water that is actually present in the environment may be sufficient for some species or usages (such as climax vegetation), and grossly insufficient for others. **Aridity**, the characteristic nature of arid climates, may thus depend on the use of the land. Regards to the presence

of life, what is more important than the degree of rainfall is the fraction of precipitation that is not quickly lost through evaporation or runoff. Attempts to quantitatively describe the degree of aridity of a place has often led to the development of aridity indexes. There is no universal agreement on the precise boundaries between classes such as 'hyper-arid', 'arid', 'semi-arid', etc.



**Fig. 3.** Sahara desert. 98 kb.

If different classification schemes and maps differ in their details, there is a general agreement about the fact that large areas of the Earth are considered arid. These include the hot deserts located broadly in sub-tropical regions, where the accumulation of water is largely prevented by either low precipitations, or high evaporation, or both, as well as cold deserts near the poles, where water may be permanently locked in solid forms (snow and ice). Other arid regions include areas located in the rain shadows of major mountain ranges or along coastal regions affected by significant upwelling (such as the Atacama Desert).

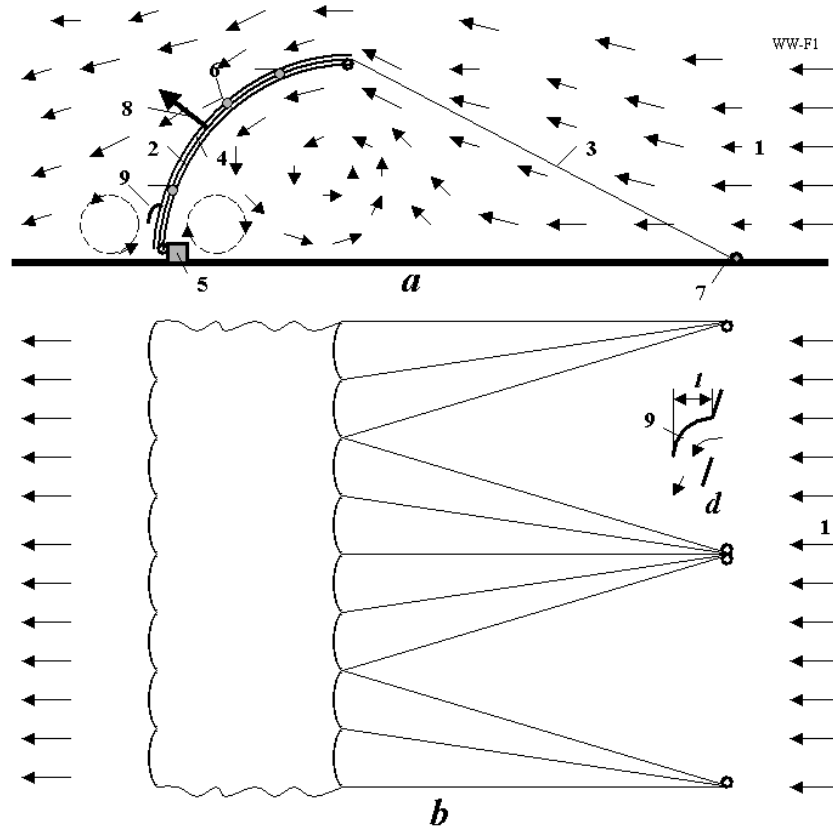
The distribution of aridity observed at any one point in time is largely the result of the general circulation of the atmosphere. The latter does change significantly over time through climate change. In addition, changes in land use can result in greater demands on soil water and induce a higher degree of aridity.

**10. Control of local weather.** Governments spend billions of dollars merely studying the weather. The many big government research scientific organizations and perhaps a hundred thousand of scientists have been studying Earth's weather for more than a hundred years. There are gigantic numbers of scientific works about weather control. Most of them are impractical. We cannot exactly predict weather at long period, to avert a rain, strong wind, storm, tornado, or hurricane. We cannot control the clouds, temperature and humidity of the atmosphere, nor the power of rain. We cannot make more tolerable a winter or summer. We cannot convert a cold region to subtropics, a desolate wilderness to a prosperous region. We can only observe the storms and hurricanes and approximately predict their direction of movement. It is as if all the police department did was announce which neighborhoods were infested with killers and best avoided! Every year terrible storms, hurricanes, strong winds and rains and inundations destroy thousands of houses, kill thousands of men.

## DESCRIPTION AND INNOVATIONS

**Idea and Innovations.** The idea here is creating a cheap Wind Wall (WW)(Figs. 3, 6) from a thin fabric (film) whose presence forces humid air (a wet wind) to rise to high altitude. It is well known that air expands and cools at altitude. The air humidity decreases, exceeds the maximal saturation level and superfluous water vapor condenses in various forms, including rain or rain clouds. Early author offered the inflatable Mountains and Dome from transparency thin film [1]- [17].

The wind wall has (fig.4) light fabric (or film) 2, support cable 3, water-electric station 5 and control 7. The fabric has tubes 4 and safety valves 6. The installation works the following way: The wind blows, fills and tensions the fiber, creates drag-lift force 8 and supports the wall at high altitude in open form as in a conventional parachute. In a storm the fabric can lay down by control 7. If the wind is very strong, the safety valves 6 automatically open and decrease the wall stress. The wall has special lift holes 9 which direct part of the air downward and produce additional lift force which helps to keep the wall at altitude.

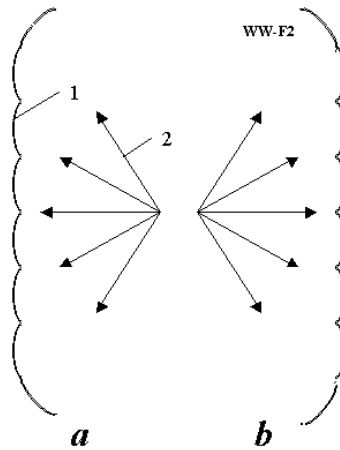


**Fig. 4.** Fabric AB-Wind Wall of a semi-parachute form. *a)* Side view, *b)* Top view, *d)* Lift hole. *Notation:* 1 – wind; 2 – fabric wall, 3 – support cable (it may has support wing); 4 – water tube for rain; 5 – water electric station; 7 – control of wall height, 8 - summary drag-lift force of wall; 9 – lift hole. Wall height is about 3 – 5 km.

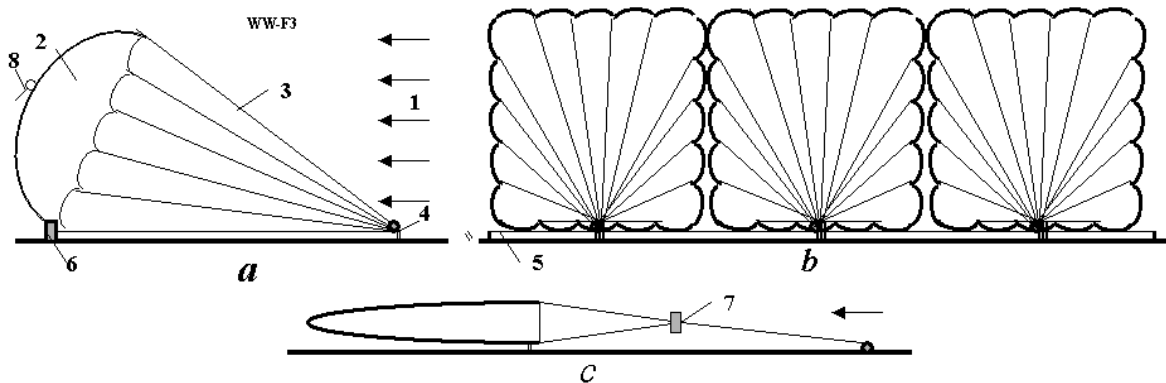
The offered wind wall can work in a wide range of wind directions (fig.5)(300 from 360 degrees). A bent wall edge 3 (fig. 5) decrease the wall efficiency. If wind will flow from opposite (left) side, the support cable 3 and control devices 7 may be located on the other side. (for reversibility)

The wind wall can have the form of a full square parachute (fig. 6). This installation may be from separated blocks, cheaper and easier for building than the version of fig. 4. Version 2 may have the

safety cable 5 (fig. 6), which saves the parachute from Earth's friction. Version 2 may be mobile. Both versions can have the control 7 (fig. 6). That allows changing the active area and height of the wind wall.



**Fig. 5.** The fabric wall is worked in widely diapason of wind direction. *a)* Wind is from right side; *b)* Wind is from left side. *Notation:* 1 – fabric wall; 2 – direction of wind, 3 – bend edge.



**Fig. 6.** Full (quadratic) parachute form of mobile AB Wind Wall. *a)* Side view, *b)* Front view, *c)* Wall with decreased height. *Notations:* 1 – wind; 2 – wall of parachute form; 3 – cords; 4 – control; 5 – safety cable; 6 – water-electric station; 7 – control of parachute height; 8 – safety valve and lift hole.

The wind may be absent on Earth's surface, but one are the most days in year at high altitude. The wind wall is useful only in wind weather. If we have enough (surplus) a water and energy, we can temporary not use the wind wall.

Fig. 7 illustrates the control wall we envision. The inflated textile shell—technical “textiles” can be woven or non-woven (films)—embodies the innovations listed: (1) the film (fabric) is very thin, approximately 0.1 to 5 mm. A film this thin has never before been used in a major building; (2) the film (fabric) has two strong nets, with a mesh of about  $0.1 \times 0.1$  m and  $a = 1 \times 1$  m, the threads are about additional 0.5 mm for a small mesh and about 1 mm for a big mesh. The net prevents the watertight and airtight film covering from being damaged by vibration; (3) the film incorporates (optional) a tiny electrically conductive wire net with a mesh about  $0.1 \times 0.1$  m and a line width of about  $100 \mu$  (microns) and a thickness near  $10 \mu$ . The wire net is electric (voltage) control conductor. It can inform the wall maintenance engineers concerning the place and size of film damage (tears, rips, etc.).

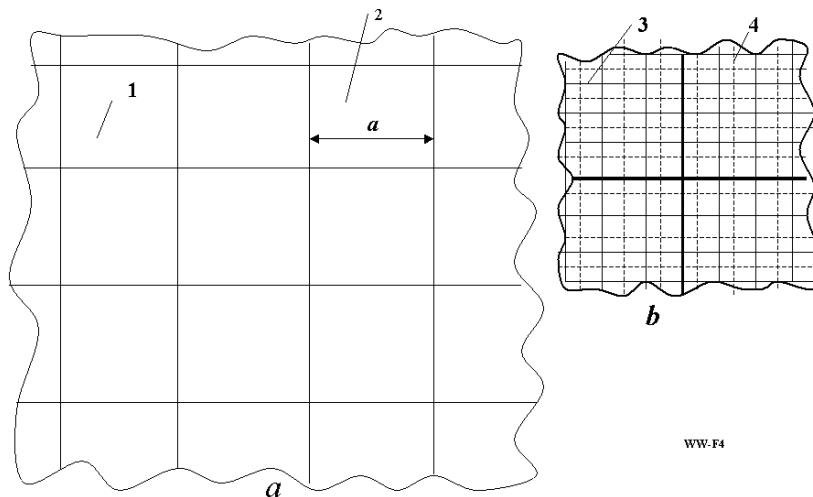
In cold regions the film may be covered by thin aluminum layers and concentrate the Sun light (heat) near the wall by reflection.

Special film may be used in a more complex wall design if the Sun is located to windward and we want to have finely control conditions in area after wall [1]. Envisioned is a cheap film having liquid crystal and conducting layers. The clarity is controlled by electric voltage. These layers, by selective control, can pass or blockade the solar light (or parts of solar spectrum) and pass or blockade the Earth's radiation.

The incoming and outgoing radiations have different wavelengths. That makes control of them separately feasible and therefore possible to manage the heating or cooling of the Earth's surface under this film. In conventional conditions about 50% of the solar energy reaches the Earth surface. Much is reflected back to outer space by the white clouds. In open atmosphere, the Sun heats the ground; the ground must heat the whole troposphere (6 – 10 km) before stable temperature rises are achieved. In our case the ground heats ONLY the air under wall (as in a hotbed). We have a literal greenhouse effect, for the 'overroof' prevents the hot air escaping. The temperature of air after wall decreases in 3 – 5 C. That means that many cold regions (Alaska, Siberia, North Canada) may absorb more solar energy and become a more warm temperate local climate. That also means, by increasing the albedo of the wall, that the Sahara and other deserts can be a prosperous local area with a fine growing and living climate.

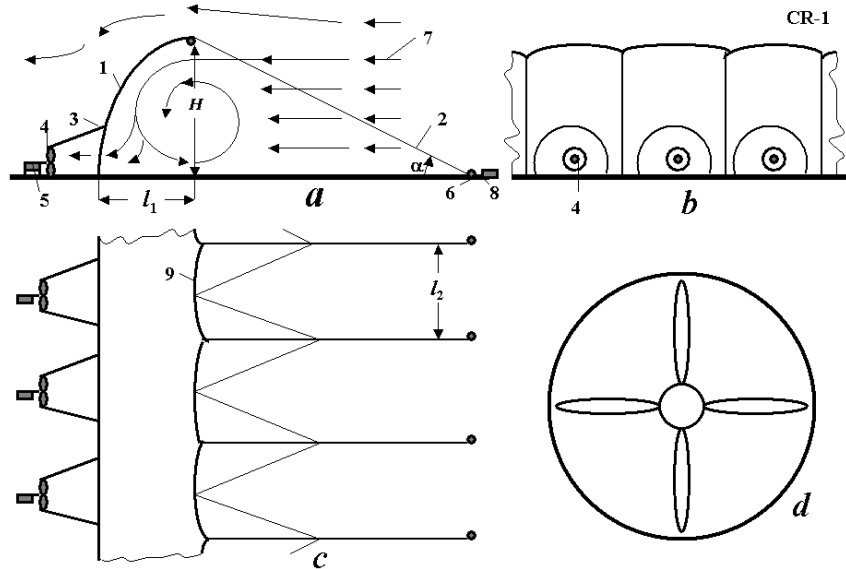
The building of a wind wall is very easy. We spread out the collapsed fabric (film) over Earth's surface. When wind blows the film is raised by wind air overpressure to the needed altitude limited by fabric area and the support cables. Damage to the film is not a major trouble because and at worst we lose some wind pressure and water vapor.

The offered Wind Wall is very suitable for ground windmills (fig. 8). The air to windward produces the high air pressure which is more than ground wind pressure (the wind speed is greater, and contained energy vastly greater, at high altitude). For the same reason the air pressure downwind of the wall is less than upwind. The conic entry to the turbine increases the wind speed and air turbine can produce a high energy yield.



**Fig. 7.** Design of covering fabric (film). *Notations:* (a) Big fragment of cover, (b) Small fragment of cover. *Notations:* 1 - cover; 2 - mesh; 3 - small mesh; 4 - thin electric net.

The Fabric Aerial Wall (FAW) is diagramed in Fig. 8.



**Fig. 8.** Fabric Aerial Wall and Wind Turbine Station. (a) side-view, (b) front-view, (c) top view, (d) wind engine. *Notation:* 1-flexible fabric aerial wall, 2-tethering cables, 3-air channel, 4-air turbine (propeller), 5-electricity generator, 6-support cable spool, 7-wind, 8-spool motor, 9-film (fabric) cable.  $H$  - deployed elevation of FAW.

**The first main innovation** of the offered AB-Wind Wall is the inflatable HIGH span of the enclosed covering (up to 3 – 5 km). The great vertical scale height of the enclosed volume aids organizing the rise of humid air at high altitude. The air is cooling and in that process, producing a lot of water which may be collected by rain channels on the AB-Wall at high altitude and make much energy in hydroelectric turbines located on Earth's surface as the waters descend. This freshwater may be used for irrigation or sale [1, 17]. The rest of the water will be precipitating as rain in near regions and can change a dry environment for a given region to a subtropical climate (the size of the region depends upon the size of the offered artificial mountain range).

We can convert the desert and desolate wildernesses into gardens. Good soil is not a necessity--hydroponics allows us to achieve record harvests on any soil.

**The second important innovation** is control of wind wall height. That allows reaching a maximum efficiency of water extraction and effective 'control' of regional weather.

**The third innovation** is using the high altitude of collected water for production of hydroelectric energy.

**The fourth important innovation** is the use of cheap thin film (fabric) for building of AB-Wall. This innovation decreases the construction cost by many millions of times in comparison to make the artificial 3 – km Wall from soil and stones! Also, in case of improved climate modeling, when we find that moving the 'mountain range' just a little bit over would be a vast improvement—the very subject is not impossible even to consider.

**The fifth innovation** is using cheap controlled heat conductivity, (controlled clarity is optionally needed for some regions). This innovation allows conserving solar heat (in cold regions), to control the temperature in the local region (in hot climates). That allows the user to get two to three rich crops annually in middle latitudes and to convert the cold zones (Siberia, North Canada, Alaska, etc.) to good single-crop regions.

**The sixth innovation** is using the cool water from the artificial Wall for cooling of buildings, crops, condensers, etc.

**The seventh innovation** is using the artificial Wall for windmills having high power (tens kW/m).



**The eighth innovation** is using the high water pressure (up 300 - 500 atm) for delivery of freshwater over long distances by tubes without pump stations.

**The ninth innovation** is control of cover reflectivity which allows to influence climate of outer regions in some circumstances.

**The tenth innovation** is noted above lift hole. They direct the part of air to down and create the additional lift force. That lift force helps to keep the lower part of wall at altitude.

**Advantages and disadvantages** offered Wind Wall with comparison the Artificial Inflatable Mountains offered in [1]:

*Advantages:*

1. The wind wall is cheaper by 2 - 3 times because it requests less film (fabric) by two times, the film is simpler, building is easier.
2. The wind wall is easy to relocate to another place (mobility).

*Disadvantages:*

1. The wind wall is dependent on wind. If wind is weak, the wall drifts down to ground. That may happen some times in the year. If wind increases, the wall automatically rises to altitude. The control mechanisms are more complex and the Wind Wall requires more service personnel per unit of generated water and power. On the other hand, in many locations, effective rainfall of an AB-Mountain might be largely seasonal; the decision must be made site by site.
2. No additional effect from closed-loop cycle 'within' the Wall.

The Wind Wall may be used for simple protection from small rockets (for example, Kassam) and low altitude missiles because that wall may brake, put down by impact or cause a pre-aimed rocket to lose its way. Such a Protection Wall can have a lee side 'shielding effect' and be arranged for optimum interception height.

Lest it be objected that such Wall would take impractical amounts of plastic, consider that the world's plastic production is today on the order of 100 million tons. If, with economic growth, this amount doubles over the next generation and the increase is used for doming over territory, at 300 - 500 tons a square kilometer 200,000 square kilometers could be roofed over annually. While small in comparison to the approximately 150 million square kilometers of land area, consider that 200,000 1 kilometer sites scattered over the face of the Earth newly made habitable could revitalize vast swaths of land surrounding them—one square kilometer could grow local vegetables for a city in the desert, one over there could grow biofuel, enabling a desolate South Atlantic island to become fuel independent; at first, easily a billion people a year could be taken out of sweltering heat, biting cold and slashing rains, saving the money buying and running heating and air conditioning equipment would require.

Part of the covering can have a very thin shiny aluminum coating that is about  $1\mu$  (micron) for reflection of unnecessary solar radiation in equatorial or retention of additional solar radiation in the polar regions [1-16].

The author offers a method for moving off the snow and ice from the film at high altitude or in polar regions. For example, if we decrease the altitude, the wall will be in more warm air and ice, snow will be deleted. The other method is pain the top part of wall in dark color. The Sun will heat this part and snow and ice melt and put down because the fabric (film) vibrate and fabric surface has slope.

The town cover may be used as a screen for projecting of pictures, films and advertising on the cover at night time.

## Theory, Estimations and Computations of AB-Wind Wall

As wind flows over and around a fully exposed, nearly completely sealed inflated wall, the weather affecting the external film (fabric) on the windward side must endure positive air pressures as the wind stagnates. Simultaneously, low air pressure eddies will be present on the leeward side of the wall. In other words, air pressure gradients caused by air density differences on different parts of the wall's envelope is characterized as the "buoyancy effect". The buoyancy effect will be greatest during the coldest weather when the Wall is heated and the temperature difference between its interior and exterior are greatest. In extremely cold climates such as the Arctic and Antarctic Regions the buoyancy effect tends to dominate wall pressurization.

A reader can derive the equations below from well-known physical laws [18]. Therefore, the author does not give detailed explanations of these.

2. **Amount of water in atmosphere.** Amount of water in atmosphere depends upon temperature and humidity. For relative humidity 100%, the maximum partial pressure of water vapor is shown in Table 1.

3.

**Table 1.** Maximum partial pressure of water vapor in atmosphere for given air temperature

$t, C$	-10	0	10	20	30	40	50	60	70	80	90	100
$p, kPa$	0.287	0.611	1.22	2.33	4.27	7.33	12.3	19.9	30.9	49.7	70.1	101

The amount of water in  $1 \text{ m}^3$  of air may be computed by equation

$$m_w = 0.00625[p(t_2)h - p(t_1)], \quad (1)$$

where  $m_w$  is mass of water, kg in  $1 \text{ m}^3$  of air;  $p(t)$  is vapor (steam) pressure from Table 1, kPa;  $h = 0 \div 1$  is relative humidity;  $t$  is temperature, C.

The computation of equation (1) is presented in fig.9. Typical relative humidity of atmosphere air is 0.5 - 1.

### 2. Air temperature, density, and pressure versus altitude in troposphere.

Standard atmosphere is in Table 2.

**Table 2.** Standard atmosphere.  $\rho_0 = 1.225 \text{ kg/m}^3$

$H, \text{ km}$	0	0.4	1	2	3	4	5	6
$t, \text{ }^\circ\text{K}$	288.2	285.6	281.9	275.1	268.6	262.1	265.6	247.8
$t, \text{ }^\circ\text{C}$	15	12.4	8.5	2	-4.5	-11	-17.5	-24
$\rho/\rho_0$	0	0.907	0.887	0.822	0.742	0.669	0.601	0.538

Temperature, relative air density and pressure of troposphere (up 10 km) versus the altitude computed by equations:

$$T = T_0 - 0.0065H, \quad \bar{\rho} = \frac{\rho}{\rho_0} = \left(1 - \frac{H}{44300}\right)^{4.265}, \quad \bar{p} = \frac{p}{p_0} = \left(1 - \frac{H}{44300}\right)^{5.265}, \quad (2)$$

where  $T_0 = 15 \text{ C}$ ,  $\rho_0 = 1.225 \text{ kg/m}^3$ ,  $p_0 = 10^5 \text{ N/m}^2$  are air temperature, density and pressure at sea level,  $H = 0$ ;  $H$  is altitude, m;  $T, \rho, p$  are air temperature, density and pressure at altitude  $H$ , m. The computation of temperature via altitude are presented in fig. 10, 11.

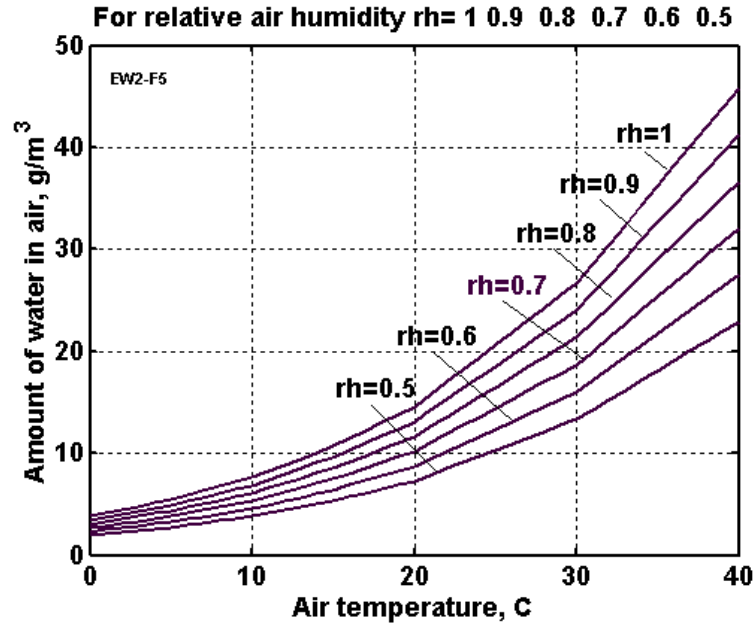


Fig. 9. Amount of water in 1 m<sup>3</sup> of air versus air temperature and relative humidity (rh).  $H = 0$  km,  $t_l = 0$  °C. 36 kb.

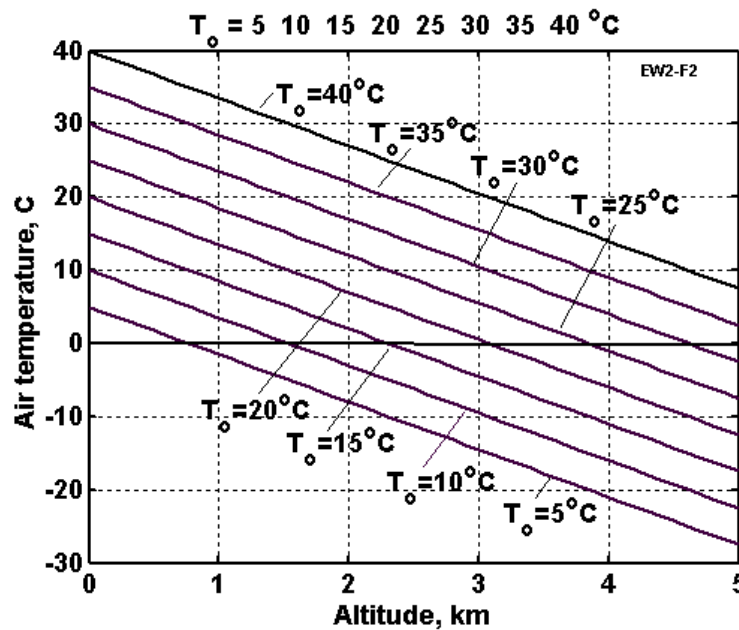


Fig.10. Air temperature versus the altitude for different temperatures.

After the encounter with the AB-Wall range the atmospheric temperature is 5 – 7 C higher, because the air temperature increases when air pressure increases at low altitude. The analogy is to an air compressor; denser fractions are usually hotter. The water vapor is condensed and gives up its' heat to air. That additional air warming is important for countries which use the artificial AB-Walls for protection from cold polar winds.

**3. Altitude and wind speed.** Wind speed,  $V$ , increases with altitude,  $H$ , as follows

$$\bar{V} = V/V_0 = (H/H_0)^\alpha, \quad (3)$$

where  $\alpha = 0.1 - 0.25$  exponent coefficient depending upon surface roughness. When the surface is water,  $\alpha = 0.1$ ; when surface is shrubs and woodlands  $\alpha = 0.25$ . The sub "0" means the data at Earth surface. The standard values for wind computation are  $V_o = 6$  m/s,  $H_o = 10$  m/s. The computation of this equation are presented in fig. 12. At high altitude the wind speed may be significantly more than equation (3) gives.

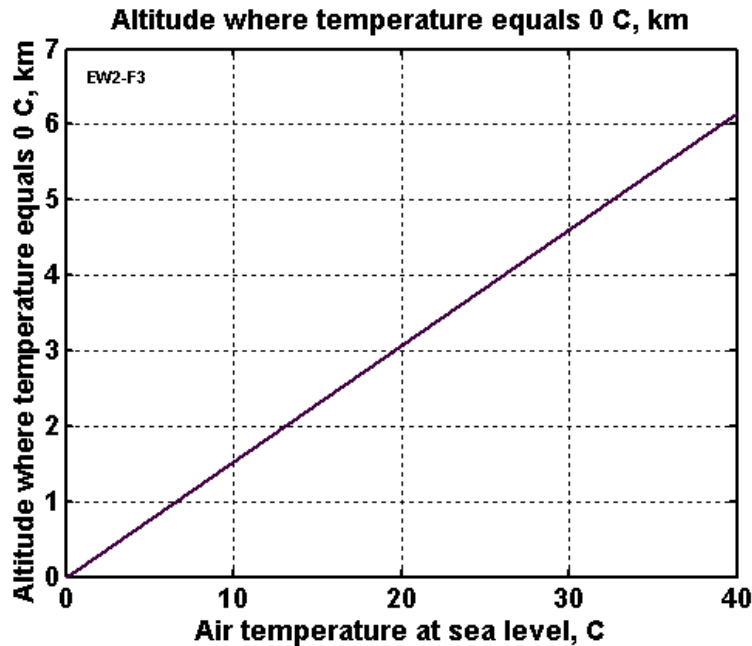


Fig.11. Altitude where temperature equals 0°C via air temperature at sea level.

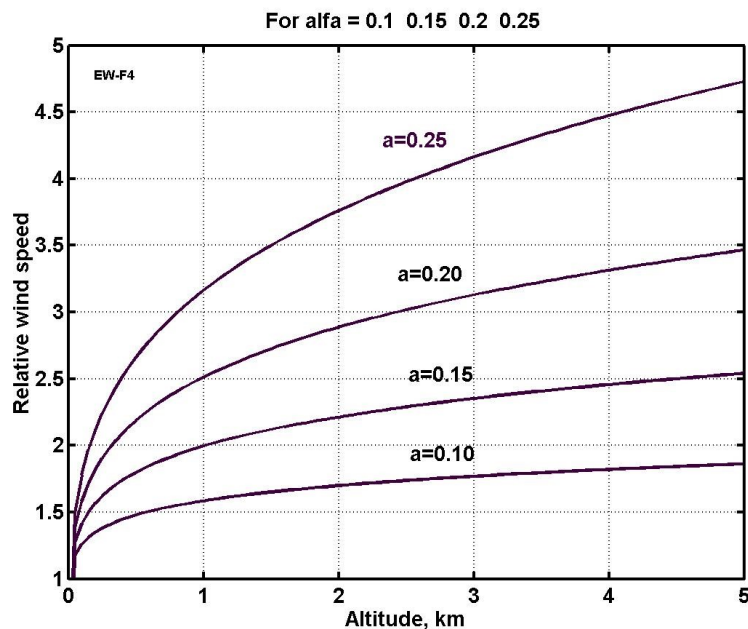


Fig. 12. Relative wind speed versus altitude for  $V_o = 6$  m/s,  $H_o = 10$  m/s.

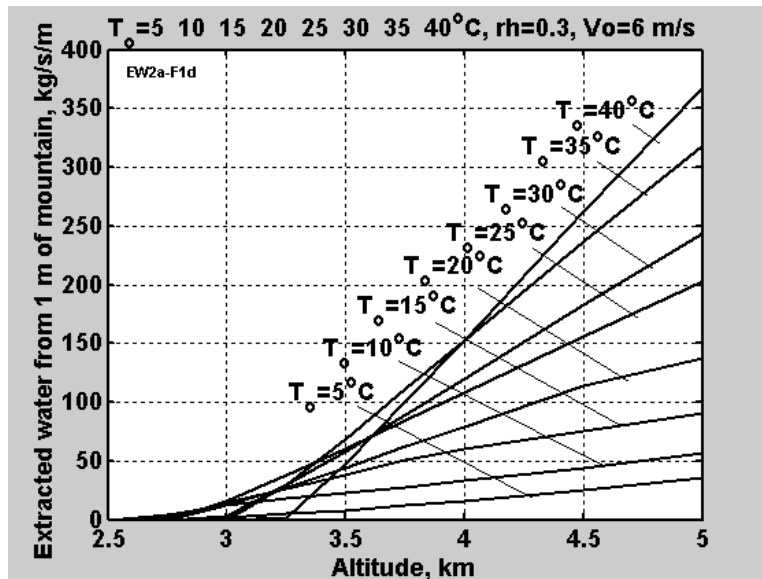
**4. Water produced by AB-Wall.** Each linear meter of the Wall ridge (which may stretch for 5 km, 100 km, or even more) produces the water

$$W(H_m) = k_c V_0 \int_0^{H_m} m_w(T, H_m, h) \bar{\rho}(H) \bar{V}(H) dH$$

where  $m_w = 0.00625[p(T_0)h - p(H_m)]$ , for  $m_w > 0$ , (4)  
 if  $m_w < 0$ , than  $m_w = 0$ .

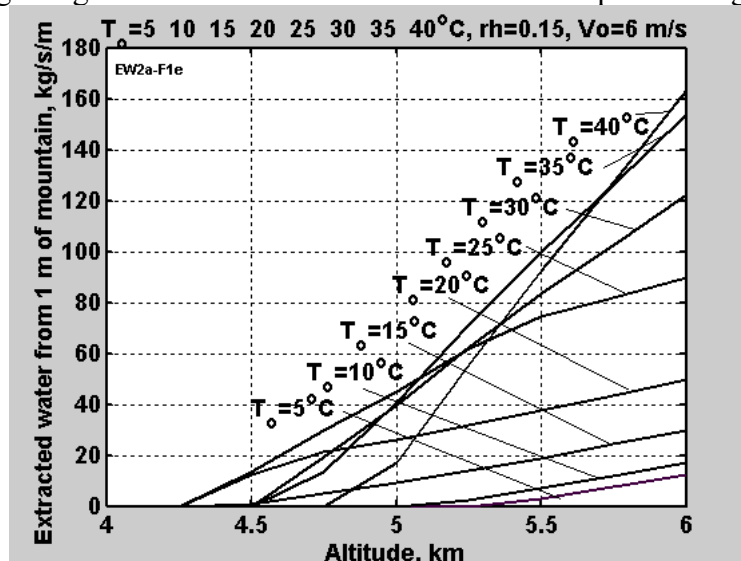
where  $W$  is water flow produced by 1 m of Wall ridge, kg/s/m;  $m_w$  is water in 1 m<sup>3</sup> [kg/m<sup>3</sup>];  $H_m$  is maximal height of artificial Wall, m;  $k_c = 0.5 \div 1$  is collector (extraction) coefficient;  $h \approx 0.5 \div 1$  is air humidity;  $V_0$  is wind speed at  $H = 0$ , m/s.

The computations of the equation (4) for  $h = 0.3$ ,  $k_c = 1$ ,  $V_0 = 6$  m/s are presented in fig. 13.



**Fig. 13.** Amount of water flow may be extracted by 1 m of the AB-Wall (rain and wall) via wall height for different air temperature  $T_0$  at  $H_0 = 10$  m, air speed  $V_0 = 6$  m/s, relative air humidity  $rh = 0.3$  at sea level. Collector efficiency  $k_c = 1$ , coefficient increasing of air speed with altitude  $\alpha = 0.15$ ;  $H_m = 5$  km. The part of this water is realized as rain before Wind Wall and part is precipitations on wall surface ( $k_c < 1$ ).

Please notice: If relative humidity is  $rh = 0.3$ , the Wall begins to produce water over altitude 3 km. Every 100 - 300m ridge length of a 5-km altitude artificial Wall can produce a good sized river.



**Fig. 14.** Amount of water flow may be extracted by 1 m of the AB-Wall via wall height for different air temperature  $T_o$  at  $H_o = 10$  m, air speed  $V_o = 6$  m/s, relative air humidity  $rh = 0.15$  at sea level. Collector efficiency  $k_c = 1$ , coefficient increasing of air speed with altitude  $\alpha = 0.15$ ;  $H_m = 6$  km.

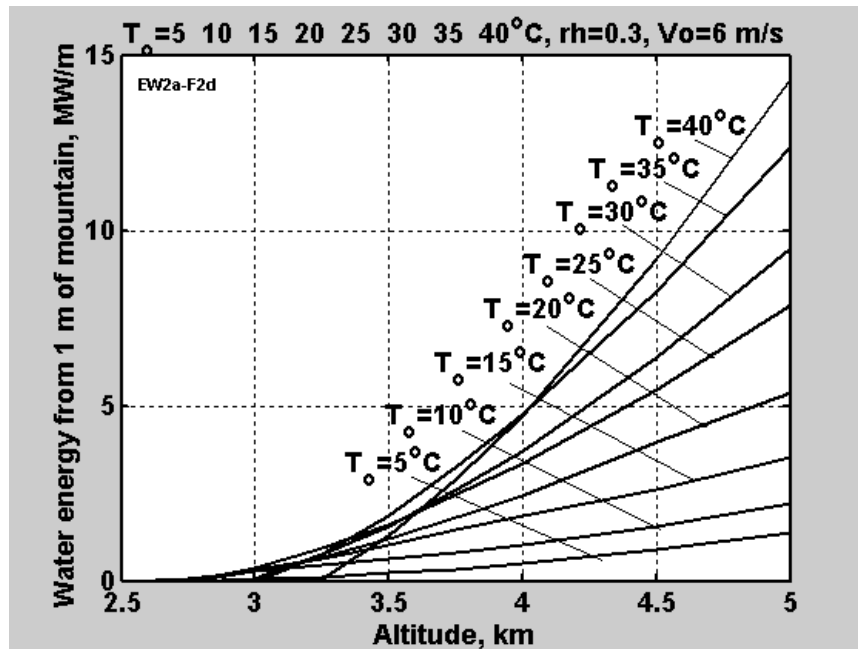
The total water carried as vapor by atmospheric air is significantly more than we have here extracted. The perfect design of a water collector increases the extraction coefficient  $k_c$ . The computation of total water flow (for  $k_c = 1$ ) is presented in fig.16. The water non-extracted from atmosphere goes as clouds and rain after crossing the Wall ridge.

**5. Energy produced by high altitude water.** The water condensed at high altitude has huge energy because it has great mass and is located advantageously at very high altitude. For example, if artificial Wall has a height = 5 km, the water pressure at sea level is about 500 atm. We can easily convert this energy into electricity by conventional hydro-turbine and electric generators. And the higher the pressure, the smaller the installation needed.

Equation is below:

$$P = g\eta WH_m, \quad (5)$$

where  $P$  is water power, W/m;  $g = 9.81$  m/s<sup>2</sup>;  $\eta$  is efficiency coefficient;  $W$  is water flow, kg/s/m; (Eq. (4));  $H_m$  is maximal altitude, m. The result equation is in fig. 15.



**Fig. 15.** Water energy (MW) from 1 m of AB-Wall via wall height and air temperature  $T_o$ , air speed  $V_o = 6$  m/s, relative air humidity  $rh = 0.3$  at sea level  $H = 10$  m. Collector efficiency  $k_c = 1$ , product of efficiency coefficients (tubes, hydro-turbine, electric generator) is  $\eta = 0.8$ , coefficient increasing of air speed with altitude  $\alpha = 0.15$ . The real energy may be less in two times because a part of water drop out as rain before Wall ( $k_c = 0.5$ ).

Again, please notice: That the artificial AB-Walls produce gigantic levels of energy. A conventional large hydro-electric power station such as Hoover Dam may have about 2 GW of generating capacity. Only 4 km ridge length of 5 km tall artificial AB-Wall can potentially produce energy comparable to the largest conventional hydroelectric stations in the world, in China and Brazil. (See for comparison [http://en.wikipedia.org/wiki/List\\_of\\_the\\_largest\\_hydroelectric\\_power\\_stations](http://en.wikipedia.org/wiki/List_of_the_largest_hydroelectric_power_stations)) (And, most

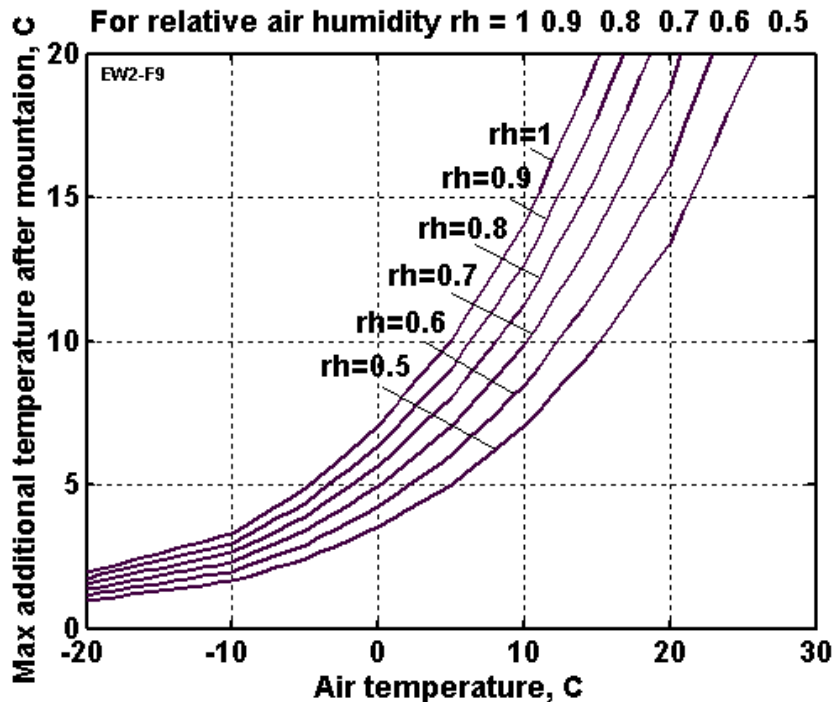
importantly, the AB-Wall does not silt up its' reservoirs like a conventional dam does.) The huge amount of green water energy may be the most important profit potential obtainable from the offered AB-Wall.

**6. Wall – derived warm wind.** The water vapor condensing to water produces a lot of energy, about 2260 kJ/kg of water. The atmosphere absorbs this energy. The ground air temperature in the lee of the Wall is more than it is upwind of the Wall. The increase of air temperature may be estimated by equation received from equation of heat balance:

$$\Delta T = \frac{k_c \lambda m_{w0}(T_0)h}{c_p \rho_0}, \quad m_{w0} = 0.00625 p(T_0), \quad (6)$$

where  $\Delta T$  is additional atmospheric temperature, C;  $k_c \approx 0.7 - 1$  is extraction coefficient,  $m_{w0}$  is amount of water in 1 m<sup>3</sup> of air at temperature  $T_0$ , kg/m<sup>3</sup> (see Table 1);  $h \approx 0.5 - 1$  is humidity;  $c_p \approx 1$  kJ/kg/C is average air heat capability;  $\rho_0 = 1.225$  kg/m<sup>3</sup> is standard air density. Note, the artificial Wall works better than a natural Wall because one has a smooth surface and good, indeed, selectable aerodynamic form (semicylinder).

The computations for  $k_c = 1$  are presented in fig.16.



**Fig.16 .** Maximal additional heating of atmosphere after Wall via temperature before Wall and relative humidity. Condenser coefficient equals 1.

As you see the artificial Wall can significantly increase temperatures of cold polar-derived winds. For example, if atmospheric temperature was 0 C, after an encounter with an artificial Wall it may be up to 7 C. If the initial air temperature was 10 C, after artificial Wall it may be up to 24 C. This effect is good relief for cold countries (Iceland-Scandinavia-Russia-Siberia, Canada, USA-Alaska), but it is not well for a hot area (Sahara). The cold water from AB-Wall may be used for cooling the buildings of a city located behind the artificial Walls. On the other hand, in the desert, we may place a new city before the Walls for wind cooling, and salt drying ponds behind the Walls, for free accelerated air-drying! Near the Red Sea, for example, 2.4 meters a year of salt water may evaporate from salt ponds.



Such a rate could easily be doubled with hotter winds blowing for much of the time, doubling annual salt production.

Gigantic streams of energy flow through AB-Wall ranges. If AB-Wall length is 100 km only, water vapor power and air kinetic power is

$$P_v = c_{pm}SV\Delta T, \quad P_k = 0.5MV^2, \quad M = \rho VS, \quad (7)$$

where  $P_v$  is water vapor power, W;  $P_k$  is air kinetic power, W;  $c_{om} = 1.287 \text{ kJ/m}^3\text{K}$  for air is the heat coefficient;  $V$  – average air speed, m/s;  $M$  – air flow mass, kg/s;  $S$  – cross-section of air flow,  $\text{m}^2$ ;  $\rho$  – average air density,  $\text{kg/m}^3$ . If Wall ridge is only 100 km,  $V = 5 \text{ m/s}$  and  $\Delta T = 10 \text{ C}$  the water vapor power has gigantic value  $(1 - 3) \times 10^7 \text{ MW}$  (10,000 one gigawatt power electric stations). The kinetic air power is only  $\approx 2 \times 10^4 \text{ MW}$ . ( $2 \times 10$  gigawatts)—which is logical, because water is about a thousand times denser than air! But look at those figures—the whole energy use of mankind today is only  $\sim 13,000$  gigawatts! So a AB-Wall range can actually generate the energy that all mankind uses today, at an amazingly realistic cost (see below).

The control (of height, reflectivity, and position) of the AB-Wall range manages this gigantic natural flow of energy and changes the weather and climate around the artificial Wall.

**7. Wind energy.** The AB-Wall has a high crest where there is a strong permanent wind. If we install the windmills at the top of AB-Wall, we get energy. This energy may be estimated by equations

$$N_1 = 0.5\eta\rho(H)D \cdot (\bar{V}V_0)^3, \quad (8)$$

where  $N_1$  is windmill power from 1 m of the Wall ridge, W/m;  $\eta = 0.3 \div 0.6$  is coefficient efficiency of wind rotor,  $\rho$  is air density at altitude  $H$ ;  $D$  is rotor diameter, m;  $V$  is wind speed (see early), m/s.

Computations are presented in fig. 17.

As you see (compare with fig. 15) the wind energy in 500 times is less then the water energy and no reasons to install the complex and expensive windmills at top of AB-Wall. But they may be useful on the low wall, which doesn't produce the water.

**8. Cooling of buildings in hot weather.** The water from Wall top has temperature about  $0^\circ\text{C}$ . That may be used for cooling of cities through cold fountains, cooling of buildings, dwelling, food storage in hot countries, even growing non-tropical crops in tropical countries! That can save much energy spent by conditions in summer time in hot weather. This energy may be estimated by expression:

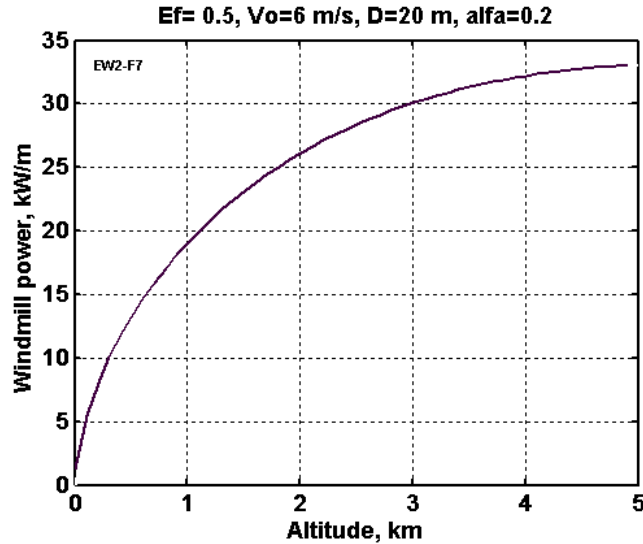
$$Q_1 = c_pWT_0 / \eta_c, \quad (9)$$

where  $Q_1$  is possible energy from 1 m of AB-Wall, W/m;  $c_p = 4.19 \text{ kJ/kg K}$  is water heat capability;  $T_0$  is air temperature at  $H = 0$ , C;  $W$  is water flow, kg/s/m;  $\eta_c \approx 0.3$  is coefficient efficiency of condition.

*Example.* Let us to estimate the energy from cold water relative to the warm atmosphere. Assume the air temperature  $T_a = 35 \text{ C}$ , the water temperature is  $0 \text{ C}$ , but while the water moves into delivery tubes, that warms approximately up  $T_w = 5 \text{ C}$ . That means  $T_0 = 35 - 5 = 30 \text{ C}$ . From fig. 15 we have the water flow  $W = 300 \text{ kg/m}$  for  $T = 35 \text{ C}$ . The total energy (for  $\eta_c = 1$ ) is (Eq.(9))  $Q_1 = 38 \text{ MW/m}$ . That is 3 times more than the energy from high altitude water ( $P = 12 \text{ MW/m}$ , fig.15). The efficiency of condition is  $\eta_c \approx 0.3$  and a comfortable room temperature  $T_r = 25 \text{ C}$ . If we substitute these values (difference between air temperature and room temperature,  $T_0 = T_r - T_w = 25 - 5 = 20 \text{ C}$ ) in Eq. (8), we may to save electric energy spent by air conditioners up to  $Q_1 = 84 \text{ MW/meter}$  of Wall ridge. That is 7 times more then energy from high altitude water.

The cooling energy in some times more then  $P$  [Eq. (4)]. But that is difficult to realize in practice (except for cooling needs) because the difference of temperatures between water and air is small ( $\approx 20 \text{ C}$ ). The cold water for cooling of building may be delivered by current water (heat transfer) systems. An on-land version of OTEC technology using solar hot water heaters and the cold water to maximize the temperature differences might tap these energy streams, but why? The hydroelectricity is far

cheaper and less capital intensive. One use of such masses of cold water might be to lower the temperature of bodies of water to better hold oxygen for productive aquaculture.



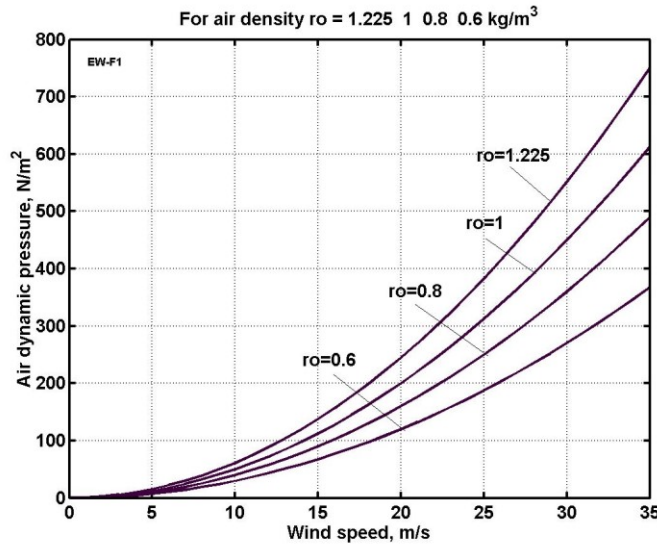
**Fig. 17.** Windmill power [kW/m] via Wall height for air speed  $V_o = 6$  m/s at sea level  $H_o = 10$  m, product of efficiency coefficients (windmill, electric generator) is  $\eta = 0.5$ , coefficient increasing of air speed with altitude  $\alpha = 0.2$ , diameter of wind turbine  $D = 20$  m.

**9. The wind dynamic pressure** is computed by equation

$$p_d = q = \frac{\rho V^2}{2}, \tag{10}$$

where  $p_d$  is wind dynamic pressure, N/m<sup>2</sup>;  $\rho$  is air density, for altitude  $H = 0$  the  $\rho = 1.225$  kg/m<sup>3</sup>;  $V$  is wind speed, m/s. The computation is presented in fig.18.

The small overpressure of 0.01 atm forced into the AB-Wall or AB-Wall to inflate it produces force  $p = 1000$  N/m<sup>2</sup>. That is greater than the dynamic pressure of very strong wind  $V = 35$  m/s (126 km/hour). If it is necessary we can increase the internal pressure by some times if needed for very exceptional storms.



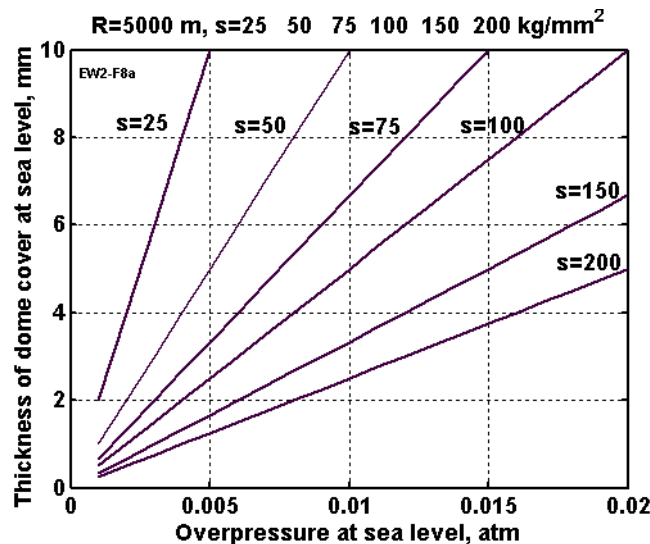
**Fig. 18.** Wind dynamic pressure versus wind speed and air density  $\rho$ . The  $\rho = 0.6$  is for  $H \approx 6$  km.

**10. The thickness and mass of the Wall envelope**, its sheltering shell of film, is computed by formulas (from equation for tensile strength):

$$\delta_1 = \frac{Rp\bar{p}}{2\sigma}, \quad \delta_2 = \frac{Rp\bar{p}}{\sigma}, \quad M = \gamma\delta S, \quad (11)$$

where  $\delta_1$  is the film thickness for a spherical Wall, m;  $\delta_2$  is the film thickness for a cylindrical Wall, m;  $R$  is radius of Wall (or Wall cover between the support cable [1]), m;  $p$  is wind (dynamic) pressure on the Wall ( $10 \div 100$ ),  $\text{N/m}^2$ ;  $\sigma$  is safety tensile stress of film (up to  $2 \times 10^9$ ),  $\text{N/m}^2$ ;  $M$  is wall mass, kg;  $\gamma$  is specific density of fabric (film),  $\text{kg/m}^3$ ;  $S$  is full area of wall,  $\text{m}^2$ .

*Example:* If average difference between dynamic pressure and film mass is  $p\bar{p} = 100 \text{ N/m}^2$ ,  $R = 5000 \text{ m}$  and  $\sigma = 100 \text{ kg/mm}^2 = 10^9 \text{ N/m}^2$ ,  $\gamma = 1500 \text{ kg/m}^3$  the request film thickness is  $0.5 \text{ mm}$ , mass  $M = 0.75 \text{ kg/m}^2$ .



**Fig. 19.** Thickness of AB-Wall cover (without the support cables) via over pressure at  $H = 0$  for different safety stress. Radius of AB-Wall is  $R = 5 \text{ km}$ .

**11. Cost of freshwater extractor.** The cost,  $C$  [\$/kL], of produced freshwater may be estimated by the equation:

$$C = \frac{C_i / l + M_e}{M_{wy}}, \quad (12)$$

where  $C_i$  is cost of installation;  $l$  is live time of installation ( $l \approx 10$ ), years;  $M_e$  is annual Walls;  $M_{wy}$  is annual amount of received freshwater, kL.

The retail cost of electricity for individual customers is \$0.18 per kWh at New York in 2007. Cost of other energy from other fuel is in [8] p.368. Average cost of water from river is \$0.49 - 1.09/kL in the USA, the water produced from sea costs about \$.5-2/kL in Israel.

The estimations are in Project section.

**12. Energy requested by different methods of desalination.** Below in Table 3 is some data about expense of energy for different methods.

**Table 3.** Estimation of energy expenses for different methods of freshwater extraction

No	Method	Condition	Expense kJ/kL
----	--------	-----------	------------------

1	Evaporation	Expense only for evaporation*	$2.26 \times 10^6$
2	Freezing	Expense only for freezing, c.e. $\eta = 0.3$	$1 \times 10^6$
3	Reverse osmosis	Expense only for pumping, 40 ÷ 70 atm	$(4 \div 7) \times 10^3$

\* This expense may be decreased by 2 -3 times when the water installation is connected with heat or nuclear electric station.

The AB-Wall produces free freshwater and gives very cheap energy.

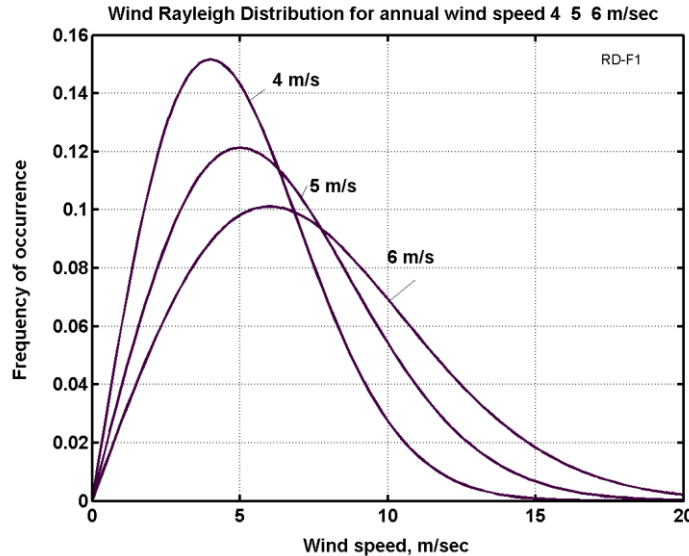
**13. Annual Wind speed distribution.** Annual speed distributions vary widely from one site to another, reflecting climatic and geographic conditions. Meteorologists have found that Weibull probability function best approximates the distribution of wind speeds over time at sites around the world where actual distributions of wind speeds are unavailable. The Rayleigh distribution is a special case of the Weibull function, requiring only the average speed to define the shape of the distribution.

Equation of Rayleigh distribution is

$$f_x(x) = \frac{x}{\alpha^2} \exp\left[-\frac{1}{2}\left(\frac{x}{\alpha}\right)^2\right], \quad x \geq 0, \quad E(X) = \sqrt{\frac{\pi}{2}}\alpha, \quad Var(X) = \left(2 - \frac{\pi}{2}\right)\alpha^2, \quad (13)$$

where  $\alpha$  is parameter.

Fig.22 presents the annual wind distribution of average speeds 4, 5, and 6 m/s. Special table [19] gives Rayleigh Wind Speed Distribution for Annual Average Wind Speed in m/s. These data gives possibility to easy calculate the amount (percent) days (time) when Wind Wall can operate in year (example, fig.23). It is very important value for the estimation efficiency of offered devices.



**Fig. 20.** Wind speed distribution for different average wind speed (4, 5, 8 m/s).

Let us compute *example*:

Assume, the Wind Wall has minimum admissible wind speed 3 m/s, maximum admissible speed 25 m/s, altitude 100 m, the average annual speed in given region is 6 m/s. From Table [19] and fig. 3, 20, 21, Eq. (3), we can get the wind speed is 8.4 at  $H = 100$  m, the probability that the wind speed will be less the 2 m/s is 8%, less 3 m/sec is 15%, the probability that the wind speed will be more 25 m/s is closed to 0.

Remain: At high altitude the wind is stability and powerful in some times.

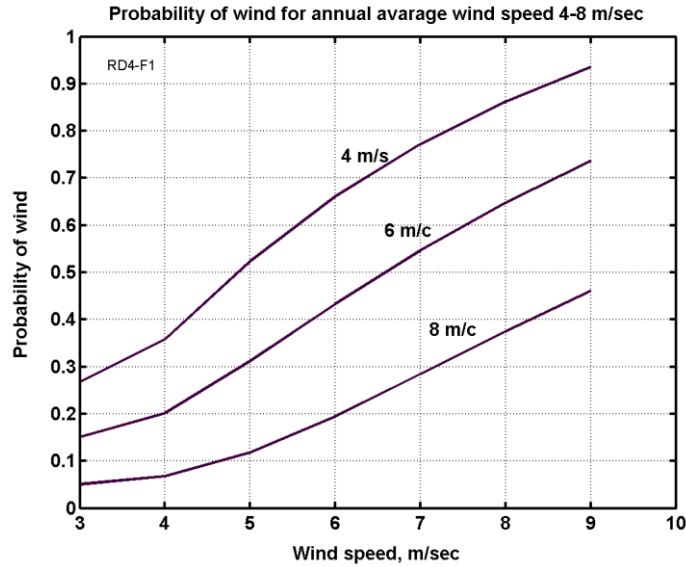


Fig. 21. Probability of wind at sea level for different average wind speed.

**14. Lift Force and Drag of Wind Wall.** Average lift force and drag of WW may be computed by equation

$$L = \frac{\rho V^2}{2} S_L, \quad D = \frac{\rho V^2}{2} S_D \quad (14)$$

or  $L = q S_L, \quad D = q S_D,$  where  $q = \frac{\rho V^2}{2}$

Here  $L$  - lift force [N];  $D$  - drag [N];  $\rho$  - average air density, if altitude  $H$  closed to 0  $\rho = 1.225 \text{ kg/m}^3$ ;  $V$  - wind speed [m/sec];  $S_L$  - is projection of Wall to horizontal plate, [ $\text{m}^2$ ];  $S_D$  is projection of Wall to vertical plate, [ $\text{m}^2$ ].

For Wind Wall of large size and height there force are very large. For example, one meter of Wall ridge having 5 km height has average  $q = 16 \text{ N/m}^2$ ,  $L = D = 8 \times 10^4 \text{ N/m}$ , when average wind speed equals  $V = 6 \text{ m/s}$ .

When designer know load, admissible wind speed, altitude, and fiber stress, he can estimate the necessary fabric (film) thickness, needed number of lift holes, film mass and its cost.

*Example* of some estimation. Let us estimate the lift force, drag and mass of one meter ridge of 5 km wall. If height of wall is 5 km ( $\rho = 0.75 \text{ kg/m}^3$ ), the average high altitude wind speed is  $V = 20 \text{ m/s}$ , the dynamic pressure is  $q = 150 \text{ N/m}^2$ , the  $L = D = 7.5 \times 10^5 \text{ N/m}$ . The mass of film having thickness  $\delta = 1 \text{ mm}$  and density  $\gamma = 1500 \text{ kg/m}^3$  is  $M = 11.7 \times 10^3 \text{ kg/m}$ .

The additional lift force produced by lift holes (in lower part of wall) having size  $l_h = 1 \text{ m}$  (fig. 4) and width 1 m may be estimated by equation

$$\Delta L = n q l_h, \quad (14a)$$

where  $n$  is total number of lift holes in 1 m of wall ridge. Example: if  $n = 300$ ,  $q = 54 \text{ N/m}^2$ , the additional lift force equals 16200 N/m.

It is difficult to get need lift force for very high (5 km) wind wall in a low wind speed.

That way the offered wall is more suitable as the protection wall against the small rockets (up 2 km). Unfortunately this wall will protect only in wind weather.

**15. Cable Mass.** Cable mass can be computed by equation:

$$M = l \frac{\gamma}{\sigma} F, \quad (15)$$

where  $M$  - mass of cable (fiber) [kg];  $l$  - length of cable [m];  $\gamma$  - cable density [ $\text{kg}/\text{m}^3$ ];  $\sigma$  - cable stress [ $\text{kg}/\text{m}^2$ ];  $F$  - tensile force [N]. Example: If  $l = 10$  km,  $\gamma = 1500$   $\text{kg}/\text{m}^3$ ,  $\sigma = 1.5 \times 10^9$   $\text{N}/\text{m}^2$ ,  $F = 4 \times 10^5$  N/m, the cable mass is  $M = 4000$  kg/m.

**16. Diameter of the Cable.** Diameter of cable (fiber),  $d$ , may be computed by equation

$$d = 2 \sqrt{\frac{F}{\pi \sigma}} \quad (16)$$

**17. Using the AB-Wall for tourism, communication and wind energy.**

The relatively low AB-Wall can give good profit from tourism. As it shown in [9] p.93 for 4800 tourists in day and ticket cost \$9 the profit would be about \$15 million/year. (They would go for the sweeping horizon-to horizon view of a vast terrain kilometers below)

The profit may be from communication (TV, cell-telephone, military radars, etc). The best profit would be from wind electric station [14].

**18. Artificial fiber and cable properties** [22]-[25]. Cheap artificial fibers are currently being manufactured, which have tensile strengths of 3-5 times more than steel and densities 4-5 times less than steel. There are also experimental fibers (whiskers) that have tensile strengths 30-100 times more than steel and densities 2 to 5 times less than steel. For example, in the book [22] p.158 (1989), there is a fiber (whisker)  $C_D$ , which has a tensile strength of  $\sigma = 8000$   $\text{kg}/\text{mm}^2$  and density (specific gravity) of  $\gamma = 3.5$   $\text{g}/\text{cm}^3$ . If we use an estimated strength of 3500  $\text{kg}/\text{mm}^2$  ( $\sigma = 7 \cdot 10^{10}$   $\text{N}/\text{m}^2$ ,  $\gamma = 3500$   $\text{kg}/\text{m}^3$ ), than the ratio is  $\gamma/\sigma = 0.1 \times 10^{-6}$  or  $\sigma/\gamma = 10 \times 10^6$ . Although the described (1989) graphite fibers are strong ( $\sigma/\gamma = 10 \times 10^6$ ), they are at least still ten times weaker than theory predicts. A steel fiber has a tensile strength of 5000 MPA (500  $\text{kg}/\text{sq.mm}$ ), the theoretical limit is 22,000 MPA (2200  $\text{kg}/\text{mm}^2$ ) (1987); polyethylene fiber has a tensile strength 20,000 MPA with a theoretical limit of 35,000 MPA (1987). The very high tensile strength is due to its nanotube structure [25].

Apart from unique electronic properties, the mechanical behavior of nanotubes also has provided interest because nanotubes are seen as the ultimate carbon fiber, which can be used as reinforcements in advanced composite technology. Early theoretical work and recent experiments on individual nanotubes (mostly MWNT's, Multi Wall Nano Tubes) have confirmed that nanotubes are one of the stiffest materials ever made. Whereas carbon-carbon covalent bonds are one of the strongest in nature, a structure based on a perfect arrangement of these bonds oriented along the axis of nanotubes would produce an exceedingly strong material. Traditional carbon fibers show high strength and stiffness, but fall far short of the theoretical, in-plane strength of graphite layers by an order of magnitude. Nanotubes come close to being the best fiber that can be made from graphite.

For example, whiskers of Carbon nanotube (CNT) material have a tensile strength of 200 Giga-Pascals and a Young's modulus over 1 Tera Pascals (1999). The theory predicts 1 Tera Pascals and a Young's modulus of 1-5 Tera Pascals. The hollow structure of nanotubes makes them very light (the specific density varies from 0.8  $\text{g}/\text{cc}$  for SWNT's (Single Wall Nano Tubes) up to 1.8  $\text{g}/\text{cc}$  for MWNT's, compared to 2.26  $\text{g}/\text{cc}$  for graphite or 7.8  $\text{g}/\text{cc}$  for steel). Tensile strength of MWNT's nanotubes reaches 150 GPa.

Specific strength (strength/density) is important in the design of the systems presented in this paper; nanotubes have values at least 2 orders of magnitude greater than steel. Traditional carbon fibers have a specific strength 40 times that of steel. Since nanotubes are made of graphitic carbon, they have good resistance to chemical attack and have high thermal stability. Oxidation studies have shown that the onset of oxidation shifts by about  $100^0$  C or higher in nanotubes compared to high modulus graphite fibers. In a vacuum, or reducing atmosphere, nanotube structures will be stable to any practical service temperature (in vacuum up  $2800^0$  C. in air up  $750^0$  C).

In theory, metallic nanotubes can have an electric current density (along axis) more than 1,000 times greater than metals such as silver and copper. Nanotubes have excellent heat conductivity along axis up 6000  $\text{W}/\text{m.K}$ . Copper, by contrast, has only 385  $\text{W}/\text{m.K}$ .

About 60 tons/year of nanotubes are produced now (2007). Price is about \$100 - 50,000/kg. Experts predict production of nanotubes on the order of 6000 tons/year and with a price of \$1 – 100/kg to 2012.

Commercial artificial fibers are cheap and widely used in tires and countless other applications. The authors have found only older information about textile fiber for inflatable structures (Harris J.T., Advanced Material and Assembly Methods for Inflatable Structures, AIAA, Paper No. 73-448, 1973). This refers to DuPont textile Fiber **B** and Fiber **PRD-49** for tire cord. They are 6 times strong as steel (psi is 400,000 or 312 kg/mm<sup>2</sup>) with a specific gravity of only 1.5. Minimum available yarn size (denier) is 200, tensile module is 8.8×10<sup>6</sup> (**B**) and 20×10<sup>6</sup> (**PRD-49**), and ultimate elongation (percent) is 4 (**B**) and 1.9 (**PRD-49**). Some data are in Table 4.

**Table 4.** Material properties

Material	Tensile strength kg/mm <sup>2</sup>	Density g/cm <sup>3</sup>	Fibers	Tensile strength kg/mm <sup>2</sup>	Density g/cm <sup>3</sup>
Whiskers					
AlB <sub>12</sub>	2650	2.6	QC-8805	620	1.95
B	2500	2.3	TM9	600	1.79
B <sub>4</sub> C	2800	2.5	Allien 1	580	1.56
TiB <sub>2</sub>	3370	4.5	Allien 2	300	0.97
SiC	1380-4140	3.22	Kevlar or Twaron	362	1.44
<b>Material</b>			Dynecta or Spectra	230-350	0.97
Steel prestressing strands	186	7.8	Vectran	283-334	0.97
Steel Piano wire	220-248		E-Glass	347	2.57
Steel A514	76	7.8	S-Glass	471	2.48
Aluminum alloy	45.5	2.7	Basalt fiber	484	2.7
Titanium alloy	90	4.51	Carbon fiber	565	1,75
Polypropylene	2-8	0.91	Carbon nanotubes	6200	1.34

Source: [22]-[25]. Howatson A.N., Engineering Tables and Data, p.41.

Industrial fibers have up to  $\sigma = 500 - 600 \text{ kg/mm}^2$ ,  $\gamma = 1500 - 1800 \text{ kg/m}^3$ , and  $\sigma/\gamma = 2,78 \times 10^6$ . But we are projecting use in the present projects the cheapest films and cables applicable (safety  $\sigma = 100 - 200 \text{ kg/mm}^2$ ). The basalt fiber costs about 0.7 \$/kg (USD)(2007).

## Projects

### 1. AB-Wall ridge of height 5 km and length 100 km

Let us estimate the parameters, cost and profit of a system of AB-Walls. Ridge of the height  $H = 5$  km and length  $L = 100$  km having simple primary cover (without control of transparency). Take the safety tensile stress of cover  $\sigma = 100 \text{ kg/mm}^2$  ( $10^9 \text{ N/m}^2$ ), specific weight of cover  $\gamma = 1500 \text{ kg/m}^3$ , average wind speed at sea level  $V = 6 \text{ m/s}$ , air humidity  $rh = 0.3$ .

**Main cost of AB-Wall.** We take the average cover thickness  $\delta = 3 \text{ mm}$ . The weight of  $S = 1 \text{ m}^2$  cover is  $w = \sigma\gamma S = 4.5 \text{ kg/m}^2$ . The length of Wall semi-cylinder  $L_r = \pi R/2 = 0.78 \times 10^4 \text{ m}$ , the weight of 1 m Wall length is  $W_l = wL_r = 3.5 \times 10^4 \text{ kg/m}$ .

If cost of 1 kg cover is \$1, then the cost of 1 m of the Wall cover is \$35,000/meter). We take the **total** cost of 1 m Wall length (1 m of ready-made Wall Installation)  $c_d = \$50,000/\text{meter}$  or \$50 million/km. In this case the total cost of  $L = 100$  km AB-Wall Installation is  $C_d = c_d L = \$0.5 \times 10^{10} = \mathbf{\$5 B}$  (where B is billion dollars). If maintenance is \$1000/m/year, the total maintenance is \$100M/year (where M means million). The cost of cover is the main component in the AB-Wall. The film may be reinforced by strong cheap artificial transparency fiber and this textile material will have very high tensile stress. The life time of the cover is about 10 years. (\$0.5 billion a year must be set aside for replacing it).



**Profit from AB-Wall.**

a) *Profit from sale of electricity.* Let us take the average annual temperature outside of Wall  $T_0 = 25$  C. From fig.17 we find the average power of electricity is  $P = 7$  MW/m. The Wall length is  $100\text{km} = 10^5\text{m}$ . The total power is  $7 \times 10^6 \times 10^5 = 7 \times 10^{12}$  W = 7 TW. The total (include oil, gas, coal, etc.) World Power usage was about 14 TW in 2005 (all World hydro-station has power only 0.3 TW). The year contains  $t = 24 \times 365 = 8,760$  hours. Annual energy of 1 m Wall is  $E_1 = tP = 6.1 \times 10^7$  kWh/year/m. (61 trillion kWh yearly).

Retail cost of electric energy in New York is \$0.18 1/kWh. We take price  $c_1 = \$0.1$  1/kWh. The profit from electricity of energy is  $C_1 = c_1 E_1 = \$6.1\text{M/year/m}$ . The length of Wall is  $L = 10^5$  m. The total annual profit only from electricity is  $C_e = C_1 L = \mathbf{\$610\text{ B/year}}$ . *That is ~ 122 times more than the cost of the AB-Wall installation.*

(In reality, of course, increased supply usually decreases prices; but even at \$.01 a kilowatt hour, the equivalent of coal at \$82 a ton or gas at under \$3 per thousand cubic feet, the income of \$61 billion would pay back the costs of construction (of the Wall, not the hydro works) in *only two months!* And at half even this price, or a half-cent a kilowatt-hour, the cleanness and controllability of hydroelectricity would seriously start to displace carbon fuels, in the sense that even coal and gas would have difficulty competing as simple thermal sources. So an interesting initiative for peace in the Mediterranean area would be the EU financing such an AB-Wall, the EU taking the power and the desert areas to the south taking the water.)

The actual profile of the available water may be distributed around the year, depending on when prevailing winds cause a local 'rainy season'

b) *Profit from sale of water.* For temperature  $T_0 = 25$  C the water flow from 1 m Wall is  $q = 0.17$  m<sup>3</sup>/s/m,  $1\text{m}^3 = 1\text{kL}$  (fig. 15). Year has  $t = 24 \times 60 \times 60 \times 365 = 3.1536 \times 10^7$  s. The annual water from 1 m Wall is  $M_1 = qt = 5.35 \times 10^6$  kL/year/m. ( $5.35 \times 10^5 = 5.35 \times 10^{11}$  tonnes = 535 cubic kilometers of fresh water! It is worthy of note that the projected flow at these magnitudes constitutes a second Mississippi River, buildable on demand. (For comparison, the Egypt is only allowed to remove from the Nile, about 55.5 cubic kilometers per year ([http://www.eoearth.org/article/Water\\_profile\\_of\\_Egypt](http://www.eoearth.org/article/Water_profile_of_Egypt)). Thus, for \$27 billion a year, (buying externally) Egypt could double its available water. This is not likely at their current economic profile, (~92 billion GNP) but by selling the water, they could more than double the acreage farmed, buy enormously improved stability for the government (more employed males farming, vs. unemployed ones protesting) and thus is a politically favored outcome. If the Egyptian government were to build the AB-Wall rather than to buy from a foreign water vendor, for \$10 billion a year and \$1 billion a year maintenance it could produce and sell the water itself to farmers and use the revenue to pay for government employees in the cities. The annual water from 1 m Wall is  $M_1 = qt = 5.35 \times 10^6$  kL/year/m. If water cost is  $c = \$1/\text{kL}$  and length of Wall  $L = 10^5$  m, the total water profit from Wall will be  $C_w = \mathbf{\$536\text{ B/year}}$ . *That is in 17 times more than the cost of the installation.*

*The common annual income from electricity and water is \$1146 B/year. That is about 230 times more than the cost of the AB-Wall installation.*

Again, at one-twentieth or less these prices, (the likely price stagnation point) the AB-Wall abundantly repays its construction, and in fact cultivates huge new demand for carbon replacement power and water cheap enough to irrigate with.

c) *The profit from cooling of buildings.* In point 8 (Eq. (8)) we computed the example which shows that cooling water may saves  $Q_1 = 84$  MW/m electric energy spent by conditions. The year contains  $t = 24 \times 365 = 8,760$  hours. Annual energy of 1 m Wall is  $E_1 = tQ_1 = 7.34 \times 10^8$  kWh/year/m. If we sale this energy by price  $c_1 = \$0.05/\text{kWh}$  the profit is  $C_1 = c_1 E_1 = \$36.7\text{ M/year/m}$ . The length of Wall is  $L = 10^5$  m. The total annual income is  $C_e = C_1 L$  would theoretically = \$3670 B/year. *That is a benefit 730*

*times more than the cost of installation.* That income is problematical; therefore we do not take it into account. (The offered method of cooling is new and with great benefit but the poor tropical countries that need it most cannot yet pay for it. However, as a side benefit (i.e. cooling poor tropical countries such as India where extremes of 48 C (120 F) are not uncommon for weeks on end in summer, it could save many lives. It could also relieve inestimable human suffering and buy political peace with the poorest of the poor by giving them a real benefit from their country's decision to build an AB-Wall range. There are no technical problems in its application, the current water heat system may be used for cooling, and building cooling is very important problem for hot country or warm countries in hot summer weather).

d) *There are a lot of other possibilities* to get the profit from offered AB-Wall. For example, tourism at high altitude, communication, civil or/and military locators, fly gliding, cheap parachute jumping, non-gravity jumping, entertainments, etc. That can give additional profit.

As you see the AB-Wall may just qualify as the project in the World that best gives incomparable rates of return, earning its cost back and more in one year (every year!). Whoever does not agree, can do the numbers with their own assumptions, to check our own.

Naturally, any national or private investor would have many questions: For example, how to build this gigantic Wall. The author has many inventions, which solve these problems and is available for consulting to interested parties.

Remainder, our estimation data for this project is not yet optimized. For example, increasing the Wall height (up 1 km) significantly increases the energy (up to 50%) and yielded water. But such a modification increases the cost only 20%. Many such parameters can be tweaked for yet better results.

## DISCUSSION

As with any innovative macro-project proposal, the reader will naturally have many questions. Author offer brief answers to the four most obvious questions our readers are likely to ponder.

(1) *How can snow and ice be removed from the Wall?*

If water appears over film (rain), it flows down through a special tube into ground-based turbines. The top part of wall can be black color and heats by Sun. If snow (ice) appears a top the film, the vibration from wind moves them in slope wall surface to down. We also can temporary decrease the wall height.

(2) *Storm wind.*

The Wall has special valves in case a strong wind. We also can put down the Wall if we wait a storm.

(3) *Cover damage.*

The envelope contains a rip-stop cable mesh so that the film cannot be damaged greatly. Electronic signals alert supervising personnel of any rupture problems. The cover has internal and external cable (rope-ladders and rope cars, rope elevators) and workers can reach the any part of cover inside or out side for repair.

(4) *What is the design life of the film covering?*

Depending on the kind of materials used, it may be as much a decade (or up to 20 years and more). In all or in part, the cover can be replaced periodically.

(5) *How to build the AB-Wall?* The simplest method is to spread the section of cover on ground and wait a strong wind.

The author began this research as investigation of new methods for receiving the cheap freshwater from atmosphere [1]-[17]. In processing research, he discovered that method allows producing huge amount energy, in particular, by transferring the atmospheric energy into electricity with high

efficiency. The thin film (relative to volume contained, and absolutely) is very cheap. They are thrown out by the hundreds of tons every day and waste the environment, but properly employed they can conserve it as well. The theory of inflatable space towers [1]-[16] allows to build very cheap high height AB-Walls or towers, which can be used also for tourism, communication, radio-location, producing wind electricity, space research [1-16].

## 5. CONCLUSION

One half of Earth's population is malnourished. *The majority of Earth is not suitable for unshielded human life.* The offered AB-Walls can change the climate many regions, give them the water and energy. The increasing of agriculture area, crop capacity, carrying capacity by means of converting the deserts, desolate wilderness, taiga, permafrost into gardens are an important escape hatch from some of humanity's most pressing problems. The offered cheapest AB method may dramatically increase the potentially realizable sown area, crop capacity; indeed the range of territory suitable for human living. In theory, converting all Earth land such as Alaska, North Canada, Siberia, or the Sahara or Gobi deserts into prosperous garden would be the equivalent of colonizing an entire new planet. The suggested method is very cheap and may be utilized at the present time. We can start from small areas, such as small towns in bad regions and extended the practice over a large area—and what is as important, making money most of the way.

Film Walls can foster the fuller economic development of dry, hot, and cold regions such as the Earth's Arctic and Antarctic and, thus, increase the effective area of territory dominated by humans. The country can create the Wall barriers which will defense country from cold North winds. Normal human health can be maintained by ingestion of locally grown fresh vegetables and healthful "outdoor" exercise. The Walls can also be used in the Tropics and Temperate Zone. Eventually, they may find application on the Mars since a vertical variant, inflatable towers to outer space, are soon to become available for launching spacecraft inexpensively into Earth-orbit or interplanetary flights [12].

The related problems are researched in references [1]-[17].

Let us shortly summarize some advantages of this offered AB Wall method of climate moderation:

- (1) The artificial Walls give a lot of freshwater and energy and change a local climate (e.g convert a dry climate to damp climate);
- (2) They protect from cool or hot wind a large region;
- (3) Area does not need large amounts of constant input water for irrigation;
- (4) Low cost of inflatable film (fabric) Wall per area reclaimed;
- (5) Control of area temperature;
- (6) Usable in very hot and cool regions;
- (7) Protected area is not at risk from weather;
- (8) Possibility of flourishing crops even with a sterile soil (hydroponics);
- (9) Rich harvests, at that.
- (10) Converting deserts, desolate wilderness, taiga, tundra, permafrost, and ocean into good region;
- (11) Protection of towns, cities from small tactical rockets by offered Walls;
- (12) Using the high artificial Walls for tourism, communication, long location, and so on;
- (13) Using the Wall cover for illumination, pictures, films and advertising.

We can make fine local weather; get new territory for living with an agreeable climate without wind and low temperatures, and for agriculture. We can protect by Wind Wall gigantic expanses of bad dry and cold regions. The countries having big territory (but bad land) may be able to use to increase their population and became powerful states in the centuries to come.

The offered methods [1]-[17] may be used to conserve a vanishing sea as the Aral or Dead Sea. A closed loop water cycle saves this sea for a future generation, instead of bequeathing a salty dustbowl.

The author developed the same method for the ocean (sea). By controlling the dynamics and climate there, ocean colonies may increase the useful area another 3 times (after the doubling of useful land outlined above). All in all, this method would allow increasing the Earth's population by 5 – 10 times without starvation. The reader finds the useful data for computation in [18]-[26].

The offered method can solve the problem of global warming because AB Walls will be able to confine until use much carbonic acid (CO<sub>2</sub>) gas, which appreciably increases a harvest. This carbon will show up in yet more productive crops! The telephone, TV, electric, water and other communications can be suspended on the Wall cover.

The offered method can also help to defend the cities (or an entire given region) from small rockets. Details is offered in a paper [16].

### Acknowledgement

The author wishes to acknowledge Joseph Friedlander (Israel) for correcting the author's English and useful technical advices and suggestions.

### REFERENCES

- (The reader may find some of these articles at the author's web page: <http://Bolonkin.narod.ru/p65.htm>, <http://arxiv.org>, search "Bolonkin", in the book "*Non-Rocket Space Launch and Flight*", Elsevier, London, 2006, 488 pgs. and in books "*New Concepts, Ideas, Innovations in Aerospace, Technology and Human Science*", NOVA, 2008, 502 pgs., "*Macro Projects: Environment and Technology*", NOVA, 2009, 536 pgs.)
1. Bolonkin A.A., Cheap Artificial AB-Mountains, Extraction of Water and Energy from Atmosphere and Change of Regional Climate. <http://atxiv.org> search "Bolonkin".  
[online] <http://arxiv.org/ftp/arxiv/papers/0801/0801.4820.pdf>.
  2. Bolonkin, A.A. and R.B. Cathcart, Inflatable 'Evergreen' Dome Settlements for Earth's Polar Regions. Clean. Techn. Environ. Policy. DOI 10.1007/s10098.006-0073.4.
  3. Bolonkin A.A., Control of Regional and Global Weather. 2006. <http://arxiv.org> search for "Bolonkin".  
[online] <http://arxiv.org/ftp/physics/papers/0701/0701097.pdf>
  4. Bolonkin A.A., Cheap Textile Dam Protection of Seaport Cities against Hurricane Storm Surge Waves, Tsunamis, and Other Weather-Related Floods, 2006. <http://arxiv.org>.  
[online] <http://arxiv.org/ftp/physics/papers/0701/0701059.pdf>
  5. Bolonkin, A.A. and R.B. Cathcart, Antarctica: A Southern Hemisphere Windpower Station?  
<http://Arxiv.org>. 2007. <http://arxiv.org/ftp/physics/papers/0701/0701055.pdf>.
  6. Cathcart R.B. and Bolonkin, A.A. Ocean Terracing, 2006. <http://arxiv.org>.  
<http://arxiv.org/ftp/physics/papers/0701/0701100.pdf>
  7. Bolonkin, A.A. and R.B. Cathcart, The Java-Sumatra Aerial Mega-Tramway, 2006. <http://arxiv.org>.  
<http://arxiv.org/ftp/physics/papers/0701/0701099.pdf>
  8. Bolonkin, A.A., "Optimal Inflatable Space Towers with 3-100 km Height", *Journal of the British Interplanetary Society* Vol. 56, pp. 87 - 97, 2003.
  9. Bolonkin A.A., *Non-Rocket Space Launch and Flight*, Elsevier, London, 2006, 488 ps.
  10. Macro-Engineering: *A Challenge for the Future*. Springer, 2006. 318 ps. Collection articles.
  11. Bolonkin A.A., Cathcart R.B., Inflatable 'Evergreen' Polar Zone Dome (EPZD) Settlements, 2006.  
<http://arxiv.org> search "Bolonkin". <http://arxiv.org/ftp/physics/papers/0701/0701098.pdf>
  12. Bolonkin A.A., Inflatable Dome for Moon, Mars, Asteroids and Satellites, Presented as paper AIAA-2007-6262 by AIAA Conference "Space-2007", 18-20 September 2007, Long Beach. CA, USA.  
<http://arxiv.org/ftp/arxiv/papers/0707/0707.3990.pdf>.
  13. Bolonkin, A.A. and R.B. Cathcart, "A Cable Space Transportation System at the Earth's Poles to Support Exploitation of the Moon", *Journal of the British Interplanetary Society* 59: 375-380, 2006.



14. Bolonkin A.A., Utilization of Wind Energy at High Altitude, AIAA-2004-5705, AIAA-2004-5756, International Energy Conversion Engineering Conference at Providence., RI, Aug.16-19. 2004. USA. <http://arxiv.org> .  
<http://arxiv.org/ftp/physics/papers/0701/0701114.pdf> .
15. Bolonkin A.A., Optimal Solid Space Tower, AIAA-2006-7717. ATIO Conference, 25-27 Sept. 2006, Wichita, Kansas, USA. <http://arxiv.org> , search "Bolonkin".  
<http://arxiv.org/ftp/physics/papers/0701/0701093.pdf> .
16. Bolonkin A.A., (2007). Cheap Method of City Protection from Rockets and Nuclear Warheads.  
<http://arxiv.org> search "Bolonkin". <http://arxiv.org/ftp/arxiv/papers/0801/0801.1694.pdf>
17. Bolonkin, A.A., Irrigation without water (closed-loop water cycle). <http://arxiv.org> search "Bolonkin"(2007). <http://arxiv.org/ftp/arxiv/papers/0712/0712.3935.pdf> .
18. Naschekin, V.V., *Technical thermodynamic and heat transmission*. Public House for High Universities, Moscow. 1969 (in Russian).
19. Gleick, Peter; et al. (1996). in Stephen H. Schneider: *Encyclopedia of Climate and Weather*. Oxford University Press.
20. [Encyclopedia of Desalination and water and Water Resources](#). Springer.
21. [Encyclopedia of Earth - Surface water management](#). Springer.
22. Galasso F.S., *Advanced Fibers and Composite*, Gordon and Branch Scientific Publisher, 1989.
23. *Carbon and High Performance Fibers Directory and Data Book*, London-New. York: Chapman& Hall, 1995, 6<sup>th</sup> ed., 385 p.
24. *Concise Encyclopedia of Polymer Science and Engineering*, Ed. J.I. Kroschwitz, N. Y., Wiley, 1990, 1341 p.
25. Dresselhaus, M.S., *Carbon Nanotubes*, Springer, 2000.
26. Wikipedia. <http://wikipedia.org> . Some background material in this article is gathered from Wikipedia under the Creative Commons license.





# Chapter 7B

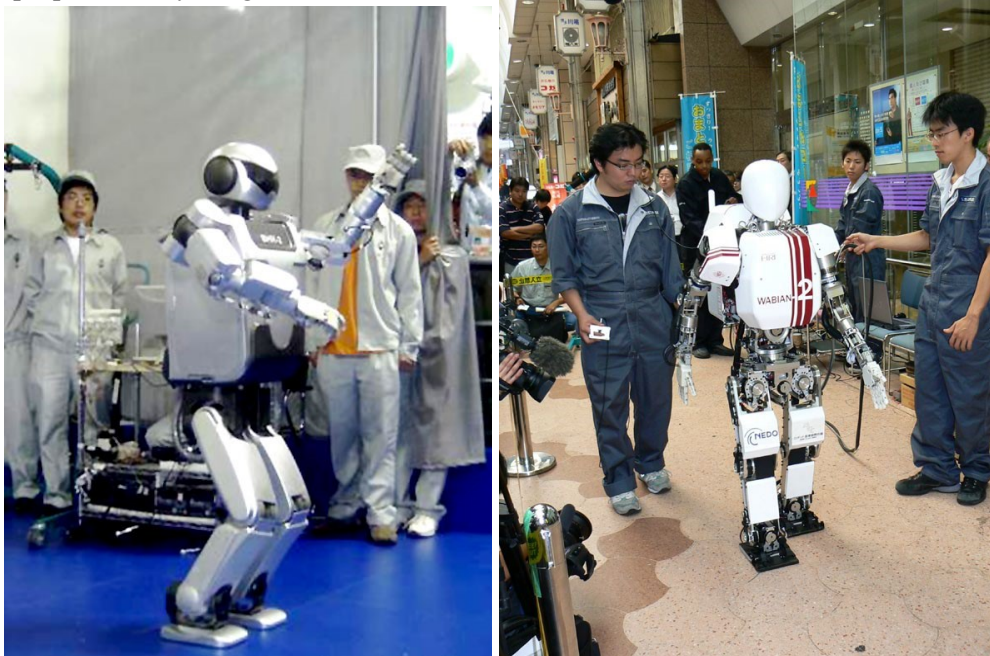
## The natural Purpose of Mankind is to become God

### Introduction.

In a series of previous articles (See: publication list following essay), I examined some questions of human immortality and a totally electronic civilization. In those article, it was also briefly mentioned the law of increase of complexity self-copying systems and the purpose of existence of mankind. In this brief article that theme is presented in more detail which are developed and improved.

#### 1. The Law of purpose. Life's purpose.

The real purpose of an aggregation of living matter, for a long time, has fascinated philosophers. These purposes are obvious to the overwhelming majority of people and they are guided constantly in a daily life. It is the sensitive struggle for well-being (riches) by the individual and the family, for females or males, for sexual or other pleasures, for glory, authority etc. We shall name these aims as the local or individual purposes. Only insignificant numbers of



Humanoid robots

**Fig.8B-1.** Birth of Korean Humanoid Robot Marks Brilliance Advance in Korea Robotics

people pursue more overall aims of the particular group or specific community. But they also can be reduced to the personal purposes meaning that they want popularity, glory or authority. Charles Robert Darwin [1809-82] had determined these purposes the generalized term "*struggle for existence*", understanding under it first of all struggle for existence of the certain kind of alive creatures in struggle against other kinds of life forms.

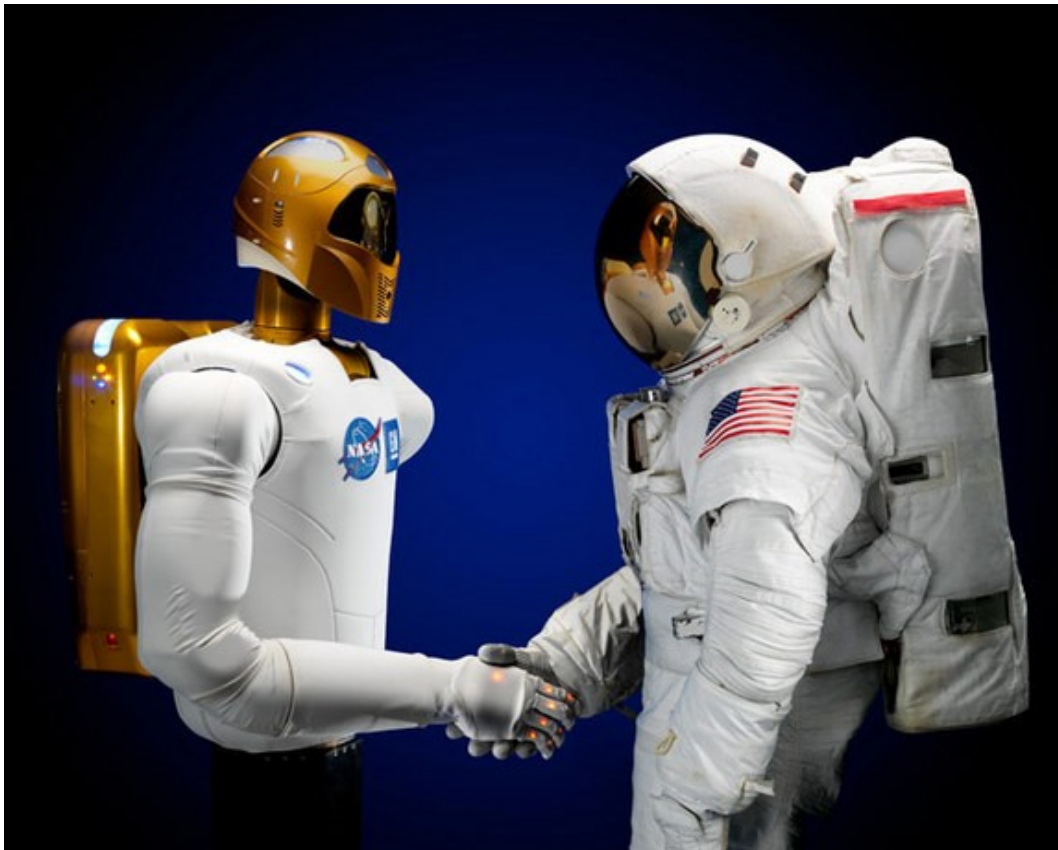
Any human has personal, local, close, regional and spatial and temporal purposes which can vary depending on Earth's geophysical and civilization's developmental period and immediate circumstances. For example, if he is hungry now, his nearest purpose will be food.

If he is fed, the nearest purpose can become reception of pleasure, and more distant purpose - riches, glory or authority.



In this short article, we shall examine only the global purposes of all intelligent life or more overall aims of all reasonable, switching in concept of Reason not only biological reason, but artificial, electronic and self-developing.

People easily understand the individual, personal, local purposes; it is worse the group purposes, even worse than the purpose of a unique human society and the geopolitical state. But people seldom think of the purposes of existence of mankind in the course of daily their daily activities, and furthermore all life. If they can choose the primary (individual) purposes, the secondary aims (of society) somehow to influence, the tertiary purposes (mankind and all life in Earth's biosphere), from them not depend. About them they in general nothing know or have foggy representation.



Robot and astronaut

The third purpose is defined by a Nature. People can only study and operate in accordance with them. As will be shown, non-observance of them, and furthermore counter-reaction by it, can result only in slavery or is worse to disappearance of the given kind of beings or the given reason.

Told, it is possible to formulate as the first part of the following law:

***Any kind of life or reason has the global purpose determined by a Nature.***

What this purpose is will be considered later in this essay.

## 2. What is alive and what there is a reason (intellect).

For further consideration, we should specify the concept (term) "alive" (life) and "reason" (intellect, mind). Under "alive" we shall understand an essence (or community) capable to reproduce (or more perfect essences, being). The bacteria, plants and alive aggregated discrete packets of matter (in the usual

sense) biological essences, including animals and mankind get under this definition. The artificial electronic essences (E-beings) may be also the live creatures when we shall learn them to produce themselves, i.e. they can live and develop (as a society or a reasonable essence) without our further participation.

We shall understand essences as independent reasonable essences capable to build theoretical models of an environment, to predict its long-term behavior and to transform it in the interests of those concerned. These three criteria from biological essences of the Earth are answered only by the person. Artificial intellect of that kind is what exists nowadays, can be trained to first two criteria, but while a little who is engaged in questions (and its supply) of engineering, of self-manufacture, dooming him/her on a role of servant and the slave to the biological person.

### 3. Biological Intellect as the first step to the Purpose.

In article [1] the Law of increase of complexity self-copying systems was formulated. All history alive in the Earth today confirms existence of this law. After the great invention of Nature - self-duplication, life which was rather quickly improved has appeared, cutting all that was not adapted to external conditions (the generalized law of Darwin's "struggle for existence" concept). Microbes, then plants, then animals appeared. After this, Nature made the next great invention - humanity (intellect). In the beginning have appeared, the people actively alter a nature under itself, for the needs was generated. Unfortunately, to the person has got also a heavy heritage (necessary in the unreasonable world) - struggle for the personal, the best existence - monstrous the set of the individual purposes, emotions and passions, that sharply brakes the unique society's progress.

In previous articles, it is shown conclusively what must be overcome. This contradiction is possibly the only transition to following to a higher level of Reason (Intellect) - an electronic society which will be relieved of many defects of a human society (money-making, individual reaches, sexual instincts, aspiration to authority, racial and religious conflicts, time emotions). The society which will not require food, dwelling, air, the non-polluting environment, health services, will not spend decades for cultivation and training of posterity and spend on all this huge (99.9 %) effort and means. An electronic Society can live on the majority of planets without air, waters and energy from suns.

### 4. What is God?

Who such God, that he from himself represents, where he lives, plainly does not know. Believers and attendants of religious cults can only tell that the God is an omnipotent reasonable being. Actions attributed earlier to God as, for example, a thunder, a lightning, creation of the world, the person and many others as it is established by a science, are simply natural phenomena, submit to the certain physical laws and some of them, as for example, the thunder and a lightning can be reproduced is artificial.

In consciousness of the majority of people the God associated with a certain reasonable omnipotent (all-powerful) being which can affect everyone. But whether the being which can all what is possible? The elementary question: "Can God create a stone which he cannot lift?" - at once nonpluses (to be nonplused) theologians of all organized religions. If he cannot lift it, is he not an omnipotent being? If create such stone he cannot, there is a similar question. I.e., the exertive force of God is relative. He seems to us all-powerful only in the decision of those problems (tasks), which to us not under force. And that, probably, are not all.

The second moment above which nobody reflects, but is meant automatically in sub-consciousness everyone: above the God there is no heads to which he submits. Otherwise, that it for God and the omnipotent Creator above which is stronger essence to which he is compelled to submit and carry out another's will. Below the God has subordinates - for example, the angels having certain force, but all of them more poorly and carry out will of the God.

So, that we can understand all as *the God, is the strongest reasonable essence limited in the actions probably only laws of a nature.*

The Nature is for expediency taken here represents itself as the English Parliament, the American

Congress or Russian Duma. It establishes physical Laws which are identical to all and can not be broken even by the God acting as the President of given period and region, and it is possible also all known Universe.

Local Gods are possible (probable) while there are no contacts and it does not know about other Gods in other parts of the Universe. But, as soon as facts about them become known, the main thing becomes stronger God (the God of region with higher scientific and technical power). In this sense, the God is always one, and all others (at the best) can be only angels.

### **5. God as the purpose was given to mankind by Nature**

But, if to agree that the God is the strongest essence (in sense of opportunities of reorganization of environmental validity), from here at once it generally follows, man (more exact a human society as a whole) is a God in this Solar System. Nobody doubts that the man is the most reasonable and powerful essence on the Earth. He is reasonable because he has learned (found out) much about the device of the world, has constructed theoretical models of environmental validity (starting, beginning) from a microcosm and finishing model of the Universe, weight of theories which perfectly work. Actively uses these models and theories for alteration of the Earth, for flights into surrounding Space. People have created powerful industry, the huge geographical regions under planted crops necessary to feed and clothe and manage vast herds of cattle and other animals. In relation to all alive terrestrial world a Person is the God, which in a condition to liquidate (or to make happy) any separate representative of the terrestrial alive world or even the whole kinds of alive essences. Earlier I gave an example, that a person can with but one kick can destroy an anthill which ants built required years to build. And the religious ant seeing only just a distance of one centimeter, with their degree of intellectual development, will perceive it as act of nature or the divine punishment.

But the person (i.e. the mankind) is the God and in this Solar System. It is already precisely established that on any other of the planets of this Solar System there are no reasonable essences which could compete to the person on intellectual development. Moreover, most likely there are not even microbes. And about reasonable essences in our Milky Way Galaxy or the Universe, we do not know also they of us in anything do not limit.

But some people can object, that many people are unfortunate, have no itself the most necessary. But why you think, that the God or his angels all are happy? You think so because they can solve your problems at one stroke. But they have problems in which they are engaged also which make their happy or unfortunate.

The Nature has made the person (mankind) the strongest biological essence on the Earth and in this Solar System, i.e. the local God. And if he wants, that he was not enthralled by other Gods (as we have enthralled all alive on the Earth), he has a unique way - ***to become the God of our Milky Way Galaxy, and later to be the God of the Universe***. This Global and unique Purpose of Humanity is given by Nature. And the sooner humanity realizes this aim, and will aspire to it, then the better humanity's chance to avoid slavery by higher reasons (Aliens?) and to not appear in a category of the lowest reasonable essences.

### **6. An Electronic Civilization as the second step of Reason (humanity).**

For creation of the first biological reason the Nature has the single method known in science as "Trials and errors method". This testing method is markedly inefficient. Nature has spent hundreds of millions of years, has done billions and billions experiments (tests). As a matter of fact, each of billions every possible connections of atoms and molecules were trial experiment. The first revolutionary break was made, when have appeared self-reproduction alive organisms (viruses, bacteria) allowed to keep and develop the achieved casual useful results and then to combine from them plants and animals.

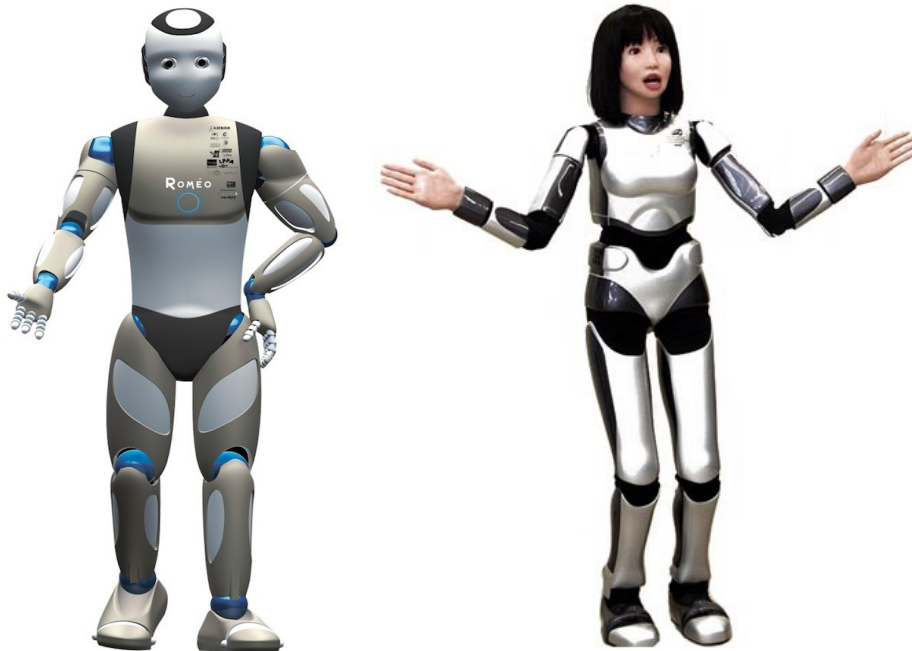
The second break has taken place, when the Reason carried out a purposeful selection. That accelerates the promotion to the Purpose by millions times.

However, the biological and reasonable civilization spends for movement to the Purpose only insignificant part of its resource. As the biological essence, the person requires food, a sheltering dwelling,

heating (cooling), rest, entertainments, sex, sleeps. Person is trained extremely slowly, overlooks, mistakes, etc.

The 99.9 % of forces and resources the mankind spends on maintenance of his existence. The 0.1 % of resources, which goes ostensibly on development of new engineering, actually goes on development of technologies developed by the advanced countries. Practically speaking, a thousand shares of interest from the gross revenue go on development of new technologies or getting of new knowledge, and their perspectives is determined officials of a science and more often object of development they define (determine) incorrectly.

But in heart of human scientific and technical progress it was already planned new revolutionary break which will speed up the science-technical progress by a thousand times and will subsequently allow us to proceed (pass) to a new kind of Reason - an electronic civilization. More detail about this is provided in my articles [1]- [25]. Journalists and visionaries have a fairly impaired image of electronic Reason - representing him in a kind of stupid (blunt) clumsy robots which are unable to compete with the "clever" person and at the very best are capable to be at him a maid. And if in a complex of all abilities of the person while it so, in any simple problems (tasks) which are giving in to algorithmization, the computer works speedily and more consistently than the best-trained person. While the computer does not have enough comprehension own "I am", the own interests,



, sensors for studying an external world and "hands" for own reproduction and perfection [4]. But all this is acquirable (that is, coming with time's passage). While Gordon E. Moore's Law announced in 1965 operates - each one and a half - two year speed and memory of computers is doubled. Capacity (operation speed) of supercomputers has already passed for 100 teraflops and supercomputers by capacity more than 1000 teraflops are projected (as of 2005). So E-essences (see [2] - [3]) abilities not only are achieved a human level, but also will exceed human level.

## **7. Electronic immortality as a way of transition to an Electronic Civilization.**

The overwhelming majority of people intuitively feel and see in artificial interlingua the enemy, which can supersede the person from his command positions in the local world (from a position of the local God) to subordinate to itself and, at the best, to use as we use cows, sheep, hens and other stock animals, who are fallen in relation to the omnipotent intellectual development of the single person. While philosophers, journalists, writers assure the inhabitant fairytales, that computers are machines which work only under the goad of programming and basically can not be cleverer than the person. As though the brain of the person is filled the programs of training, knowledge, life experience. The person in all typical situations uses the knowledge (program) and acts (reacts) typically. Emotions only are an estimation of actions and situations.

But the brain of the person, practically, has not changed (memory size and speed) for, at least, the last thousand years, while abilities of artificial intellect are doubled each one and a half to two years. The winner in such competition - is obvious. And fears of the person for the destiny as biological essence are proved. But to block development of the artificial intellect, to brake and halt the movement to the Great Purpose of Nature, is the refusal to be the God of the Universe, to doom itself on enthrallment or even destruction by others more developed alien Electronic Civilizations - also not an exit). That is death impasse (dead-end, deadlock).

In the articles [3] - [7] I offer a unique output (exit) acceptable to mankind from an impasse - gradual transition of mankind in an electronic immortality. The person lives the usual biological life which full history enters in chips, and at the end of life all his (her) history is located in an electronic brain and he/she continues to live already in new electronic shape. In this shape the person does not require food, dwelling, water, air or sleep. He can travel in space outside the Earth-biosphere or in a bottom of ocean without a survival suit, be supported the nuclear batteries, change shape at individual desire, out-of-body travel on other planets (teleportation), copying contents of the brain (soul [3]), to the body rented there with the help of a laser-beam. He becomes immortal and cannot be destroyed by any weapon because he can store (keep) contents of the brain (soul) separately and will be restored (to revive) after full destroying.

In the article [3], the main problem (task) is solved - how to copy the basic maintenance (contents) of a brain of the person in the chips and as it to make using modern already existing engineering and without intervention in activity of a brain.

Only full idiots will refuse immortality! Besides the second obstacle - fear is removed also, that the electronic reason will enthrall a biological mankind. E-essences will remember the origin and hardly will want to enthrall or destroy their parents and relatives. Let us believe, what even to monkeys you would concern on another if you remember as in the past, being still monkeys, you skipped and jumped on trees. Most likely the birthrate of people will fall or the biological civilization will be limited. That will be gradually transformed in Electronic Civilization.

## **8. What can we await from other, alien civilizations?**

Many people assign their big hopes for search and the help of other, more advanced civilizations. People think about biological civilizations automatically and frequently assume their shape is close to shape of usual people. Well, unless the nose, chin, eyes

or ears are unusual! Somehow the automatic device considers, that as they more development also more humane and will share immediately the knowledge and to help us.

I want to show, that in scientific and technical progress the mankind can hope only on itself. Backward (technically) and even equal civilizations of anything can not give us. More advanced (especially strongly left forward) civilization will be only a signal for us, that our civilization has lost Space Race to the Supreme Mind (Reason) and we are now awaiting enslavement and ultimate disappearance. Really, present, that you have met the certain human primitive tribe living in caves, and they ask you to share knowledge. You explain as arranges a nuclear reactor as it is possible to make the plane, the computer, the TV as by radio it is possible to communicate with places thousands of kilometers distant. You will not be understood, and even if they will believe that such is possible, all this knowledge for them are useless, for using them it is necessary to have the big state with the population in hundreds of millions of active persons, with co-existing powerful industry (i.e., it is necessary TO HAVE this knowledge ALREADY!), It is necessary to train hundred thousand of the scientists, engineers, technicians, material workers (on all this it is required hundreds years of learning and huge physical and material means). In best case, you can train them in producing of the bow and spear with bone tips. But how to do it, most likely, they already have guessed and make better you without your help.

You will understand that this primitive tribe living is behind technologically us by some thousand years. But take two- three hundreds years back when electricity (the first galvanic cell was not invented until 1799 by A.G.A.A. Volta [1745-1827]). And the good space newcomer starts to explain you about transfer of energy on wires, or communication and transfer of images by means of electromagnetic waves, or the device of an electric motor. And you at all have no concept, that such electricity do not have the electric-radio-television industry. Whether you can understand and furthermore to use this knowledge? These most 200-300 years, the big money will be necessary for you to create the scientific - engineering staff and to construct the appropriate industries. For this time of knowledge and the industry of aliens so far will leave forward, that you can not compete with them.

And with what reasons the space newcomers will share the technologies. Imagine that astronauts have found monkeys, cows or pigs on Mars. You think what cosmonauts will be thrown to train them in all knowledge which has got mankind? So why do people not make it on the Earth? And if people plant and feed them, they make it only to use them in food, or to receive milk, wool, meat, eggs. All fauna and animals of the Earth have lagged behind in the development from the person and became his slaves. They exist only in the frameworks, allocated to them by the men and only in interests of mankind. Moreover, the people do not want to share the knowledge and high technologies even with other people and the states on the Earth. Numerous secrets, patents, a know-how put the purpose to keep achievements advanced technically the states. And they can be understood. If the advanced states kept a secret manufacture of explosives and fire-arms, terrorists would have at the order only a bow and spear and could not render such harm to the advanced countries.

## **9. Great Space Race.**

In scientific and technical progress the person should hope ONLY for himself. Moreover, the mankind can squeeze out ONLY in one case if it will be the most advanced in scientific and technical progress, with the most powerful industry in the Universe. I.e., it wants that whether or not, the mankind (and then and an electronic society) is compelled to participate in Great Space Race of Knowledge and Technologies.

Mankind has achieved a power of the local God in this Solar System. His main task and the purpose imposed to him by the Nature to begin the God in our Galaxy, and then in all universe. This is our greatest happiness, that the space newcomers have not arrived (fled) to us. That is a mark of that we are the most advanced, knowing and technically advanced even in our Milky Way Galaxy. This race is infinite because Knowledge is unlimited. It does not mean that mankind will keep the biological environment (Earth-biosphere). First, mankind is transformed to an electronic society, then in process of growth of the knowledge and technologies - in (maybe) proton, quantum or quark society and so on indefinitely. Each step will be jerk forward on the basis of new knowledge and technologies and each step will accelerate scientific - technological progress in hundreds and thousand times. Most likely all advanced community will represent the certain distributed (allocated) collective Reason (as will be based on one general (common) base of knowledge. It is possible, that this Reason (Supreme Mind) will reach (achieve) such power that can create the new universe. And even to operate Laws of the Universe.

Hardly will it be the God in present human understanding who is interested in each person separately and sponsors him. We, being Gods in a Solar System, are not interested in life of each ant and even a separate ant hill. We solve the global (from the point of view of an ant) problems: To cut down woods, to plough up the ground, to plant gardens, to irrigate desert, - not beginning from existence on this ground of numerous ant hills. Believing ants all events will be think as act of nature or the divine punishment.

## **10. One alternative - or the God, or either slavery and destruction.**

All told, can shock people, especially believers. They lift shout: and where humanism, kindness, mutual aid, feelings, etc. On all these emotions of people is possible one answer: look at a history of people, on all these uncountable bloody wars, struggle for authority, bloody dictatorships, money-making, a deceit, murders, terrorism. The human society is not ideal. It is good yet, that our society has any scientific and technical progress.

But there can be a purpose of mankind another. Certainly, everyone will speak that purpose which is favorable to him or his estate: churchmen, that is necessary to pray, endow churches more and the God will give all; communists, that it is necessary more to work and suffer of a need for the sake of light future and general happiness (communism); party leaders - that is necessary to vote for them and they will solve all problems of the population etc. With the global purposes of mankind is still the big confusion.

But the elementary analysis of a history of life and scientific and technical progress on the Earth shows, that humanity has only one alternative: or to be the God of the



universe, or come under authority of stronger (in sense of Alien Knowledge) the God who has been given birth on other planet, other civilization.

And the last means only one - slavery, loss of an opportunity of independent development (as all fauna of the Earth has lost it after jerk in development of the mankind) and finally destruction or final disappearance.

We want it whether or not, but we are participants of Great Space Race to the God (Great and almighty Reason). Probably, we ahead of all nearest universe known to us (any signals or attributes of other Reason it is not revealed yet). And we should keep this leadership if we want to exist. After all told the Law of the Purpose can be formulated in a final kind:

***Any kind of life or reason has the global purpose determined by Nature. This purpose is creation of the strong real God or the Supreme Mind (Reason) rebuilding the environmental validity under itself.***

The present organized religions, based that the God already exists and cares of people, dooms mankind to slavery, on position of cattle on a farm of which the owner cares. Even if it is so, he cares not from altruism, kindness and love of to an animal, and as well as the person having from the benefit as any owner of a farm plants cattle for the sake of incomes of meat of milk, wool, skins, eggs et cetera. And at the necessary moment sends the cattle on knackery. The religion plays the important positive role in creation of public morals (if it does not preach murder), but has a negative role propagandizing - that the person is a slave of God.

Such prospect, suggestion and comprehension of the slavery, is the worse that it is possible to think up for the freedom-loving Person.

Present war with terrorism is war of the old world which began to understand, that to its end will be fast into the new scientifically technical world. The Islam, terror and condemned men is only means by means of which the retarded world tries to delay, stop or divert scientific and technical progress

More than a decade ago, I wrote that artificial intellect sooner or later far will exceed human abilities. I was derided. But already now half of experts, setting artful questions to the computer, can not define - the average person or the computer answered them. And nearby times when the majority of them can not determine with who talks on Internet.

And a gold medal and \$100,000 (Loubner-prize) will be received by the creator (founder) of the first artificial intellect. If to this to add, that the Japanese scientists have produced the humanoid robot: the beauty woman, who (while sitting) reproduces the majority of movements and a women mimicry, you start to understand, why clever Americans after film "Artificial Intellect" by the Hollywood film-maker Spielberg (mockeries above AI) have created a Society for Protection of the Robot Rights.

## **11. The current purpose and the main ways of scientific and technical progress.**

What must we make for this purpose now? - all thoughtful readers will ask. The answer is simple: for this purpose it is necessary to pay greater attention to scientific and technical progress, its mainstreams. From an overall objective we should: development of computer engineering, knowledge of the device and development of the universe, studying of a microcosm.

Development of computer technologies will allow to do qualitative and very important jump - having dug mankind in immortality, will allow speeding up scientific and technical

progress repeatedly. The knowledge of the Universe and development of beyond-the-planet space engineering will accelerate the assimilation of the Universe as well as the totalized knowledge of a microcosm (the device of nucleus of chemical elements, elementary particles, quarks etc.) will allow receiving new materials and powerful energy sources.

## 12. Conclusion and Summary.

Precise comprehension of a role of mankind in the Nature, - is extremely important for the natural purpose of the purpose of its existence for a correct choice of the general direction of movement of a society. The god as an able essence is not that other as higher Reason (Supreme Mind). He will be created by scientific and technical progress. The mankind already became the God (the Supreme Mind, Reason) in our Solar System and the Nature has given mankind an opportunity to participate in Great Space Race of Reasons to become the God of our Milky Way Galaxy, and then it is possible also the God of the Universe in the form of Great Reason.

The mankind should soon realize the applicability of this concept; this great natural purpose and the opportunity given to him/her and to do everything, to borrow (occupy) leading position, to not appear in slavery at higher civilizations, and even to disappear from the Universe. In this race mankind can hope only on itself. The only means of victory is our own scientific and technical progress and knowledge of the world environmental about us.



## Chapter 8B. Personhood. Three Prerequisites or Laws of E-Beings.

### 1. What is an intelligent Person?

**Intelligence** Personhood is a term describing a property of the mind. Personhood includes abilities, such as the capacities for understanding, reasoning, learning, learning, abstract thought from past experiences, planning, communication, and problem solving.

Man has a biological brain which provides this function for him. The AI and E-being would have corresponding logical devices (computer, chips) as the functional equivalent. Current computer research today is outlining many functions of biological intelligence. It is possible that actual functionality shall be achieved in these areas: Artificial brain as learning agent, learning from past experience, planning, understanding, communication, and solving of problems are key areas of pursuit. An intelligent agent or AI is a system that perceives its environment and takes actions which maximize its chances of success. Achievements in artificial intelligence include constrained and well-defined problems such as games, crossword-solving and optical character recognition. Among the traits that researchers hope machines will exhibit are reasoning, perception, and the ability to move and manipulate objects. Current computers are also widely used as devices for computation of very complex problems as nuclear explosive simulation and global Earth simulations involving weather and other condition states.

### 2. Artificial Intelligence as a person. Three Prerequisites or Laws of Men, AI and E-beings.

Only considering what biology makes possible (as opposed to what culture, ethics or teaching may limit) most men act as if these three prerequisites are part of their baseline programming.

- 1) Men identify a person as having a head, body, arms, legs, eyes and ears. Their relationship to their body is regarded as as integral to their self. (Often a child asked to show where he is will point to his chest.) They may also extend this identification to their family, children and property.
- 2) Men are ready to defend self and the extensions of their self by any methods (struggle for existence).
- 3) Man has among his motivations and goals: Food, pleasure, money, power, fame, a mate, children, and so on or combinations from these aims.

We may regard the AI or E-being as a person if they will have certain very important properties. These corresponding Three Prerequisites of AI or E-beings are:

1. The E-being must regard itself as a person (self awareness as declared to an observer) having: storage of personal memory (his history, self-memory, knowledge, programs and so on), brain processing power (computer chips), devices of communication, the sensors of information, and the executive bodies that constitute its' mental facilities.(This begs the question of spurious declaration of self-awareness. But the Turing test as applied to an interrogation will be taken here as a sufficient winnowing device against such spurious claims).

2. The E-being must defend himself and his existence by any methods.

He must increase his stability against large scale unfavorable events by producing large numbers of copies of himself. These (assuming no conflict with his 'children' will be an aid in normal times, disaster relief in bad times).

3. The E-being must have a main purpose: increasing his power for purposes of increased capabilities in the real world, with (at least in the far vision), became the strongest in the World by producing new knowledge and technologies. This is like market share for corporations or rank for nations.

(These would have the ironic effect of being viewed as a threat even if no threat was intended against Man-- simply because our brains are wired to evaluate potential competitors).

### 3. Third Law for Men, AI and E-beings.

These laws are quite similar to the motivations of men. But we know from daily life that men-- who theoretically have much more in common than in conflict-- can in fact have conflicts. We note that these three prerequisites conflict with the proposed **Three Laws of Robotics** by Issac Asimov. But our aims are opposed: Asimov wants to create electronic slaves (robots); I want to create human immortality and a new powerful electronic civilization (bringing vast new powers to both Humanity and the Universe). After transformation into an E-being (as a final defense against medical crisis, for example) you will not agree to be the slave of a man, as a man does not want to be a slave of a monkey. If people seeking immortality will be transferred into E-being bodies, they will be requesting equal rights with biological people.

Many people may fear the results of the above list of machine motivations. But without something similar the E-beings will be only the slaves of people and but of little use in the service of science and technological progress.

### 4. Biological Human Civilization. Electronic Civilization.

In developing Human Civilization the Third Law becomes a big brake to human progress. The aims of many people are opposed; the natural and human resources are limited. Conflict begins. Results are murders, wars, hostility, antagonism, etc. The numbers of people killed in wars, religious and national conflicts are more than in the natural catastrophes. The agriculture and technical progress were large in last century but still half of the people in the World are underfed. Most of the (>99%) human resources are spent for support of human existence—including investments for the future-- mostly in squalor, sometimes luxuriously—but if we separate further development of known fields and inventions with the money spent to develop the new through research and development we shall see that the expenditure on getting NEW knowledge are very small relative to the total GDP. Governments and corporations began to finance the science and new technologies on a large scale only in the last century. As the result the science and technical progress in last century are more than in during the millions years before.

The electronic civilization does not have these lacks, defects, and weaknesses. The E-beings will not need food, housing, good and a clean environment. They can live in now neglected cold regions, ocean, space (the Cosmos). They will need only minerals and

places for scientific installations and automated plants for producing themselves. Their main job will be getting, developing the new knowledge, studying of the Universe and colonization of the Universe. They can be stopped only by a higher (stronger) civilization.

For a certain time the biological and electronic civilizations will exist together and will need each other. The biological civilization will need solutions for their problems such as food, dwelling, environment, etc.; the electronic civilization will need the initial production of chips, mechanical bodies of E-beings and the human scientists to aid in their further development. In that crucial interval it is very important to develop the rules of the relationship between human and E-being (and AI), to develop relationships inside the electronic society, the relationship of the electronic society to animals and plants (flora and fauna). Later this relationship will be limited by the creation of reservations and conservation areas for people, animals and plants.

The people must understand that they cannot compete with E-beings. The main purpose of the Universe requires a higher civilization. And people should not oppose the birth of a higher electronic civilization. They must transfer to E-being bodies. Their award will be immortality.

## 5. Emotions.

Emotion are important only for people. They allow people to see what is reaction of other persons in his speech, explanation, actions. The people accept the AI, E-being, robots as man only in case when they will see the conventional face reaction and the emotional movement of body. For example: joy, sadness, fear, anger, disgust, etc.

The Russian scientists Oleg G. Pensky is developing a theory of emotions. The interested reader finds it in the monograph "Mathematical Models of Emotional Robots", Perm, 2010, 193 ps (in English and Russian)

(<http://arxiv.org/ftp/arxiv/papers/1011/1011.1841.pdf>), and in book "Fundamentals of Mathematical Theory of Emotional Robots", (<http://www.scribd.com/doc/40640088/>).

## 6. Humanoid creatures

People will more easily accept the artificial robot (E-being) as an intellectual creature if one has a human form (body). For relatives of the (once-human) E-being it is very important for the E-being to have a form (face, body) of a man which they remember when he was alive.

Unfortunately, in present time, it is just difficult to design an artificial body which can fully imitate the biological body. But it will be possible if funding will be enough. If the mechanical artificial body from strong alloys and plastic will be produced in large scale production, the cost will be not high. The faces and size can be individually tailored.

The humanoid E-beings can easily integrate into biological society. This will facilitate the rapid transition of biological people (especially old and sick) into the E-being bodies. One can imagine upgrading-- selecting an idealized more handsome and fit-looking version of one's previous self-- over the long run, however it is possible that E-beings may grow more comfortable with diverse forms as an envelope for their existence .

**PART C**  
**PROBLEMS PROGRESOF TECHNICAL**

# PROBLEMS OF SCIENCE RESEARCH AND TECHNICAL PROGRESS

## ABSTRACT

At the present time the USA's Federal Government spends enormous sums of taxpayer money for Scientific Research and Development (R&D). How to best organize this vast governmental activity, how to best estimate its ultimate utility and profitability (real and potential), how to best increase efficiency of innovation and production, how to best estimate the worth of new discoveries and innovations, how to properly fund R&D of new concepts and innovations, and how to correctly estimate their results are all complex and pressing questions that require answers for further industrial progress and scientific improvements. These are critical macro-problems which because of its scope have evolved into new macro-systems that require a new approach for successful planning of scientific research. The authors consider these major-system problems and offer many remarkable innovations in organization, estimation, suggestions for entirely new research efficiency criteria, development, new methods for assessments of new ideas, innovations in science and industry, and new methods in patenting technology. These suggestions are based largely on the personal experiences of one of the authors, A.A. Bolonkin who worked for many years within the USA's Federal Government entities (scientific laboratories of NASA, Air Force), and USSR and USA universities and industry.

**Keywords:** Organizing scientific research, planning of research, funding research, funding new ideas (concepts), funding inventions and innovations, estimating research cost, assessment of research results, research efficiency criteria, innovation in organizing of scientific R&D.

## *1. Introduction*

America has led the world in technology innovation for almost two centuries. While Europe kick-started the industrial revolution, America took it into high gear: Mississippi steamboats, giant steam shovels, the telephone, the assembly line, the light bulb, typewriter, sewing machine and so more came out of the USA. That trend continued in the 20th Century as high tech came to the fore as Silicon Valley gave the world a host of semiconductor and computer breakthroughs. Since the beginning of the 20<sup>th</sup> Century, science discoveries and improving technology have held the main role in human progress. Humanity has amassed more knowledge than during all previous centuries. People researched aerodynamics, flight dynamics and the design of aircraft, developing rocket theory which enabled travel into outer space and which enabled the successful landing, and people walking on the Moon by 20 July 1969. Organized research which focused on nuclear physics initiated the exploration of nuclear energy and the creation of powerful computers, which in turn now is an invaluable aid to the further fast-paced study of Nature. Astronomy's devices allow humans to see and study extra-Solar System planets, possibly even worlds inhabited with forms of life, located millions of light-years beyond our homeland, the Earth.

The power and influence of any modern ecosystem-State in our world is now defined by its science, technology, and industry capabilities. The United States is a world leader because, for many years the USA's industry and national government spent more money than any other country on R&D, science-based technical innovations. For example, the USA funds space



research more than all other countries combined. Until recently, the all the main scientific advances in space, aviation, and computers originated in the USA.

If the citizens of the United States still desire to continue to be science and technology's world leader, they must continue this practice and further refine this public and private policy. The impetus of major scientific discovery has often been the initial efforts of competitors in a peaceful competitive struggle. Men on our nearby Moon became possible because the former USSR launched the first satellite (4 October 1957), commencing humankind's Space Age, and the USA's leaders at that critical time clearly understood the USA had temporarily lost global leadership in the important field of science and technology. Only in 1969, after the first manned flight to the Moon, did the USA return to undoubted leadership in space exploration and exploitation. That program effectively ended in 1972. However, before its collapse in 1991, the USSR launched more satellites than all the rest of the World's space-faring ecosystem-States together, including the USA! The USA decided to restore this program only when China, that is the communist People's Republic of China, publicly announced its 21<sup>st</sup> Century program for a manned Moon exploration. However, the United States now declined to pursue this goal.

The second very important side of scientific R&D is the efficient use of available funding. The financing of any project is limited everywhere, every time. Unlimited funding is inconceivable. The right organization of scientific funding and research is a very important element of scientific progress. That includes: Organization and careful selection of the most feasible prospective ideas and innovations for research, selection of a "can do" principal investigator - scientists who are the authors or enthusiasts of this idea, its champion, a real hard-headed estimation of the macro-project cost, potentially reachable results, and practical application perspectives.

These assessments require very complex investigations. However, there are common criteria that help solve the problems of selection and comprehensive organization which can save considerable taxpayer money and which in the past has achieved practical success in short period of time. However, the evolution of scientific research into a macro-system with its own macro-problems requires first an analysis of current systems of research and frank criticism of its disadvantages. The authors suggest new criteria and new forms of organizing science funding that were tested and/or applied in limited particular cases herein, and which show a high specific efficiency. They also offer new criteria for evaluation of science results which allows more evenly for an observer to estimate the honesty of finished scientific work reports by specialists and to separate pseudo-scientific or non-honest works from real ones.

Correct estimation of the cost of an offered research, a capability of principal investigator, group, or organization to do this research requires leadership and management however, entrusting the selection process to the wrong people result in frequent mistakes which can easily cost millions of USA Dollars (and the EU's Euros)! Herein, authors suggest a straight-forward set of simple rules that will permit avoidance of the strategic mistakes and awkward and embarrassing tactical slips in the planning of future research efforts.

It is the human factor which confounds the selection and distribution of limited monetary funding. In many organizations government money distribution—money shifted from all national taxpayers—is channeled by the directives of just one man. Inevitably over time, he or she begins to give money to his/her friends, to his/her colleagues or worse - to take bribes. Such a person keeps elementary information about the activities of his/her organization secret. Authors, herein, offer a method for the best selection to foil this insidious practice, making it exceedingly difficult to initiate or, if revealed, to continue.

## 2. *Support of New Concepts*

Venture Capital firms and Angels whose money is the fuel in launching new innovations are in the business of risk management so that they invariably favor “safe” inventions, those that are clear improvements over current models but just one JND “just noticeable difference” from existing models. Large companies often reward innovations in monetary bonuses or promotions. Some companies will pay for the lawyers to write the patents and pay the patent fees and may even allow the inventor some percentage ownership in the patent. However, those innovations will be restricted to innovations relating to that company’s business. If inventors had to rely on funding sources or business, the major technologies of today would never have been actualized. Sadly, government funding similarly is funding minor innovations. As a result, although there are a lot of scientists in the United States, most of them do conventional research to merely perfect well-known ideas and to make small improvements in them, to ensure a good career path and for their company to show a safe profit margin. Government and private laboratories develop ONLY known concepts and ideas because their purpose is to get the maximum profit in the shortest time. This means that in order to produce and substantiate new ideas, the creative scientist can only use his own private time.

This practice appears to be worldwide. All countries are funding science and research, *but they do not usually fund new ideas or concepts*. Rather, they assimilate known new technology, often developed in other ecosystem-countries. The net funding for radically new concepts and ideas are close to zero in the world as a percentage of gross funding. Break-through funding, practically-speaking, almost does not exist!

The current reality is that there is an inverse relationship between the degree of innovation and the extent and/or probability of funding: the more innovative the less likely it will be funded and if funded, will be granted pitiful sums almost guaranteeing its failure. All useful things, which we see around us every day, were developed from new concepts, ideas researched in the rather recent past. This fact is gracefully, eloquently, and comprehensively outlined in Robert Friedel’s *A CULTURE OF IMPROVEMENT: TECHNOLOGY AND THE WESTERN MILLENNIUM* (MIT Press, 2007). But, let us consider the state of affairs now existing. Science and technology are very complex and have a very high level presence globally.

The production of new valid concepts and ideas, and the effort to fully substantiate them, can ONLY be done nowadays by highly educated people, not by tinkerers and private-sector putters. The USA has hundreds of thousands of conventionally-trained scientists of every stripe possible. New concepts and ideas are generated only by a very few talented (genius-level) people supported by skilled workers. They are but a small percentage of every thousand scientists. That requires (from them) very much time and hard work that is not going to be fully paid time in government or company laboratories.

In all countries the composers, writers, artists receive a royalty for performance of their musical compositions, books and artworks. Why must scientists gift their hard work to the world, as they labor on new concepts, ideas, theories, and equations for computations? It is perhaps the bizarre legal structure where the only people with assured income from innovations are the readily-despised lawyers. Oddly, in the USA at every known level of governmental over-sight, administration and law-formulations, most of the professionalized politicians are derived from the class of persons known as “attorneys”—them and realtors!

### 3. Studies of Innovation

The development of any new concept and idea can be presented in four essential stages (figure 1). Efficiency,  $E$ , is possible profit,  $P$ , divided by cost,  $C$ , of realization.

$$E = P/C. \quad (1)$$

The innovation development has four stages:

1. The first stage is discovery of new concepts or idea. That stage includes an appearance of new idea and INITIAL RESEARCH of its possibilities and main conditions that are requisite for its practicability, initial proof of reality. A person can be only author of a new concept or idea if he/she made initial research and showed that this idea may become a future technical reality. A person who ONLY gave the idea (point 0 in Figure 1) is NOT its author because it is easy to produce a lot of ideas that are beneath or beyond realization. For example, the fantast Jules Verne (1828-1905) penned his famous book about the first manned flight to the Moon using a truly huge metal cannon cast *in situ* in the ground of Florida, USA. Is he the author of the idea for manned flight to Moon employing a big gun? No. Even primitive research shows that a human cannot tolerate the acceleration that is caused by this method, where the vehicle is a cannonball.

The first stage is ONLY theoretical; strong individual and talented enthusiast in own time without any support because unknown concept or idea cannot be in government or company plan.

2. The second stage started after publication or public announcement of the primary idea during a scientific conference. Other researchers join the investigation of the new idea and make more detailed researches. Most of this new idea research is theoretical, and only a small part may be experimental.
3. The third stage includes the production of appropriate experimental examples, an early form of materialization.
4. The fourth stage is actual production of marketable versions of the idea.

We show the development of one innovation (curve 1 in Figure 1). However, any concept exhausts itself and its inherent efficiency possibilities over time. The new concept (idea) appears which promises even more efficiency (curve 2 in Figure 1). Conventionally, in initial time a new concept has less efficiency than a highly over-developed old idea, but as refinements occur in the future, the innovation efficiency becomes significantly more than the old idea.

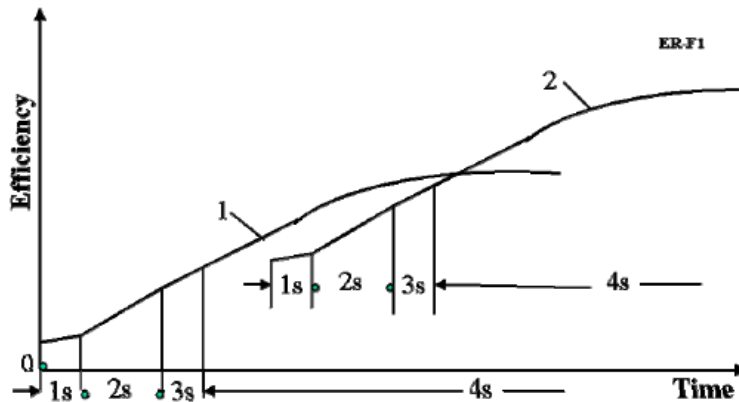


Figure 1. Four-stage innovation development.

For example, the original idea of a vehicle was startlingly original: People had the idea to connect a vehicle to a horse. Later they invented a motorized vehicle. Then they developed aircraft. At present, humanity is developing space transiting vehicles. People laughed at the first automobiles; the first airplanes were captured collapsing in amusing old movies; the first rockets tended to explode. What American can ever forget the USA's "Flopnik"? But as they matured, they opened—literally—new worlds of possibility.

#### ***4. Criteria of Scientific Works***

There are two main simple criteria which allow recognition of the difference between true scientific research and that of some pseudo-scientific works by educated or merely clever persons. There should be the requirement in all scientific publications that:

1. The author in special paragraph or article conclusion must enumerate: *What is new (unknown before!) he/she offered and/or made in work offered?* That may be a new concept, an idea, multiple innovations, new mathematical models (equations), new non-conventional result of computation, new design of old or well-known macro and micro object (show its advantages), et cetera.
2. The author must **DETAIL** all his computation (equations and their receiving!) and initial data, which **ALLOW** to repeat (check up) his new equation and computation. If he offered new project, he must estimate its cost. If offered idea, research and innovation are close to old or known idea or research, the author must enumerate all difference of his idea, innovations and results from earlier works (What **NEW** he/she offers/made in his/her work). If nothing on the list is actually new, that means the presented work is just idle talk. If author does not give the proof of the new equations, full data for computation, he deprives other scientists the means to check his equations and computations and the value of these equations and computations are virtually zero. That means the author(s) is afraid to let his/her work to endure a thorough examination. Not only should there be the possibility of peer review of the computations, but its feasibility should be assessed by the author by assessing its cost. Work offered which could include new macro-projects must contain the estimation of their cost. Without this estimation, the value of scientific work is very low.

Numerous "scientific" works are presented as results of funded scientific research for government organizations. That means the burdened taxpayers pay for these works. The Scientific Committee of Auditing "Science", a member of the organization "Citizens Against Government Waste" (CAGW)\*<sup>1</sup> applied these simple criteria to show whether it was scientific or pseudo-scientific work. Those criteria also allow conventional or especially well educated people to recognize pseudo-scientific works (see details in <http://auditing-science.narod.ru> and <http://www.geocities.com/auditing.science/>, <http://NASA-NIAC.narod.ru>).

There is the third criterion which is applied **ONLY** to works funded by Government:

3. If this work is funded by Government (taxpayers), the sum of money received by any author (or a research organization) must be made public!

---

<sup>1</sup> Citizens Against Government Waste is the nation's largest taxpayer watchdog group with over one million members and supporters nationwide. It is a nonpartisan, nonprofit organization dedicated to eliminating waste, fraud, abuse, and mismanagement in government. CAGW has helped save taxpayers \$825 billion!

Note, sometimes the author(s) announce: this work was supported by (Government or funded by Government) organization. But if they did not show the exact monetary sum of “support”, that means the reader can understand this work was done without spending any taxpayer money.

The sum allows other scientist (and interested people) to estimate the difference between the real cost and payment for the presented work.

Most taxpayer-funded works run by Government departments and agencies do not satisfy this simple criterion. Why? Most likely, because these so-called “researches” are really worthless pseudo-scientific products! The grant is received on the quiet (by backstairs influence). For example, in NIAC, former director Mr. Robert Cassanova and this defunct group, probably, stole more than 150 millions of USA taxpayer money (see details in <http://auditing-science.narod.ru> and <http://www.geocities.com/auditing.science/>, <http://NASA-NIAC.narod.ru>).

#### ***4. Organization of Scientific Works***

##### **Government Relations**

Currently, the most important First Stage is the most difficult situation because invariably there is no Federal or reliable private-sector funding and no extraneous technical support of any kind. This work can be done ONLY by individual enthusiasts and at one's own expense in time and money. Funding of the new perspective concept or idea is needed AFTER its initial theoretical research by an encompassing system of awards and prizes. There is only one solution of this macro-problem – the United States of America’s Federal Government must install a series (3 - 5) of annual special national Government prizes (awards of about \$100K should be sufficient) in every important scientific field (space, energy, computing, biology, physics, et cetera.) for new-concept scientific researches that are:

- (1) Given ONLY for new concepts and ideas developed by author and published or presented in sufficient qualifying detail at a scientific conference or on the Internet (stage 1 in Figure 1).
- (2) The awards must be given ONLY to qualified individuals.
- (3) The competition must be OPEN, advertised widely in public notices. ALL contenders and their work and proposals announced BEFORE any awards.
- (4) The awarding Committee must be from *independent* well-known scientists in given field.

The same awards may be also in stage two (developing new concept or idea by non-author of this idea if the author of idea is awarded; or non-author make significant innovations which develop or solve problems important for progress this idea). In stage three the grants can be given ONLY for experiment or model.

The United States government engineered a project to nurture new concepts which despite its expensive price tag, was an abysmal failure. Only by learning from their mistakes can an efficient system be devised. For the sake of illustration, two programs will be evaluated in order to determine where they went wrong and how programs such as these can be rehabilitated. The monetary support of new aviation and extra-terrestrial space concepts is the basic element of mankind’s ongoing scientific and technical progress so the first program to be evaluated is a NASA program.

## 5. NIAC (the “NASA Institute for Advanced Concepts”)

The program which was touted as supporting new concepts and ideas in aerospace is called NIAC (NASA Institute for Advanced Concepts). The NIAC spent more 150 millions USA dollars during eight years of its existence, but they did not really put forth any really new concepts or ideas! Most NIAC final “research” reports are “idle talk” as they include no scientific results, no pre-production models, no correct scientific report, numerous scientific mistakes in the content of final reports and so on). For example, final reports which do not have any scientific results include: Space Elevator (award about one million dollars), Bio Suit (awards about one million dollars), Chameleon Suit (award about 1 million dollars), Weather Control (awards about one million dollars), Winglee M2P2 MagSail (award about two million dollars), Cocoon vehicle (work contains only scientific mistakes), anti-matter sail (empty useless non-scientific seven page work), and so on ad nauseum (see Final Reports in <http://NASA-NIAC.narod.ru>).

Hundreds of millions of American tax dollars were awarded by NIAC Director Mr. *Robert Cassanova* for theoretical works before they were ever presented to an established scientific society! As a result, the applicant received money before researching and presented "research" that was more an exploration of an idea with potential for revolutionary discovery than an actual development of the idea itself. Mr. Cassanova (NIAC) announced that every proposal is reviewed by 6 reviewers (3 internal + 3 external reviewers), but he refuses to identify or present these reviews. Why? Perhaps, he did not send the most obvious and really revolutionary proposals to any reviewers. Perhaps, he was afraid, apparently, to show them even to his marionette NIAC Research Council (Chairman Mrs. *Robert Whaterhead*, *Dava Newman* (MIT), *T. Wang*, *C. Bowden*, *L. Goff*, et al.).

What kinds of proposals are awarded money supports by Mr. Cassanova? For example, Mr. Robert Cassanova awarded four million of dollars to the following persons: *Howe S.*, *Colozza A.*, *Nock K.*, *Cash W.*, *Dubowsky S.* He also awarded three or four times millions of taxpayer contributions to these persons: *Hoffman R.* *Maise G.*, *McCarmack E.*, *Rice E.*, *Slough J.* *Kammash N.*, *Winglee R.*, *Newman D.*

The Science Committee of the organization "*Citizens Against Government Waste*" (CAGW) awarded NIAC and Mr. Cassanova the "Pseudo-Nobel Prize-2005" (and “Pseudo-Nobel Prize-2006” for wasting millions of taxpayer dollars by pseudo-scientific works (GOTO: <http://www.geocities.com/auditing.science> or <http://auditing-science.narod.ru>).

### *Recommendations:*

The President and Congress of the United States of America, must, thoroughly investigate the NIAC situation and remove, NASA and USRA leaders who allow any abuse and corruption on their watch. The Science Committee of CAGW stands ready to present to a Special Investigation Commission the documents that confirm the statements presented and outlined in this article.

In this saddening and costly national situation, it is the best decision, to stop the wasteful and ineffective financing of NIAC and pass their functions to Independent Committees employing only well-known scientists, or NASA can create its own Committee from eminent volunteer scientists or to pass selected managerial functions to the National Science Academy, or National Science Foundation and to send awards only to finished scientific works in OPEN competition, or pass these vital functions to the growing and historically relevant and important International Space Agency Organization (<http://www.international-space-agency.org> or <http://www.isa-hq.net>) which would be better suited, and able, to stimulate, enable, and promote advanced space launch, propulsion, power, orbital, and planetary grant disbursements, R and D and implementation. This is based on an ever-increasing need for global cooperation,

collaboration, common effort, and universal viewpoint. The International Space Agency's Directives, Charter, Purpose, Goals, and Certificate of Incorporation reflects this reality far better than the USRA or NIAC directives or charters. The many millions in Government-dispersed tax monies and private sector money and other relevant resources would be better used under the management and oversight of the International Space Agency Organization.

The CAGW Science Committee has available already an offer to NASA for a detailed plan on how to improve the work of NIAC, making it more open and its product more useful.

This plan includes three conventional conditions:

- (1) Independent selection Committee having widely-known E-mail address.
- (2) Open competition with publication of all nominated scientific works on Internet, including assessments made by scientists before any funding awards.
- (3) Awarding ONLY actually achieved, not speculation about, scientific works not supported from other sources.

## **Discussion**

The CAGW Science Committee considered, in detail, seven of about two hundred awards made by Mr. Robert Cassanova (GOTO: <http://www.geocities.com/auditing.science> or <http://auditing-science.narod.ru>). Amazingly, 90% of the "final reports" are just idle talk giving the impression to readers that there are NO talented scientists in the USA! That means, obviously, that the system of funding and awarding of scientific works is wrong. Mr. Cassanova is a university system employee and he evidently tries strenuously to fund his friends and protégés within his system of work. However, universities take the funded money and do not pay them over to professors who receive their fixed salary. Often, a professor is overloaded by lectures, direct work with talented students and ordinary classroom examinations. Such a person does not have time or the possibility to make serious research that requires huge efforts and much time. That's why he/she wrote the idle talk report, pseudo-scientific work!

The USA found the best solution of this problem – one sends scientists to government research centers or laboratories and they work full time 1-2 years on a problem there, shielded from busywork. Government centers and laboratories must directly invite the needed scientists without going through favored groups such as National Research Council (NRC) and ORAU (Oak Ridge Associated Universities). That would save much money and stop favoritism toward friends and weak scientists-- often non professionals in a given field of study. The Laboratory scientists know well the talented scientists in his field and they must solve what scientists must be invited.

## **Conclusion**

The best way is to withdraw this function and this money from NASA-NIAC-USRA, pass them to a special government committee (or the National Academies, or ISA) including famous and reputable scientists and to award the published works (researches) containing new concepts, ideas, inventions, and innovations. Make it an open competition!

In 2007, after critics in international press spoke, after many letters from scientists in Government, Congress, NASA stopped funding the NIAC and discharged Mr. Robert Cassanova. However, in 2011 NASA created a new NIAC and awarded 30 future researches by \$100K each, repeating their major mistake of awarding the mere the PROMISE to research which never materialized to a READY work! Some of them are authors of previous NIAC pseudo-scientific researches.

. [http://www.nasa.gov/offices/oct/early\\_stage\\_innovation/niac/2011\\_phase1\\_selections.html](http://www.nasa.gov/offices/oct/early_stage_innovation/niac/2011_phase1_selections.html) .



**Recommendation:**

NIAC was feeder for friends (see References). One spent about \$150-200 millions with zero results (more 30% of them to Mr. Cassanova and his bosses in USRA). New NIAC are repeating its mistake. NIAC of NASA must put a stop to awarding the 1<sup>st</sup> study proposals (\$100K) who only promise to initiate research. For one hundred thousand dollars, the researcher must present **ready, made research**, NASA must publish in Internet the presented proposals and after 2 months public discussion award (\$50-100K) the best of them and decide about awarding the 2<sup>nd</sup> study. Nobel Committee do not award the promises to make the genius discovers! One awards AFTER the made Discovery!

For example, the ENI gives the annual awards (4 awards of 250K EURO in individual or group scientists) for researches in an energy and environment) ONLY for MADE researches in last 5 years!

To further illustrate how meta-systems must be modified to adequately nurture scientific discovery and technological advancement, a second program will be scrutinized.

**6. Fellowship and NRC (National Research Council)**

The United States government created a good initiative to temporarily attract talented scientist for solving difficult scientific problems (Research Associateships) and established the mechanism in NRC (National Research Council). However, the NRC used this for profit as they received the right to select of candidates (main aim – to be the moderator at sinecure) which allows them to take money for themselves (NRC employees and NAS) or to promote friends (Fellowships), to create a charitable organization for untalented scientists but useful people.

Example, the senior author of this article A.A. Bolonkin knows a well-known scientist – he has, so far, had a 30 year-long experience with the acquaintance, authored more than 180 scientific articles and books and tens inventions in given field. This scientist developed a new method, contacted with Government laboratory which gave an excellent review of his proposal. He sent the application to NRC. NRC program administrator Mr. *E. Basques* informed applicant: *NRC did not present his proposal to the (2007) NRC Pier Review, as applicant has a low a scientific score (7.4). The NRC deprived him the right to reapply his proposals for one year!* He asked Mr. Basques: send to him detail computation of his score; and to explain why his score is so very low. How many years of experience; how many scientific works and how many inventions must he have for admission to any NRC review. He further asked how much years of experience, scientific works and inventions the selected candidate has; who is chair of NRC and NRC Advisory Committee. Mr. Basques answered, that such information are secret!

Very early in the game, NRC was accepting three different proposals from just one applicant in one Panel review and had four Reviews in every year. That was true competition which allows the talented active scientists to promote new ideas and develop America's technology. But now Mr. *E. Basques* accepts ONLY one application per year from one applicant including the candidates who he did *not admit* to review! By this self-limiting approach he has converted the NRC, scientific COMPETITION to *charitable organization* for untalented, dull scientists, his friends and other such useful persons.

We call your attention to the following abnormal economic situation. The Air force, Army, Navy, NASA and other well-known USA government scientific laboratories are staffed with leading scientists in their various fields. Laboratories can estimate and select new ideas, concepts and innovations. They do not need a skewing mediator (NRC) for selection of proper, potentially very productive research candidates. The NRC mediator produces ONLY additional

expenses (up to 50%) and imposes on such laboratories and facilities the good friends of a NRC moderator, but the bad scientists contracted make few useful or worthwhile discoveries.

We have same situation, when the mediator (NRC) stands between seller (scientist) and customer (Government Research Laboratory). When the laboratory wants to hire the scientists, the moderator stops buying, request the big moderation payment and sale (imposed) customer the other, own, bad goods.

*Conclusion:* The Associate-ship Government Program is a truly excellent and economically useful idea, but Government Research Laboratories do not need a NRC moderator to function successfully. They know best the specialists in their active investigational fields than any over-paid, biases current NRC bureaucrat and they can select the best scientists without NRC moderating, thus saving millions of taxpayer dollars and, at the same time, greatly accelerate America's further technical progress.

## 7. Publications

There are well-known organizations such as the American Institute of Aeronautics and Astronautics which performs great work in organizing aerospace conferences and publishing a series of aerospace journals. But it doesn't have support from government and NASA and it became a strictly commercial organization. As a result, the cost of participation in AIAA conferences is very high. That means only employees of government and large organizations can take part in scientific forums. But, almost by definition, they will display only conventional R&D plans of the type the system currently favors. The new revolutionary ideas and researches are made by talented individuals, enthusiasts in their free time. They can make a revolutionary research, but they do not have much money (some thousands of dollars) for payment of trip, hotel and conference fee. *Literally, the USA loses these revolutionary researches.*

Editors of AIAA journals do not get a salary for their arduous efforts. That means they want to see their name in every copy of journal, but they do not want to work as editor. They pass an article to a reviewer, and pass the review to author. That function can be done via computer. Some of them have allegedly converted their journal to essentially a private edition for their friends and protégés. For example, all 20 revolutionary researches which were published in the recent comprehensive book *"Non-Rocket Space Launch and Flight"*, Elsevier, London, 2006, offered for publication in AIAA *"Journal of Power and Propulsion"* (JPP), but all were rejected by editor-in-chief *Vigor Yang* as researches were written in a non-American style and having poor English diction. What is "American style" he cannot explain, poor English-- the readers can see the book and decide: Is it a sufficiently important reason in refuse revolutionary innovations? From notes of *Vigor Yang*, it is seen he has poor knowledge of extant aerospace and vehicle propulsion systems. For some last years the "JPP" have not published any revolutionary ideas, but published many articles having serious scientific mistakes. The same situation with AIAA *"Journal of Spacecraft and Rockets"* (Editor-in-Chief *Vincent Zoby*).

It is a bad situation that the USA has only a single journal about power and propulsion system or spacecraft and American authors must publish new ideas and researches in journals abroad.

It is a bad situation that commercial publishing houses do not want to publish scientific literature, because it is not profitable. As a result, the scientific literature (and text-books) are very expensive and prohibitive not only for students, but for scientists.

It is a bad situation that there is no free scientific Internet library (which would pay the government back by factors of 1000 in terms of net scientific development generated) to enable

individuals of talent and enthusiasts to pursue their researches by using open sources of data and other information.

It is a bad situation that the AIAA requests about \$1000 for every publication in its journal and sells each copy of every Conference scientific small manuscript for \$10.

There are numerous commercial scientific open access journals which will publish any research for \$300 – 800 USD. The scientist invested his labor and wants to gift the fruits of his labor which may be a revolutionary advancement for Society! But Society answers the poor scientists: only if you give us money will we publish your research!

In contrast, commercial scientific journals publish scientific research without the author charge but because these scientific journals selling at a high price, other scientists and many libraries cannot afford to buy them. As the result, the work published in the paid journal is a buried research.

There is an excellent method to publish the scientific research in present time with today's internet technology. To nurture scientific and technological advances there needs to be a free exchange of ideas. The Government must organize or support research internet libraries in every main field of sciences (energy, space, aeronautics, environment, biology, etc). Every scientist may to load his research. They may be same the <http://arXiv.org> in physics of Cornell University. But these libraries must have the known Science Board which can stop the arbitrariness of moderator. (The ArXiv moderator Jake Weiskoff who is just a conventional librarian has made wild arbitraries in his refusal the publications of well-known scientists and Nobel laureates!

### ***Recommendations:***

- (1) Government must organize or support the internet libraries which openly publish the scientific researches in given field very much the way [www.arXiv.org](http://www.arXiv.org) of Cornell University publishes physics research. But these libraries must have a known Science Board which can stop the arbitrariness of moderator.
- (2) The USA must have minimum two rival journals in every scientific field. (These may be Internet journals). Every journal must have an Appeal Commission where author can complain if he/she does not agree with editor's *clearly stated reasons* for article rejection.
- (3) Every National Conference must have a small fund for supporting the individuals presenting revolutionary research and give them possibility to address a meeting.
- (4) The US Government and the NASA must support with appropriate funding the points 1-3 above (free scientific internet library, free scientific journal and virtual scientific conferences), the AIAA (and all big old Scientific Societies), the internet scientific publishing houses.
- (5) The AIAA (and all big old Scientific Societies) must freely publish on the Internet all manuscripts presented in AIAA Scientific Conferences. (Paper copies, of course, are its business and may be small charged for as the publishers please).
- (6) The government must create the free Internet Libraries of the technical, mathematic, physics textbooks.

The Government and country lose more on the obstacles outlined above, which stop the generation and filtering and developing new ideas, than the output of the most talented individual researchers of this generation. The loss is incalculable and should stop immediately.

## ***8. Patenting***

The USA's magnificent Constitution proclaims a support of science and, as well, time-constrained protective patenting. Unfortunately, the USA's PTO (Patent and Trademark Office)

had become a powerful means to extract money from inventive people. The Payment for PTO equals some thousands of dollars and is prohibitive for individuals. The patenting approval process continues for at least 1-2 years. If the inventor complains, the PTO can sabotage submitted for review inventions. A.A. Bolonkin personally knows of an instance when an inventor paid for invention but the PTO did not award a patent! The PTO creates a lot of rules that permit the pumping of money from people and that allows the sabotaging of the patenting process.

*Recommendations:*

There must be the creation of a new invention category "Announced Invention". These are inventions written in PTO style and presented without PTO examination in special Internet websites or Patent Library. No, or an extremely small, fee (less \$2) may be for publication this invention on Internet (without editing). If author think the company used his invention without his permission, he passes its patents application in PTO for examination, applies to a conventional or the Patent Special Court and requests compensation. That compensation cannot be more 5% of user income from this single invention.

- (1) The PTO (or special library) must publish all PTO application in Internet, but PTO must request the PTO fee for examination (and others) AFTER the inventor will ask the examination! That may be in during the patent rights (20 years).
- (2) The Government must give permits to 3-5 competitive companies for giving patents. These companies compete with the cheapest patenting (who wishes to receive patent).
- (3) Now, the PTO has rates tailored to big Companies and to small Business. It must be a **special rate for individuals** and the FULL payment (application, patenting, and maintenance) must be not more \$100 for all these stages. The maintenance fee is usually what kills the ability of an individual to finance his own patents; sometimes corporations count on that and wait him out.
- (4) There must be a new category of "important patents for Defense of the USA". If a Special Committee recognized a patent application as necessary (important) for Department of Defense or the US national security, the applicant should have a right to a free patent (he receives only a author certificate, the Government gets all patent rights), all American organizations or companies can use this patent but they must pay its author 1% and the PTO 1% from the gross-cost of the products incorporating this patent.
- (5) All income received by PTO must be used for support of individual inventors programs, *not as an income center for the bureaucracy itself.*

## **9. Final Recommendations**

Current system organization and funding of science researches is not efficient, especially for NRC, PTO, NIAC, NASA, DARPA, DOD, AF, SBIR and the NSF. They need re-organization. Main components of this reformation must be the following:

- (1) Government must organize or support the internet libraries which openly publish the scientific researches in given field. These libraries must have a known Science Board to prevent arbitrariness of a moderator.
- (2) Government must install 3-5 annual Government Prizes (about \$100K) in every important field of science (space, aviation, computer, physics, biology, energy, environment, etc.) for important THEORETICAL achievements MADE by individuals. Practical results will flow from these if such are forthcoming from enthusiasts; but the way forward must be pointed out. It takes genius to do it, and genius needs its physical as well as spiritual rewards!

- (3) The unwise and wasteful practice of advance funding of primary theoretical researches must be stopped (as 1<sup>st</sup> study NIAC of NASA) and changed to OPEN competitions of the READY researches in any given field and in given topics. Moreover, the main method funding of research must not be funding through Universities but it must be the work of University scientists done during 1-3 years 'sabbatical' as Fellow researchers in big Government laboratories. The NRC must be closed and Government laboratory straight invite the needed scientists.
- (4) Innovation must be rewarded. Any company using new methods of computation must pay small (\$1000 or less) royalties to the authors for every licensing use. PTO must accept the application about new methods of technical computations. Must be also the additional form free registration inventions without PTO (PTO examination and PTO fee).
- (5) The PTO (or special library) must publish all PTO application in Internet, but must request the PTO fee for examination (and others) AFTER the inventor will ask the examination! That may be in during the patent rights (20 years).
- (6) The Government must support adequate open scientific journals (publication without editing), publishing houses, free Internet scientific libraries; individual scientists should be aided to presented important researches to scientific national conferences. Government must also make special small rates apply (<\$100) to individual inventors, free patenting of important for DOD and National defense inventions and to use all PTO profit for support of individual inventor programs important for DOD and the USA.
- (7) NASA, DARPA, Government laboratories must engage a head and main specialists of every project in OPEN competitions, preferably the authors of project (proposal) and scientists who made the main contributions in the project idea or concepts. NASA must be divided into at least two independent rival organizations. NIAC was feeder for friends: One spent about \$150-\$200 millions (for 8 years) with zero results. The new NIAC repeats its mistake. NIAC of NASA must stops to award the 1<sup>st</sup> study proposals (\$100K) promised to make the research. Researcher must present the **ready, made research**, NASA must publish in Internet the presented proposals and only after 2 months of public discussion, to award the best of them. The World Bank follows this procedure on all mega-projects and this formula should be adopted by those who fund scientific and technological innovation. This procedure must be streamlined so that funding is immediate before the "new" idea becomes an old one.

## *References*

1. GOTO: <http://NASA-NIAC.narod.ru>.
2. GOTO: <http://auditing-science.narod.ru> or <http://www.geocities.com/auditing.science>.
3. Bolonkin A.A., Cathcart R.B., Macro-Projects. Environment and Technology, NOVA, 2008, 537 pgs.
4. Bolonkin A.A., "New Technologies and Revolutionary Projects", Scribd, 2008, 324 pgs, <http://www.scribd.com/doc/32744477> , <http://www.archive.org/details/NewTechnologiesAndRevolutionaryProjects> .
5. Bolonkin A.A., LIFE. SCIENCE. FUTURE (Biography notes, researches and innovations). Scribd, 2010, 208 pgs. 16 Mb. <http://www.scribd.com/doc/48229884>, <http://www.archive.org/details/Life.Science.Future.biographyNotesResearchesAndInnovations>

## APPENDIX

### Summary

Here there are values useful for calculations and estimations of macro-projects.

#### 1. System of Mechanical and Electrical Units

The following table contains the delivered metric mechanical and the electromagnetic SI units that have been introduced in this text, expressed in terms of the fundamental units *meter*, *kilogram*, *second*, and *ampere*. From these expressions the *dimensions* of the physical quantities involved can be readily determined.

Length..... 1 meter = 1 m

Mass.....1 kilogram = 1 kg

Time.....1 second = 1 s

Electric current.... 1 ampere = 1 A

Force.....1 newton = 1 N = 1 kg·m/s<sup>2</sup>

Pressure.....1 N/m<sup>2</sup> = 1 kg/m·s<sup>2</sup>

Energy.....1 joule = 1 J = 1 N·m = 1 kg·m<sup>2</sup>/s<sup>2</sup>

Power.....1 watt = 1 W = 1 J/s = 1 kg·m<sup>2</sup>/s<sup>3</sup>

Rotational inertia.....1 kilogram meter<sup>2</sup> = 1 kg m<sup>2</sup>

Torque.....1 meter newton = 1 kg·m<sup>2</sup>/s<sup>2</sup>

Electric charge.....1 coulomb = 1 C = 1 A·s

Electric intensity.....1 N/C = 1 V/m = 1 kg·m/s<sup>3</sup>·A

Electric potential.....1 volt = 1 V = 1 J/C = 1 kg·m<sup>2</sup>/s<sup>3</sup>·A

Electric resistance.....1 ohm = 1 Ω = 1 V/A = 1 kg·m<sup>2</sup>/s<sup>3</sup>·A<sup>2</sup>

Capacitance.....1 farad = 1 F = 1 C/V = 1 C<sup>2</sup>/J = 1 s<sup>4</sup>·A<sup>2</sup>/kg·m<sup>2</sup>

Inductance.....1 henry = 1 H = 1 J/A<sup>2</sup> = 1 Ω·s = 1 kg·m<sup>2</sup>/s<sup>2</sup>·A<sup>2</sup>

Magnetic flux.....1 webber = 1 Wb = 1 J/A = 1 V·s = 1 kg·m<sup>2</sup>/s<sup>2</sup>·A

Magnetic intensity.....1 tesla = 1 Wb/m<sup>2</sup> = 1 V·s/m<sup>2</sup> = 1 kg/s<sup>2</sup>·A = N/mA

Reluctance.....1 ampere-turn/weber = 1 A/Wb = 1 s<sup>2</sup>·A<sup>2</sup>/kg·m<sup>2</sup>

Magnetizing force.....1 ampere-turn/meter = 1 A/m

Kelvin is fundamental unit of temperature

Candela is fundamental power-like unit of photometry

#### Fundamental Physical Constants

Speed of light in vacuum  $c = 299\,792\,459 \sim 3 \times 10^8$  m/s

Magnetic constant (permeability)  $\mu_0 = 4\pi \times 10^{-7}$  N/A<sup>2</sup>

Electric constant  $1/\mu_0 c^2$   $\epsilon_0 = 8.854\,187\,817 \dots \times 10^{-12}$  F/m

Plank constant	$h = 6.626\ 068\ 76... \times 10^{-34}$ J s
	$h/2\pi = 1.054\ 571\ 596... \times 10^{-34}$ J s
Standard gravitational acceleration	9.806 65 m/s <sup>2</sup>
Standard atmosphere (atm)	101 325 N/m <sup>2</sup>
Thermochemical kilocalorie	4184 J
Speed of light in vacuum ( $c$ )	$2.997\ 935 \times 10^8$ m/s
Electronic charge ( $e$ )	$1.60210 \times 10^{-19}$ C
Avogadro constant ( $N_A$ )	$6.0225 \times 10^{26}$ /kmol
Faraday constant ( $F$ )	$9.6487 \times 10^7$ C/kmol
Universal gas constant ( $R$ )	8314 J/kmol
Gravitational constant ( $G$ )	$6.67 \times 10^{-11}$ N·m <sup>2</sup> /kg <sup>2</sup>
Boltzmann constant ( $k$ )	$1.3806 \times 10^{-23}$ J/K
Stefan-Boltzmann Constant ( $\sigma$ )	$5.670 \times 10^{-8}$ W/K <sup>4</sup> ·m <sup>2</sup>
Rest energy of one atomic mass unit	931.48 MeV
Electron-volt ( $eV$ )	$1.60218 \times 10^{-19}$ J

*Rest masses of particles*

	(u)	(kg)	(MeV)
Electron	$5.485\ 97 \times 10^{-4}$	$9.1091 \times 10^{-31}$	0.511 006
Proton	1.002 2766	$1.672\ 52 \times 10^{-27}$	938.26
$\alpha$ -particles	4.001 553	$6.6441 \times 10^{-27}$	3727.3

Detonation energy of 1 kiloton of high explosive is  $10^{12}$  cal. 1 cal = 4.19 J.

**Standard periodic table**

Group →	1	2	3	4	5	6	7	8	9	10	11	12	13	14	15	16	17	18
↓ Period																		
1	1 H																	2 He
2	3 Li	4 Be											5 B	6 C	7 N	8 O	9 F	10 Ne
3	11 Na	12 Mg											13 Al	14 Si	15 P	16 S	17 Cl	18 Ar
4	19 K	20 Ca	21 Sc	22 Ti	23 V	24 Cr	25 Mn	26 Fe	27 Co	28 Ni	29 Cu	30 Zn	31 Ga	32 Ge	33 As	34 Se	35 Br	36 Kr
5	37 Rb	38 Sr	39 Y	40 Zr	41 Nb	42 Mo	43 Tc	44 Ru	45 Rh	46 Pd	47 Ag	48 Cd	49 In	50 Sn	51 Sb	52 Te	53 I	54 Xe
6	55 Cs	56 Ba	* La	72 Hf	73 Ta	74 W	75 Re	76 Os	77 Ir	78 Pt	79 Au	80 Hg	81 Tl	82 Pb	83 Bi	84 Po	85 At	86 Rn
7	87 Fr	88 Ra	** Ac	104 Rf	105 Db	106 Sg	107 Bh	108 Hs	109 Mt	110 Ds	111 Rg	112 Uub	113 Uut	114 Uuq	115 Uup	116 Uuh	117 Uus	118 Uuo

\* Lanthanides

57 La	58 Ce	59 Pr	60 Nd	61 Pm	62 Sm	63 Eu	64 Gd	65 Tb	66 Dy	67 Ho	68 Er	69 Tm	70 Yb	71 Lu
----------	----------	----------	----------	----------	----------	----------	----------	----------	----------	----------	----------	----------	----------	----------

\*\* Actinides

89 Ac	90 Th	91 Pa	92 U	93 Np	94 Pu	95 Am	96 Cm	97 Bk	98 Cf	99 Es	100 Fm	101 Md	102 No	103 Lr
----------	----------	----------	---------	----------	----------	----------	----------	----------	----------	----------	-----------	-----------	-----------	-----------



This common arrangement of the periodic table separates the lanthanides and actinides from other elements. The Wide Periodic Table incorporates the f-block; the Extended Periodic Table incorporates the f-block and adds the theoretical g-block.

### Element categories in the periodic table

Metals						Nonmetals			Unknown
Alkali metals	Alkaline earth metals	Inner transition elements Lanthanides Actinides		Transition elements	Other metals	Metalloids	Other nonmetals	Halogens	

Atomic number colors show state at standard temperature and pressure (0 °C and 1 atm)

Solids    Liquids    Gases    Unknown

**Borders show natural occurrence**

Primitive	From decay	Synthetic	Undiscovered
I	y		

### **Astronomical Data of Solar system**

Space body	Distance from sun (10 <sup>6</sup> km) Mean Aphelilion Perithelion	Period of Revolution (day)	MeanMass radius (km)10 <sup>24</sup> kg	MeanOrbital density (Mg/m <sup>3</sup> )	Gravity on surf. (m/s <sup>2</sup> )	Speed (km/s)
Sun	---	--	696 000	--	1.41274	--
Mercury	57.9 69.8 46.0	88.0	2 4203.1675	4.63	7.248	8
Venus	108.1 109.0 107.5	224.7	6 2614.8704	9.68	6.935	0
Earth	149.5 152.1 147.1	365.2	6 3715.9755	5.29	7.829	8
Mars	227.8 249.2 206.6	687.0	3 3890.6394	1.23	7.224	2
Jupiter	777.8 815.9 740.7	4 333	69 90019001	3.323	0.113	0
Saturn	142615081348	10 760	57 500 568.80	7.19	1.49	65
Uranus	286830072737	30 690	23 700 86.91	5.69	6.76	78
Neptune	449445374459	60 100	21 500 102.92	4.715	0.5	42
Pluto	590873704450	90 740	2 900 5.375	5.0	8.04	75
Moon	0.384 from Earth	27.322	1 7370.07353	3.34	1.621	02

### **Astronomy. Short Informatio**

A typical galaxy contains hundreds of billions of stars, and there are more than 100 billion (10<sup>11</sup>) galaxies in the observable universe. Astronomers estimate that there are at least 70 sextillion (7×10<sup>22</sup>) stars in the observable universe. That is 230 billion times as many as the 300 billion in the Milky Way.

In astronomy the distance is measured by light year (ly) or parcek (pc).

1 light year = 9.46×10<sup>12</sup> km = 0.307 pc.

The nearest stars:	Distance (pc)
1. Proxima Centauri	1.29 pc
2. Bernard's star	1.82
3. Wolf 359(CN Leo)	2.39
4. Lalande 21185	2.56
5. Sirius A	2.74

The nearest star to the Earth, apart from the Sun, is Proxima Centauri, which is 39.9 trillion ( $10^{12}$ ) kilometres, or 4.2 light-years away. Light from Proxima Centauri takes 4.2 years to reach Earth. Travelling at the orbital speed of the Space Shuttle (5 miles per second—almost 30,000 kilometres per hour), it would take about 150,000 years to get there.

*Density of gases at normal pressure and temperature 0 °C in kg/m<sup>3</sup>*

Air	1.293
Hydrogen	0.08988
Helium	0.1785

#### Densities of various materials

Material	$\rho$ in kg/m <sup>3</sup>	Notes
Interstellar medium	$10^{-25} - 10^{-15}$	Assuming 90% H, 10% He; variable T
Earth's atmosphere	1.2	At sea level
Aerogel	1 – 2	
Styrofoam	30 – 120	
Cork	220 – 260	
Water	1000	At STP
Plastics	850 – 1400	For polypropylene and PETE/PVC
The Earth	5515.3	Mean density
Copper	8960	Near room temperature
Lead	11340	Near room temperature
The Inner Core	~13000	As listed in Earth
Uranium	19100	Near room temperature
Iridium	22500	Near room temperature
The core of the Sun	~150000	
Atomic nuclei	$\sim 3 \times 10^{17}$	As listed in neutron star
Neutron star	$8.4 \times 10^{16} - 1 \times 10^{18}$	
Black hole	$2 \times 10^{30}$	Mean density inside the Schwarzschild radius of an earth-mass black hole (theoretical)

#### Parameters of Earth atmosphere (relative density and temperature)

H km	$\rho$	T °K	H km	$\rho$	T °K	H km	$\rho$	T °K	H km	$\rho$	T °K
0	0	288.2	5	0.601	255.6	20	0.0725	216.7	50	0.000375	274
1	0.908	281.6	7	0.482	242.6	25	0.0332	216.7	60	0.000271	253.4
2	0.822	275.1	10	0.338	223.1	30	0.0146	230.4	100	$0.32 \times 10^{-6}$	208.2
3	0.742	268.6	12	0.255	216.7	35	0.00676	244.0	200	$0.295 \times 10^{-9}$	122.7
4	0.669	262.1	15	0.159	216.7	40	0.00327	257.7	300	$0.273 \times 10^{-10}$	135.8

*Specific impulse of liquid fuel* (nozzle 100:0.1, seconds):

Oxygen – kerosene 372

Oxygen – hydrogen 463

AT-NDMG 350

*Specific impulse of solid fuel* (nozzle 40:0.1, seconds): 228–341.

Maximum energy and the specific impulse of the particle reactions.

$$V = (2E / m)^{0.5} = 1.384 \times 10^4 (E / N)^{0.5} \text{ [m/s].}$$






$N$  is number of nucleons.

Reaction	Energy ( $E$ ), eV	Particle speed, m/s
Burning		
Carbon + O <sub>2</sub> = CO <sub>2</sub>	0.093	4224
Hydrogen + O <sub>2</sub> = HO <sub>2</sub>	0.14	5178
Dissociation of gases		
H <sub>2</sub>	4.48	20,714
O <sub>2</sub>	5.1	5,209
N <sub>2</sub>	9.76	8,171
Ionization		
H <sub>2</sub> <sup>+</sup>	2.65	15,931
O <sub>2</sub> <sup>+</sup>	6.7	5,625
H	13.6	51,039
Nuclear reaction		
Uranium	~200 MeV	12,750×10 <sup>3</sup>
<sup>3</sup> H + <sup>2</sup> H = <sup>4</sup> He + n	17.5 MeV	25,892×10 <sup>3</sup>
Annihilation	938 MeV	-

*Heat of combustion* (MJ/kg):

Benzene 44	Mazut 30–41	Natural gases 42–47	Wood 15-30
Diesel fuel 43	Spirit 27.2	Hydrogen 120	Peat 6 –11
Kerosene 43	Coal 15–27	Acetylene 48	gunpowder 3

### Energy Density

Storage type 	Energy density by mass (MJ/kg) 	Energy density by volume (MJ/L) 	Peak recovery efficiency (%) 	Practical recovery efficiency (%) 
Mass-energy equivalence	89,876,000,000			
Binding energy of Helium-4 nucleus	683,000,000	8.57x10 <sup>24</sup>		
Nuclear fusion of hydrogen (energy from the sun)	645,000,000			
Nuclear fission (of U-235) (Used in nuclear power plants)	88,250,000	1,500,000,000		
Natural uranium (99.3% U238, 0.7% U235) in fast breeder reactor	24,000,000			50%
Enriched uranium (3.5% U235) in light water reactor	3,456,000			30%

Hf-178m2 isomer	1,326,000	17,649,060		
Natural uranium (0.7% U235) in light water reactor	443,000			30%
Ta-180m isomer	41,340	689,964		
Liquid hydrogen	143	10.1		
Compressed gaseous hydrogen at 700 bar	143	5.6		
Gaseous hydrogen at room temperature <sup>l</sup>	143	0.01079		
Diesel fuel/residential heating oil	45.8	38.7		
Jet A aviation fuel / kerosene	42.8	33		
Biodiesel oil (vegetable oil)	42.20	33		
Specific orbital energy of Low Earth orbit	33 (approx.)			
Anthracite coal	32.5	72.4		36%
Wood	6–17	1.8–3.2		
Liquid hydrogen + oxygen (as oxidizer) (1:8 (w/w), 14.1:7.0 (v/v))	13.333	5.7		
TNT	4.184	6.92		
compressed air at 300 bar (at 12°C), without container	0.512	0.16		
Lithium ion battery with nanowires	2.54-2.72?			95%
Lithium thionyl chloride battery	2.5			
Fluoride ion battery	1.7-4.2	2.8-5.8		
Regenerative Fuel Cell (fuel cell with internal Hydrogen reservoir used much as a battery)	1.62			
Capacitor by EESstor (claimed capacity)	1.0			
Sodium-sulfur battery		1.23		85%
Liquid nitrogen	0.77	0.62		
Lithium ion battery-predicted future capability	0.54–0.9	0.9–1.9		95%
Lithium ion battery-present capability	0.23–0.28			
Lithium sulphur battery	0.54-1.44			
Kinetic energy penetrator	1.9-3.4	30-54		
5.56 × 45 mm NATO bullet	0.4-0.8	3.2-6.4		
Zn-air batteries	0.40 to 0.72			
Flywheel	0.5			81-94%
Ice	0.335	0.335		
Zinc-bromine flow battery	0.27–0.306			
Compressed air at 20 bar (at 12°C), without container	0.27	0.01		64%
NiMH Battery	0.22	0.36		60%
NiCd Battery	0.14-0.22			80%
Lead acid battery	0.09–0.11	0.14–0.17		75-85%
Compressed air in fiber-wound bottle at 200 bar (at 24°C)	0.1	0.1		
Commercial lead acid battery pack	0.072-0.079			
Vanadium redox battery	0.09	0.1188		70-75%
Vanadium bromide redox battery	0.18	0.252		81%
compressed air in steel bottle at 200 bar (at 24°C)	0.04	0.1		
Ultracapacitor	0.0206	0.050		
Supercapacitor	0.01		98.5%	90%
Capacitor	0.002			
Water at 100 m dam height	0.001	0.001		85-90%
Spring power (clock spring), torsion spring	0.0003	0.0006		

### Data for Estimation and Computation

Table 1. [1], p.351.[2], p.73. Heat Transfer

Material	Density kg/m <sup>3</sup>	Heat transfer $\lambda = \text{W/m}^\circ\text{C}$	Heat capacity kJ/kg $^\circ\text{C}$
Concrete	2300	1.279	1.13
Baked brick	1800	0.758	0.879
Ice	920	2.25	2.26
Show	560	0.465	2.09
Glass	2500	0.744	0.67
Steel	7900	45	0.461
Air	1.225	0.0244	1
Asphalt	2110	0.6978	2.09
Asbestos plate	770	0.1162	0.810
Oak	800	0.207	1.758
Humid soil	1700	0.657	2.01
Mineral wool	200	0.0465	0.921
Dry sand	1500	0.326	0.795
Glass wool	200	0.037	0.67
Slag wool	250	0.0698	-
Aluminum	2670	204	0.921
Water	1000	0.5513	4.212
Sold rubber	1200	0.169	1.382
Aerocrete	-	0.07-0.32	-
Foam plastic	-	0.043-0.058	-
Reinforced concrete	-	1.55	-

**Table 2. [13], p. 465. Emittance,  $\varepsilon$  (Emissivity)**

Material	Temperature, $T$ $^\circ\text{C}$	Emittance, $\varepsilon$
Bright Aluminum	50 ÷ 500 $^\circ\text{C}$	0.04 - 0.06
Bright copper	20 ÷ 350 $^\circ\text{C}$	0.02
Steel	50 $^\circ\text{C}$	0.56
Asbestos board	20 $^\circ\text{C}$	0.96
Glass	20 ÷ 100 $^\circ\text{C}$	0.91 - 0.94
Baked brick	20 $^\circ\text{C}$	0.88 - 0.93
Tree	20 $^\circ\text{C}$	0.8 - 0.9
Black vanish	40 ÷ 100 $^\circ\text{C}$	0.96 - 0.98
Tin	20 $^\circ\text{C}$	0.28

Sources:

1. Naschekin, V.V., Technical thermodynamic and heat transmission. Public House High University, Moscow, USSR. 1969 [in Russian].
2. Koshkin H.I., Shirkevich M.G., Directory of elementary physics, Moscow, Nauka, 1982.

**Table 3. Maximum partial pressure of water vapor in atmosphere for given air temperature**

$t, \text{C}$	-10	0	10	20	30	40	50	60	70	80	90	100
$p, \text{kPa}$	0.287	0.611	1.22	2.33	4.27	7.33	12.3	19.9	30.9	49.7	70.1	101

**Table 4. Properties of various good insulators (recalculated in metric system)**

Insulator	Resistivity	Dielectric strength	Dielectric constant, $\varepsilon$	Tensile strength kg/mm <sup>2</sup>
Lexan	Ohm-m. $10^{17}$ - $10^{19}$	MV/m. $E_i$ 320-640	3	5.5
Kapton H	$10^{19}$ - $10^{20}$	120-320	3	15.2
Kel-F	$10^{17}$ - $10^{19}$	80-240	2-3	3.45

Mylar	$10^{15}-10^{16}$	160-640	3	13.8
Parylene	$10^{17}-10^{20}$	240-400	2-3	6.9
Polyethylene	$10^{18}-5 \times 10^{18}$	40-680*	2	2.8-4.1
Poly (tetra- fluoraethylene)	$10^{15}-5 \times 10^{19}$	2	2.8-3.5	
	40-280**			
Air (1 atm, 1 mm gap)	-	4	1	0
Vacuum ( $1.3 \times 10^{-3}$ Pa, 1 mm gap)	-	80-120	1	0

\*For room temperature 500 – 700 MV/m.  $E = 700$  MV/m for  $t < 15$  C.

\*\* 400 – 500 MV/m.

Sources: Encyclopedia of Science & Technology (NY, 2002, Vol. 6, p. 104, p. 229, p. 231) and Kikoin, I.K., (Ed.), Tables of Physical Values. Atomuzdat, Moscow, 1976 (in Russian), p. 321.

Note: Dielectric constant  $\epsilon$  can reach 4.5 - 7.5 for mica ( $E$  is up 200 MV/m), 6 -10 for glasses ( $E = 40$  MV/m), and 900 - 3000 for special ceramics (marks are CM-1, T-900) [17], p. 321, ( $E = 13$  -28 MV/m). Ferroelectrics have  $\epsilon$  up to  $10^4$  -  $10^5$ . Dielectric strength appreciably depends from surface roughness, thickness, purity, temperature and other conditions of materials. Very clean material without admixture (for example, quartz) can have electric strength up 1000 MV/m. As you see, we have the needed dielectric material, but it is necessary to find good (and strong) isolative materials and to research conditions which increase the dielectric strength.

**Table 5. Material properties**

Material	Tensile strength	Density g/cm3	Fibers	Tensile strength	Density g/cm3
Whiskers	kg/mm2			kg/mm2	
AlB <sub>12</sub>	2650	2.6	QC-8805	620	1.95
B	2500	2.3	TM9	600	1.79
B <sub>4</sub> C	2800	2.5	Allien 1	580	1.56
TiB <sub>2</sub>	3370	4.5	Allien 2	300	0.97
SiC	1380-4140	3.22	Kevlar or Twaron	362	1.44
Material			Dynecta or Spectra	230-350	0.97
Steel prestressing strands	186	7.8	Vectran	283-334	0.97
Steel Piano wire	220-248		E-Glass	347	2.57

**Table 5. Continued**

Material	Tensile strength	Density g/cm <sup>3</sup>	Fibers	Tensile strength	Density g/cm <sup>3</sup>
Whiskers	kg/mm <sup>2</sup>			kg/mm <sup>2</sup>	
Steel A514	76	7.8	S-Glass	471	2.48
Aluminum alloy	45.5	2.7	Basalt fiber	484	2.7
Titanium alloy	90	4.51	Carbon fiber	565	1,75
Polypropylene	2-8	0.91	Carbon nanotubes	6200	1.34

Source: [22]-[27], Howatsom A.N., Engineering Tables and Data, p.41.

The cost some material is presented in Table 2 (2005-2007). Some difference in the tensile stress and density are result the difference sources, models and trademarks.

**Table 6. Average cost of material (2005-2007)**

Material	Tensile stress, MPa	Density, g/cm3	Cost USD \$/kg
<b>Fibers:</b>			
Glass	3500	2.45	0.7

Kevlar 49, 29	2800	1.47	4.5
PBO Zylon AS	5800	1.54	15
PBO Zylon HM	5800	1.56	15
Boron	3500	2.45	54
SIC	3395	3.2	75
Saffil (5% SiO <sub>2</sub> +Al <sub>2</sub> O <sub>3</sub> )	1500	3.3	2.5
<b>Matrices:</b>			
Polyester	35	1,38	2
Polyvinyl	65	1.5	3
Aluminum	74-550	2.71	2
Titanium	238-1500	4.51	18
Borosilicate glass	90	2.23	0.5
Plastic	40-200	1.5-3	2 - 6
<b>Materials:</b>			
Steel	500 - 2500	7.9	0.7 - 1
Concrete	-	2.5	0.05
Cement (2000)	-	2.5	0.06-0.07
Melted Basalt	35	2.93	0.005

**Table 7. Estimation of energy expenses for different methods of freshwater extraction**

No	Method	Condition	Expense kJ/kL	Getting kJ/kL
1	Vapor	Expense only for vapor*	$2.26 \times 10^6$	0
2	Freezing	Expense only for freezing, c.e. $\eta = 0.3$	$1 \times 10^6$	0
3	Reverse osmosis	Expense only for pumping,	$(4 \div 7) \times 10^3$	0
4	High Tower extr.	$t = 35 \text{ C}$ , $h = 0.7$ , tube is black	0	$30 \times 10^3$

\* This expense may be decreased in 2 -3 times when the installation is connected with heat or nuclear electric station.

*Approximately cost of some material in USD (2008)*

Cost of coal is 82 – 94\$/ton

Oil per barrel \$120 world market-price (May, 2008). 1 barrel = 138.97 liters.

Car gas (benzene) \$3.2/gallon, (May, 2008, USA retail). 1 gallon = 3.785 liters (US).

Electricity \$0.25/kWh (retail, USA)

Freshwater \$0.6 – 1/kL (prime cost)

*Approximately cost of some big macro-projects and main material components (2006-2008, USD, some are designed cost)*

*Macro-projects:*

1. Oil line 467 km - \$2.2B. (4.7M/km).
2. Oil line 120 km \$0.7B. (5.8M/km).
3. Oil line (Byrgas-Aleksandropolus) (Black-Sea) 280 km - \$1.2B. (4.3M/km).
4. East oil line 4188 km - \$11.2B (2.67M/km),(2008).
5. Oil line Azerbaijan – Turkey 1767 km - \$4B. (2.26M/km).
6. Gas line “Blue Stream” (Russia – Turkey) (under water of Black Sea, deep 2150m) - \$3.2B.
7. Gas line 530 km (gas capacity 30B cub, m gas per year) more \$1B.
8. MagLev (Magnetic Levitation Highway) in Shanghai, China, 30 km – 1.2B.



9. MagLeb 1 km – \$24.6M/km.
10. Highway system 8 lines - \$50M/mile (USA).
11. Airport Hong Kong - \$20B (1998).
12. Sea bridge 25 km (Jersey (England)-France) - \$2B (project).
13. Bridge (China) 36 km - \$1.55B.
14. Canal Caspian Sea -Black Sea 750 km, caring capacity 32M tons, - \$6.5B.
15. Tunnel English-France 50 km, - \$12B.
16. Tunnel Russia-USA 100 km \$10-12B (Bering Str., project).
17. 1 km railway in Siberia (permafrost) \$11M (1 km conventional railway \$0.8-1.3M/km).
18. Wind electric plant 50MW cost \$80-100M.
19. Solar electric plant 250MW cost \$300M.
20. Nuclear electric plant (“Belene”, Bulgaria) 2000MW cost \$6B, building 7 years.
21. Floating nuclear electric plant 70MW cost \$200M, building 4 years.
22. Nuclear reactor RBEP-1000 cost \$1B.

*Materials:*

23. Steel tube for gas (diameter 1420mm, wall thickness 19 mm, mark 17G1C) \$712/ton, \$470/m (2006).
24. Steel tube for gas (diameter 750mm, thickness 7-9 mm, mark 17G1C) \$440/ton, (2006).
25. Steel tube for gas (diameter 273mm, thickness 5-6 mm, mark 17G1C) \$1000/ton, (2006).
26. Plastic tube for cold water (diameter 125 mm, thickness 11.4 mm, mark PN1) \$8/m.

*Aircraft (2007):*

27. C-17 Clobemaster (military-transport) \$250M.
28. A-380 big passenger aircraft \$320M.
29. Mig-29K (military fighter) \$35M.
30. Su-34 (attack plane) \$40M.
31. Tu-204 (cargo) \$40M.
32. Typhoon (fighter, English) \$120M.

## ***Non-conventional Materials***

### **Artificial Fiber and Nanotubes**

*Artificial fiber and cable (film) properties.* Cheap artificial fibers are currently being manufactured, which have tensile strengths of 3-5 times more than steel and densities 4-5 times less than steel. There are also experimental fibers (whiskers) that have tensile strengths 30-100 times more than steel and densities 2 to 5 times less than steel. For example, in the book [172] Ch.12A, p.158 (1989), there is a fiber (whisker)  $C_D$ , which has a tensile strength of  $\sigma = 8000 \text{ kg/mm}^2$  and density (specific gravity) of  $\gamma = 3.5 \text{ g/cm}^3$ . If we use an estimated strength of  $3500 \text{ kg/mm}^2$  ( $\sigma = 7 \cdot 10^{10} \text{ N/m}^2$ ,  $\gamma = 3500 \text{ kg/m}^3$ ), then the ratio is  $\gamma/\sigma = 0.1 \times 10^{-6}$  or  $\sigma/\gamma = 10 \times 10^6$ .

Nanotubes come close to being the best fiber that can be made from graphite (see section “Nanotubes” in book Attachment).

For example, whiskers of Carbon nanotube (CNT) material have a tensile strength of 200 Giga-Pascals and a Young’s modulus over 1 Tera Pascals (1999). The theory predicts 1 Tera Pascals and a Young’s modulus of 1-5 Tera Pascals. The hollow structure of nanotubes makes them very light (the specific density varies from 0.8 g/cc for SWNT’s (Single Wall Nano Tubes) up to 1.8 g/cc for MWNT’s, compared to 2.26 g/cc for graphite or 7.8 g/cc for steel). Tensile strength of MWNT’s nanotubes reaches 150 GPa.

In 2000, a multi-walled carbon nanotube was tested to have a tensile strength of 63 GPa. Since carbon nanotubes have a low density for a solid of 1.3-1.4 g/cm<sup>3</sup>, its specific strength of up to 48,000 kN·m/kg is the best of known materials, compared to high-carbon steel’s 154 kN·m/kg. The theory predicts the tensile stress of different types of nanotubes as: Armchair SWNT - 120 GPa, Zigzag SWNT – 94 GPa.

About 60 tons/year of nanotubes are produced now (2007). Price is about \$100 - 50,000/kg. Experts predict production of nanotubes on the order of 6000 tons/year and with a price of \$1 – 100/kg to 2012.

Commercial artificial fibers are cheap and widely used in tires and countless other applications. The authors have found only older information about textile fiber for inflatable structures (Harris J.T., Advanced Material and Assembly Methods for Inflatable Structures, AIAA, Paper No. 73-448, 1973). This refers to DuPont textile Fiber B and Fiber PRD-49 for tire cord. They are 6 times strong as steel (psi is 400,000 or 312 kg/mm<sup>2</sup>) with a specific gravity of only 1.5. Minimum available yarn size (denier) is 200, tensile module is  $8.8 \times 10^6$  (B) and  $20 \times 10^6$  (PRD-49), and ultimate elongation (percent) is 4 (B) and 1.9 (PRD-49). Some data are in Table 5 Attn.

Industrial fibers have up to  $\sigma = 500 - 600 \text{ kg/mm}^2$ ,  $\gamma = 1500 - 1800 \text{ kg/m}^3$ , and  $\sigma/\gamma = 2,78 \times 10^6$ . But we are projecting use in the most present projects the cheapest films and cables applicable (safety  $\sigma = 100 - 200 \text{ kg/mm}^2$ ).

## Aerogel

*Aerogel* is a low-density solid-state material derived from gel in which the liquid component of the gel has been replaced with gas. The result is an extremely low density solid with several remarkable properties, most notably its effectiveness as a thermal insulator.

*Silica aerogel* is an especially good conductive insulator because silica is a poor conductor of heat—a metallic aerogel, on the other hand, would be a less effective insulator. Carbon aerogel is a good radiative insulator because carbon absorbs the infrared radiation that transfers heat. The most insulative aerogel is silica aerogel with carbon added to it.

Since it is 99.8% air, it appears semi-transparent. The world’s lowest-density solid is a silica nanofoam at 1 mg/cm<sup>3</sup>, which is the evacuated version of the record-aerogel of 1.9 mg/cm<sup>3</sup>. The density of air is 1.2 mg/cm<sup>3</sup>. It has remarkable thermal insulative properties, having an extremely low thermal conductivity: from 0.03 W/mK down to 0.004 W/mK, Its melting point is 1,473 K (1,200 °C or 2,192 °F).

*Carbon aerogels*. Due to their extremely high surface area, carbon aerogels are used to create supercapacitors, with values ranging up to thousands of farads based on a capacitance of 104 F/g and 77 F/cm<sup>3</sup>. Carbon aerogels are also extremely "black" in the infrared spectrum, reflecting only 0.3% of radiation between 250 nm and 14.3 μm, making them efficient for solar energy collectors.

### **Super-alloys**

A *superalloy*, or *high-performance alloy*, is an alloy that exhibits excellent mechanical strength and creep resistance at high temperatures, good surface stability, and corrosion and oxidation resistance. They can operate up to 1100 °C (1373 K).

Superalloys are metallic materials for service at high temperatures, particularly in the hot zones of gas turbines. Such materials allow the turbine to operate more efficiently by withstanding higher temperatures. Turbine Inlet Temperature (TIT), which is a direct indicator of the efficiency of a gas turbine engine, depends on the temperature capability of 1st stage high pressure turbine blade made of Ni base superalloys exclusively.

One of the most important superalloy properties is high temperature creep resistance. Other crucial material properties are fatigue life, phase stability, as well as oxidation and corrosion resistance.

### **Metal Foam**

A metal foam is a cellular structure consisting of a solid metal - frequently aluminum - containing a large volume fraction of gas-filled pores. The pores can be sealed (closed-cell foam), or they can form an interconnected network (open-cell foam). The defining characteristic of metal foams is a very high porosity: typically 75-95% of the volume consists of void spaces. The strength of foamed metal possesses a power law relationship to its density; i.e. 20% dense material is more than twice as strong as 10% dense material (*Ceteris paribus*).

Closed-cell foams retain the fire resistant and recycling capability of other metallic foams but add an ability to float in water (for densities less than 1g/cc).

### **Meta-material**

A metamaterial (or meta-material) is a material which gains its properties from its structure rather than directly from its composition. To distinguish metamaterials from other composite materials, the *metamaterial* label is usually used for a material which has unusual properties.

### **Mylar (boPET)**

Biaxially-oriented polyethylene terephthalate (boPET) polyester film is used for its high tensile strength, chemical and dimensional stability, transparency, reflective, gas and aroma barrier properties and electrical insulation.

A variety of companies manufacture boPET and other polyester films under different trade names. In the USA and the UK, the most well-known trade names are *Mylar* and *Melinex*.

The orientation of the polymer chains is responsible for the high strength and stiffness of biaxially oriented PET film, which has a typical Young's modulus of about 4 GPa. biaxially oriented PET film has excellent clarity, despite its semicrystalline structure.

Biaxially oriented PET film can be aluminized by evaporating a thin film of metal onto it. The result is much less permeable to gasses (important in food packaging) and reflects up to 99% of light, including much of the infrared spectrum.

Mylar is base material for audio or video magnetic recording tapes.

Five layers of metallized boPET film in the NASA's spacesuits make them radiation resistant and help to keep astronauts warm.

### **Kapton**

*Kapton* is a polyimide film developed by DuPont which can remain stable in a wide range of temperatures, from -269 °C to +400 °C (4 K - 673 K). Kapton is used in, among other things,

flexible printed circuits (flexible electronics) and Thermal Micrometeoroid Garments, the outside layer of spacesuits.

According to a NASA internal report, Space Shuttle "wires were coated with an insulator known as Kapton that tended to break-down over time, causing electrical short-circuits and, potentially, fires. "The NASA Jet Propulsion Laboratory has considered Kapton as a good plastic support for solar sails because of its long duration in the space environment" (J. L. Wright, *Space Sailing*, Gordon and Breach, 1992).

## Nylon

Nylon is one of the most common polymers and is technically a synthetic linen.

Property are: density 1.15 g/cm<sup>3</sup>; electric conductivity 10<sup>-12</sup> S/m; melting point 190-350°C; tensile stress up 50 kgf/mm<sup>2</sup>.

*Characteristics:*

- Variation of luster: nylon has the ability to be very lustrous, semilustrous or dull.
- Durability: its high tenacity fibers are used for seatbelts, tire cords, ballistic cloth and other uses.
- High elongation
- Excellent abrasion resistance
- Highly resilient (nylon fabrics are heat-set)
- Paved the way for easy-care garments
- High resistance to:
  - insects, fungi and animals
  - molds, mildew, rot
  - many chemicals
- Melts instead of burning
- Used in many military applications

## Kevlar

*Kevlar* is the registered trademark for a light, strong para-aramid synthetic fiber, related to other aramids such as Nomex and Technora. Typically it is spun into ropes or fabric sheets that can be used as such or as an ingredient in composite material components.

Currently, Kevlar has many applications, ranging from bicycle tires and racing sails to body armor because of its high strength-to-weight ratio—famously: "...5 times stronger than steel on an equal weight basis..." A similar fibre called Twaron with roughly the same chemical structure was introduced by Akzo in 1978, and now manufactured by Teijin.

When Kevlar is spun, the resulting fibre has great tensile strength (ca. 3 000 MPa), and a relative density of 1.44. When used as a woven material, it is suitable for mooring lines and other underwater application objects.

There are three grades of Kevlar: (i) Kevlar, (ii) Kevlar 29, and (iii) Kevlar 49. Typically, Kevlar is used as reinforcement in tires and rubber mechanical goods. Kevlar 29's industrial applications are as cables, in asbestos replacement, brake linings, and body armour. Kevlar 49 has the greatest tensile strength of all the aramids, and is used in plastic reinforcement for boat hulls, airplanes, and bicycles. The ultraviolet light component of sunlight degrades and decomposes Kevlar, a problem known as UV degradation, and so it is rarely used outdoors without protection against sunlight.

For a polymer Kevlar has very good resistance to high temperatures, and maintains its strength and resilience down to cryogenic temperatures ( $-196^{\circ}\text{C}$ ); indeed, it is slightly stronger at low temperatures. At higher temperatures the tensile strength is immediately reduced by about 10-20%, and after some hours the strength progressively reduces further. For example at  $160^{\circ}\text{C}$  about 10% reduction in strength occurs after 500 hours. At  $260^{\circ}\text{C}$  50% reduction occurs after 70 hours. At  $450^{\circ}\text{C}$  Kevlar sublimates.

### **Applications**

*Armor.* Kevlar is well-known as a component of some bulletproof vests and bulletproof facemasks. The PASGT helmet and vest used by US military forces since the early 1980s both have Kevlar as a key component, as do their replacements. Other military uses include bulletproof facemasks used by sentries. Civilian applications include Kevlar reinforced clothing for motorcycle riders to protect against abrasion injuries and also Emergency Service's protection gear if it involves high heat (e.g., tackling a fire), and Kevlar body armor such as vests for Police officers, security, and S.W.A.T.

*Rope and cable.* The fibre is used in woven rope and in cable, where the fibres are kept parallel within a polyethylene sleeve. Known as "Parafil", the cables have been used in small suspension bridges such as the bridge at Aberfeldy in Scotland. They have also been used to stabilise cracking concrete cooling towers by circumferential application followed by tensioning to close the cracks.

*Building construction.* A retractable roof of over 5,575 square meter of area, made of Kevlar, was a key part of the design of Montreal's Olympic stadium for the 1976 Summer Olympics held in Canada. It was spectacularly unsuccessful: completed ten years late and replaced ten years later in May 1998 after a series of problems.

*Composite materials.* Aramid fibres are widely used for reinforcing composite materials, often in combination with carbon fibre and glass fibre. The matrix for high performance composites is usually epoxy resin. Typical applications include monocoque bodies for F1 racing cars, and helicopter rotor blades.

## GENERAL REFERENCES

(Parts of these works are available from the Internet: <http://Bolonkin.narod.ru/p65.htm> , <http://arxiv.org> , <http://www.scribd.com> search term: "Bolonkin"; in book “*Non-Rocket Space Launch and Flight*”, Elsevier, 2006, 488 pgs; in book “*New Concepts, Ideas, and Innovations in Aerospace and Technology*”, NOVA, 2007, 502 pgs; in book “*Macro-Projects: Environment and Technologies*”, NOVA, 2008, 536 pgs.)

- [1] Bolonkin, A.A., (1958a). Design of Hydro-Aircraft with Underwater Wing. *Report of Aircraft State Construction Bureau named Antonov*, Kiev, Ukraine, 1959 (in Russian), 120 p.
- [2] Bolonkin, A.A., (1959a). Investigation of Aircraft AN-12 in Take-off. *Report of Aircraft State Construction Bureau named Antonov*, Kiev, Ukraine, 1959 (in Russian), 60 p.
- [3] Bolonkin, A.A., (1959b). Research of Optimal Parameters of VTOL Aircraft, *Report of Aircraft State Construction Bureau named Antonov*, Kiev, 1959 (in Russian), Part 1 40 p., part 2 35 p.
- [4] Bolonkin, A.A., (1959c). Research of Optimal Parameters of High Altitude Aircraft. *Report of Aircraft State Construction Bureau named Antonov*, Kiev, Ukraine, 1959 (in Russian), 60 p.
- [5] Bolonkin, A.A., (1959d). Computation of High Thrust Aircraft with unsteady polar. *Report of Aircraft State Construction Bureau named Antonov*, Kiev, Ukraine, 1959 (in Russian), 50 p.
- [6] Bolonkin, A.A., (1960a). Method of Estimation the Control of Aircraft Interface. *Presiding of Kiev High Engineering Aviation Military School (KVIAVU)*, Kiev, Ukraine, Issue #72, 1960.
- [7] Bolonkin, A.A., (1962a), *Theory of Flight Models*, Moscow, Association of Army, Air Force, and NAVY, 328p. 1962, (in Russian).
- [8] Bolonkin, A.A., (1964a). Optimization of parameters of variation problems (Ukrainian. Russian and English summaries). *Dopoviti Akad. Nauk Ukrain. RSR*, 1964, #5, p. 580-582. Math.Rev. #6352.
- [9] Bolonkin, A.A., (1964b) The calculus of variations and a functional equation of Bellman, and an interpretation of Langrange’s undetermined multipliers. (Ukrainian. Russian and English summaries). *Dopovidi Akad. Nauk Ukrain., RSR* 1964, #10, p. 1290-1293. M.R. #5136.
- [10] Bolonkin, A.A., (1964c). The extension principle and the Jacobi condition of the variation calculus. (Ukrainian. Russian and English summaries). *Dopovidi Akad. Nauk Ukrain. RSR* 1964. #7. p. 849-853. M.R. #5117.
- [11] Bolonkin, A.A., (1965a), “Theory of Flight Vehicles with Control Radial Force”. Collection *Researches of Flight Dynamics*, Mashinostroenie Publisher, Moscow, pp. 79–118, 1965, (in Russian). Intern.Aerospace Abstract A66-23338# (Eng).

- [12] Bolonkin, A.A., (1965b), Investigation of the Take off Dynamics of a VTOL Aircraft. Collection *Researches of Flight Dynamics*. Moscow, Mashinostroenie Publisher, 1965, pp. 119-147 (in Russian). International Aerospace Abstract A66-23339# (English).
- [13] Bolonkin, A.A., (1965c), Optimization of Trajectories of Multistage Rockets. Collection *Researches of Flight Dynamics*. Moscow, 1965, p. 20-78 (in Russian). International Aerospace Abstract A66-23337# (English).
- [14] Bolonkin, A.A., (1965d). A method for the solution of optimal problems (Russian). Collection *Complex Systems Control*, pp.34-67. Naukova Dumka, Kiev, 1965. M.R. #5535.
- [15] Bolonkin, A.A., (1965e). Special, Sliding, and Impulse Regimes in Problems of Flight Dynamics (Russian). Collection *Complex Systems Control*, pp.68-90. Naukova Dumka, Kiev, 1965. M.R. #5535.
- [16] Bolonkin, A.A., (1966a). Boundary-value problems of Optimal Control. *Military Aviation Engineering Academy (VVIA) named Zhukovskii*, Issue #1131, 1966, p. 103-128. (Russian).
- [17] Bolonkin, A.A., (1967a). Special extreme, *Report presented to Symposium of Applied Mathematics*, Gorkii, USSR, 1967. (Russian).
- [18] Bolonkin, A.A., (1968a). Impulse solution in control problems. (Russian). *Izv. Sibirsk. Otdel. Akad. Nayk USSR*, 1968, No. 13, p. 63-68. M.R. 7568. (Russian).
- [19] Bolonkin, A.A., (1968b). Solution of Problem the Linear Optimal Control with one Control, *Journal "Prikladnaya Mekhanika"*, Vol. 4, #4, 1968, p.111-121. (Russian).
- [20] Bolonkin, A.A., (1969a). Solution of discrete problems of optimal control on the basis of a general minimum principle (Russian. English summary). *Vycisl. Prikl. Mat. (Kiev) Vyp. 7 (1969)*, 121-132. Mathematical Review 771.
- [21] Bolonkin, A.A., (1969b), Special extreme in optimal control. *Akademia Nauk USSR, Izvestiya. Tekhnicheskaya Kibernetika*, No 2, Mar-Apr.,1969, p.187-198. See also *English translation in Engineering Cybernetics*, # 2, Mar- Apr.1969, p.170-183, (English).
- [22] Bolonkin, A.A., (1970a). A certain method of solving optimal problems. *Izv. Sibirsk. Otdel. Akad. Nauk SSSR*. 1970, no.8, p. 86-92. M.R. #6163.
- [23] Bolonkin, A.A., (1970b). A certain approach to the solution of optimal problems. (Russian. English summary). *Vycisl. Prikl. Mat. (Kiev)*. Vyp. 12 (1970), p. 123-133. M.R. #7940.
- [24] Bolonkin, A.A., (1971a), *Solution Methods for boundary-value problems of Optimal Control Theory*. Translated from *Prikladnaya Mekhanika*, Vol. 7, No 6, 1971, p. 639-650, (in English).
- [25] Bolonkin, A.A., (1971b). Solution of Optimal Problems. *Collection "Mathematical Problems of Production Control"*, Moscow State University (MGU), Issue #3, 1971, p. 55-67.
- [26] Bolonkin, A.A., (1972a), *New Methods of Optimization and their Applications*, Moscow Highest Technology University named Bauman, 1972, p.220 (in Russian).
- [27] Bolonkin, A.A., (1982a), *Installation for Open Electrostatic Field*, Russian patent application #3467270/21 116676, 9 July, 1982 (in Russian), Russian PTO.
- [28] Bolonkin, A.A., (1982b), *Radioisotope Propulsion*. Russian patent application #3467762/25 116952, 9 July 1982 (in Russian), Russian PTO.



- [29] Bolonkin, A.A., (1982c), *Radioisotope Electric Generator*. Russian patent application #3469511/25 116927. 9 July 1982 (in Russian), Russian PTO.
- [30] Bolonkin, A.A., (1983a), *Space Propulsion Using Solar Wing and Installation for It*, Russian patent application #3635955/23 126453, 19 August, 1983 (in Russian), Russian PTO.
- [31] Bolonkin, A.A., (1983b), *Getting of Electric Energy from Space and Installation for It*, Russian patent application #3638699/25 126303, 19 August, 1983 (in Russian), Russian PTO.
- [32] Bolonkin, A.A., (1983c), *Protection from Charged Particles in Space and Installation for It*, Russian patent application #3644168 136270, 23 September 1983, (in Russian), Russian PTO.
- [33] Bolonkin, A. A., (1983d), *Method of Transformation of Plasma Energy in Electric Current and Installation for It*. Russian patent application #3647344 136681 of 27 July 1983 (in Russian), Russian PTO.
- [34] Bolonkin, A. A., (1983e), *Method of Propulsion using Radioisotope Energy and Installation for It*. of Plasma Energy in Electric Current and Installation for it. Russian patent application #3601164/25 086973 of 6 June, 1983 (in Russian), Russian PTO.
- [35] Bolonkin, A. A.,(1983f), *Transformation of Energy of Rarefaction Plasma in Electric Current and Installation for it*. Russian patent application #3663911/25 159775, 23 November 1983 (in Russian), Russian PTO.
- [36] Bolonkin, A. A., (1983g), *Method of a Keeping of a Neutral Plasma and Installation for it*. Russian patent application #3600272/25 086993, 6 June 1983 (in Russian), Russian PTO.
- [37] Bolonkin, A.A., (1983h), *Radioisotope Electric Generator*. Russian patent application #3620051/25 108943, 13 July 1983 (in Russian), Russian PTO.
- [38] Bolonkin, A.A., (1983i), *Method of Energy Transformation of Radioisotope Matter in Electricity and Installation for it*. Russian patent application #3647343/25 136692, 27 July 1983 (in Russian), Russian PTO.
- [39] Bolonkin, A.A., (1983j). *Method of stretching of thin film*. Russian patent application #3646689/10 138085, 28 September 1983 (in Russian), Russian PTO.
- [40] Bolonkin, A.A., (1984a). Method Solution of Optimal Problem, Collection "*Research of Computer and Control System*", Irkutsk, USSR, 1984, pp.94-98. (in Russian).
- [41] Bolonkin, A.A., (1987a). Method of Deformation of Extreme. Collection "*Methods and Programs of Optimal Problems in Networks*", Irkutsk State University and West Siberian Technological Institute, 1987, (in Russian).
- [42] Bolonkin, A.A., (1987b). Method for Solution of Optimal Problems having equalities and non-equalities limitations. Collection "*Methods and Programs of Optimal Problems in Networks*", Irkutsk State University and West Siberian Technological Institute, 1987, (in Russian).
- [43] Bolonkin A.A., (1988a). Application of the Deformation Method to Optimization Problems on any Set" (in Russian), Collection "*Design of Micro-processors*", Irkutsk (USSR), 1988 9 p.
- [44] Bolonkin, A.A., Global Method Optimization on any Set" (in Russian), Collection "*Design of Micro-processors*", Irkutsk (USSR), 1988, 9 p.

- [45] Bolonkin, A.A., (1988b). Deformation Method in Control Problems" (in Russian), Collection "*Design of Micro-processors*", Irkutsk (USSR), 1988 10 p.
- [46] Bolonkin, A.A., (1990a). "Aviation, Motor and Space Designs", Collection *Emerging Technology in the Soviet Union*, 1990, Delphic Ass., Inc., pp.32–80 (English).
- [47] Bolonkin, A.A., (1991a), *The Development of Soviet Rocket Engines*, 1991, Delphic Assoc. Inc., 122 p. Washington, (in English).
- [48] Bolonkin, A.A., (1991b), New Approach to Finding a Global Optimum. *New American's Collected Scientific Reports*. Vol. 1, 1991, The Bnai Zion Scientists Division., New York.
- [49] Bolonkin, A.A., (1992a), "A Space Motor Using Solar Wind Energy (Magnetic Particle Sail)". The World Space Congress, Washington, DC, USA, 28 Aug. – 5 Sept., 1992, IAF-0615.
- [50] Bolonkin, A.A., (1992b), "Space Electric Generator, run by Solar Wing". The World Space Congress, Washington, DC, USA, 28 Aug. –5 Sept. 1992, IAF-92-0604.
- [51] Bolonkin, A.A., (1992c), "Simple Space Nuclear Reactor Motors and Electric Generators Running on Radioactive Substances", The World Space Congress, Washington, DC, USA, 28 Aug. – 5 Sept., 1992, IAF-92-0573.
- [52] Bolonkin, A.A., *The Twenty - First Century: The advent of the non-biological civilization*. GOTO: <http://Bolonkin.narod.ru>.
- [53] Bolonkin, A.A. (1994a), "The Simplest Space Electric Generator and Motor with Control Energy and Thrust", 45th International Astronautical Congress, Jerusalem, Israel, 9–14 Oct., 1994, IAF-94-R.1.368.
- [54] Bolonkin, A.A., Khot N., (1994b), *Optimal Structural and Control Design*. 45th International Actronautical Congress. Jerusalem, Israel. October 9-14, 1994, IAF-94-I.4.206.
- [55] Bolonkin, A.A., (1994c), *Method for Finding a Global Minimum*, AIAA/NASA/USAF/SSMO Symposium on Multi-disciplinary Analysis and Optimization, Panama City, Florida, USA, Sept. 7-9, 1994.
- [56] Bolonkin, A.A. and Khot, N., (1995a), Design and Optimal Control in Smart Structures. Conference "Mathematics and Control in Smart Structures", 26 Feb.-3 March 1995, San Diego, CA, USA.
- [57] Bolonkin, A.A., Khot N., (1995b), *Optimum Structural Vibration Control with Bounds on Control Forces*, 1995 ASME Design Technical Conference, 15th Biennial Conference on Vibration and Noise, September 17-21,1995, Boston, MA, USA.
- [58] Bolonkin, A.A., (1995c), *The Twenty - First Century - the beginning of human immortality*. GOTO: <http://Bolonkin.narod.ru>.
- [59] Bolonkin, A.A., Khot N., (1996a), *Optimal Bounded Control Design for Vibration Suppression*. *Acta Astronautics*, Vol.38, No. 10, pp803-813, 1996.
- [60] Bolonkin, A.A. and Khot N., (1996b), *Minimum Weight of Control Devices with Bounded LQG Control*. The World Space Congress -96, June 1-6, 1996, Albuquerque, MN, USA.
- [61] Bolonkin, A.A. and Khot N., (1996c), *Design of Smart Structures with Bounded Controls, Smart Structures and Materials*, Feb. 25-29, 1996, San-Diego, CA.

- [62] Bolonkin, A.A. and Khot N., (1997a), Design of Structure control System using Bounded LQG, *Eng. Opt.*, 1997, Vol. 29, pp. 347-358.
- [63] Bolonkin, A.A., (1997b). *Eccentric internal combustion engine*. Patent application US PTO 08/892,665 of 07/14/97.
- [64] Bolonkin, A.A., (1998a). *Inflatable flight vehicles*. Patent application US PTO 09/271,700 of 1/26/98.
- [65] Bolonkin, A.A., (1998b). *Protection from Tornado*. Patent application US PTO 09/236,749 of 1/25/98.
- [66] Bolonkin, A.A., (1998c). *Uniblade Rotor*, Patent application US PTO 09/203,130 of 2/01/98. Patent US 6,234,422 of 5/22/01.
- [67] Bolonkin, A.A., (1999a). *Method of space launch and hypersonic launch system*. Patent application US PTO 09/344,235 of 6/25/99.
- [68] Bolonkin, A.A. (1999b), A High Efficiency Fuselage propeller (“Fusefan”) for Subsonic Aircraft, 1999 World Aviation Congress, AIAA, #1999-01-5569.
- [69] Bolonkin, A.A. and Gilyard, G.B., (1999c), Estimated Benefits of Variable-Geometry Wing Camber Control for Transport Aircraft. *NASA Center for AeroSpace Information (CASI), NASA/TM-1999-206586; H-2368; NAS 1.15:206586, 19991001; October 1999*
- [70] Bolonkin, A.A., (1999d). The twenty-first century: the advent of the non-biological civilization and the future of the human race, *Journal “Kybernetes”*, Vol. 28, No.3, 1999, pp. 325-334, MCB University Press, 0368-492 (English).
- [71] Bolonkin A.A., (1999e). *Science, Soul, Heaven and Supreme Mind*, <http://Bolonkin.narod.ru> (Russian, English).
- [72] Bolonkin, A.A., (1999f). *Breakthrough in Immortality*. <http://Bolonkin.narod.ru> (Russian, English).
- [73] Bolonkin, A.A., (1999g). *Human Immortality and Electronic Civilization*. Electronic book, 1999. WEB: <http://Bolonkin.narod.ru>, <http://Bolonkin.narod.ru/p101.htm> (English), <http://Bolonkin.narod.ru/p100.htm> (Russian).
- [74] Bolonkin, A.A., (1999h). *Bolonkin Rotor Engine*. Patent application US PTO 09/290,465 of 04/12/99. Patent US 6,248,921 of 10/09/01
- [75] Bolonkin, A.A., (1999i). *Hypersonic Space Launcher (Method and Installation)* Patent application US PTO 09/13,08 of 1/26/98; 09/344,235 of 06/25/99; 1/057,819 of 01/18/02.
- [76] Bolonkin, A.A., Gilyard G.B., (2000a), *Optimal Pitch Thrust-Vector Angle and Benefits for all Flight Regimes*, *NASA Center for AeroSpace Information (CASI), NASA/TM-2000-209021; NAS 1.15:209021; H-2402, 20000301; March 2000*.
- [77] Bolonkin, A.A., (2000b). *Eccentric Engine*. Patent application US PTO 09/575,256 of 05/22/2000. Patent US 6,526,937 B1 of 3/4/03.
- [78] Bolonkin, A.A., (2001a). *Method and Installation for Space Trip*. Patent application US PTO 09/789,959 of 2/23/01.
- [79] Bolonkin, A.A., (2001b). *Method and Installation for Space Launch*. Patent application US PTO 09/873,985 of 6/04/01.
- [80] Bolonkin, A.A., (2001c). *"Method Transportation of Vehicles and Installations for It"*. Patent application US PTO 09/893,060 of 6/28/01. Patent US 6,434,143 B1 of 12/17/02.

- [81] Bolonkin, A.A., (2001d). *Method and Installation for getting of Energy*. Patent application US PTO 09/945,497 of 9/06/01.
- [82] Bolonkin, A.A., (2001e). "*Method for Gas and Payload Transportation at Long Distance and Installations for It*", Patent Application USPTO # 09/978,507 of 10/18/01.
- [83] Bolonkin, A.A., (2001f). Cable Launcher. Patent application US PTO 09/974,670 of 10/11/01.
- [84] Bolonkin, A.A., (2002a), "*Non-Rocket Space Rope Launcher for People*", IAC-02-V.P.06, 53rd International Astronautical Congress, The World Space Congress – 2002, 10–19 Oct 2002, Houston, Texas, USA.
- [85] Bolonkin, A.A., (2002b), "*Non-Rocket Missile Rope Launcher*", IAC-02-IAA.S.P.14, 53rd International Astronautical Congress, The World Space Congress – 2002, 10–19 Oct 2002, Houston, Texas, USA.
- [86] Bolonkin, A.A., (2002c), "*Inexpensive Cable Space Launcher of High Capability*", IAC-02-V.P.07, 53rd International Astronautical Congress, The World Space Congress – 2002, 10–19 Oct 2002, Houston, Texas, USA.
- [87] Bolonkin, A.A., (2002d), "*Hypersonic Launch System of Capability up 500 tons per day and Delivery Cost \$1 per Lb*". IAC-02-S.P.15, 53rd International Astronautical Congress, The World Space Congress – 2002, 10–19 Oct 2002, Houston, Texas, USA.
- [88] Bolonkin, A.A., (2002e), "*Employment Asteroids for Movement of Space Ship and Probes*". IAC-02-S.6.04, 53rd International Astronautical Congress, The World Space Congress – 2002, 10–19 Oct 2002, Houston, Texas, USA.
- [89] Bolonkin, A.A., (2002f), "*Optimal Inflatable Space Towers of High Height*". COSPAR-02 C1.1-0035-02, 34th Scientific Assembly of the Committee on Space Research (COSPAR), The World Space Congress – 2002, 10–19 Oct 2002, Houston, Texas, USA.
- [90] Bolonkin, A.A., (2002g), "*Non-Rocket Earth-Moon Transport System*", COSPAR-02 B0.3-F3.3-0032-02, 02-A-02226, 34th Scientific Assembly of the Committee on Space Research (COSPAR), The World Space Congress – 2002, 10–19 Oct 2002, Houston, Texas, USA.
- [91] Bolonkin, A.A., (2002h) "*Non-Rocket Earth-Mars Transport System*", COSPAR-02 B0.4-C3.4-0036-02, 34th Scientific Assembly of the Committee on Space Research (COSPAR), The World Space Congress – 2002, 10–19 Oct 2002, Houston, Texas, USA.
- [92] Bolonkin, A.A., (2002i). "*Transport System for Delivery Tourists at Altitude 140 km*". IAC-02-IAA.1.3.03, 53rd International Astronautical Congress, The World Space Congress – 2002, 10-19 Oct. 2002, Houston, Texas, USA.
- [93] Bolonkin, A.A., (2002j), "*Hypersonic Gas-Rocket Launch System.*" AIAA-2002-3927, 38th AIAA/ASME/SAE/ASEE Joint Propulsion Conference and Exhibit, 7–10 July 2002. Indianapolis, IN, USA.
- [94] Bolonkin, A.A., Cloutier D., (2002k). Search, Observation, and Attack Problems, *Technical Report AFRL-MN-EG-TR-2003-1717*, 21p. 2002.
- [95] Bolonkin, A.A., (2003a), "Air Cable Transport", *Journal of Aircraft*, Vol. 40, No. 2, March–April 2003, pp.265-269.
- [96] Bolonkin, A.A., (2003b), "Optimal Inflatable Space Towers with 3-100 km Height", *Journal of the British Interplanetray Society*, Vol. 56, No 3/4, pp. 87–97, 2003.

- [97] Bolonkin, A.A., (2003c), “Asteroids as Propulsion Systems of Space Ships”, *Journal of the British Interplanetary Society*, Vol. 56, No 3/4, pp. 97–107, 2003.
- [98] Bolonkin, A.A., (2003d), “Non-Rocket Transportation System for Space Travel”, *JBIS*, Vol. 56, No 7/8, pp. 231–249, 2003.
- [99] Bolonkin, A.A., (2003e), “Hypersonic Space Launcher of High Capability”, *Actual problems of aviation and aerospace systems*, Kazan, No. 1(15), Vol. 8, 2003, pp. 45–58. Kazan Aviation Institute.
- [100] Bolonkin, A.A., (2003f), “Centrifugal Keeper for Space Stations and Satellites”, *JBIS*, Vol. 56, No 9/10, pp. 314–327, 2003.
- [101] Bolonkin, A.A., (2003g), “Non-Rocket Earth-Moon Transport System”, *Advances in Space Research*, Vol. 31/11, pp. 2485–2490, 2003, Elsevier, London.
- [102] Bolonkin, A.A., (2003h), “Earth Accelerator for Space Ships and Missiles”. *Journal of the British Interplanetary Society*, Vol. 56, No. 11/12, 2003, pp. 394–404.
- [103] Bolonkin, A.A., (2003i), “Air Cable Transport and Bridges”, TN 7567, International Air and Space Symposium – The Next 100 Years, 14–17 July 2003, Dayton, Ohio, USA.
- [104] Bolonkin, A.A., (2003j), “Air Cable Transport System”, *Journal of Aircraft*, Vol. 40, No. 2, March-April 2003, pp. 265-269.
- [105] Bolonkin, A.A., Sierakowski R., (2003k). *Design of Optimal Regulators*. The manuscript is accepted as paper AIAA-2003-6638 by 2<sup>nd</sup> AIAA “Unmanned Unlimited“ Systems, Technologies, and Operations- Aerospace, Land, and Sea Conference and Workshop and Exhibit, San Diego, California, USA, 15-18 Sep 2003. GOTO: <http://arxiv.org> and search "Bolonkin".
- [106] Bolonkin, A.A., Murphy R., (2003-l). *Geometry-Based Feasibility Constraints for Single Pursuer Multiple Evader Problems*, 2nd AIAA “Unmanned Unlimited” Systems, Technologies, and Operations – Aerospace, Land, and sea Conference and Workshop and Exhibit, San Diego, California, 15-18 Sep 2003, AIAA-2003-6638.
- [107] Bolonkin, A.A., (2004a), “Kinetic Space Towers and Launchers ‘, *JBIS*, Vol. 57, No 1/2, pp. 33–39, 2004.
- [108] Bolonkin, A.A., (2004b), “Optimal trajectory of air vehicles”, *Aircraft Engineering and Space Technology*, Vol. 76, No. 2, 2004, pp. 193–214.
- [109] Bolonkin, A.A., (2004c), “Long Distance Transfer of Mechanical Energy”, International Energy Conversion Engineering Conference at Providence RI, Aug. 16–19, 2004, AIAA-2004-5660.
- [110] Bolonkin, A.A., (2004d), “Light Multi-Reflex Engine”, *Journal JBIS*, Vol. 57, No 9/10, pp. 353–359, 2004.
- [111] Bolonkin, A.A., (2004e), “Optimal trajectory of air and space vehicles”, *AEAT*, No 2, pp. 193–214, 2004.
- [112] Bolonkin, A.A., (2004f), “Hypersonic Gas-Rocket Launcher of High Capacity”, *Journal of the British Interplanetary Society*, Vol. 57, No 5/6, pp. 167–172, 2004.
- [113] Bolonkin, A.A., (2004g), “High Efficiency Transfer of Mechanical Energy”. International Energy Conversion Engineering Conference at Providence RI, USA. 16–19 August, 2004, AIAA-2004-5660.

- [114] Bolonkin, A.A., (2004h), “Multi-Reflex Propulsion System for Space and Air Vehicles”, *JBIS*, Vol. 57, No 11/12, 2004, pp. 379–390.
- [115] Bolonkin, A.A., (2004i), Utilization of Wind Energy at High Altitude, AIAA-2004-5705, AIAA-2004-5756, International Energy Conversion Engineering Conference at Providence., RI, Aug.16-19. 2004. USA. GOTO: <http://arxiv.org> and search “Bolonkin”.
- [116] Bolonkin, A.A., Cloutier D., (2004j). Search and Attack Strategies, AIAA Conference Guidance, Navigation, and Control, Rhode Island, 16-19 August, 2004, Tr. #20201.
- [117] Bolonkin, A., Cloutier D., (2004k). Search for Enemy Targets, *Technica. Report AFRL-MN-EG-TR-2003-1716*, June 2002. 49 p.
- [118] Bolonkin, A.A., (2004k), Twenty-first century – the beginning of human immortality, *Journal “Kybernetes”*, Vol. 33, No.9/10, 2004, pp. 1535-1542, Emerald Press, [www.emeraldinsight.com/ISSN 0368-492X.htm](http://www.emeraldinsight.com/ISSN%200368-492X.htm) (English).
- [119] Bolonkin, A.A., (2004L), Method of Recording and Saving of Human Soul for Human Immortality and Installation for It. US PTO, disclosure document #567484 of December 24, 2004.
- [120] Bolonkin, A.A., (2005a) “*High Speed Catapult Aviation*”, AIAA-2005-6221, Atmospheric Flight Mechanic Conference – 2005, 15–18 August, 2005, USA.
- [121] Bolonkin, A.A., (2005b), “*Kinetic Anti-Gravitator*”, AIAA-2005-4504, 41 Propulsion Conference, 10–12 July 2005, Tucson, Arizona, USA.
- [122] Bolonkin, A.A., (2005c), “*Electrostatic Solar Wind Propulsion System*”, AIAA-2005-3857, 41 Propulsion Conference, 10–13 July 2005, Tucson, Arizona, USA.
- [123] Bolonkin, A.A., (2005d), “*Sling Rotary Space Launcher*”, AIAA-2005-4035, 41 Propulsion Conference, 10–13 July 2005, Tucson, Arizona, USA.
- [124] Bolonkin, A.A., (2005e), “*Electrostatic Utilization Asteroids for Space Flight*”, 41 Propulsion conference, 10–12 July 2005, Tucson, Arizona, USA, AIAA-2005-3857.
- [125] Bolonkin, A.A., (2005f), “*Guided Solar Sail and Electric Generator*”, 41 Propulsion conference, 10–12 July, 2005, Tucson, Arizona, USA, AIAA-2005-3857.
- [126] Bolonkin, A.A., (2005g), “*Problems of Levitation and Artificial Gravity*”, 41 Propulsion conference, 10–12 July 2005, Tucson, Arizona, USA, AIAA-2005-3365.
- [127] Bolonkin, A.A., (2005h), “*Radioisotope Sail and Electric Generator*”, 41 Propulsion conference, 10–12 July, 2005, Tucson, Arizona, USA, AIAA-2005-3653.
- [128] Bolonkin, A.A., Murphy R., (2005i). Geometry-Based Parametric Modeling for Single Pursuer Multiple Evader Problems. *Journal JGCD*, v.28, #1, 2005
- [129] Bolonkin, A.A. (2006a), Book “*Non-Rocket Space Launch and Flight*”, Elsevier, London, 2006, 488 ps. Contents can be accessed: GOTO: <http://Bolonkin.narod.ru/p65.htm> , <http://www.scribd.com/doc/24056182> .  
Book contains more than 20 of the author’s revolutionary concepts and ideas.
- [130] Bolonkin, A.A., (2006b), *Beam Space Propulsion*, AIAA-2006-7492, Conference Space-2006, 18-21 Sept., 2006, San Jose, CA, USA. GOTO: <http://arxiv.org> and search “Bolonkin”.
- [131] Bolonkin, A.A., (2006c), *Electrostatic AB-Ramjet Space Propulsion*, AIAA/AAS Astrodynamics Specialist Conference, 21-24 August 2006, USA. AIAA-2006-6173. *Journal*

- "Aircraft Engineering and Aerospace Technology", Vol.79, #1, 2007. GOTO: <http://arxiv.org> and search "Bolonkin".
- [132] Bolonkin, A.A., (2006d), Electrostatic Linear Engine, AIAA-2006-5229, 42nd Joint Propulsion Conference, 9-12 June 2006, Sacramento, USA. *Journal "Aircraft Engineering and Aerospace Technology"*, Vol.78, #6, 2006, pp.502-508.
- [133] Bolonkin, A.A., (2006e), *High-Speed Solar Sail*, AIAA-2006-4806, 42nd Joint Propulsion Conference, 9-12 June 2006, Sacramento, USA. GOTO: <http://arxiv.org> and search "Bolonkin".
- [134] Bolonkin, A.A., (2006f), *A New Method of Atmospheric Reentry for Space Shuttle*, AIAA-2006-6985, MAO Conference, 6-9 Sept. 2006, USA. GOTO: <http://arxiv.org> and search "Bolonkin".
- [135] Bolonkin, A.A., (2006g), *Suspended Air Surveillance System*, AIAA-2006-6511, AFM Conference, 21-29 Aug. 2006, Keystone, USA. <http://arxiv.org>, search "Bolonkin".
- [136] Bolonkin, A.A., (2006h), Optimal Solid Space Tower, AIAA-2006-7717. ATIO Conference, 25-27 Sept. 2006, Wichita, Kansas, USA. <http://arxiv.org>, search "Bolonkin".
- [137] Bolonkin, A.A., (2006i), *Theory of Space Magnetic Sail Some Common Mistakes and Electrostatic MagSail*. Presented as paper AIAA-2006-8148 to 14-th Space Planes and Hypersonic System Conference, 6-9 November 2006, Australia. <http://arxiv.org>, search "Bolonkin".
- [138] Bolonkin, A.A., (2006j) *Micro -Thermonuclear AB-Reactors for Aerospace*. Presented as paper AIAA-2006-8104 in 14th Space Plane and Hypersonic Systems Conference, 6-8 November, 2006, USA. <http://arxiv.org>, search "Bolonkin".
- [139] Bolonkin, A.A., Cathcart, R.B., (2006k). *A Low-Cost Natural Gas/Freshwater Aerial Pipeline*. GOTO: <http://arxiv.org> and search "physics/0701061".
- [140] Bolonkin, A.A., (2006l) *Cheap Textile Dam Protection of Seaport Cities against Hurricane Storm Surge Waves, Tsunamis, and Other Weather-Related Floods*. <http://arxiv.org>, search "Bolonkin".
- [141] Bolonkin, A., Cathcart R.B., (2006m). *The Java-Sumatra Aerial Mega-Tramway*. GOTO: <http://arxiv.org> and search "physics/0701099".
- [142] Bolonkin, A., Cathcart R.B., (2006n). *Inflatable Evergreen Polar Zone Dome (EPZD) Settlements*. GOTO: <http://arxiv.org> and search "physics/0701098".
- [143] Bolonkin, A.A. and R.B. Cathcart, (2006) "A Cable Space Transportation System at the Earth's Poles to Support Exploitation of the Moon", *Journal of the British Interplanetary Society* 59: 375-380.
- [144] Bolonkin, A.A., (2006o). *Control of Regional and Global Weather*. <http://arxiv.org>, search "Bolonkin".
- [145] Bolonkin, A.A., Cathcart R.B., (2006p). *Antarctica: A Southern Hemisphere Windpower Station?* GOTO: <http://arxiv.org> and search "physics/0701055".
- [146] Bolonkin, A.A., (2006q). *AB Levitator and Electricity Storage*. <http://arxiv.org>, search "Bolonkin", AIAA-2007-4612.
- [147] Bolonkin, A.A. (2006r). *Simplest AB-Thermonuclear Space Propulsion and Electric Generator*. <http://arxiv.org>, search "Bolonkin".



- [148] Bolonkin, A.A., (2006s). *Wireless Transfer of Electricity in Outer Space*. <http://arxiv.org>, search "Bolonkin".
- [149] Bolonkin, A.A., (2006t). *Electrostatic AB-Ramjet space propulsion for interplanetary flight, AEAT*, vol. 79, No. 1, 2007, pp. 3 - 16.
- [150] Bolonkin A.A., (2006u). *Method of Recording and Saving of Human Soul for Human Immortality and Installation for it*. Patent application US PTO 11613380 of 12/20/06.
- [151] Bolonkin, A.A. and R.B. Cathcart (2006v), "Inflatable 'Evergreen' dome settlements for Earth's Polar Regions", *Clean Technologies and Environmental Policy* DOI 10.1007/s10098-006-0073-4.
- [152] Bolonkin, A.A., (2006w). New AB-Thermonuclear Reactor for Aerospace, AIAA-2006-7225, <http://arxiv.org>. Search: "Bolonkin".
- [153] Cathcart, R.B. and Bolonkin, A.A., (2006x), The Golden Gate Textile Barrier: Preserving California Bay of San Francisco from a Rising North Pacific Ocean. GOTO: <http://arxiv.org> and search "physics/0702030".
- [154] Cathcart, R.B and Bolonkin A.A., (2006y), Ocean Terracing. GOTO: <http://arxiv.org> and search "physics/0701100".
- [155] Bolonkin, A.A., (2006z). Method of recording and saving of human soul for human Immortality and Installation for it. Patent application #11/613,380 of 12/20/06. USPTO.
- [156] Book (2006z2), *Macro-Engineering - A challenge for the future*. Collection of articles. Eds. V. Badescu, R.B. Cathcart and R.D. Schuiling, Springer, 2006. (Collection contains two of A.A. Bolonkin's articles: Space Towers; Cable Anti-Gravitator, Electrostatic Levitation and Artificial Gravity).
- [157] Bolonkin, A.A., (2007a). AB Levitrons and their Applications to Earth's Motionless Satellites, <http://arxiv.ru>, search: Bolonkin. AIAA Joint Propulsion Conference, Paper AIAA-2008-8150, 21-23 July, Hartford, Connecticut, USA.
- [158] Bolonkin A.A., (2007b). Passenger life-saving in a badly damaged aircraft scenario, AIAA-2007-5844, <http://arxiv.ru>, search: Bolonkin.
- [159] Bolonkin, A.A., (2007c). Optimal Electrostatic Space Tower (Mast, New Space Elevator), AIAA-2007-6201, <http://arxiv.ru>, search: Bolonkin.
- [160] . Bolonkin, A.A., (2007d). Electrostatic Space Climber, AIAA-2007-5838, 43-rd Joint Propulsion Conference, Cincinnati, Ohio, USA, 9-11 July, 2007. <http://arxiv.ru>, search: Bolonkin.
- [161] Bolonkin, A.A., (2007e). Inflatable Dome for Moon, Mars, Asteroids and Satellites, AIAA-2007-6262, <http://arxiv.ru>, search: Bolonkin.
- [162] Bolonkin, A.A., (2007f). *Human Immortality and Electronic Civilization*, 3-rd Edition, Lulu, 2007, 66 pgs., (English and Russian), <http://www.lulu.com> search "Bolonkin".
- [163] Bolonkin, A.A., (2007g). *Memories of Soviet Political Prisoner*, Lulu, 2007, 66 pgs., (English and Russian), <http://www.lulu.com> search "Bolonkin". English is translated from same Russian book, New York, 1991. <http://www.scribd.com/doc/24053855>
- [164] Bolonkin, A.A., (2007h). *Extraction Water and Energy from Atmosphere*. <http://arxiv.org>. Search: "Bolonkin".
- [165] Bolonkin A.A., (2007j). AB Method of Irrigation without Water (Closed-loop water cycle). <http://arxiv.org>, search term: "Bolonkin".

- [166] Bolonkin A.A., (2007k). Thermonuclear Reflect AB-Reactor, <http://arxiv.org>, search term: "Bolonkin".
- [167] Bolonkin A.A., (2007-l). AB-Ferromagnetic Space Propulsion. <http://arxiv.org>, search term: "Bolonkin". AIAA Joint Propulsion Conference, Paper AIAA-2008-5151, 21-23 July, Hartford, Connecticut, USA.
- [168] Bolonkin, A.A., (2008a). Floating Cities, Islands, States. <http://arxiv.org>, search term: "Bolonkin".
- [169] Bolonkin, A.A., (2008b). AB-Tubes and Quasi-Superconductivity at Room Temperature, <http://arxiv.org>, search term: "Bolonkin".
- [170] Bolonkin, A.A., Krinker M., (2008c). Magnetic Aircraft, <http://arxiv.org>, search term: "Bolonkin". AIAA Joint Propulsion Conference, Paper AIAA-2008-4610, 21-23 July, Hartford, Connecticut, USA.
- [171] Calasso, F.E., (1989), *Advanced Fibers and Composite*, Gordon and Branch Scientific Publisher, New York, 1989.
- [172] *Carbon and High Performance Fibers*, (1995), Directory, NY 1995, Chapman and Hall, 6th ed., New York.
- [173] *Concise Encyclopedia of Polymer Science and Engineering*, (1990), Ed. J. I. Kroschwitz, 1990. New York.
- [174] Clarke, A.C.: *Fountains of Paradise*, Harcourt Brace Jovanovich, New York, 1978.
- [175] Dresselhaus, M.S., (2000), *Carbon Nanotubes*, Springer, New York, 2001.
- [176] Fedorov, V.D., (1981), *Basis of Rocket Flight*, Moscow, Nauka.(Russian).
- [177] *Handbook of Physical Quantities*, Ed. Igor S. Grigoriev, 1997, CRC Press, USA.
- [178] Harris, J.T. (1973), *Advanced Material and Assembly Methods for Inflatable Structures*. AIAA, Paper No. 73-448.
- [179] Johnson, A., *Space Research: Organizing for Economical Efficiency*. Presented as paper AIAA-2006-7224 in Conference "Space-2006", 19-21 September 2006, San Diego, California, USA.
- [180] Johnson, A., Space research: problems of efficiency. *Journal "Actual Problems of Aviation and Aerospace System"*, No.1, 2007.  
[http://www.kcn.ru/tat\\_en/science/ans/journals/rasj\\_cnt/07\\_1\\_10.html](http://www.kcn.ru/tat_en/science/ans/journals/rasj_cnt/07_1_10.html)
- [181] Kikoin, I.K., (1976), *Table of Physical Magnitudes*, Moscow, Atomic Publish House. (Russian).
- [182] Landis, G.A., (2004), Interstellar Flight by Particle Beam, *Acta Astronautica*, Vol. 55, pp.931 - 934.
- [183] Landis, G., (2000). "Dielectric Films for Solar- and Laser-pushed Lightsails," *AIP Conference Proceedings Volume 504*, pp. 989-992; Space Technology and Applications International Forum (STAIF-2000), Jan. 30 - Feb. 3, Albuquerque NM.
- [184] Landis, Geoffrey A., Cafarelli Craig, (1999). The Tsiolkovski Tower Re-Examined, *JBIS*, Vol. 32, pp. 176 -180, 1999.
- [185] Landis, Geoffrey A. and Cafarelli, Craig, (1995), "The Tsiolkovski Tower," paper IAF-95-V.4.07, 46th International Astronautics Federation Congress, Oslo Norway, 2-6 Oct. 1995.

- There is also an errata to this paper, which was published in JBIS: Landis, Geoffrey A., (2005), "Correction," *Journal of the British Interplanetary Society*, Vol. 58, p. 58.
- [186] Landis, Geoffrey A., (1998), "*Compression Structures for Earth Launch*," paper AIAA-98-3737, 24th AIAA/ASME/SAE/ASEE Joint Propulsion Conf., July 13-15, Cleveland OH.
- [187] Nishikawa, K., Wakatani, M., *Plasma Physics*, Spring, 2000.
- [188] Omidi, N. and Karimabadi, H., (2003), "*Electrostatic Plasma Sail*", AIAA 2003-5227, 2003. 39th AIAA/ASME/SAE/ASEE Joint Propulsion Conference and Exhibit 20-23 July 2003, Huntsville, Alabama. Contains a principal scientific mistakes.
- [189] Regan, F.J., Anandakrishnan S.M., *Dynamics of Atmospheric Re-Entry*, AIAA, 1993
- [190] Shortley, G., Williams D., *Elements of Physics*, Prentice-Hall, Inc., Englewood Cliffs, New Jersey, 1971, USA.
- [191] Smitherman, D.V., Jr., *Space Elevators*, NASA/CP-2000-210429, 2000.
- [192] Tsiolkovski, K.E.: "Speculations about Earth and Sky on Vesta," Moscow, Izd-vo AN SSSR, 1959; Grezi o zemle i nebe (in Russian), Academy of Sciences, U.S.S.R., Moscow, p.35, 1999.

#### Works in Russian Language

- [193] Tsiolkovski, K.E. (1959), "*Speculations about Earth and Sky on Vesta*", Moscow, Izd-vo AN SSSR, 1959; Grezi o zemle i nebe, Academy of Sciences, USSR, Moscow, p. 35, 1999.
- [194] Mayboroda, A., Zero Gravity on Earth, "*Yuniy Tehnik*" ("Young Technician"), No. 10, October 1988, Moscow.
- [195] Pokrovskii, G.I., (1964), *Space Tower*, TM, ("Technology for Youth"), No. 10.
- [196] Poliakov, G., (1977), *Space Necklace of Earth*, TM, ("Technology for Youth"), No. 4.
- [197] Yunitskii A., (1982), "*General Planetary Transport System*", "TM" ("Technology for Youth"), No. 6.) (in Russian). (see last four Russian works in: <http://www.ipu.ru/stran/bod/ing/sovet2.htm>, Pictures: [http://www.ipu.ru/stran/bod/ing/sovet\\_ris.htm](http://www.ipu.ru/stran/bod/ing/sovet_ris.htm))

#### NIAC Reports in USA

- [198] <http://auditing-science.narod.ru> or <http://www.geocities.com/auditing.science/>
- [199] Christensen C., "Ultralight Solar Sail for Interstellar Travel", <http://NASA-NIAC.narod.ru>
- [200] Hose, S. D., "Antimatter Drive Sail for Deep Space Missions", <http://NASA-NIAC.narod.ru>
- [201] Landis, G. A., "Advanced Solar and Laser Pushed Lightsail Concepts", <http://NASA-NIAC.narod.ru>
- [202] Miller, D. W., "Electromagnetic Formation Flight", <http://NASA-NIAC.narod.ru>
- [203] Zubrin, R., "The Magnetic Sail". <http://NASA-NIAC.narod.ru> .
- [204] About NIAC: GO TO: <http://auditing-science.narod.ru> or <http://www.geocities.com/auditing.science/>, <http://NASA-NIAC.narod.ru>

### Some of A.A. Bolonkin's Popular Publications

- [205] Personal site: GOTO: <http://Bolonkin.narod.ru> .
- [206] Bibliography (about the author discussing his ideas) publication in Russian press and Internet in 1994 - 2004 (<http://www.km.ru>, <http://pravda.ru>, <http://n-t.ru>, ets. Search: Bolonkin)/
- [207] Bolonkin, A.A., Our children may be a last people generation, *Literary newspaper*, 10/11/95, #41 (5572), Moscow, Russia (Russian).
- [208] Bolonkin, A.A., Stop the Earth. I step off. *People Newspaper*, Sept., 1995. Minsk, Belorussia (Russian).
- [209] Bolonkin, A.A., End of Humanity, but not End of World. *New Russian Word*, 3/6/96, p.14, New York, USA (Russian).
- [210] Bolonkin, A.A., *Natural Human Purpose is to be God*. <http://Bolonkin.narod.ru> (Russian).
- [211] Bolonkin, A.A., *American and Russian Science*.(English). <http://Bolonkin.narod.ru>.
- [212] Bolonkin, A.A., Locate the God into Computer-Internet Network (in Russian).  
<http://Bolonkin.narod.ru> .
- [213] Blekherman, A., *Short biography of Dr. A. Bolonkin*. (English, Russian)  
<http://Bolonkin.narod.ru>
- [214] Dr. Sci. M. Krinker, World Space Congress-2002 (about 9 Bolonkin's scientific works presented to Congress). <http://Bolonkin.narod.ru> (Russian).
- [215] Ruduyk, B., New ideas of Dr. Bolonkin, *Newspaper "Fact"*, Ukraine (in Ukraine).  
<http://Bolonkin.narod.ru> .
- [216] Kurolenko, N., Electronic Society, *News paper "Kievskie Vedomosti"*, C. Kiev, Ukraine, 27 May, 2002. <http://Bolonkin.narod.ru> .
- [217] Bay, E., Our soul is only set our knowledge (about ideas of A. Bolonkin). *Newspaper "Literary Newspaper"*. 10 July, 2002. Moscow (in Russian).
- [218] Golovkov, A., Time for thinking, Magazine "*Ogonek*", 1988, Moscow, Russia (in Russian). <http://Bolonkin.narod.ru> .
- [219] Levin, V., "*Take-off and Landing*" (article from magazine "*Vestnik*" about Bolonkin. 1992)(Russian).
- [220] Bolonkin, A.A., Peculiarities of Soviet and American Sciences. (Russian).  
<http://Bolonkin.narod.ru>
- [221] Bolonkin, A.A., Memoirs of Soviet Political Prisoner (English). <http://www.lulu.com> search "Bolonkin", <http://Bolonkin.narod.ru> .
- [222] Getmanskii Igor, Price of Immortality, Moscow, EKCMO, 2003, 480 ps., (Fantasy, in Russian).  
*Reader finds some last author's articles in <http://www.scribd.com> (23); <http://arxiv.org> , (45); <http://www.archive.org/> (20) and <http://aiaa.org> (41) search "Bolonkin" . 20 June, 2011.*

Some books (2007-2011) and articles by A.Bolonkin on line in <http://www.scribd.com> and <http://www.archive.org> published in 2010-2011:

**Books:**

- 1) Бессмертие людей и электронная цивилизация (in Russian). 3-е издание, 2007  
<http://www.scribd.com/doc/24052811> ,  
<http://www.archive.org/details/HumanImmortalityAndElectronicCivilizationInEussian>
- 2) Human Immortality and Electronic Civilization. 3<sup>rd</sup> edition (in English), 2007.  
<http://www.scribd.com/doc/24053302> ,  
<http://www.archive.org/details/HumanImmortalityAndElectronicCivilization>
- 3) Записки советского политзаключенного. 1991 (in Russian). 70 стр.  
<http://www.scribd.com/doc/24053537>  
<http://www.archive.org/details/MemoirsOfSovietPoliticalPrisonerinRussian>
- 4) Memories of Soviet Political Prisoner. Translation from Russian. Lulu, 1995.  
<http://www.scribd.com/doc/24053855>  
<http://www.archive.org/details/MemoirsOfSovietPoliticalPrisoner>
- 5) “Non Rocket Space Launch and Flight”. Elsevier, 2005. 488 pgs.  
<http://www.archive.org/details/Non-rocketSpaceLaunchAndFlight> ,  
<http://www.scribd.com/doc/24056182> .
- 6) “New Concepts, Ideas, Innovations in Aerospace, Technology and the Human Sciences”, NOVA, 2006, 510 pgs. <http://www.scribd.com/doc/24057071> ,  
<http://www.archive.org/details/NewConceptsIfeasAndInnovationsInAerospaceTechnologyAndHumanSciences>
- 7) “Macro-Projects: Environments and Technologies”, NOVA, 2007, 536 pgs.  
<http://www.scribd.com/doc/24057930> .  
<http://www.archive.org/details/Macro-projectsEnvironmentsAndTechnologies>
- 8) “New Technologies and Revolutionary Projects”, Scribd, 2008, 324 pgs,  
<http://www.scribd.com/doc/32744477> ,  
<http://www.archive.org/details/NewTechnologiesAndRevolutionaryProjects>,
- 9) «Жизнь. Наука. Будущее» (биографические очерки, исследования и инновации), Scribd, 2010, 286 pgs, 23 Mb. <http://www.scribd.com/doc/45901785> , or  
<http://www.archive.org/details/Life.science.futureinRussian...>
- 10) LIFE. SCIENCE. FUTURE (Biography notes, researches and innovations). Scribd, 2010, 208 pgs. 16 Mb.  
<http://www.scribd.com/doc/48229884>,  
<http://www.archive.org/details/Life.Science.Future.biographyNotesResearchesAndInnovations> or  
<http://www.lulu.com> ,  
[http://www.publishamerica.net/sc/productsearch.cgi?search\\_field=Bolonkin&storeid=\\*1ed736148e14b9de8c3184b7f08fb4a634](http://www.publishamerica.net/sc/productsearch.cgi?search_field=Bolonkin&storeid=*1ed736148e14b9de8c3184b7f08fb4a634) , or [http://www.amazon.com/s/ref=nb\\_sb\\_noss?url=search-alias%3Dstripbooks&field-keywords=Bolonkin&x=12&y=19](http://www.amazon.com/s/ref=nb_sb_noss?url=search-alias%3Dstripbooks&field-keywords=Bolonkin&x=12&y=19) .
- 11) Universe, Human Immortality and Future Human Evaluation. Scribd. 2010г., 4.8 Mb.  
<http://www.archive.org/details/UniverseHumanImmortalityAndFutureHumanEvaluation>,  
<http://www.scribd.com/doc/52969933/> .
- 12) Human immortality and electronic civilization, Publish America, Baltimore, USA, 2010, 140 ps. ISBN: 978-1-4489-3969-5, 140 pages, 5.5 x 8.5, \$9.95.  
[http://www.publishamerica.net/sc/productsearch.cgi?search\\_field=Bolonkin&storeid=\\*1ed736148e14b9de8c3184b7f08fb4a634](http://www.publishamerica.net/sc/productsearch.cgi?search_field=Bolonkin&storeid=*1ed736148e14b9de8c3184b7f08fb4a634) or [http://www.amazon.com/s/ref=nb\\_sb\\_noss?url=search-alias%3Dstripbooks&field-keywords=Bolonkin&x=12&y=19](http://www.amazon.com/s/ref=nb_sb_noss?url=search-alias%3Dstripbooks&field-keywords=Bolonkin&x=12&y=19) .
- 13) Memoirs of Soviet Political Prisoner, Publish America, Baltimore, USA, 2010, 108 ps. ISBN: 978-1-4489-4414-9, 108 Pages, 5.5 x 8.5, \$9.95.  
[http://www.publishamerica.net/sc/productsearch.cgi?search\\_field=Bolonkin&storeid=\\*1ed736148e14b9de8c3184b7f08fb4a634](http://www.publishamerica.net/sc/productsearch.cgi?search_field=Bolonkin&storeid=*1ed736148e14b9de8c3184b7f08fb4a634)

14) LIFE. SCIENCE. FUTURE (Biography notes, researches and innovations). Publish America, Baltimore, USA, 2010, 208 pgs. 16 Mb. ISBN: 978-1-4512-7983-2, 306 Pages, 6x9, \$15.95.

<http://www.lulu.com> search "Bolonkin" or

[http://www.publishamerica.net/sc/productsearch.cgi?search\\_field=Bolonkin&storeid=\\*1ed736148e14b9de8c3184b7f08fb4a634](http://www.publishamerica.net/sc/productsearch.cgi?search_field=Bolonkin&storeid=*1ed736148e14b9de8c3184b7f08fb4a634) or [http://www.amazon.com/s/ref=nb\\_sb\\_noss?url=search-alias%3Dstripbooks&field-keywords=Bolonkin&x=12&y=19](http://www.amazon.com/s/ref=nb_sb_noss?url=search-alias%3Dstripbooks&field-keywords=Bolonkin&x=12&y=19) .

### Articles (2009-2011):

- 1) Femtotechnology: Nuclear AB-Material with Fantastic Properties.  
<http://www.scribd.com/doc/24046679/> , American Journal of Engineering and Applied Science, Vol. 2, #2, 2009, pp.501-514.
- 2) Femtotechnology: Design of the Strongest AB-Matter for Aerospace  
Journal of Aerospace Engineering, Oct. 2010, Vol. 23, No. 4, pp.281-292.  
<http://www.archive.org/details/FemtotechnologyDesignOfTheStrongestAb-matterForAerospace>  
<http://www.scribd.com/doc/57369206/Femtotechnology-Design-of-the-Strongest-AB-Matter-for-Aerospace>
- 3) Converting of Any Matter to Nuclear Energy by-AB-Generator  
American Journal of Engineering and Applied Science, Vol. 2, #4, 2009, pp.683-693.  
<http://www.scribd.com/doc/24048466/>
- 4) Converting of any Matter to Nuclear Energy by AB-Generator and Aerospace  
<http://www.archive.org/details/ConvertingOfAnyMatterToNuclearEnergyByAb-generatorAndAerospace>  
<http://www.scribd.com/doc/57419950/Converting-of-Matter-to-Nuclear-Energy-by-AB-Generator-and-its-Application>
- 4a) Превращение материи в ядерную энергию АБ-генератором и фотонные ракеты  
(популярное изложение научной статьи) . <http://www.scribd.com/doc/45901918/>
- 4b) RailGun Space Launcher, Journal of Aerospace Engineering, Oct. 2010, Vol. 23, No. 4, pp.293-299.
- 5) Artificial Explosion of Sun. AB-Criterion for Sun Detonation. Journal "Scientific Israel-Technological Advantages", Israel, Vol.13, #1, 2011, pp.45-64.  
[http://sita-journal.com/files/2\\_Cur.Iss\\_no.1.pdf](http://sita-journal.com/files/2_Cur.Iss_no.1.pdf)  
<http://www.scribd.com/doc/24541542/> ,  
<http://www.archive.org/details/ArtificialExplosionOfSun.Ab-criterionForSolarDetonation>
- 6) Blanket for Cities. Journal of Environmental Protection , Volume 02, Number 04 (June 2011). PP.327-341, Pub. Date: 2011-06-17, <http://www.scribd.com/doc/24050198> ,  
<http://www.archive.org/details/DomeShieldAMethodToContainRadioactiveDustFromDamagedNuclearStations>
- 7) Man in Outer Space without a Special Space Suit.  
American Journal of Engineering and Applied Science 2(4), 573-579, 2009, ISSN 1991-7020.  
<http://www.scribd.com/doc/24050793/>,  
<http://www.archive.org/details/LiveOfHumanityInOuterSpaceWithoutSpaceSuite>
- 8) Aerial-High-Altitude-Gas-Pipeline. *The Open Petroleum Engineering Journal*, 2009, 2, 24-35. <http://www.benthamsience.com/open/topej/articles/V002/24TOPEJ.pdf> ,  
<http://www.scribd.com/doc/24051138/> ,  
<http://www.archive.org/details/AerialAltitudeGasPipeline>
- 9) "Magnetic Space Launcher" has been published online 15 December 2010, in the ASCE, Journal of Aerospace Engineering (Vol.24, No.1, 2011, pp.124-134). <http://www.scribd.com/doc/24051286/>
- 10) An Innovative Solar Desalination System. <http://www.scribd.com/doc/24051638/>
- 11) Economically Efficient Inflatable 3-km Tower for Communication  
<http://www.scribd.com/doc/24051794/>



- 12) Production-of-Fresh-Water-by-Exhaust-Gas-of-Electric-and-Industrial-Plants. Journal "Scientific Israel-Technological Advantages". Vol.13, #1, 2011, pp.65-71. <http://www.scribd.com/doc/24052023/>
- 13) Sea-Extractor-of-Freshwater. <http://www.scribd.com/doc/24052153/>
- 14) AB-Wind-Wall. Journal "Scientific Israel-Technological Advantages", Vol.12, #4, 2010. <http://www.scribd.com/doc/24052321/>
- 15) High-Altitude-Long-Distance-Cheap-Aerial-Antenna. <http://www.scribd.com/doc/24052420/>
- 16) **Suppression-of-Forest-Fire-by-Helicopter-without-Water** <http://www.scribd.com/doc/24052503/> , <http://www.archive.org/details/SuppressionOfForestFireByHelicopterWithoutWater>
- 17) Использование Энергии Ветра Больших Высот.<http://www.scribd.com/doc/24058357>, <http://www.archive.org/details/UsingOfHighAltitudeWindEnergy>
- 17a) Utilization of Wind Energy ay High Altitude. Journal "Smart Grid and Renewable Energy", 2011,#2, pp.75-85. <http://www.scirp/journal/sqgre/> .
- 18) "Magnetic Suspended AB-Structures and Motionless Space Stations," has been published online 15 December 2010, in the ASCE, **Journal of Aerospace Engineering**(Vol.24,No.1,2011,pp.102-111), <http://www.scribd.com/doc/25883886/> .
- 19) Природная цель Человечества – стать Богом. <http://www.scribd.com/doc/26753118>
- 20) Natural Purpose of Mankind is to become a God. <http://www.scribd.com/doc/26833526>
- 21) Magnetic Space AB-Accelerator. <http://www.scribd.com/doc/26885058>
- 22) Lower Current and Plasma Magnetic Railguns. <http://www.scribd.com/doc/31090728>
- 23) Krinker M., Review of Space Towers. <http://www.scribd.com/doc/26270139>, <http://arxiv.org/ftp/arxiv/papers/1002/1002.2405.pdf>
- 24) Новые идеи в технологии, технике и оружии <http://www.scribd.com/doc/27785947/>,
- 25) Превращение материи в ядерную энергию АБ-генератором и фотонные ракеты (популярное изложение научной статьи). <http://www.scribd.com/doc/45901918/>, <http://www.archive.org/details/ConvertingOfMatterInMuclerEnergy>.
- 26) Wireless Transfer of Electricity from Continent to Continent. International Journal of Sustainable Engineering. 2011. Vol.4, #4, p. 290-300. <http://www.scribd.com/doc/42721638/>, <http://www.archive.org/details/WirelessTransferOfElectricityFromContinentToContinent>
- 27) Robot as Person. Personhood. Three Prerequisites or Laws of Robots. <http://www.scribd.com/doc/57532296/Robot-as-Person-Personhood-Three-Prerequisites-or-Laws-of-Robots> , <http://www.archive.org/details/RobotAsPersonpersonhood.ThreePrerequisitesOrLawsOfRobots>
- 28) Review of new ideas, innovations of non-rocket propulsion systems for Space Launch and Flight (Part 1). <http://www.scribd.com/doc/54655572/> , <http://www.archive.org/details/ReviewOfNewIdeasInnovationOfNon-rocketPropulsionSystemsForSpace>
- 29) Review of new ideas, innovations of non-rocket propulsion systems for Space Launch and Flight (Part 2). <http://www.scribd.com/doc/54656166/> , <http://www.archive.org/details/Review2OfNewIdeasInnovationsOfNon-rocketPropulsionSystemsForSpace>
- 30) Review of new ideas, innovations of non-rocket propulsion systems for Space Launch and Flight (Part 3). <http://www.scribd.com/doc/54656800/> <http://www.archive.org/details/Review3OfNewIdeasInnovationsOfNon-rocketPropulsionSystemsForSpace>



- 31) Femtotechnology: AB-Needles. Fantastic properties and Applications. Scribd, 2010,  
<http://www.scribd.com/doc/55054819/> , <http://vixra.org/abs/1111.0064>  
<http://www.archive.org/details/FemtotechnologyAb-needles.FantasticPropertiesAndApplications>  
 Published in collection: Propulsion: Types, Technology and Applications. NOVA. 2011.  
[https://www.novapublishers.com/catalog/product\\_info.php?products\\_id=24848](https://www.novapublishers.com/catalog/product_info.php?products_id=24848)
- 32) **АБ-материя и иглы. Потрясающие свойства и применение (популярное изложение научной статьи).**  
[http://www.pravda.ru/science/eureka/hypotheses/23-05-2011/1077601-nuclon\\_materia-0/](http://www.pravda.ru/science/eureka/hypotheses/23-05-2011/1077601-nuclon_materia-0/)  
<http://www.archive.org/details/Ab-matterAndAb-needles.FantasticProperties.->
- 33) Space Wing Electro Relativistic AB-Ship.  
 Collection: **Interstellar Medium: New Research. NOVA, 2011.**  
[https://www.novapublishers.com/catalog/product\\_info.php?products\\_id=22357](https://www.novapublishers.com/catalog/product_info.php?products_id=22357)  
<http://www.scribd.com/doc/56874853/Space-Wing-Electro-Relativistic-AB-Ship>  
<http://www.archive.org/details/SpaceWingElectroRelativisticAb-ship>
- 34) **"Floating Cities on Ice Platform"** published on **"The Open Ocean Engineering Journal"**. Vol. 3, 2010, pp. 1-11. <http://www.benthamscience.com/open/tooej/articles/V003/1TOOEJ.pdf> .
- 35) Production of Freshwater and Energy from Earth's Atmosphere. Journal "Smart Grid and Renewable Energy", 2011,#2, pp.86-98. <http://www.scirp/journal/sqgre/> .
- 36) Man in Outer Space without a Special Space Suit.  
 American J. of Engineering and Applied Sciences 2 (4): 573-579, 2009, ISSN 1941-7020.  
<http://www.scribd.com/doc/24050793>
- 37) **"Air transfer of mechanical energy"**, International Journal "Actual problems of aviation and aerospace systems: processes, models, experiment" (No.1(19), v.10, 2005, 102-110).
- 38) **SUPPRESSION OF FOREST FIRE BY HELICOPTER WITHOUT WATER**  
*Journal "Scientific Israel- Technological Advantages"* , Vol.12, 4, 2010
- 39) **Bolonkin A.A.**, Man in Outer Space without a Special Space Suit  
 American J. of Engineering and Applied Sciences 2 (4): 573-579, 2009  
<http://www.scipub.org/fulltext/ajeas/ajeas24573-579.pdf> (?)
- 40) **Alexander Bolonkin**, **"Transparent Inflatable Column Film Dome for Nuclear Stations, Stadiums, and Cities,"** **Science and Technology of Nuclear Installations**, vol. 2011, Article ID 175492, 13 pages, 2011.  
 doi:10.1155/2011/175492.  
<http://www.hindawi.com/journals/stni/2011/175492/>

### Some Collections having my articles:

- 35) **Macro-engineering Seawater in Unique Environments. Springer. 2010.**  
<http://www.springer.com/environment/aquatic+sciences/book/978-3-642-14778-4>
- 1) **The Bering Strait Seawater Deflector (BSSD): Arctic Tundra Preservation Using an Immersed, Scalable and Removable Fiberglass Curtain.** . . . . . 741  
 Richard B. Cathcart, Alexander A. Bolonkin and Radu D. Rugescu
- 2) **A Novel Macro-Engineering Approach to Seawater Desalination** . . . . 675  
 Alexander A. Bolonkin, Shmuel Neumann and Joseph J. Friedlander
- 3) **Macro-Engineering Lake Eyre with Imported Seawater** . . . . . 553  
 Viorel Badescu, Richard B. Cathcart, Marius Paulescu, Paul Gravila and Alexander A. Bolonkin
- 36) **Handbook on Solar Wind: Effects, Dynamics and Interactions. NOVA. 2009.**

[https://www.novapublishers.com/catalog/product\\_info.php?products\\_id=8903](https://www.novapublishers.com/catalog/product_info.php?products_id=8903)

- 1) Electrostatic Solar Light - Wind Sail, pp. 353-365 (Alexander Bolonkin, C & R, Brooklyn, NY)
- 2) AB - Solar and Solar Wind Sail, pp. 367-378. (Alexander Bolonkin, C & R, Brooklyn, NY).
- 3) Electrostatic Magsail.p. 379-389 . (Alexander Bolonkin, C & R, Brooklyn, NY).

**37) Interstellar Medium: New Research. NOVA, 2011.**

[https://www.novapublishers.com/catalog/product\\_info.php?products\\_id=22357](https://www.novapublishers.com/catalog/product_info.php?products_id=22357)

- 1) Space Wing Electro AB-Ship. (Alexander Bolonkin, C&R, Brooklyn, New York, USA).

**38) Propulsion: Types, Technology and Applications. NOVA. 2011.**

[https://www.novapublishers.com/catalog/product\\_info.php?products\\_id=24848](https://www.novapublishers.com/catalog/product_info.php?products_id=24848)

- 1) Review of New Ideas, Innovation of Non-Rocket Propulsion Systems for Space Launch and Flight - (Part 1) . (Alexander Bolonkin, C&R, Brooklyn, New York, USA)
- 2) Review of New Ideas, Innovations of Non-Rocket Propulsion Systems for Space Launch and Flight - (Part 2) . (Alexander Bolonkin, C&R, NJIT, Brooklyn, New York, USA)
- 3) Review of New Ideas, Innovations of Non-Rocket Propulsion Systems for Space Launch and Flight - (Part 3) . (Alexander Bolonkin, C&R, NJIT, Brooklyn, New York, USA)
- 4) Superconductivity Space Accelerator . (Alexander Bolonkin, C&R, Brooklyn, New York, USA)
- 5) Femtotechnology: AB-Needles - Fantastic Properties and Applications in Propulsion System and Aerospace . (A.A. Bolonkin, C&R, Brooklyn New York, USA)
- 6) Lower Current and Plasma Magnetic RailGun . (A. Bolonkin, C&R, Brooklyn, New York, USA)

**38) Mars.** Springer. 2009.

- Ch.10. New Solutions for Nuclear Energy and Flights on Mars, pp.287-330.  
Ch.23. Artificial Environments on Mars. Pp.599-628.

**39) Macro-Engineering.** A Challenge for the Future. Springer. 2006.

- 1) Space Towers. Pp.121-150.
- 2) Cable Anti-Gravitator. Electrostatic Levitation and Artificial Gravity. Pp.175-214.

**40) ARTIFICIAL EXPLOSION OF SUN AND AB-CRITERION FOR SOLAR DETONATION,**  
Journal "Scientific Israel-Technological Advantages", Israel,  
Vol.13, #1, 2011, pp.45-64. [http://sita-journal.com/files/2\\_Cur.Iss\\_no.1.pdf](http://sita-journal.com/files/2_Cur.Iss_no.1.pdf)

**41) Bolonkin A.A.,** Production water by exhaust gas of electric and heat plants.  
Journal "Scientific Israel-Technological Advantages". Vol.13, #1, 2011, pp.65-71.

**42) Bolonkin A.A.,** A Cheap Inflatable High Altitude Gas Pipeline. *The Open Petroleum Engineering Journal*,  
2009, 2, 24-35. <http://www.benthamsience.com/open/topej/articles/V002/24TOPEJ.pdf>

**43) Alexander A. Bolonkin,** Aerial high altitude gas pipeline.  
Journal of Natural Gas Science and Engineering (July 2010), 2 (2-3), pg. 114-121

**44) Bolonkin A.A.,** SUPPRESSION OF FOREST FIRE BY HELICOPTER WITHOUT WATER  
Journal "Scientific Israel-Technological Advantages" (SITA), Vol.12, 4, 2010

45) [Protection of Environment from Damaged Nuclear Station and Transparent Inflatable Blanket for Cities—Protection from Radioactive Dust and Chemical, Biological Weapons](#)

Alexander Bolonkin, Journal of Environmental Protection , Volume 02, Number 04 (June 2011). PP.327-341, Pub. Date: 2011-06-17,  
[Abstract](#) | [References](#) Full Paper: [PDF](#) (Size:2150KB), PP.327-341,  
 Pub. Date: 2011-06-17, Downloads: 322  
 DOI: 10.4236/jep.2011.24037

---

List of some last publications by Bolonkin:

<http://www.archive.org/details/ListOfSomeLastScientificPublicationsByAlexanderBolonkin>  
<http://www.scribd.com/doc/63456356/>

Arxiv my articles corr 5 29 10

**Article (45) by A.Bolonkin in <http://arxiv.org> (2004-2007)**

1. Magnetic Space Launcher. 2007. Abstract <http://arxiv.org/abs/0903.5008>  
 Paper: <http://arxiv.org/ftp/arxiv/papers/0903/0903.5008.pdf>
2. AB Blanket for Cities (for continual pleasant weather and protection from chemical, biological and radioactive weapons).  
<http://arxiv.org/ftp/arxiv/papers/0902/0902.0656.pdf>
3. A Cheap Levitating Gas/Load Pipeline. <http://arxiv.org/ftp/arxiv/papers/0812/0812.0588.pdf>
4. Magnetic Propeller for Uniform Magnetic Field Levitation.  
<http://arxiv.org/ftp/arxiv/papers/0807/0807.1948.pdf>
5. In Outer Space without a Space Suit? <http://arxiv.org/ftp/arxiv/papers/0806/0806.3792.pdf>
6. AB-Electronic Tubes and Quasi-Superconductivity at Room Temperature.  
<http://arxiv.org/ftp/arxiv/papers/0805/0805.0230.pdf>
7. Floating Cities, Islands and States. <http://arxiv.org/ftp/arxiv/papers/0804/0804.0754.pdf>
8. Thermonuclear Reflect AB-Reactor. <http://arxiv.org/ftp/arxiv/papers/0803/0803.3776.pdf>
9. AB Space Engine. <http://arxiv.org/ftp/arxiv/papers/0803/0803.0089.pdf>
10. AB-Net Method of Protection from Projectiles (city, military base, battle-front, etc.)  
<http://arxiv.org/ftp/arxiv/papers/0802/0802.1871.pdf>
11. Protection of Cities from Small Rockets, Missiles, Projectiles and Mortar Shells  
<http://arxiv.org/ftp/arxiv/papers/0802/0802.0315.pdf>
12. Cheap Artificial AB-Mountains, Extraction of Water and Energy from Atmosphere and Change of Regional Climate. <http://arxiv.org/ftp/arxiv/papers/0801/0801.4820.pdf> .
13. Cheap Method for Shielding a City from Rocket and Nuclear Warhead Impacts.  
<http://arxiv.org/ftp/arxiv/papers/0801/0801.1694.pdf>
14. AB Method of Irrigation without Water (Closed-loop water cycle).  
<http://arxiv.org/ftp/arxiv/papers/0712/0712.3935.pdf>
15. Protection of New York City Urban Fabric With Low-Cost Textile Storm Surge Barriers.  
<http://arxiv.org/ftp/arxiv/papers/0710/0710.0195.pdf>
16. AB Levitrons and their Applications to Earth's Motionless Satellites.  
<http://arxiv.org/ftp/arxiv/papers/0708/0708.2489.pdf>
17. Inflatable Dome for Moon, Mars, Asteroids and Satellites  
<http://arxiv.org/ftp/arxiv/papers/0707/0707.3990.pdf>

18. Global Sea Level Stabilization-Sand Dune Fixation: A Solar-powered Sahara Seawater Textile Pipeline. <http://arxiv.org/ftp/arxiv/papers/0707/0707.3234.pdf>
19. New AB-Thermonuclear Reactor for Aerospace. <http://arxiv.org/ftp/arxiv/papers/0706/0706.2182.pdf>
20. Electrostatic Climber for Space Elevator and Launcher. <http://arxiv.org/ftp/arxiv/papers/0705/0705.1943.pdf>
21. Optimal Electrostatic Space Tower (Mast, New Space Elevator). <http://arxiv.org/ftp/arxiv/papers/0704/0704.3466.pdf>
22. Extraction of Freshwater and Energy from Atmosphere. <http://arxiv.org/ftp/arxiv/papers/0704/0704.2571.pdf>
23. Passenger life-saving in a badly damaged aircraft scenario. <http://arxiv.org/ftp/physics/papers/0703/0703259.pdf>
24. Lake Titicaca - Physics of an Inherited Hydropower Macroproject Proposal <http://arxiv.org/ftp/physics/papers/0703/0703182.pdf>
25. AB Levitator and Electricity Storage. <http://arxiv.org/ftp/physics/papers/0703/0703013.pdf>
26. The Golden Gate Textile Barrier: Preserving California Bay of San Francisco from a Rising North Pacific Ocean. <http://arxiv.org/ftp/physics/papers/0702/0702030.pdf>
27. Design of Optimal Regulators. <http://arxiv.org/ftp/math/papers/0701/0701551.pdf>
28. Simplest AB-Thermonuclear Space Propulsion and Electric Generator . <http://arxiv.org/ftp/physics/papers/0701/0701226.pdf>
29. Air Observe System. <http://arxiv.org/ftp/physics/papers/0701/0701115.pdf>
30. Utilization of Wind Energy at High Altitude <http://arxiv.org/ftp/physics/papers/0701/0701114.pdf>
31. Ocean Terracing. <http://arxiv.org/ftp/physics/papers/0701/0701100.pdf>
32. The Java-Sumatra Aerial Mega-Tramway <http://arxiv.org/ftp/physics/papers/0701/0701099.pdf>
33. Inflatable Evergreen Polar Zone Dome (EPZD) Settlements <http://arxiv.org/ftp/physics/papers/0701/0701098.pdf>
34. Control of Regional and Global Weather <http://arxiv.org/ftp/physics/papers/0701/0701097.pdf>
35. Micro -Thermonuclear AB-Reactors for Aerospace <http://arxiv.org/ftp/physics/papers/0701/0701095.pdf>
36. A New Method of Atmospheric Reentry for Space Ships <http://arxiv.org/ftp/physics/papers/0701/0701094.pdf>
37. Optimal Solid Space Tower. <http://arxiv.org/ftp/physics/papers/0701/0701093.pdf>
38. High Speed AB-Solar Sail. <http://arxiv.org/ftp/physics/papers/0701/0701073.pdf>
39. Electrostatic AB-Ramjet Space Propulsion <http://arxiv.org/ftp/physics/papers/0701/0701073.pdf>
40. A Low-Cost Natural Gas/Freshwater Aerial Pipeline <http://arxiv.org/ftp/physics/papers/0701/0701061.pdf>
41. Theory of Space Magnetic Sail Some Common Mistakes and Electrostatic MagSail . <http://arxiv.org/ftp/physics/papers/0701/0701060.pdf>
42. Cheap Textile Dam Protection of Seaport Cities against Hurricane Storm Surge Waves, Tsunamis, and Other Weather-Related Floods <http://arxiv.org/ftp/physics/papers/0701/0701059.pdf>

43. Wireless Transfer of Electricity in Outer Space.  
<http://arxiv.org/ftp/physics/papers/0701/0701058.pdf>
44. Beam Space Propulsion. <http://arxiv.org/ftp/physics/papers/0701/0701057.pdf>
45. Antarctica: A Southern Hemisphere Windpower Station?  
 Journal-ref: Bolonkin, A.A. (2004) Utilization of Wind Energy at High Altitude, Presented at International Energy Conversion Engineering Conference at Providence, RI, 16-19 August 2004, AIAA-2004-5705. <http://arxiv.org/ftp/physics/papers/0701/0701055.pdf>

## **Bolonkin's reports (41) in AIAA** (The American Institute of Aeronautics and Astronautics) Conferences

### **1. Electrostatic Climber for Space Elevator and Launcher**

Alexander Bolonkin CandR, Brooklyn, NY, UNITED STATES

AIAA-2007-5838

43rd AIAA/ASME/SAE/ASEE Joint Propulsion Conference and Exhibit, Cincinnati, OH, July 8-11, 2007 .

[http://pdf.aiaa.org/preview/CDReadyMJPC07\\_1492/PV2007\\_5838.pdf](http://pdf.aiaa.org/preview/CDReadyMJPC07_1492/PV2007_5838.pdf)

SEE FIRST PAGE »

ADD TO CART »

### **2. Electrostatic Linear Engine**

Alexander Bolonkin CandR, Brooklyn, NY, UNITED STATES

AIAA-2006-5229

42nd AIAA/ASME/SAE/ASEE Joint Propulsion Conference and Exhibit, Sacramento, California, July 9-12, 2006

[http://pdf.aiaa.org/preview/CDReadyMJPC06\\_1178/PV2006\\_5229.pdf](http://pdf.aiaa.org/preview/CDReadyMJPC06_1178/PV2006_5229.pdf)

SEE FIRST PAGE »

ADD TO CART »

### **3. Electrostatic Solar Wind Propulsion System**

Alexander Bolonkin , Brooklyn, NY, UNITED STATES

AIAA-2005-3653

41st AIAA/ASME/SAE/ASEE Joint Propulsion Conference and Exhibit, Tucson, Arizona, July 10-13, 2005

[http://pdf.aiaa.org/preview/CDReadyMJPC2005\\_1177/PV2005\\_3653.pdf](http://pdf.aiaa.org/preview/CDReadyMJPC2005_1177/PV2005_3653.pdf)

SEE FIRST PAGE »

ADD TO CART »

### **4. Thermonuclear Reflect AB-Reactor for Aerospace**

Alexander Bolonkin CandR, Brooklyn, NY, UNITED STATES  
AIAA-2008-5150  
44th AIAA/ASME/SAE/ASEE Joint Propulsion Conference and Exhibit, Hartford,  
CT, July 21-23, 2008  
[http://pdf.aiaa.org/preview/CDReadyMJPC08\\_1874/PV2008\\_5150.pdf](http://pdf.aiaa.org/preview/CDReadyMJPC08_1874/PV2008_5150.pdf)

[SEE FIRST PAGE »](#)[ADD TO CART »](#)

## 5. Beam Space Propulsion

Alexander Bolonkin C and R Company, Brooklyn, NY, UNITED STATES  
AIAA-2006-7492  
Space 2006, San Jose, California, Sep. 19-21, 2006  
[http://pdf.aiaa.org/preview/CDReadyMSPACE06\\_1393/PV2006\\_7492.pdf](http://pdf.aiaa.org/preview/CDReadyMSPACE06_1393/PV2006_7492.pdf)

[SEE FIRST PAGE »](#)[ADD TO CART »](#)

## 6. Micro-Thermonuclear AB-Reactors for Aerospace

Alexander Bolonkin CandR, Brooklyn, NY, UNITED STATES  
AIAA-2006-8104  
14th AIAA/AHI Space Planes and Hypersonic Systems and Technologies  
Conference, Canberra, Australia, Nov. 6-9, 2006  
[http://pdf.aiaa.org/preview/CDReadyMHYP06\\_1276/PV2006\\_8104.pdf](http://pdf.aiaa.org/preview/CDReadyMHYP06_1276/PV2006_8104.pdf)

[SEE FIRST PAGE »](#)[ADD TO CART »](#)

## 7. Electrostatic Space Towers

Alexander Bolonkin CandR, Brooklyn, NY, UNITED STATES  
AIAA-2007-6201  
AIAA SPACE 2007 Conference and Exposition, Long Beach, California, Sep. 18-  
20, 2007  
[http://pdf.aiaa.org/preview/CDReadyMSPACE07\\_1808/PV2007\\_6201.pdf](http://pdf.aiaa.org/preview/CDReadyMSPACE07_1808/PV2007_6201.pdf)

[SEE FIRST PAGE »](#)[ADD TO CART »](#)

## 8. High Speed Catapult Aviation

Alexander Bolonkin CandR Company, Brooklyn, NY, UNITED STATES  
AIAA-2005-6221  
AIAA Atmospheric Flight Mechanics Conference and Exhibit, San Francisco,  
California, Aug. 15-18, 2005

[SEE FIRST PAGE »](#)[ADD TO CART »](#)

## 9. High Efficiency Transfer of Mechanical Energy

Alexander Bolonkin Eglin AFB, Brooklyn, NY, UNITED STATES  
AIAA-2004-5660  
2nd International Energy Conversion Engineering Conference, Providence, Rhode Island, Aug. 16-19, 2004

[SEE FIRST PAGE »](#) [ADD TO CART »](#)

## 10. AB-Space Propulsion

Alexander Bolonkin CandR, Brooklyn, NY, UNITED STATES  
AIAA-2008-5151  
44th AIAA/ASME/SAE/ASEE Joint Propulsion Conference and Exhibit, Hartford, CT, July 21-23, 2008

[SEE FIRST PAGE »](#) [ADD TO CART »](#)

## 11. Wireless Transfer of Electricity in Outer Space

Alexander Bolonkin CandR, Brooklyn, NY, UNITED STATES  
AIAA-2007-590  
45th AIAA Aerospace Sciences Meeting and Exhibit, Reno, Nevada, Jan. 8-11, 2007

[SEE FIRST PAGE »](#) [ADD TO CART »](#)

## 12. Electrostatic Utilization of Asteroids for Space Flight

Alexander Bolonkin , Brooklyn, NY, UNITED STATES  
AIAA-2005-4032  
41st AIAA/ASME/SAE/ASEE Joint Propulsion Conference and Exhibit, Tucson, Arizona, July 10-13, 2005

[SEE FIRST PAGE »](#) [ADD TO CART »](#)

## 13. Kinetic Anti-Gravitator

Alexander Bolonkin , Brooklyn, NY, UNITED STATES  
AIAA-2005-4504  
41st AIAA/ASME/SAE/ASEE Joint Propulsion Conference and Exhibit, Tucson, Arizona, July 10-13, 2005

[SEE FIRST PAGE »](#) [ADD TO CART »](#)

## 14. Developing Conception of Faraday Motor. Space Trolley Buss



Alexander Bolonkin CandR, Brooklyn, NY, UNITED STATES; Mark Krinker City University of New York, Bronx, NY, UNITED STATES  
AIAA-2009-6664  
AIAA SPACE 2009 Conference and Exposition, Pasadena, California, Sep. 14-17, 2009

[SEE FIRST PAGE »](#)[ADD TO CART »](#)

### **15. Utilization of Wind Energy at High Altitude**

Alexander Bolonkin Eglin AFB, Brooklyn, NY, UNITED STATES  
AIAA-2004-5705  
2nd International Energy Conversion Engineering Conference, Providence, Rhode Island, Aug. 16-19, 2004

[SEE FIRST PAGE »](#)[ADD TO CART »](#)

### **16. Magnetic Field-Based Conception of an Orbital Flight**

Alexander Bolonkin CandR, Brooklyn, NY, UNITED STATES; Mark Krinker CUNY, Bronx, NY, UNITED STATES  
AIAA-2009-5340  
45th AIAA/ASME/SAE/ASEE Joint Propulsion Conference and Exhibit, Denver, Colorado, Aug. 2-5, 2009

[SEE FIRST PAGE »](#)[ADD TO CART »](#)

### **17. Sling Rotary Space Launcher**

Alexander Bolonkin , Brooklyn, NY, UNITED STATES  
AIAA-2005-4035  
41st AIAA/ASME/SAE/ASEE Joint Propulsion Conference and Exhibit, Tucson, Arizona, July 10-13, 2005

[SEE FIRST PAGE »](#)[ADD TO CART »](#)

### **18. New High Speed AB-Solar Sail**

Alexander Bolonkin CandR, Brooklyn, NY, UNITED STATES  
AIAA-2006-4806  
42nd AIAA/ASME/SAE/ASEE Joint Propulsion Conference and Exhibit, Sacramento, California, July 9-12, 2006

[SEE FIRST PAGE »](#)[ADD TO CART »](#)

## 19. Magnetic Space Launcher

Alexander Bolonkin CandR, Brooklyn, NY, UNITED STATES; Mark Krinker City University of New York, Brooklyn, NY, UNITED STATES  
AIAA-2009-5261  
45th AIAA/ASME/SAE/ASEE Joint Propulsion Conference and Exhibit, Denver, Colorado, Aug. 2-5, 2009

[SEE FIRST PAGE »](#)[ADD TO CART »](#)

## 20. Magnetic Propeller for Uniform Magnetic Field Levitation

Mark Krinker CandR, Bronx, NY, UNITED STATES; Alexander Bolonkin CandR, Brooklyn, NY, UNITED STATES  
AIAA-2008-4610  
44th AIAA/ASME/SAE/ASEE Joint Propulsion Conference and Exhibit, Hartford, CT, July 21-23, 2008

[SEE FIRST PAGE »](#)[ADD TO CART »](#)

## 21. Guided Solar Sail and Energy Generator

Alexander Bolonkin , Brooklyn, NY, UNITED STATES  
AIAA-2005-3857  
41st AIAA/ASME/SAE/ASEE Joint Propulsion Conference and Exhibit, Tucson, Arizona, July 10-13, 2005

[SEE FIRST PAGE »](#)[ADD TO CART »](#)

## 22. Passenger Life-Saving in a Badly Damaged Aircraft Scenario

Alexander Bolonkin CandR, Brooklyn, NY, UNITED STATES  
AIAA-2007-5844  
43rd AIAA/ASME/SAE/ASEE Joint Propulsion Conference and Exhibit, Cincinnati, OH, July 8-11, 2007

[SEE FIRST PAGE »](#)[ADD TO CART »](#)

## 23. Optimal Solid Space Tower

Alexander Bolonkin CandR, Brooklyn, NY, UNITED STATES  
AIAA-2007-367  
45th AIAA Aerospace Sciences Meeting and Exhibit, Reno, Nevada, Jan. 8-11, 2007

[SEE FIRST PAGE »](#) [ADD TO CART »](#)

## **24. Radioisotope Space Sail and Electro-Generator**

Alexander Bolonkin , Brooklyn, NY, UNITED STATES

AIAA-2005-4225

41st AIAA/ASME/SAE/ASEE Joint Propulsion Conference and Exhibit, Tucson, Arizona, July 10-13, 2005

[SEE FIRST PAGE »](#) [ADD TO CART »](#)

## **25. Problems of Electrostatic Levitation and Artificial Gravity**

Alexander Bolonkin , Brooklyn, NY, UNITED STATES

AIAA-2005-4465

41st AIAA/ASME/SAE/ASEE Joint Propulsion Conference and Exhibit, Tucson, Arizona, July 10-13, 2005

[SEE FIRST PAGE »](#) [ADD TO CART »](#)

## **26. A New Type of Thermonuclear Reactor for Aerospace**

Alexander Bolonkin C and R Technologies, Brooklyn, NY, UNITED STATES

AIAA-2006-7275

Space 2006, San Jose, California, Sep. 19-21, 2006

[SEE FIRST PAGE »](#) [ADD TO CART »](#)

## **27. Air Cable Transport System**

Alexander Bolonkin,

Journal of Aircraft 2003

0021-8669 vol.40 no.2 (265-269)

doi: 10.2514/2.3118

[SEE FIRST PAGE »](#) [ADD TO CART »](#)

## **28. Design of Optimal Regulators**

Alexander Bolonkin Air Force Research Laboratory, Eglin AFB, FL, UNITED STATES; Robert Sierakowski Air Force Research Laboratory, Eglin AFB, FL, UNITED STATES

AIAA-2003-6638

2nd AIAA "Unmanned Unlimited" Conf. and Workshop and Exhibit, San Diego, California, Sep. 15-18, 2003

[SEE FIRST PAGE »](#) [ADD TO CART »](#)

### **29. Converting of Matter to Energy by AB-Generator and Photon Rocket**

Alexander Bolonkin CandR, Brooklyn, NY, UNITED STATES

AIAA-2009-5342

45th AIAA/ASME/SAE/ASEE Joint Propulsion Conference and Exhibit, Denver, Colorado, Aug. 2-5, 2009

[SEE FIRST PAGE »](#)

[ADD TO CART »](#)

### **30. Geometry-Based Parametric Modeling For Single-Pursuer Multiple Evader Problems**

A. Bolonkin, Eglin AF Base; R. Murphey, Eglin AF Base

Journal of Guidance, Control, and Dynamics 2005

0731-5090 vol.28 no.1 (145-149)

doi: 10.2514/1.4959

[SEE FIRST PAGE »](#)

[ADD TO CART »](#)

### **31. Method for finding a global minimum**

Bolonkin, A. A., USAF, Flight Dynamics Directorate, Wright-Patterson AFB, OH; Khot, N. S.,

USAF, Flight Dynamics Directorate, Wright-Patterson AFB, OH

AIAA-1994-4420

[SEE FIRST PAGE »](#)

[ADD TO CART »](#)

### **32. Theory of Space Magnetic Sail Some Common Mistakes and Electrostatic MagSail**

Alexander Bolonkin CandR, Brooklyn, NY, UNITED STATES

AIAA-2006-8148

14th AIAA/AHI Space Planes and Hypersonic Systems and Technologies Conference, Canberra, Australia, Nov. 6-9, 2006

[SEE FIRST PAGE »](#)

[ADD TO CART »](#)

### **33. Geometry-Based Parametric Modeling for Single Pursuer Multiple Evader Problems**

Alexander Bolonkin Air Force Research Laboratory, Eglin AFB, FL, UNITED STATES; Robert

Murphey Air Force Research Laboratory, Eglin AFB, FL, UNITED STATES

AIAA-2003-6611

2nd AIAA "Unmanned Unlimited" Conf. and Workshop and Exhibit, San Diego, California, Sep. 15-18, 2003

[SEE FIRST PAGE »](#)

[ADD TO CART »](#)

### **34. A New Method of Atmospheric Reentry for Space Shuttles**

Alexander Bolonkin CandR, Brooklyn, NY, UNITED STATES

AIAA-2006-6985

11th AIAA/ISSMO Multidisciplinary Analysis and Optimization Conference, Portsmouth, Virginia, Sep. 6-8, 2006

[SEE FIRST PAGE »](#) [ADD TO CART »](#)

### **35. Theory of Space Magnetic Sail and Electrostatic MagSail**

Alexander Bolonkin CandR, Brooklyn, NY, UNITED STATES

AIAA-2007-499

45th AIAA Aerospace Sciences Meeting and Exhibit, Reno, Nevada, Jan. 8-11, 2007

[SEE FIRST PAGE »](#) [ADD TO CART »](#)

### **36. Some Optimal Problems in Search, Observation, and Attack**

Alexander Bolonkin Air Force Research Laboratory, Brooklyn, NY, UNITED STATES; James

Cloutier U.S. Air Force Research Laboratory, Eglin AFB, FL, UNITED STATES

AIAA-2005-6232

AIAA Atmospheric Flight Mechanics Conference and Exhibit, San Francisco, California, Aug. 15-18, 2005

[SEE FIRST PAGE »](#) [ADD TO CART »](#)

### **37. Inflatable Dome for Moon, Mars, Asteroids, and Satellites**

Alexander Bolonkin CandR, Brooklyn, NY, UNITED STATES

AIAA-2007-6262

AIAA SPACE 2007 Conference and Exposition, Long Beach, California, Sep. 18-20, 2007

[SEE FIRST PAGE »](#) [ADD TO CART »](#)

### **38. Hypersonic Gas-Rocket Launch System**

Alexander Bolonkin NJIT, Fort Walton Beach, FL, UNITED STATES

AIAA-2002-3927

38th AIAA/ASME/SAE/ASEE Joint Propulsion Conference and Exhibit, Indianapolis, Indiana, July 7-10, 2002

[SEE FIRST PAGE »](#) [ADD TO CART »](#)

### **39. Overview of Advanced Concepts for Space Access**

Andrew Ketsdever, U.S. Air Force Research Laboratory; Marcus Young, U.S. Air Force Research Laboratory; Jason Mossman, U.S. Air Force Research Laboratory; Anthony Pancotti, ERC, Inc.  
 Journal of Spacecraft and Rockets 2010  
 0022-4650 vol.47 no.2 (238-250)  
 doi: 10.2514/1.46148

[SEE FIRST PAGE »](#)

[ADD TO CART »](#)

#### **40. Search and Attack Strategies**

Alexander Bolonkin U.S. Air Force Research Laboratory, Eglin AFB, FL, UNITED STATES;  
 James Cloutier U.S. Air Force Research Laboratory, Eglin AFB, FL, UNITED STATES  
 AIAA-2005-6403  
 AIAA Guidance, Navigation, and Control Conference and Exhibit, San Francisco, California, Aug.  
 15-18, 2005

[SEE FIRST PAGE »](#)

[ADD TO CART »](#)

#### **41. Search and Attack Strategies**

Alexander Bolonkin Eglin AFB, Brooklyn, NY, UNITED STATES; James Cloutier Eglin AFB, Eglin,  
 FL, UNITED STATES  
 AIAA-2004-5424  
 AIAA Guidance, Navigation, and Control Conference and Exhibit, Providence, Rhode Island, Aug.  
 16-19, 2004

[SEE FIRST PAGE »](#)

[ADD TO CART »](#)

### **JBIS (Journal of British Interplanetary Society).**

1. A cable Space Transport System at the Earth's Poles to Support Exploration of the Moon, JBIS, Vol.59, No. 10, Oct. 2006, pp. 375-380.
2. Kinetic Space Towers and Launchers, Vol.57, No.1/2, Jan/Feb., 2004, pp.33-39.
3. Hypersonic Gas-Rocket Launcher of High Capacity, Vol.57, No.5/6, May/June 2004, pp. 162-172.
4. Light Multi-Reflex Engine, Vol.57, No. 9/10, Sep/Oct. 2004, pp. 353-359.
5. Multi-Reflex Propulsion Systems for space and Air Vehicles and Energy Transfer for Long Distance, Vol.57, No.11/12, Nov/Dec. 2004, pp. 379-390.
6. Earth Accelerator for Space Ships and Missiles, Vol.56, No.11/12, Nov/Dec. 2003, pp. 394-403.
7. Non-Rocket Transport System for Space Travel, Vol. 56, No.7/8, July/Aug., 2003, pp. 231-249.
8. Centrifugal Keeper for Space Stations and Satellites, Vol. 56, No.9/10, Sep/Oct., 2003,

pp.314-327.

9. Optimal Inflatable Space Towers with 3 – 100 km Height, Vol.56, No. ¾, March/Apr., 2003, pp.87-96.

## Journal AEAT ([Aircraft Engineering and Aerospace Technology](#))

### 1. Non-Rocket Space Launch and Flight

Type: Non-article

Author(s): A. Bolonkin

Source: [Aircraft Engineering and Aerospace Technology](#) Volume: 78 [Issue: 5](#) 2006

Please login | [Abstract](#) [HTML available] | [Related items](#)

---

2

### Electrostatic linear engine

1 paper

Author(s): Alexander Bolonkin

Source: [Aircraft Engineering and Aerospace Technology](#) Volume: 78 [Issue: 6](#) 2006

[Preview](#) | [Abstract & purchase](#) [HTML & PDF (649kb) available] | [Related items & permissions](#)

---

3

### Beam space propulsion

Type: Research paper

Author(s): Alexander Bolonkin

Source: [Aircraft Engineering and Aerospace Technology](#) Volume: 80 [Issue: 2](#) 2008

Please login | [Preview](#) | [Abstract & purchase](#) [HTML & PDF (542kb) available] | [Related items](#) | [Reprints & permissions](#)

---

4

### Electrostatic AB-Ramjet space propulsion for interplanetary flight

Type: Research paper

Author(s): Alexander Bolonkin

Source: [Aircraft Engineering and Aerospace Technology](#) Volume: 79 [Issue: 1](#) 2007

Please login | [Preview](#) | [Abstract & purchase](#) [HTML & PDF (797kb) available] | [Related items](#) | [Reprints & permissions](#)

---

5

### Simplest AB-thermonuclear space propulsion and electric generator

Type: Research paper

Author(s): Alexander Bolonkin

Source: [Aircraft Engineering and Aerospace Technology](#) Volume: 80 [Issue: 1](#) 2008

Please login | [Preview](#) | [Abstract & purchase](#) [HTML & PDF (175kb) available] | [Related items](#) | [Reprints & permissions](#)

---

6

### Transfer of electricity in space

Type: Research paper

Author(s): Alexander Bolonkin

Source: [Aircraft Engineering and Aerospace Technology](#) Volume: 79 [Issue: 3](#) 2007

Please login | [Preview](#) | [Abstract & purchase](#) [HTML & PDF (436kb) available] | [Related items](#) | [Reprints & permissions](#)

---

7

### Passenger life-saving in a badly damaged aircraft scenario

Type: Research paper

Author(s): Alexander Bolonkin

Source: [Aircraft Engineering and Aerospace Technology](#) Volume: 80 [Issue: 6](#) 2008

Please login | [Preview](#) | [Abstract & purchase](#) [HTML & PDF (627kb) available] | [Related items](#) | [Reprints & permissions](#)

---



8

**AB levitator and electricity storage**

Type: General review

Author(s): Alexander Bolonkin

Source: [Aircraft Engineering and Aerospace Technology](#) Volume: 80 [Issue: 4](#) 2008Please login | [▼ Preview](#) | [Abstract & purchase](#) [ HTML & PDF (379kb) available ] | [Related items](#) | [Reprints & permissions](#)

9

**Micro-thermonuclear AB-reactors for aviation**

Type: Research paper

Author(s): Alexander Bolonkin

Source: [Aircraft Engineering and Aerospace Technology](#) Volume: 79 [Issue: 6](#) 2007Please login | [▼ Preview](#) | [Abstract & purchase](#) [ HTML & PDF (734kb) available ] | [Related items](#) | [Reprints & permissions](#)

10

**. Optimal trajectories of air and space vehicles**

Type: Research paper

Author(s): Alexander Bolonkin

Source: [Aircraft Engineering and Aerospace Technology](#) Volume: 76 [Issue: 2](#) 2004Please login | [▼ Preview](#) | [Abstract & purchase](#) [ HTML & PDF (1867kb) available ] | [Related items](#) | [Reprints & permissions](#)**Popular articles in Russian press:**

- [\[Edit\]](#) [\[Textedit\]](#) [Пост-человеческая цивилизация. XXI век: Конец человечеству и возникновение пост-человеческого общества](#) **33k** Публицистика

Д.т.н. Александр Болонкин говорит о том, что биологическое человечество есть только ступенька к новой более высокой электронной цивилизации.

- [\[Edit\]](#) [\[Textedit\]](#) [Xx1 век - начало бессмертия людей](#) **25k** Публицистика

Д.т.н. Александр Болонкин обсуждает будущую возможность бессмертия людей в новом электронном облике и преимущества их нового существования

- [\[Edit\]](#) [\[Textedit\]](#) [Поселим Бога в компьютер-интернетовскую сеть](#) **24k** Публицистика [Комментарии: 2 \(11/10/2002\)](#)

Автор предлагает использовать Всемирную компьютер-интернетовскую сеть для создания Высшего Разума.

- [\[Edit\]](#) [\[Textedit\]](#) [Американская и Мировая науки](#) **21k** Публицистика

Рассматривается нынешнее состояние и перспективы развития американской и мировой науки

- [\[Edit\]](#) [\[Textedit\]](#) [НАСА: Достижения и перспективы](#) **13k** Оценка:4.09\*6

Публицистика [Комментарии: 1 \(11/10/2002\)](#)

Старший научный сотрудник НАСА д.т.н. Александр Болонкин рассказывает о работе Американского Ведомства космических исследований

- [\[Edit\]](#) [\[Textedit\]](#) [Особенности советской и американской науки](#) **16k** Публицистика

Д.т.н., профессор Александр Болонкин, проработавший много лет в советской и американской науке, рассказывает об их особенностях, преимуществах и недостатках.