

Time as Energy

14th April 2019.

Stephen H. Jarvis.

<http://orcid.org/0000-0003-3869-7694> (ORCID)

EQUUS AEROSPACE PTY LTD

Web: www.equusspace.com

email: shj@equusspace.com

Abstract: In this development upon four previous papers [1][2][3][4], we shall finally explain the link between the idea of “time” and “energy”, bringing parity between time and energy while explaining why quantum entanglement [5] as a concept is “immediate” (breaking the confines of time itself). First, we shall integrate the idea of time as energy into all the references made regarding energy in the four preceding papers, to demonstrate the consistency and greater detail available to the theory via this method of time-energy regard. Then, we shall derive the temperature of the background microwave radiation [6] in expanding upon paper 4, highlighting entropy as the cosmic microwave background radiation. Finally, we will then be able to propose the nature of the appearance of the universe of stars in this new context, through this new filter of time-energy regard.

Keywords: time; energy; quantum entanglement; cosmic microwave background radiation; CMB; heat; temperature; fine structure constant, gauge invariance; fractal; entropy; Avogadro; theory of everything; probability wave; gas constant; Voyager 1

1. Introduction.

In the first paper [1], the new algorithm for time was presented describing new basic principles for time and energy; a new logic for space and time was presented that aimed to cleanly knit time (as energy) with space (as mass-reference). From this, a basic wave-function was developed for the propagation of what appeared to be “energy” in space. With this wave function and associated equation, we developed equations for electromagnetism and gravity, and from there equations for the electron/energy shells of the atom. Simply, a new principle for time

as an equation was put to a new 3-d spatial manifold of determination, while being put up against what we already know of atomic particle and energy congress. The first paper was doing well, yet had many gaps in it.

The second paper dived deeper into the logic of the wave-function, presenting the logic behind time seeking to trace a “perfect circle”. In this way, we estimated the value of the fine structure constant of the atom from these new first principles for time and space, a feat not yet achieved in physics theory (namely the derivation of a dimensionless constant such as the fine structure constant value). Along with the value of the fine structure constant we were able to propose a type of substructure to the fine structure constant, the elementary particle level. Once again, we were pitching a new idea of the golden ratio up against what we had already theorised for the atom based on our current understanding of quantum mechanics.

The third paper took a slight departure from the normal direction of physics theory and suggested that our ability to be conscious could well be a “process” that emerges from the fundamental need for time as energy to trace a perfect circle; we derived the chaos equation, forwarded an explanation for Brownian motion, and proposed the general behaviour of the cosmos would be. It was a paper with generalisations and sweeping proposals, yet done so unashamedly in the context of forwarding the idea of time operating per a basic golden ratio principle. This was the paper where “extra-atomic” time was defined as chaos, as t_A (t_B^2) and gauge invariance [7] considered fundamental to atomic interactions.

The fourth paper, in accepting the vast number of unsubstantiated proposals in the new theory for time, decided to directly examine the wave-function for time (as energy). Here, the new wave-function essentially replaced the Schrodinger equation. This was so, as we were able to explain the uncertainty principle, quantum entanglement, and why light can behave as a wave and a particle, with this new phi-quantum wave-function. This paper, using the new proposed phi-quantum wave-function, was able to present a basis for the existence of elementary particles, their relationship to one another, and how they can gather and emerge to the level of the atom. As per paper three and the idea of chaos theory with “initial conditions”, the proposal was made that features of the atom would extend beyond the atom in a “fractal” manner. With the new phi-quantum wave-function, we then proposed that the inherent error in the π -calculation in the wave-function accounts for the disparity between mass and number of atomic particles. We did this by deriving a value consistent with Avogadro’s number (~1% error); we were able to suggest that this error value as emergent time represents a frequency that itself has a strong correlation with the value of the background microwave radiation, suggesting that the background microwave radiation may not be a result of a big-bang but an ever-present feature of time and space.

So the stage has been set to run a common thread of logic through all these papers, to highlight time as energy as a fundamental principle, a consistency that is able to derive a fundamental constant (the fine structure constant), the equations for gravity and electromagnetism, the electron shell structure of the atom, and associated quantum features of electron mechanics, the elementary particle realm, the idea of chaos and fractal growth (gauge invariance), Avogadro’s number, and the cosmic microwave background radiation value. That’s a lot, and could even constitute a ‘theory of everything’ [8]. We need to do two more things though before any such theory could be considered. The first is to explain the basic feature of time and energy, for we have been vague about those two concepts: is time energy, and how does this intricately relate to space? How can this be explained as “spooky action at a distance” (as per quantum entanglement), for instance? The next thing we must explain, or rather prove, is a new phenomenon that current theories of physics cannot account for, and here shall be proposed and forwarded in a subsequent “white” paper an experiment that should prove the emergence of gravity from electrodynamics, the theme of paper 2, carried through to this paper.

2. Time and Energy: a paper retrospective

What are we saying about energy, can we be more precise, what are the fundamentals regarding time and energy thus far, what words have we used, and can we be more descript; is time directly related to energy, is time merely energy, or is there a more mathematical description to it? Let's dissect the previous four papers [1][2][3][4].

2.1 General dissection of the initial four papers:

([1], p2): *A "location" in space is defined as a "zero" reference in an overall universal 0-scalar space 3-d manifold. What we're proposing here is that which gives space it's feature, of "cradling" everything, is "time"; as one space cannot be elsewhere, the effect of time "changes" a reference of space, gives each 0-scalar point of space it's "uniqueness".*

([1], p3): *This streaming package of time would "vibrate" from one state S_1 to the next S_2 , and back again (a most basic consideration), as per an "up" position to a "down" position and back again, etc., as a feature of its presence "in" space. Furthermore, if space is as 0-scalar, then time is not; time would be "eternal" in comparison to space. Time would also be "different" to space's emptiness, as let's say a thing called energy, that which gives space it's "power", its "flux". Let's also say that time is a feature not just of energy, but "light", as space is not. By contemporary accounts a package of time could well be a "quanta" of light. Yet if light is "energy" and reality as we know it operates according to a process of entropy [6], increasing randomness, then "time" has an interesting feature that requires more investigating as it flows from t_B to t_A .*

So, we're suggesting that the idea of time is in fact "energy". It's a bold statement, almost suggesting that 'time' is "light", and that without light there is no time. Yet, how reality is constructed almost carries with it a greater agenda, as we discovered in section three with the suggestion that time aims to trace a perfect circle. Surely, we can be more specific with the understanding of time following all the proposals regarding the behaviour of time that developed over the course of the four papers thus far? For instance, can time ever run out, was there a beginning to time, will there be an end? Can we explain the idea of an increase in energy of a system seeming to make each time-event "shorter"/smaller" (and thus "faster")?

The real indication of what time is as an emergent feature of the phi-quantum wave-function, as per paper 4 [4], can be found with the knowledge contained in paper [2] regarding the phi-quantum wave-function, that " $\frac{-1}{\phi}$ " is a factor used as time for t_B , ([2]; eq3 p8), and " ϕ " is used as the factor for t_A as ϕ^2 ([2]; eq5 p10). In other words, these features are embedded already in the phi-quantum wave-function. The only possible features thus that "can" be used as emergent time from the level of the atom would be " ϕ for t_B " and " $\frac{1}{\phi^2}$ for t_A ". Thus, the energy of a reference in space as time would correspond to a value of t_B as ϕ which then as t_A becomes as $\frac{1}{\phi^2}$ (or simply as $\frac{1}{t_B^2}$). And this is in fact true regarding the value of the energy of a wave-function as it progresses through space, namely dependent on the idea of energy being proportional to c-squared and thus inversely proportional to time-squared in proportion to the distance-squared it travels through. Hence, we can therefore suggest that as the time of an event shortens, gets smaller, in comparison to another event, as t_B is smaller regarding t_A , its energy therefore as t_A increases, as per the fact $\frac{1}{t_B^2}$ gets greater in value the smaller t_B becomes. Thus, consider the figure 1 as an extension of ([2]; fig16 p16) explaining the progression of time.

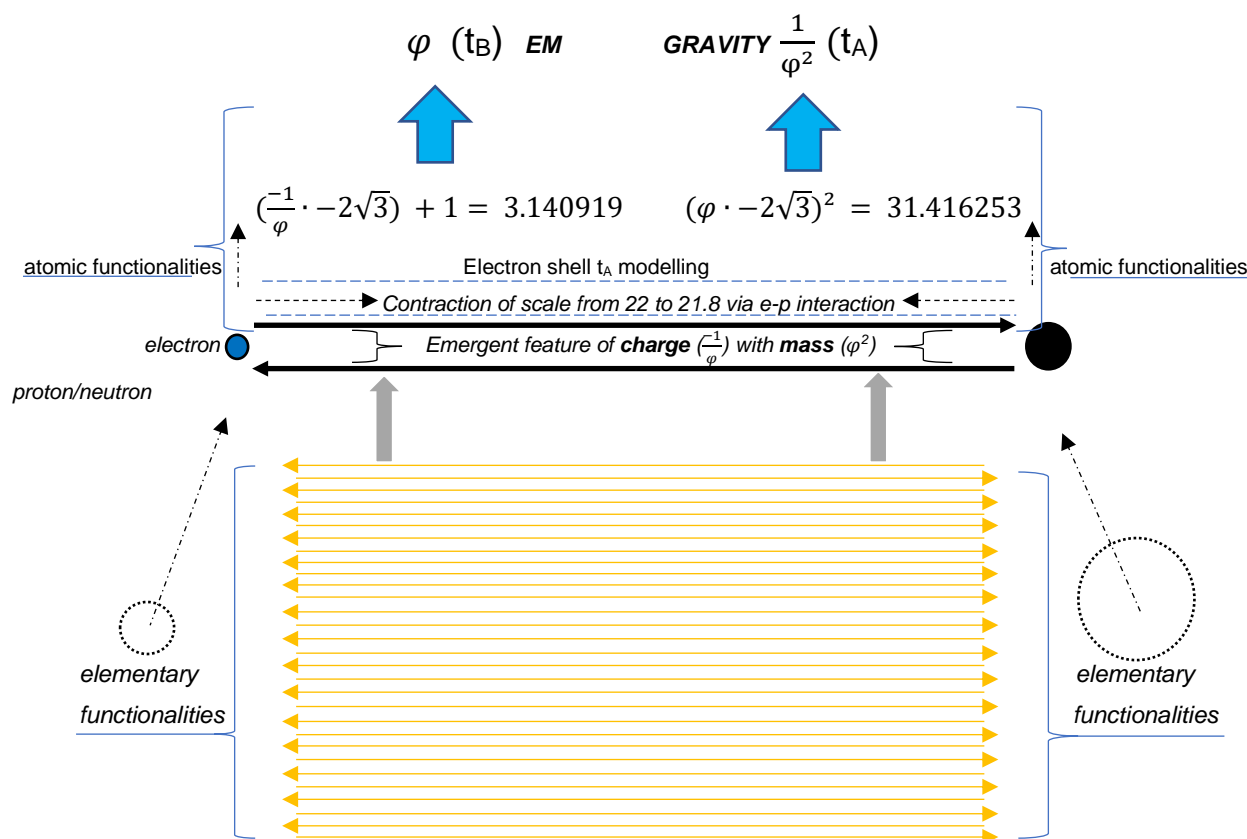

Figure 1; Note the emergence of time as t_B and t_A different to the manifestation in the phi-quantum wave-function.

Time though is an independent entity as t_B ; the idea of $\frac{1}{t_B^2}$ as $\frac{1}{\phi^2}$ is a potentiality of the future t_A . Simply, only “1” t_B event is upheld despite t_B forever considering a $\frac{1}{t_B^2}$ future for itself. We also know from paper 2 [2] that t_B as ϕ is the magnetic component ([2]; eq4), how time makes its presence as emerging from the atom, and that $\frac{-1}{\phi}$ is the electrical component that would be expressed as a resonance in t_A ([2]; eq6) as gravity. In other words, the electrical component of a reference of time (a quantum reference of a spatial event) would be in entanglement with another time reference somewhere, yet only one of the references can be defined via the passage of time as an independent reality in that golden ratio relationship process. Simply, if two events of time in space are in entanglement, they would need to have opposing golden ratio features when measured in the passage of time. And this we find as an experimental fact. But further to this, the entanglement explained here would need to represent an immediate event, because that’s what we’re allowing for time as a process of the arrow of time into the future. This is the almost immediate “spooky action at a distance”, and this theory for time explains it. Simply, the “emergence” of time as a $t_B(\frac{-1}{\phi})$ event that as a concept of space in time has “another” $t_B(\frac{-1}{\phi})$ reference that it is in quantum entanglement with, the electrical property itself, which would transcend the speed of light in being bound by the feature of $\frac{1}{t_B^2}$, of it would seem, “gravity”, suggesting gravity operates in an “immediate” fashion through space.

Is this a “probability” function? Is what we are explaining a “probability wave” as per the findings of the double slit-experiment? Of course, yet it is not a probability wave-function per-se, for the idea of a “probability” wave is a word we label something with which we’re not entirely sure about. Here we have more certainty about what exists on the path of a quantum travelling through space as energy, and why there exists relationships around

itself that assumes the form of an emergent feature of a phi-quantum wave-function and more importantly quantum-entanglement.

Something interesting happens though when considering a quantum entanglement construct entire. If one event is $\frac{-1}{\phi}$ then the other event would be as ϕ . Their combined event represents a value of -1 ($\phi \cdot \frac{-1}{\phi}$) as a t_A event, meaning that as a t_A event representing -1, the t_B event itself can only be represented as a complex number as per ([1]; eq3, p4). This is how we explained the “flow” of time; time essentially would be an imaginary number by this manner of regard, and thus the idea of a new spatial dimension of regard for time emerges, namely that the concept of entanglement creates an automatic immediate relationship that could be confused as creating two events in time as being the same thing. Time thus as energy would appear by this process of definition almost “beyond” the scope of itself as a concept of “time”, well, would have to be, if indeed time is a concept in entanglement with something, having a feature of itself beyond the simple arrow of time itself; “time” thus should be considered superseded by the concept of this furthered definition together with the idea of entanglement itself, and thus the mystery of the “immediate” nature of entanglement be better approached in this manner.

2.1.1 Paper 1 <specific dissection>:

([1]; p5): *Fundamentally, the value “i” for t_B would represent the idea of time as entropy remaining fixed on such a threshold of consideration. Note also the ratio of $\frac{t_N}{t_B}$ respective to time, a value of $\frac{1}{\phi}$ is an idea related to energy manifold reversal of black-holes [9] <a fundamental process of energy release and the flow of time beyond the cusp of a theoretical black-hole scenario>, which also provides an indication confirming “c” being a universal constant.*

It was then highlighted that integral to the flow of time as energy is a type of “negative-inversion” feature as per Maxwell’s equation for electromagnetic induction:

([1]; p8): *What we could appear to have here is the a process of electromagnetic induction itself, as a continual process of $t_N > t_A \sim t_N > t_A$, etc..., as a process of negative inversion, the flow kept in the t_N zone, as a process of constant flux as it moves into the t_A zone effecting a negative inversion in the t_N zone. Furthermore, magnetism would appear by this arrangement to be the process of the “anti-particle/mass”, but here as energy a process of negative-inversion of electrical field strength as a process of constant forward negative inverse feedback looping of time, without end it seems. Consider the following as Maxwell’s equation [10][11]:*

$$\nabla \cdot E = -\frac{\delta B}{\delta t}$$

This equation simply states that a change in electrical flow ($\nabla \cdot E$) in a solenoid induces a magnetic field that acts to oppose that change in electrical field ($-\delta B$) per change in time (δt). Another way of saying it is that the electrical energy ($\nabla \cdot E$) accumulated in a closed circuit is equivalent to the time rate of change (δt) of the magnetic flux it encloses ($-\delta B$). Note also the lower value of time (δt), the greater the electrical “induction” value, in that a shorter/more-rapid time results in greater electrical charge values ($\nabla \cdot E$).

This equation would hold true, as the chosen event outcome of quantum entanglement. The idea of energy shells took shape, as the concept of t_A , (thus t_B^2): the energy associated to this would be relevant to a type of electromagnetic induction, and thus proportional to $\frac{1}{t_A}$.

([1]; p12-13): *What of the actual t_A time front that energy “effects” into existence? We must bear in mind that the time-past (t_B) value of time (as imaginary time, see First Principles (2)) extends outwards along a spatial 3-d 0-scalar spatial matrix as a spherical front (fig. 9.1., 9.2., 9.3.). Therefore, on the atomic level, beyond the 0-scalar spatial reference away from which the time front moves as imaginary time, there would exist spherical fronts of this electromagnetic (as*

we know as “energy shells”) coupling from a light/atomic source that aligns with the golden ratio equation for time; this would extend outwards effecting charge and matter according to the equations we have generated (fig. 15.1., 15.2.) <not drawn to scale> as a basic model of the atom for t_N (fig. 15.2.).

([1]; p14): To calculate a process of atomic energy decay care of the electron changing energy states is also a different equation. We could say that the wavelength difference between t_{A2} and t_{A1} is a simple subtraction, yet it is not, as both t_{A1} and t_{A2} represent a code relevant to the golden ratio that has already happened, thus we must create a new point source of light for t_{A1} and t_{A2} with this new $t_{A2}-t_{A1}$ event (fig. 15.3.).

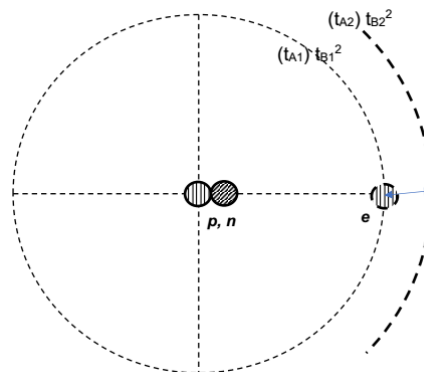

Figure 15.3.; both t_{A1} and t_{A2} represent a code relevant to the golden ratio that has already happened as a “past” event, thus we must create a new point source of light for t_{A1} and t_{A2} with this new $t_{A2}-t_{A1}$ event.

Simply, it would represent $t_{A2}-t_{A1}$ “per” a t_{A2} and t_{A1} event:

$$\frac{t_{A2} - t_{A1}}{t_{A2} \cdot t_{A1}}$$

Yet we need a standard t_B measurement of the circumference for a metric of time, as t_C^2 (fig. 9.3.), and thus here for this equation “per” a circumference squared. Thus:

$$\frac{1}{t_C^2} \cdot \frac{t_{A2} - t_{A1}}{t_{A2} \cdot t_{A1}}$$

However, this is inverted to become a t_N value (negative inversion, as a process of decay <release of energy>) as a chosen t_A event: $t_C^2 \cdot \frac{t_{A2} \cdot t_{A1}}{t_{A2} - t_{A1}}$.

Regarding universal modelling, we suggested the following:

([1]; p16-17): This theorised perceived expansion of the Universe (owing to the golden ratio time algorithm) would as “light” represent the key feature of light on the atomic level as the “inverse” of the frequency of a Compton wavelength $\frac{\lambda_e}{c} \sim 8.1 \cdot 10^{-19}$ s, yet “squared” (t_B^2), and thus a value of roughly 10^{-36} s (exactly $6.7 \cdot 10^{-37}$ s). The idea here is that with each oscillation of energy of the electron, there would be a squaring effect in play as a time-front into the future, which of course would suggest such a rate of expansion of space (as measured through the electromagnetic spectrum). Yet this is a theoretical value, as a t_A entity. Thus, without the benefit of understanding the golden ratio for time, we could calculate that the Universe’s peak expansion acceleration from electromagnetic ground-zero data occurs close to 10^{-36} s from an event horizon big bang event.

So, we can substantiate all the proposals of the first paper. We can do this using the phi-quantum wave-function logic of time seeking to trace a perfect circle.

2.1.2 Paper 2 <specific dissection>:

([2]; p19): Beyond this, as highlighted in the initial paper [1], the idea of time going from time-before t_B to time-after as t_B^2 indicates a forever expanding spatial matrix, which is in fact a feature of light, an "effect", or to be more precise, an "illusion" set upon space by light ([1]; p16-17) [24]. Once again, this theorized perceived expansion of the Universe (owing to the golden ratio time algorithm) would as "light" represent the key feature of light on the atomic level as the "inverse" of the frequency of a Compton wavelength ($\frac{\lambda_e}{c} \sim 8.1 \cdot 10^{-19}$ s), yet "squared" (t_B^2), and thus a value of roughly 10^{-36} s (exactly $6.7 \cdot 10^{-37}$ s). The idea here is that with each oscillation of energy of the electron, there would be a squaring effect in play as a time-front into the future, which of course would suggest such a rate of expansion of space (as measured through the electromagnetic spectrum). Yet this is a theoretical value, as a t_A entity. Thus, the "red-shift" [25] effect would be a key-part of that t_B^2 process; as light (as defined as time) appears to be expanding, it would have the "same" effect on space by our definitions here, and thus make us consider "space" is expanding ultimately in the farthest reaches of observation and calculation at an accelerating rate.

The proposed fractal topology of space and time beyond atoms as discussed in the initial paper ([1]; p15-16) would inherently require the balancing of all atoms, those atoms through their valence (electron shell) association into molecules, and so on, with the feature of t_B^2 incurred, across an infinite 0-scalar manifold in presuming 0-scalar space could exist anywhere. In not calibrating t_B^2 through vast distances, the effect "would" be like a big-bang of an atomic level of time, as regarding the energy of the golden ratio time determination, that has happened in every point in space at the same time. Confirmation of this possibility of atomic fractal displacement in our analysis of perceived neutron stars is that neutron stars as observed to our calculations do indeed have a distinct "magnetic" component [26], and thus as though a feature fractally sprung from the atomic to the universal, clearly suggesting a fractal connecting pattern at play. Yet that phenomena appears not fractal to every reference. Basically, the fractal topology of each reference in 0-scalar space would need to interact with each other reference, and thus only logically there could be no "one" beginning reference given the actual state of a standard atom. So, where would an ultimate reference come from, given that such is a clear drive of scientific thought for our need to find that event-archaic?

Thus, as with paper 1 [1], all the proposals in paper 2 [2] are upheld from paper 4's[4] results.

2.1.3 Paper 3 <specific dissection>:

Regarding paper 3 [3], many very new ideas are forwarded regarding consciousness and the π -function of energy which should be perhaps the topic of a philosophical discussion given the difficulty of proof entertained. Yet the purpose of that paper was to include consciousness in an overall grand theory of time and space, which would seem mandatory. The main message was consciousness is a part of a fine-tuning process, a need to perfect, to resolve, the inherent disparities of time in space. The important question is, "what is the behaviour of energy, how does this lead to consciousness, and does it suggest a particular universal/cosmic shape/agenda". And so, the idea of a "wheel of time" was proposed as the cosmic agenda, a gauge invariant space-time that ultimately seeks to create a perfect "time" wheel, forever repeating, "without beginning or end".

We *could* suggest in carrying the idea of a steady-state universe regarding cosmology that the stars as viewed from our reference would represent an ultimate region of energy release and decay; the idea of a time line as an arrow and entropy and this as a cosmic phenomenon of the stars as a relic of maximum entropy, maximum energy release with the illusion of gross expansion yet being nothing more than the phenomena of time itself which paradoxically must repeat itself in the form of a perfect circle, and it can relate this as temperature to the cosmic microwave background radiation as an associated feature of atoms of the new phi-quantum wave-function and associated electron/energy-shell dynamism, yet only if there is an inverse entropy effect in play. So the question beckons, "where is the energy created from (an issue we shall now address)"?

2.1.4 Paper 4 <specific dissection>:

Regarding paper 4 [4], much has been forwarded about the nature of how time emerges from the phi-quantum wave-function. What wasn't touched upon in the concluding stages of paper four [4] was the idea of temperature as energy.

We made the following suggestion:

([4]; p16-17): we can suggest the following:

$$\pi \text{ error gradient} = \frac{1}{N_A} \tag{9}$$

How though is this a function of "time"? As a function of time, the π error gradient would represent the value of t_A as t_B^2 "per" each increment of quanta, and in this case here an increment of 21.8 (extra-atomic "time-quantised" reference).

Thus, we could suggest the following:

$$\frac{t_A}{21.8} = \frac{1}{N_A} \tag{10}$$

Thus, as a representation of "time" as t_B , the following applies:

$$t_B = \sqrt{\frac{21.8}{N_A}} \tag{11}$$

This is a value of $\sqrt{\frac{21.8}{6.072 \cdot 10^{23}}}$ which equates to $5.99 \cdot 10^{-12}$ s. As a value of s^{-1} we have a value of $1.67 \cdot 10^{11} s^{-1}$, or as we know 167 GHz.

How is this value significant? Basically, regarding the error gradient there is an equal value of time that would account for a type of electromagnetic manifestation of time of the value of 167GHz. Is there any evidence of this in nature? This value is well within our findings for the cosmic microwave background radiation which peaks in intensity at 160 GHz.

There is still more significance to equations 10 and 11 from paper 4 [4]. We know that the emergence of time from the atom as t_B and t_A is an entropic process. We also know that $t_B^2 = t_A$. Thus, $t_A = \frac{21.8}{N_A}$ would hold true. Yet, we are proposing that the emergent feature of energy of t_A is carried by $\frac{1}{t_B^2}$, not t_B^2 . If $\frac{1}{t_B^2}$ is energy release, entropy, t_B^2 as t_A could only represent the inverse, energy storage, enthalpy, such that $\frac{1}{t_B^2} \cdot t_B^2 = 1$ (t_N), as what could only be a steady-state situation. Consider figure 2 (using Fig.1 template) that explains the enthalpic and entropic layers of the atom:

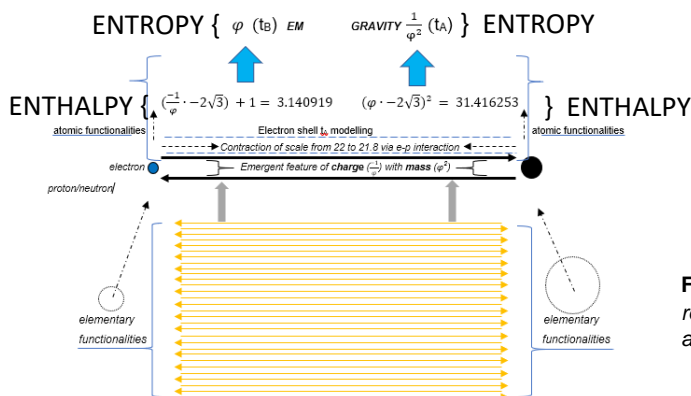

Figure 2: Note that t_B^2 as t_A would represent a feedback mechanism to the atom on this elementary particle scale.

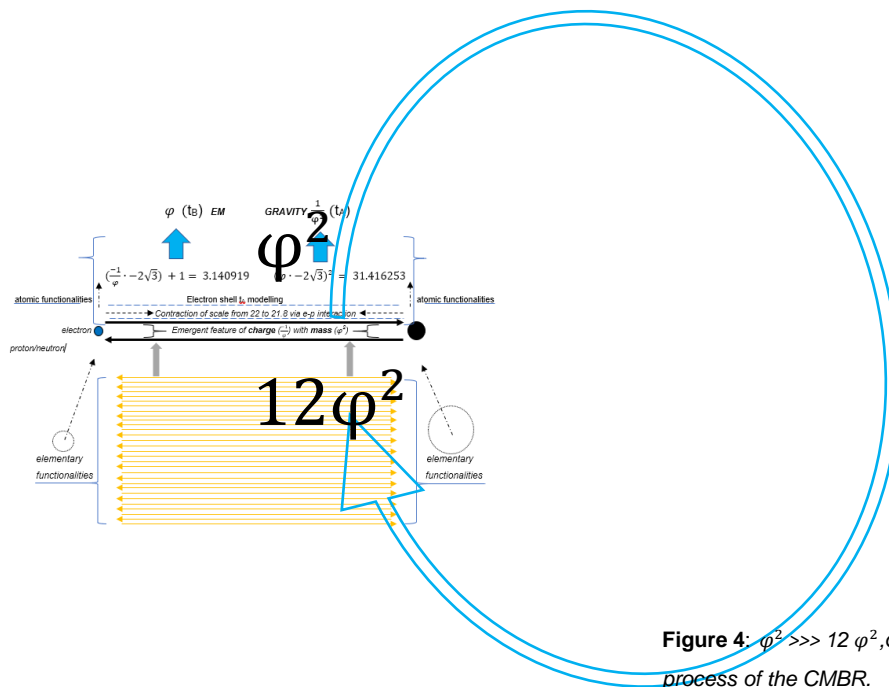

Figure 4: $\varphi^2 \gg 12 \varphi^2, \varphi^2 \gg (\varphi \cdot -2\sqrt{3})^2$, a process of the CMBR.

This process suggests that “time” emerging in “this” way in the form of the “steady-state”-adjusted heat (φ) would need to suffice a value of “ $12 \varphi^2$ ”, or more specifically would need to undertake “12” factors of the theorised π “time-wheel” to accommodate for the fundamental atomic $(\varphi \cdot -2\sqrt{3})^2$ manifold. How this occurs would dominate how the overall cosmos/universe is organised/shaped, dimensions included, as per the behaviour of gravity, how indeed that balance would be achieved in a steady state reality, a detailed concept that will be addressed in a later paper. One thing here to note is that there would be a basic platform of atomic matter together with an accessory platform that provides for the basic platform per this “12” factorial (required dimensions factored in). The suggestion here is that reality would be organised with a central atomic platform “around which” would be a cosmic platform providing for a central atomic platform per a “12”-factorial capture process such that “time” as energy would need to impart itself as φ^2 upon the general $12\varphi^2$ atomic manifold, and somehow undertake a 12-fold rise in value to link with the atomic enthalpic process. Consider figure 5 which proposes an “atomic” styled primary manifold (given fractal gauge invariance) for reality, which gives rise to the φ^2 CMBR, which would then logically feedback to a primary enthalpic $12\varphi^2$ atomic manifold.

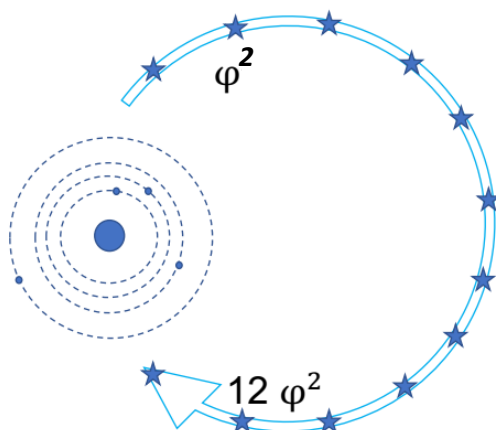

Figure 5: An atomic-styled platform (much like a solar system) with a “providing” CMBR.

Note that the “kelvin” value of this energy “end to beginning” process is only being considered here; the electron volt value of this “return” process for each atomic reference would refer to the amount of energy required to move an electron through a difference potential of 1 volt (and carries with it specific subatomic elementary particle contexts of use and thus meaning not deliberated on here owing to the different nature of inquiry and research). Thus, essentially on this universal atomic system manifold level, the highly complex nature of atoms and compounds would be reduced in the entropic process (exothermic reactions), imparting this fire/energy to the CMBR; atoms in releasing energy this way would become locked in with other atoms in the form of new reduced compounds and molecules, and this process would happen from a region of high complex atoms to low complex atoms. These compounds and molecules would ultimately form a massive structure of primarily heat release, a central ϕ manifold of time-space (like a sun), which as explained would need to impart energy to the $12\phi^2$ cosmic manifold region. The process would be one of the level of the atom continually adapting with other atoms to create a homeostasis with the system of time-space in the context of those general laws, ensuring that the shape of reality (the key topic of a subsequent paper, namely the logical identifiers of the ϕ^2 and $12\phi^2$ manifolds) would be maintained per the overall balance of laws for time-space, through merging with other atoms to release heat/energy. Moreover, in the context of the idea of consciousness emerging from chaos [3], from this entire process, consciousness would represent this energy process of the atomic $12\phi^2$ level seeking the CMBR ϕ^2 level, as the process of time perfecting π . And thus, the demise/disintegration of consciousness, would logically be the ϕ^2 construct/platform/manifold of time-space providing for the $12\phi^2$ time-space manifold. This will also be the subject of a subsequent paper, which will give an explanation to the general operation and shape of a $12\phi^2 > \phi^2$ (and vice-versa) time-space system, as a way to explain the redshift effect. The process of ϕ^2 returning to a $12\phi^2$ level as shall be highlighted in that paper is one of t_A utilising its primary “magnetic” level of $(\phi \cdot -2\sqrt{3}) + 1 = -4.605020$ ([2]: eq4), thus suggesting a primary “cosmic” magnetic feature on the very outskirts of our known time-space reality/manifold [10].

4. UNIVERSAL MIRROR

When light as time goes out so far, it would according to the logic become the idea of the golden ratio in its most basic form; this is the region where mass and thus gravity would “collapse”, disintegrate completely, per the general process of entropy. Here, the golden ratio would define two possibilities at right angles to each other as time ([2]; p4-5) representing an “ultimate reflection”, as a right-angle relationship of time in space, a light that (in the context of a sphere) logically feeds back on itself in the form of circular motion, like the basic structure of a swirling galaxy (Figure 6.).

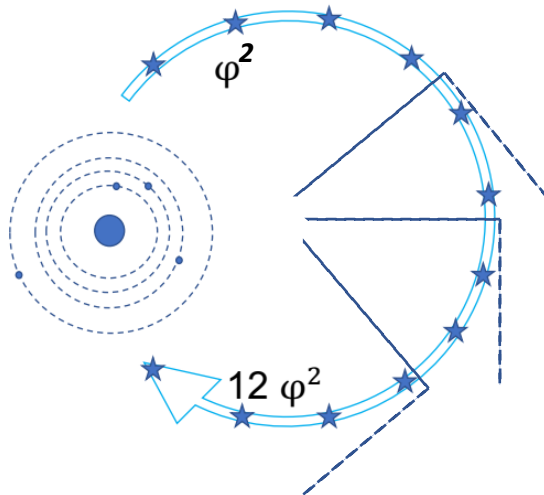

Figure 6: An atomic-styled solar-system platform with the CMBR from the entropic process of the sun reflected at right-angles in the stellar region, giving the effect of a "rotation" of light.

The proposed time-space "wall" is such, beyond which nothing would exist other than the image of a continued reflection of all that underlies its structure; the idea of a universal end-zone would be the concept of the golden ratio as time performing a right-angle to itself, not a perfect feedback upon itself, but a right-angle, creating the idea of an endless realm of pure empty space beyond. Within that endless realm of pure empty space would exist what the golden ratio as time can achieve with space through its various combinations of consideration. Note that where gravity collapses at such a vast distance, owing to the lack of physical/mass data, and that the pure primordial state of time only exists on such a primordial level of time and space, paradoxically as a "future" event, light would reflect along this golden ratio. The light reflected into the system therefore would take on the appearance of being channelled through what would appear to be an endless swirling golden-ratio (Fibonacci) swirling circular pipelines of stellar-atomic point activity, with each stellar-atomic point representing a type of binary feature of light/time as the golden-ratio right-angle displacement regarding space. This fits well with the first principals for time presented in paper 2 [2]. Note also that owing to this right-angle reflection, nothing is where it seems to be out there as a point of light, and thus the light of stars would wobble, suggesting the existence of planets around stars. Note also that the reflection at right angles would create a false location of the light that we would see as the stars. Overall, the manifold of this event of time and space would provide a massively complicated and seemingly "endless" (*such that for every cycle of the overall revolution of time there must be a replica of that event that never ends, in that if one cycle in time is complete, the intention with time would be to consider that the same concept must be ultimately replicated owing to the "reflection" concept of carried by the golden ratio for time*) array of points of light swirling light from that region.

The proposal of this general universal ring of time does sound absurd, as it completely simplifies the model of the universe to what would appear similar to the standard model circa 1600, yet there is evidence that the motion of the solar system and the orientation of the plane of the ecliptic are aligned with the phenomena of the CMBR. Research shows that the CMBR map demonstrates it is directly correlated with the plane of the earth around the sun, which suggests the source of the CMBR being the sun, as proposed here, suggesting not just a solar centric centre of the universe, yet that the stars could in fact be illusionary. Subsequently to the experimental results, the so-called "anomaly" has been dubbed the "axis of evil" (cosmological) [10] [11]. As incredulous as it would seem to modern cosmologists/astrophysicists, the theory here can only present what the logic of time and space organised in these papers deems "logical" in using the golden ratio as an algorithm for time, for it is what the theory here proposes, namely that the stars, when the filter and lensing effect of time is taken away (which itself would represent a type of never-ending "mirror" of light), are nothing more than particles and dust-clouds of atomic matter, nonetheless "fixed" in a steady-state time-space universal manifold, (if indeed time after time after time

(and so on) a type of recurring pattern must come into play); we have in this process taken care of the idea of the red-shift effect, the big bang, the cosmic microwave background radiation, and thus the obvious “lensing” and endless “reflecting” effect in play regarding stellar phenomena. Understandably, the only way we can know the true nature of the universe is to carefully test each of the models with actual exploration, most safely with probes. For instance, the Voyager 1 probe has confirmed a high magnetic pressure in the outer solar system region [12], a type of high magnetic pressure region pushing back in on the solar system, and the thinking here is that it is due to the $\varphi > 12\varphi^2$ effect. Nonetheless, we have achieved a “beginning to end” process for energy as time in a steady-state model. In a subsequent paper, we shall discuss the nature of gravity as an event horizon singularity using the logic of time as the golden ratio, and how such can be reproduced per experiment.

5. Conclusion

The key overall topic covered in this series of papers is the relationship between energy and time which explains the “arrow of time” with energy as the idea of entropy, yet ultimately as a steady-state space and time through the gauge invariance of a newly proposed wave-function of time that ultimately exists as a perfect circle in an imaginary/complex mathematical realm/plane, a type of fractal gauge invariance spatial-mass compression producing/creating energy in the form of the background microwave radiation and associated temperature effect leading to a steady state space and time reality. Central to this is the new phi-quantum wave-function incorporating strong and weak forces, electromagnetism and gravity, electron shells emerging the reality we perceive via this new wave-function, and how this is integral to electromagnetic induction on the t_A scale as an inverse negative function. Has any success been achieved, in noting that the goal of fundamental physics is to find the first principles from which all the fundamental dimensionless constants can be calculated and compared, as measured values? It’s all new theory using old evidence. Is there new evidence? How to find the new evidence shall be proposed in a subsequent paper regarding gravity as an event horizon singularity.

The question is often asked, “what would come first in a steady state universe, “consciousness”, or “chaos”, the “chicken or the egg” [13]”? The question is not when, but “what is sought” and “why”; the perfection of a circle, and thus the suggestion here as consciousness, would be the defining process, and not the chaos of energy per-se, obviously for anyone able to ask the question. Simply, it would be the process that matters most, because that is how the wave-function operates, seeking to perfect a circle, as though time as a complex number dimensional entity, is squeezed into existence in such a fashion by what we termed infinite “0-scalar” space ([2], p5-6). The idea of creation thus would be part of a role of consciousness repeating itself and fine-tuning itself towards that perfection, like on an eternal treadmill seeking the perfect order of time in the cosmos. This will be the subject of another subsequent paper, namely the role of consciousness with time and thus the golden ratio as a feature of logic; there, what will be addressed is the idea that using a theory that can explain basic atomic phenomena, yet a theory that isn’t proven to be the absolute truth, will always find evidence for that theory in the cosmos using a just as contrived mathematically constructed way of capturing data from the cosmos based on that theory that can explain basic atomic phenomena yet isn’t the absolute truth. It’s the adage of the wisdom of the snake chasing its tail, namely that we usually find what we’re looking for based on how we pursue the evidence. If we want evidence of a black hole based on a theory that wants to confirm black holes with ways of describing atomic phenomena that matches this description, we will find evidence for black holes given atomic phenomena “should” be represented in the cosmos. Yet how we arrived at the theory for black holes, namely based on the assumption that the cosmic microwave background radiation is evidence for a big bang, may in fact not be true. Similarly, “quantum mechanics” may be a good way to explain 90% of energy wave-functions, but it may not be 100%, especially if it can’t adequately explain the logic of quantum entanglement and the associated seemingly

illogical immediacy of time. Subsequently, therefore, in the absence of a complete theory, we could find ourselves, could have found ourselves, using alternative theories to explain phenomena that doesn't add up, theories such as Dark energy to explain inflation theory, and Dark matter to explain how the universe would appear to hold itself together, and of course the big bang theory to explain the red-shift effect and associated cosmic microwave background radiation. It should thus be mandatory for us to uncover the actual laboratory based generated evidence of any new theory, and in this case with these papers, gravity being able to emerge from electrodynamics, together with addressing the initial cause of logic our perception utilises to formulate theories of time and space.

Conflicts of Interest

The author declares no conflicts of interest; this has been an entirely self-funded independent project.

References

1. Jarvis S. H. (2017), *Gravity's Emergence from Electrodynamics*, <http://vixra.org/abs/1704.0169>, www.gravielectric.com.
2. Jarvis S. H. (2017), *Golden Ratio Axioms of Time and Space*, <http://vixra.org/abs/1706.0488>, www.gravielectric.com.
3. Jarvis S. H. (2017), *The Emergence of Consciousness from Chaos*, <http://vixra.org/abs/1707.0044>, www.gravielectric.com
4. Jarvis S. H. (2017), *Phi-Quantum Wave-Function Crystal Dynamics*, <http://vixra.org/abs/1707.0352>, www.gravielectric.com
5. Schrödinger E (1935). "Discussion of probability relations between separated systems". *Mathematical Proceedings of the Cambridge Philosophical Society*. **31** (4): 555–563. [Bibcode:1935PCPS...31..555S](#). [doi:10.1017/S0305004100013554](#).
6. Penzias, A. A.; Wilson, R. W. (1965). "A Measurement of Excess Antenna Temperature at 4080 Mc/s". *The Astrophysical Journal*. **142** (1): 419–421. [Bibcode:1965ApJ...142..419P](#). [doi:10.1086/148307](#)
7. Yang C. N., Mills R. L. (1954). "Conservation of Isotopic Spin and Isotopic Gauge Invariance". *Phys. Rev.* **96**: 191–195. [Bibcode:1954PhRv...96..191Y](#). [doi:10.1103/PhysRev.96.191](#)
8. Steven Weinberg. *Dreams of a Final Theory: The Scientist's Search for the Ultimate Laws of Nature*. Knopf Doubleday Publishing Group. ISBN 978-0-307-78786-6.
9. "CODATA Value: molar gas constant". The NIST Reference on Constants, Units, and Uncertainty. US [National Institute of Standards and Technology](#). June 2015. Retrieved 2015-09-25. 2014 CODATA recommended values
10. Anthony Challinor (2012). "CMB anisotropy science: A review". *Proceedings of the International Astronomical Union*. **8**: 42–52. [arXiv:1210.6008v1 \[astro-ph.CO\]](#). [doi:10.1017/S1743921312016663](#).
11. Land, Kate; João Magueijo, João (2005). "Examination of Evidence for a Preferred Axis in the Cosmic Radiation Anisotropy". *Physical Review Letters*. **95** (7): 071301. [arXiv:astro-ph/0502237](#). [Bibcode:2005PhRvL..95g1301L](#). https://www.nasa.gov/mission_pgces/voyager/multimedia/burlaga3.html, webpage accessed 16th Dec. 2017.
13. Sorensen, Roy (2003). *A Brief History of the Paradox: Philosophy and the Labyrinths of the Mind*. Oxford: Oxford University Press. pp. 4–11.