

The misuse of the No-communication Theorem by Ghirardi - In the analysis of a Non-local Communication System That effectively swaps distant joint entanglement to Local path entanglement of an interferometer

Remi Cornwall

University of London Alumni Society, Malet Street, London WC1E 7HU
http://webspaces.qmul.ac.uk/rocornwall http://www.researchgate.net/profile/Remi_Cornwall

Abstract

This paper is in response to a critique of the author's earlier papers on the matter of a non-local communication system by Ghirardi. The setup has merit for not apparently falling for the usual pitfalls of putative communication schemes, as espoused by the No-communication theorem (NCT) - that of non-factorisability. The enquiry occurred from the investigation of two interferometer based communication systems: one two-photon entanglement, the other single-photon path entanglement. Both systems have two parties: a sender ("Alice") who transmits or absorbs her particle and a receiver ("Bob") who has an interferometer, which can discern a pure or mixed state, ahead of his detector. Ghirardi used the density matrix and found that the system wasn't factorisable; this was seen as a fulfilment of the NCT. We revisit the analysis and say quite simply that Ghirardi is mistaken. The system is rendered factorisable by a Schmidt decomposition and entanglement swapping to "which path information" of the interferometer. Ghirardi's misuse, by the inapplicability of the NCT in this situation, renders this general prohibitive bar incomplete or entirely wrong.

1. Introduction

This discussion takes place in the arena of the supposed limitation against communication by remote quantum state collapse by the No-communication theorem[1, 2]. The author investigated two schemes using entangled communication[3, 4] (figures in the appendices 1 and 2) and is currently seeking partners to corroborate either method.

Referencing the first figure (appendix 1), a source of polarisation entangled photons is equidistant between a transmission gate ("Alice"), who intends to transmit a classical binary protocol by: either letting her photon through the gate (binary 0) or by absorbing it (binary 1). A detector, at just greater than the distance the left-hand gate is from the source of photons on the right-hand side, is at the output of an essentially Mach-Zehnder interferometer. The interferometer has a polarising beam-splitter that is able to form two arms in the horizontal and vertical basis. These two arms are then rotated to the diagonal by Faraday rotators by $\pi/4$ radians (one could be used of $\pi/2$ radians but two are shown) and interfere at the right hand detector ("Bob"). We shall see later that Schmidt decomposition has occurred and that entanglement of the source has been swapped to local path entanglement in the right hand interferometer. Bob is able to discern whether Alice has measured her photon or not by discerning the pure state of entanglement or the mixed state after measurement.

Another method (appendix 2) uses one single photon source and a conventional Mach-Zehnder interferometer to generate path entanglement. This is in direct analogue to the entangled two photon system shared between Alice and Bob in appendix 1; in appendix 2 they share a path entangled system. The subtle difference here is that Bob has no interferometer, but as appendix 1, he only has to interfere the two coherent (or incoherent) arms. In a way, much of the interferometer is subsumed into the source and the figure in appendix 1 could have been drawn this way. To repeat, Bob only interferes the two arms from the interferometer.

Mathematically the entangled polarised two-photon system is similar to the one photon path-entangled system, as both are forms of the Bell states[5].

$$\begin{aligned} |\Phi^\pm\rangle &= \frac{1}{\sqrt{2}}|H_1\rangle|H_2\rangle \pm \frac{1}{\sqrt{2}}|V_1\rangle|V_2\rangle \\ |\Psi^\pm\rangle &= \frac{1}{\sqrt{2}}|H_1\rangle|V_2\rangle \pm \frac{1}{\sqrt{2}}|V_1\rangle|H_2\rangle \end{aligned} \quad \text{eqn. 1}$$

One only has to enumerate the states above into the computational basis to see the similarity with path entanglement (especially the $|\Psi^\pm\rangle$ state for one particle path entanglement), even though the Hilbert space dimension is larger for the two-photon system:

$$\begin{aligned} |\Phi^\pm\rangle &= \frac{1}{\sqrt{2}}|0\rangle|0\rangle \pm \frac{1}{\sqrt{2}}|1\rangle|1\rangle \\ |\Psi^\pm\rangle &= \frac{1}{\sqrt{2}}|0\rangle|1\rangle \pm \frac{1}{\sqrt{2}}|1\rangle|0\rangle \end{aligned} \quad \text{eqn. 2}$$

The author has directly interacted with two of the founders of the No-communications theorem (NCT), Michael Hall (Australian patent office, whom granted a patent) and Giancarlo Ghirardi, whom offered a repost[6]. In this note, Ghirardi used the density matrix treatment. We seek to counter those arguments coherently and concisely.

2. Analysis of the two-photon setup

We are interested (appendix 1) in two endpoints of communication, so the joint evolution of a two particle system is used. The state vector formalism gives this as:

$$|\psi_1\rangle \otimes |\psi_2\rangle = O_1 |\psi_1\rangle \otimes O_2 |\psi_2\rangle \quad \text{eqn. 3}$$

Where the operators O_1 and O_2 (which themselves may be several operators) act on their respective quantum states, be they unitary or non-unitary. The ensuing bone of contention, as we shall see, arises when the states can't be factorised and we shall discuss the first apparatus[3]/appendix 1 in this context. The evolution (not writing explicitly the tensor product symbol) is then:

$$|\psi_{12}\rangle = O_1 O_2 |\psi_{12}\rangle \quad \text{eqn. 4}$$

For the first apparatus[3], if the input is:

$$\psi_{12} = \frac{1}{\sqrt{2}}(|H_1\rangle \otimes |V_2\rangle + |V_1\rangle \otimes |H_2\rangle) \quad \text{eqn. 5}$$

Then the evolution is: $|\psi_{12'}\rangle = O_1 O_2 |\psi_{12}\rangle$

$$|\psi_{12'}\rangle = \frac{1}{\sqrt{2}} \begin{pmatrix} \hat{U}_1 |H_1\rangle \otimes e^{-i\theta} e^{-i\frac{\pi}{4}} \hat{U}_{PBS} |V_2\rangle \\ + \hat{U}_1 |V_1\rangle \otimes e^{+i\frac{\pi}{4}} \hat{U}_{PBS} |H_2\rangle \end{pmatrix} \quad \text{eqn. 6}$$

Where,

- The first photon travels through free space: \hat{U}_1 (Unitary operation)
- The polarising beam-splitter is the projection: $\hat{U}_{PBS} = |H_2\rangle\langle H_2| + |V_2\rangle\langle V_2|$. Overall, considering the two arms, this operation is unitary too.
- The Faraday rotators (there can be just one with angle $\pi/2$) are shown: $e^{-i\frac{\pi}{4}}$ and $e^{+i\frac{\pi}{4}}$
- Then the phase plate to adjust the interference fringe is: $e^{-i\theta}$

The two arms of the interferometer are brought together and interfered. **Before measurement**, the state is:

$$|\psi_{12'}\rangle = \frac{1}{\sqrt{2}} (|H_1\rangle \otimes e^{-i\theta} |D_2\rangle + |V_1\rangle \otimes |D_2\rangle) \quad \text{eqn. 7}$$

Or

$$\rho_{12'} = \frac{1}{2} (|H_1\rangle + |V_1\rangle) |D_2\rangle \langle D_2| (\langle V_1| + \langle H_1|) \quad \text{eqn. 8}$$

Where D represents the diagonal basis and the arbitrary global phase on system 1 has been ignored. The system is now factorisable and the polarisation entanglement has been swapped to path entanglement. One final operation gives the effect of the detector by the number operator $\hat{n}_2 = \hat{a}_2^\dagger \hat{a}_2$ projecting into the number basis:

$$\begin{aligned} |\psi_{12''}\rangle &= \hat{U}_1 \hat{n}_2 |\psi_{12'}\rangle \\ \Rightarrow \\ |\psi_{12''}\rangle &= \hat{U}_1 |\psi_{1'}\rangle \otimes \frac{1}{\sqrt{2}} (1 - e^{-i\theta}) |1_2\rangle \end{aligned} \quad \text{eqn. 9}$$

Or

$$\begin{aligned} \rho_{12''} &= \frac{1}{2} (1 - e^{-i\theta}) |\psi_{1'}\rangle |1_2\rangle \langle 1_2| \langle \psi_{1'}| (1 - e^{+i\theta}) \\ &= (1 - \cos \theta) |\psi_{1'}\rangle |1_2\rangle \langle 1_2| \langle \psi_{1'}| \end{aligned} \quad \text{eqn. 10}$$

It is easy to then trace out system one by a **Schmidt decomposition**[5] to see system two:

(Before measurement)

$$|\psi_{2''}\rangle = \frac{1}{\sqrt{2}} (1 - e^{-i\theta}) |1_2\rangle \quad \text{eqn. 11}$$

Or

$$\rho_{2''} = (1 - \cos \theta) |1_2\rangle \langle 1_2| \quad \text{eqn. 12}$$

Measurement on either system and the spectral theory yields the mixed state:

$$\begin{aligned} |\psi_{12}''\rangle &= \frac{e^{-iRand}}{\sqrt{2}} (|H_1\rangle \otimes e^{-i\theta} |1_2\rangle) \\ \text{or } & \frac{e^{-iRand}}{\sqrt{2}} (|V_1\rangle \otimes |1_2\rangle) \end{aligned} \quad \text{eqn. 13}$$

$$\begin{aligned} \rho_{12''} &= \frac{1}{2} |H_1\rangle |1_2\rangle \langle 1_2| \langle H_1| \\ &+ \frac{1}{2} |V_1\rangle |1_2\rangle \langle 1_2| \langle V_1| \end{aligned} \quad \text{eqn. 14}$$

We go straight to the number basis, rather than show the detector step. The factor, e^{-iRand} is the random phase relation between the arms of the interferometer resulting from measurement upon the system; on the time scale of measurement it is easy to show[4] that this would lead to the density eqn. 14, the off-diagonals would effectively be zero. The trace out yields (the phase of individual events is not important nor is there superposition) at the detector:

(After measurement by Alice)

$$|\psi_{2''}\rangle = \frac{1}{\sqrt{2}} |1_2\rangle \quad \text{eqn. 15}$$

Or

$$\rho_{2''} = \frac{1}{2} |1_2\rangle \langle 1_2| \quad \text{eqn. 16}$$

3. One-photon system

Analysis of the one-photon system (appendix 2) is similar; as mentioned before, this has very similar mathematics (eqn. 1 and eqn. 2) if the zero particle state is viewed as an entangled particle. This is covered in a previous publication[4].

More disturbingly, it can be analysed by **one particle** quantum mechanics (graphic insert appendix 2) and leads to the same conclusion. This ought to be alerting the reader to the fact that the NCT, the machinery of it and the crux of the argument – taking the partial trace, are not relevant – what system is there to trace out?

4. An erroneous belief about evolution and the partial trace and a crucial step in the overall argument

For a long time, simple entangled communications schemes, such as projecting entanglement polarisation with a polarising filter into a supposed state, have been shot down. The physical reason is that measurement leads to a random collapse into the projected state and we simply obtain a noise channel. Mathematically this was codified into the notion, that isolating a system requires the partial trace to be taken – it leads to the mixed state.

This *mathematical operation* of taking the partial trace, as part of the NCT, has been taken too literally by several academics to whom the author has been in correspondence. To them, *even just considering* one system would result in the mixed state; the implication was that joint evolution was not even possible and further discussion was not warranted! To them, the mantra is repeated, “Any form of entanglement communication is prohibited because the partial trace must be taken”. This trite summation of the NCT is a misunderstanding of its sentiments.

This notion of not even being able to consider the joint evolution is easy to dispel: consider a source of entangled particles – how can they even travel through free space (a unitary transform)? If only one particle’s unitary evolution is considered the system is still entangled, otherwise entanglement wouldn’t exist as a phenomenon if it was decohered so easily, just from travelling in free space.

What is really being misunderstood by the research community is that the partial trace is synonymous with a non-unitary evolution, i.e. a measurement. If we trace out a particle from a joint wavefunction thus:

$$\rho'_2 = \text{tr}_1(U_{12}\rho_{12}U_{12}^\dagger) \quad \text{eqn. 17}$$

The partial trace is exactly synonymous with the spectral decomposition of measurement, which is a non-unitary operation:

$$\langle M_2^\dagger M_2 \rangle = \text{tr}(M_2 |\psi\rangle\langle\psi| M_2^\dagger) = \text{tr}(\rho_2 M_2^\dagger M_2)$$

Because the partial trace when “distributed” into the joint evolution U_{12} even if it was unitary, renders the operator acting on system non-unitary.

Having established that the joint evolution can be taken is a crucial step in our argument: individual operations can be taken on one subsystem to swap the joint entanglement to local path entanglement, as was seen with the interferometer arrangements of the figures in the appendices.

5. Conclusion

The No-communication theorem since its inception has been extensively cited. The simple and obviously correct proof herein shows a glaring flaw in its application regarding a system that maintains entanglement information, by swapping joint entanglement to local path entanglement and performing a Schmidt decomposition, which renders the system factorisable. The **NCT only applies to non-factorisable systems** and the slavish, unthinking citing of it must cease.

Single particle path-entanglement experiments alone[4], without all the machinery of multi-particle quantum systems, show obvious known experimental fact; yet if one transforms it into a two particle system by considering the vacuum state as a quasi-particle and uses the incorrectly applied rationale of the NCT, we arrive at a result not just in abeyance of experimental fact *but also* in abeyance of the treatment for a single particle system too. This is a ridiculous situation.

References

1. Ghirardi, G.C.; Grassi, R.; Rimini, A.; Weber, T., *A General Argument against Superluminal Transmission through the Quantum Mechanical Measurement Process*. Lettere al Nuovo Cimento, 1980, 8th March. **27**(10): p. 293-298.
2. Hall, M.J.W., *Imprecise Measurements and Non-Localty in Quantum Mechanics*. Physics Letters A, 1987. **125**(2,3): p. 89,91.
3. Cornwall, R.O., *Secure Quantum Communication and Superluminal Signalling on the Bell Channel*. Infinite Energy, 2006. **69** (<http://vixra.org/abs/1311.0074>).
4. Cornwall, R.O., *Superluminal Signalling by Path Entanglement*. 2015 (<http://vixra.org/abs/1410.0113>).
5. Nielsen, M.C.; Chuang, I., *Quantum Computation and Quantum Information*. 2000: Cambridge.
6. Ghirardi, G., *Comments on a recent proposal of superluminal communication*. 2014 (<http://arxiv.org/pdf/1411.0893.pdf>).

I thank all, Professor Francois Leyvraz, Department of Physics, Universidad Nacional Autónoma de México, Professor Kåre Olaussen, Department of Physics, Norwegian University of Science and Technology and Professor John O’Rarity/Dr Eliahu Cohen, Department of Photonics/Department of Physics, Bristol University and Professor Avshalom Elitzur, Unit of Interdisciplinary Studies, Bar-Ilan University, Israel, Professors Emeritus Jack Sarfatti and Nick Herbert, for their proof-reading, criticisms, suggestions and praise their grace under fire with this researcher.

I thank too Queen Mary, University of London for the general use of its facilities and the support of Richard Edwin Balding’s funding of my research.

Appendix 1 – Two H-V entangled photon communication scheme

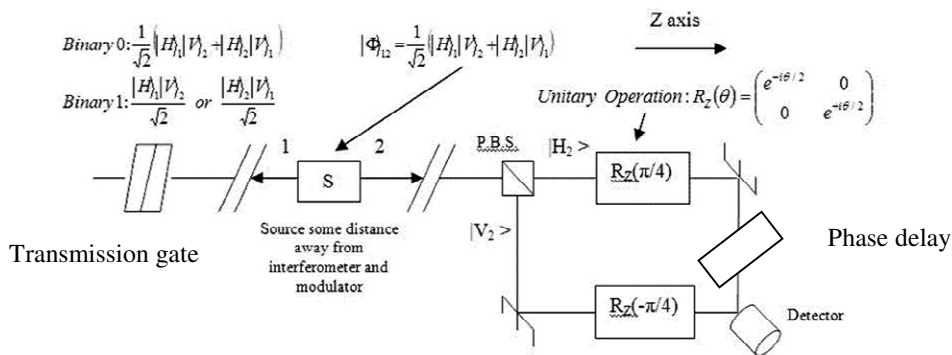

Measurement/Modulation at distant system and state of two photon system	State of distant system	State of local system	Local measurement by interferometer after modulation of distant system
No modulation: 'Binary 0' $\frac{1}{\sqrt{2}}(H_1\rangle V_2\rangle + H_2\rangle V_1\rangle)$	Entangled => Pure state $\frac{1}{\sqrt{2}}(H_1\rangle + V_1\rangle)$ Behaves as, see Appendix 1: arxiv.org/abs/1106.2258	Entangled => Pure state $\frac{1}{\sqrt{2}}(V_2\rangle + H_2\rangle)$ Behaves as, see Appendix 1: arxiv.org/abs/1106.2258	Pure state results in interference (Or at least some interference since source is not ideally pure)
Modulation: 'Binary 1' $\frac{ H_1\rangle V_2\rangle}{\sqrt{2}}$ or $\frac{ H_2\rangle V_1\rangle}{\sqrt{2}}$	Not entangled <=> $\frac{ H_1\rangle}{\sqrt{2}}$ or $\frac{ V_1\rangle}{\sqrt{2}}$ Mixed state	Not entangled <=> $\frac{ H_2\rangle}{\sqrt{2}}$ or $\frac{ V_2\rangle}{\sqrt{2}}$ Mixed state	Mixed state gives no interference

Appendix 2 – Single photon path entangled communication scheme

Single photon source (SPS) incident on Mach-Zehnder type interferometer with 50:50 beamsplitters. Alice's measurements discerned over space-like separations by Bob at his detectors C (constructive) or D (destructive)

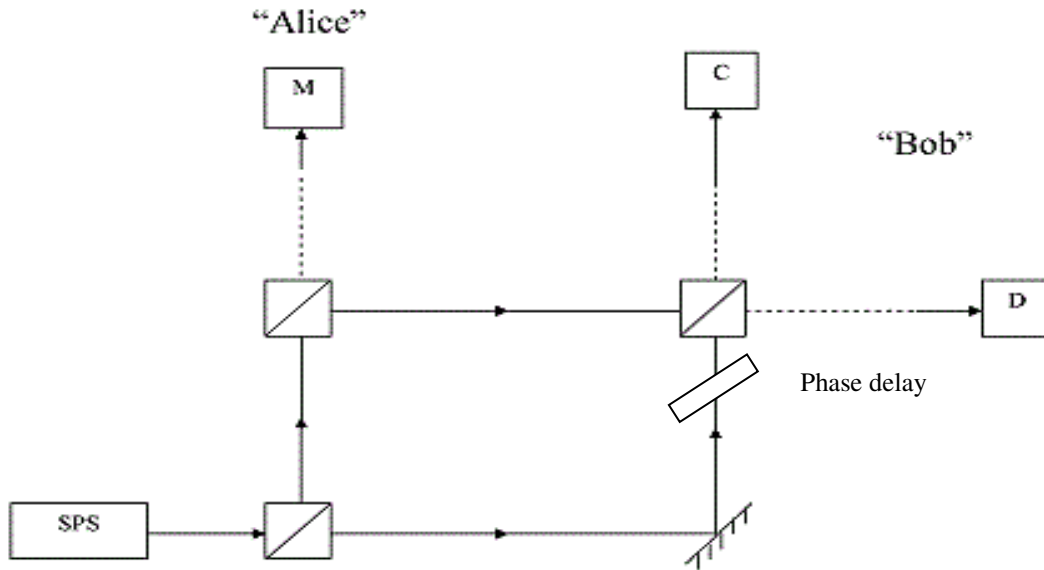

Alice	Bob
0: No measurement	No signal, destructive interference from pure state
1: Measurement	Signal from mixed state

$$P(\text{Measurement, bit 1}) = \left| \frac{i}{\sqrt{2}} \right|^2 + \left| \frac{i}{\sqrt{4}} \right|^2$$

$$= 0.5 + 0.25$$

$$= 0.75$$

$$P(\text{No-measurement, bit 0}) = \left| \frac{i}{\sqrt{2}} \right|^2 + \left| \frac{e^{i\theta}}{\sqrt{4}} \right|^2 + 2 \left| \frac{i}{\sqrt{2}} \right| \left| \frac{e^{i\theta}}{\sqrt{4}} \right| \cos(\arg \theta)$$

$$= 0.5 + 0.25 + \frac{1}{\sqrt{2}} \cos(\arg \theta)$$

$$= 0.75 \pm 0.707 \cos(\arg \theta)$$

$$= 0.043 \text{ minimum}$$