

# Smart Systems for Road Traffic Congestion Detection and Control

Tannistha Pal<sup>1\*</sup>, Farhan Hai Khan<sup>2</sup>, Uttaran Chaudhuri<sup>1</sup>, Tiyasa Kundu<sup>1</sup>

1. *Department of Electronics and Communications Engineering, Institute of Engineering & Management, Kolkata, India.*

2. *Department of Electrical Engineering, Institute of Engineering & Management, Kolkata, India.*

\*Corresponding Author- [paltannistha@gmail.com](mailto:paltannistha@gmail.com)

## Abstract:

By the dusk of the 21st century, both developed & developing countries will witness a tremendous rise in automobile sales. Everybody will want to travel as fast as possible and reduce traffic waiting time. The objective of this research is to provide efficient algorithms and sound scientific principles for accurate traffic density estimations even in the busiest traffic hours. The methodologies discussed in this paper include the use of Infrared, Ultrasonic, Pressure & Piezoelectric sensors, and also Inductive loop detectors. These methodologies are further used to control real-time traffic lighting systems based on threshold-based decision algorithms. Further, Digital Image Processing techniques are analyzed which involve camera installation for congestion assessment and traffic control. Therefore, proper application of these methodologies will lead to early traffic detection with immediate disaster preventive measures that will ensure better passage for vehicles.

**Keywords:** Traffic Control Algorithms, Sensor Technologies, Traffic Density Estimation, Traffic Congestion, Traffic Waiting Time

## 1. Introduction:

Travelling has turned out to be a profoundly hectic activity in today's world with the uncontrolled population growth. The rise of travelers at every nook and corner of the city has caused drastic growth in traffic. Nowadays, traffic congestion is a common problem that has arisen over the years due to the increased number of vehicles on the road. This, in turn, has had negative impacts including road accidents, air pollution, wastage of precious fuel, and most importantly, unnecessary delays. One of the main causes of traffic congestion is an improper traffic management system.

The world's first traffic light was a manually operated gas-lit signal, invented in London in the 1860s to control traffic caused by horse carriages. But it exploded within a month injuring its policeman operator. Then in the early 1900s, the electric traffic light was invented and later it was replaced by automated traffic control systems. This system functions like a clockwork. A numerical value is loaded in the timer for each phase. Depending on changes in timer, light is set at ON and OFF states at regular intervals. But this system has a major flaw: often vehicles face unnecessarily lengthy waiting periods as the signal is red even when the opposite lane is empty.

But, in today's world, where technology has transcended all the barriers, it's easy to solve most of the human problems. The main purpose of this research is to propose different methodologies with their advantages and disadvantages to deal with traffic congestion problems. We can implement a density based traffic control system using sensors embedded under pavements or use image processing techniques over satellite navigation and CCTV cameras. Another approach to detect vehicles on the road and to control traffic lights is the use of pressure/ piezoelectric transducers to approximate vehicle weight, which in turn gives us the traffic density estimation of that road segment. The primary objective is to enable the smooth movement of vehicles by reducing the unnecessary waiting time by designing intelligent traffic control systems.

## 2. Traffic Density Estimation:

We broadly classify the Traffic Density into two types:

- (i) Internal Traffic Density
- (ii) External Traffic Density

Let  $I_m(t)$  denote the Internal Traffic Density. Physically this denotes the current traffic of the road segment  $m$ . This can be quantified using various methodologies, some of them being thoroughly analyzed in this research study are sensor technologies and image processing methods.

On the other hand, External Traffic Density quantifies the approximate incoming traffic in the immediate future and is the mean sum of the neighboring road segments. Mathematically it can be denoted by,

$$E_m(t) = \sum_{\forall k \in A} \frac{I_k(t)}{n(A)}$$

where,

- $E$  is the (Instantaneous) External Traffic Density Estimation at a given time  $t$ ,
- $m$  is the segment for which the traffic has to be calculated,
- $A$  is the subset of road segments that is adjacent to segment, &
- $n(A)$  is the cardinality ( number of elements ) in set  $A$ .

In simple terminology, we define the external traffic density estimation for the current road segment as the average sum of the adjacent road network's traffic density.

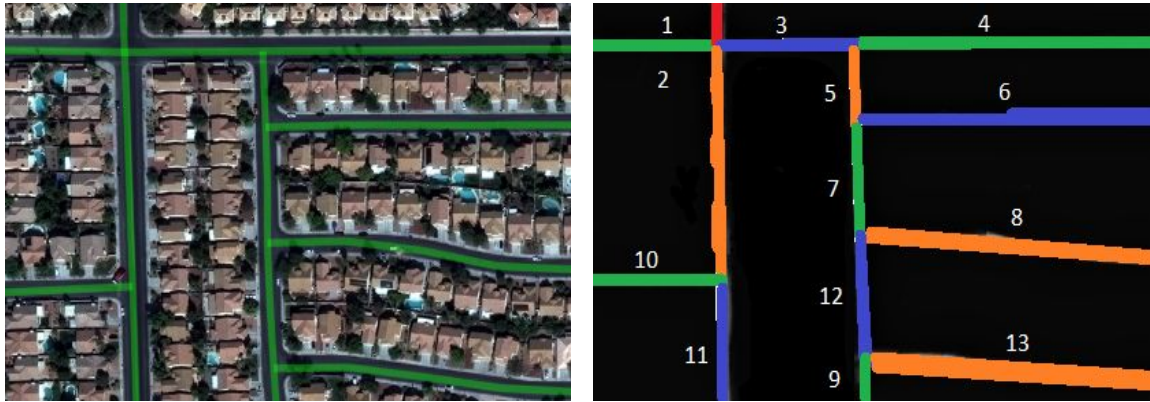

**Fig. 1:** Satellite Image from Las Vegas: Labelled Road Segmentation with Unique Numberings.<sup>[1]</sup>

For example, our equation states that the external traffic for road segment 7 is the cumulative sum of the traffic of its adjacent segments (8, 12, 5,6) divided by the number of adjacent road segments. Mathematically,

$$E_7(t) = \frac{[I_8(t) + I_{12}(t) + I_5(t) + I_6(t)]}{4}$$

The Actual Traffic Density Estimation (D) can be thought of as a linear combination of the Internal & External Traffic Density, mathematically,

$$D_m(t) = \alpha * E_m(t) + (1 - \alpha) * I_m(t)$$

The dilation factor, alpha belongs to [0, 1] and can be used to describe the nature of the influence of the current and the incoming traffic density.

### 3. Sensor Technologies:

#### 3.1. IR Sensor Approach:

This system is an automated density based traffic control system. The time period of traffic lights is assigned based upon traffic density present at that time. This is achieved by using Infrared Sensors<sup>[2]</sup>(IR Sensors). In the entire intersecting lane, IR sensors are positioned at fixed distances from the signal placed at the junction. These sensors are present on sides of the road, detect and count the number of vehicles present on the road to measure the traffic density. Once the traffic density is calculated, this information is sent to the microcontroller (Arduino/Raspberry Pi) and according to the IR count, it decides which road should be given the highest priority and the longest time delay for the corresponding traffic light.<sup>[3]</sup>

## Block Diagram of Density based Traffic Control System using IR Sensor

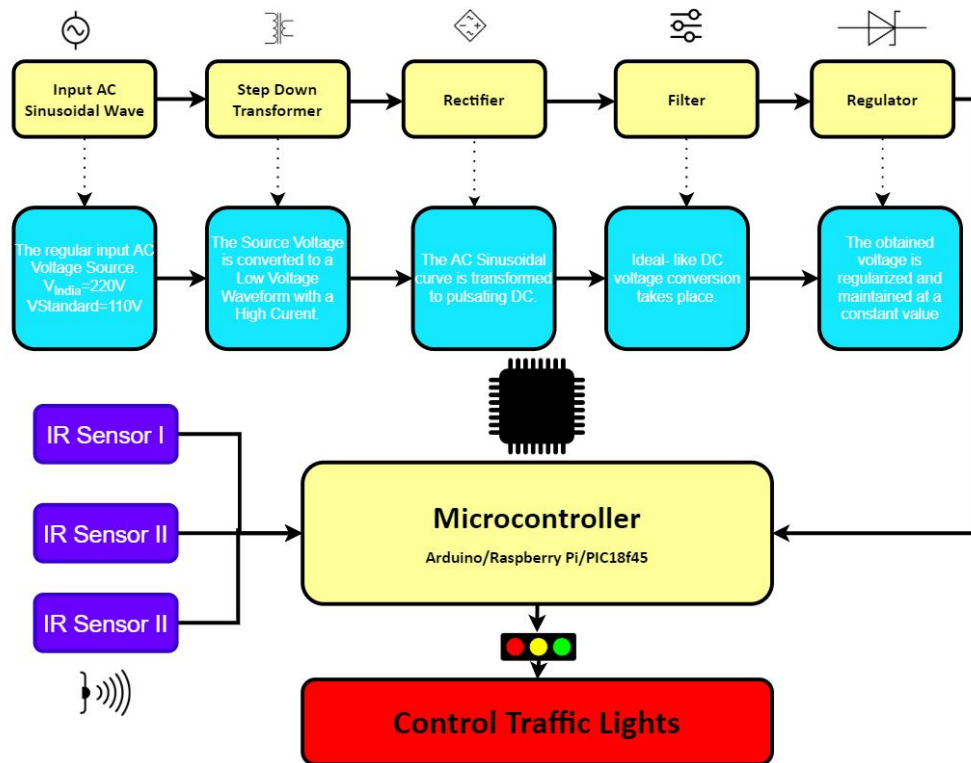

**Fig. 2:** Block Diagram of Density-based on Traffic Control System using IR Sensor: After initial voltage signal preprocessing, the Microcontroller ultimately shifts the signal for the Traffic Lights.

### 3.2. Ultrasonic Sensor Approach:

Ultrasonic sensors transmit sound waves at frequencies between 25 and 50 kHz (too high than audible sounds towards the target object.<sup>[3]</sup> Then it waits for the sound wave to be reflected. The received energy is converted into electrical energy which is sent to the processing unit. An Arduino board is used here as the processor. Then it calculates the distance based on the time required. This distance will tell us if any vehicle is near the signal or not and according to that, the traffic signals will be controlled<sup>[4]</sup>.

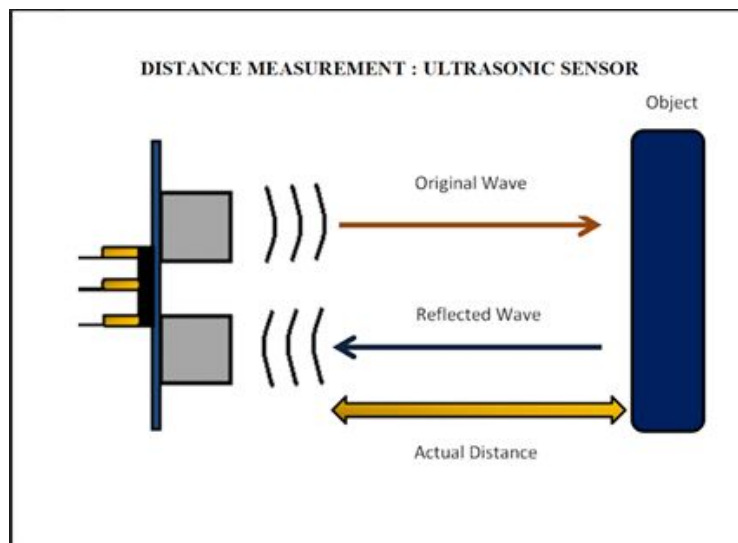

**Fig. 3:** Distance Measurement using Ultrasonic Sensor: Detects the vehicle's presence and according to that traffic signals will be controlled

### 3.3. Inductive Loop Detector(ILD) Sensor:

It is a tuned electrical circuit with a long wire coiled to form the loop, installed into or under the surface of the road. Whenever a conductive object passes over it or stops within the loop, a magnetic field generated by the alternating electrical current within the sensor induces a weak electrical current in the conductive object. According to Lenz's law, the electrical current induced in the metal surface of the conductive object generates its magnetic field that opposes the magnetic field generated by the sensor coil, which results in the decrease of inductance. It also leads to the change in the resonant frequency of the sensor circuit and sends a pulse to the control unit indicating the presence of a vehicle<sup>[4]</sup>.

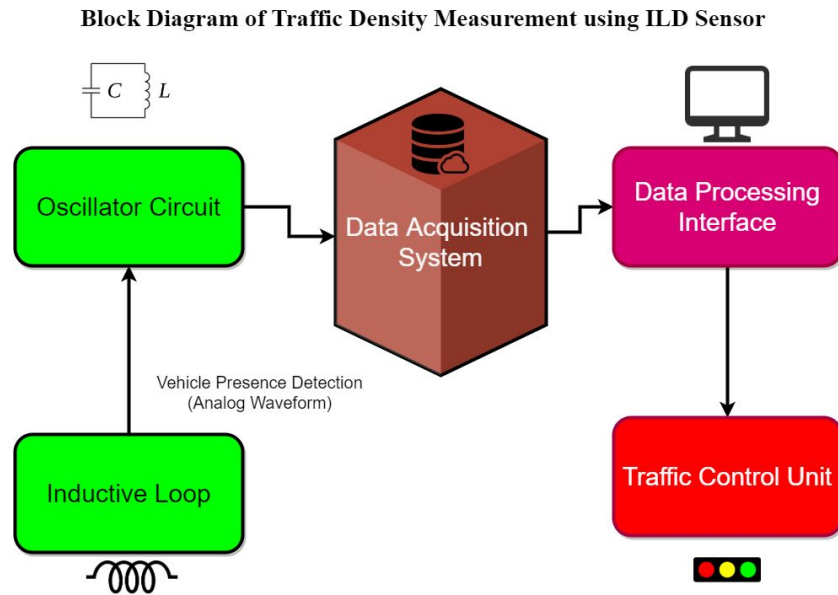

**Fig. 4:** Block Diagram of Traffic Density Measurement using ILD Sensor: Decreases inductance that leads to the change in resonant frequency and it sends the pulse to the Traffic Control Unit to indicate the vehicle's presence.

### 3.4. Piezoelectric/Pressure Sensor Approach:

These sensors are usually embedded in the road surfaces. In this methodology, the objective is to find an indirect mapping between the weight in motion applied by a traffic vehicle to the effective traffic area (satellite top view) covered by the same vehicle. Mathematically,

$$A = f(m)$$

where,

$A$  = Effective Traffic Area contribution of the vehicle, &  
 $m$  =mass of the vehicle.

These observations can be readily obtained by experiments over vehicles whose actual top surface area is known and then the empirical function  $f$  can be obtained using interpolation or regression techniques over the recorded data.

Whenever a vehicle passes over the installed road surface, a voltage impulse is detected by the sensor. This can be approximated as the impulse(Dirac Delta) signal whose magnitude is directly proportional to the weight of the vehicle. The accumulation of such signals can be done using Adder circuits which in turn help us calculate the Traffic Density.

In each cycle of a traffic light changing, the transducer measures the weights of several vehicles passing over it as an electrical impulse. It then approximates the vehicle top area ( $A$ ) using the functional mapping from the mass(impulse created) and then calculates the Internal Traffic Density of the node segment  $m$  as,

$$I_m(c) = \sigma\left(\sum_{k=1}^c f(w_k)\right)$$

where,

$c$  is the total cycle time,

$w$  is the instantaneous weight of the vehicle passing (voltage impulse signal),

$I_m(c)$  denote the Internal Traffic Density of the road segment  $m$  under the cycle  $c$ , &

$\sigma$  is the sigmoid function to squeeze the output to  $[0,1]$ .

## Traffic Detection & Control using Pressure/Piezoelectric Sensor

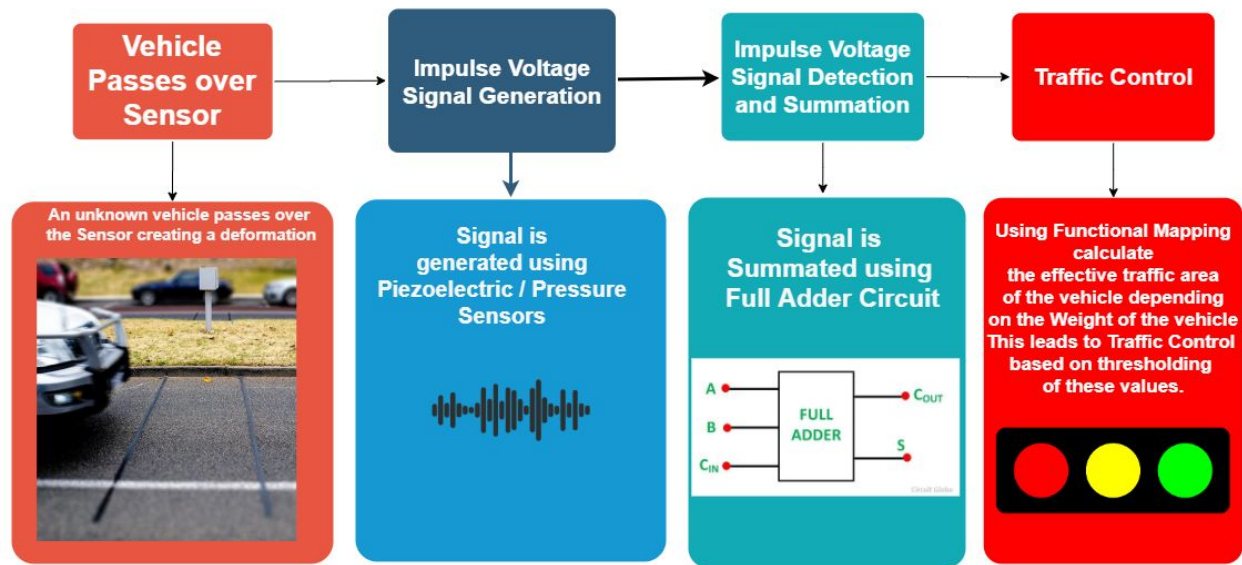

**Fig. 5:** Traffic Detection & Control using Pressure/Piezoelectric Sensor<sup>[6]</sup>: The mass (pressure) exerted by the vehicle on the sensor generates an impulse signal proportional to the distortion caused. This series of signals are sent to an Adder circuit which in turn can be used to calculate the Traffic Area of the vehicle.

Piezoelectric sensors collect data by converting mechanical energy to electrical energy. It's mounted in a groove cut into the road's surface. Whenever a vehicle passes over it, it squeezes and a voltage signal is generated due to an electric potential. When the car moves off, the voltage reverses. This change in voltage is used to detect and count the vehicles. The counting device that is attached to the sensor is placed by the side of the road in an enclosure. The data is collected via an Ethernet or RS232 connection to a laptop, or transmitted by modem.

There are also many more sensors like magnetic sensors, RADAR(Radio Detection And Ranging) sensors, RFID(Radio-Frequency Identification) sensors which are also used for density based traffic measurement.

### 3.5. Limitations of Sensor Technologies:

1. Traffic information provided by the sensors is limited.
2. These sensors fail in different climatic conditions.

#### 4. Image Processing Control:

This is the most efficient approach for traffic detection on a road. It eliminates the need for extra hardware and sensors<sup>[7]</sup>. In this methodology, a camera is placed on a long pillar where the road view can be taken clearly. The camera is used to capture the real-time traffic images at any instant on that road. Then this captured image is processed using Mask R-CNN<sup>[8]</sup>. Mask R-CNN<sup>[9]</sup> is the state-of-the-art image segmentation technology to detect and distinguish multiple objects in a single image. Mask R-CNN performs “instance segmentation”<sup>[8]</sup> on the images, which means different instances of the same type of object in the input image, are assigned distinct labels. By using this Mask R-CNN Image Segmentation Model, based on the retrieved predictions, we can detect a vehicle’s presence on a road.<sup>[10]</sup>



**Fig.6:** Real time traffic image captured by camera<sup>[11]</sup>



**Fig.7:** Visualization of vehicle’s detection results using Mask R-CNN Image Segmentation Model

##### 4.1. Limitations of Image Processing Control:

1. This method has an expensive installation.
2. It requires high processing power for real-time object detection.
3. Often cloud processors may have network issues.

#### 5. Conclusion:

This research proposes some ideas and methodologies based on the accurate estimation of the traffic congestion for a road segment. Each proposal is equipped with its own limitations and benefits. The IR & Ultrasonic sensor approaches, although being cheap, only return the vehicle count, irrespective of the effective traffic area covered by the different vehicle types. Piezoelectric, Pressure, & ILD sensors provide more insightful internal traffic density measurements due to their ability to indirectly map their output signals traffic jam contribution for each automobile separately. Digital Image Processing Techniques sustain detailed analytics on the traffic data and are ideal in solving traffic control optimization at a high-cost bargain.

As a result of the works carried out, based on the analysis of those approaches, it can be considered that all these methods are of practical interest and all of them can be used in Intelligent Transportation Systems (ITS). The methodologies we have simulated here, calculate the real-time traffic density. As per the requirements, the proposed approaches can also be combined to control traffic more effectively. The need for efficient traffic control mechanisms continues to rise under mismanaged roads, and hence the applications of the proposed methodologies are essential for effectively distributing time slots dependent on the traffic gridlock on certain cross-linking road segments.

All the source code used in this project is open-sourced and available for further research and application at [github.com/khanfarhan10/TrafficControl](https://github.com/khanfarhan10/TrafficControl).

## References:

- [1] Adam Van Etten, Broad Area Satellite Imagery Semantic Segmentation (BASISS), Medium, Sample Image from Las Vegas. [medium.com/the-downling/broad-area-satellite-imagery-semantic-segmentation-basiss-4a7ea2c8466f](https://medium.com/the-downling/broad-area-satellite-imagery-semantic-segmentation-basiss-4a7ea2c8466f).
- [2] Chari, Tenepalli Kalyan Sai Manikanta & Tutika, SaiTeja (2019). Density Based Traffic Control Signaling Using IR sensors. IJEAIS 3 (3):51-60. [philarchive.org/archive/CHADBT-3v1](http://philarchive.org/archive/CHADBT-3v1).
- [3] Guerrero-Ibañez, Juan & Zeadally, Sherali & Contreras Castillo, Juan. (2018). Sensor Technologies for Intelligent Transportation Systems. Sensors. 18. 1212. [doi.org/10.3390/s18041212](https://doi.org/10.3390/s18041212).
- [4] Bhaskar, Lala & Sahai, Ananya & Sinha, Deepti & Varshney, Garima & Jain, Tripti. (2015). Intelligent traffic light controller using inductive loops for vehicle detection. 518-522. [doi.org/10.1109/NGCT.2015.7375173](https://doi.org/10.1109/NGCT.2015.7375173).
- [5] Mehran Safdar, A Mobile Vehicle Weight Sensor and its Applications in Transportation; Accessed on 1<sup>st</sup> International Electronic Conference on Remote Sensing; Published: 6 June 2015. [doi.org/10.3390/ecrs-1-d015](https://doi.org/10.3390/ecrs-1-d015).
- [6] Windmill Software Ltd, Piezoelectric Sensor, Vehicle Sensing: Ten Technologies to Measure Traffic, Image Source: [windmill.co.uk/vehicle-sensing.html](http://windmill.co.uk/vehicle-sensing.html).
- [7] U. E. Prakash, K. T. Vishnupriya, A. Thankappan and A. A. Balakrishnan, "Density Based Traffic Control System Using Image Processing," 2018 International Conference on Emerging Trends and Innovations In Engineering And Technological Research (ICETIETR), Ernakulam, 2018, pp. 1-4, [doi.org/10.1109/ICETIETR.2018.8529111](https://doi.org/10.1109/ICETIETR.2018.8529111).
- [8] Mask R-CNN for Object Detection and Segmentation, heng2j, Github Source: [github.com/heng2j/Mask\\_RCNN](https://github.com/heng2j/Mask_RCNN).
- [9] K. He, G. Gkioxari, P. Dollár and R. Girshick, "Mask R-CNN," 2017 IEEE International Conference on Computer Vision (ICCV), Venice, 2017, pp. 2980-2988, [doi.org/10.1109/ICCV.2017.322](https://doi.org/10.1109/ICCV.2017.322).
- [10] Z. Al-Ariny, M. A. Abdelwahab, M. Fakhry and E. Hasaneen, "An Efficient Vehicle Counting Method Using Mask R-CNN," 2020 International Conference on Innovative Trends in Communication and Computer Engineering (ITCE), Aswan, Egypt, 2020, pp. 232-237, [doi.org/10.1109/ITCE48509.2020.9047800](https://doi.org/10.1109/ITCE48509.2020.9047800).
- [11] Berkeley, Canada, Interstate 80, Freeway with many lanes and heavy traffic. Image Source: Traffic, Wikipedia. [en.wikipedia.org/wiki/Traffic](https://en.wikipedia.org/wiki/Traffic).